

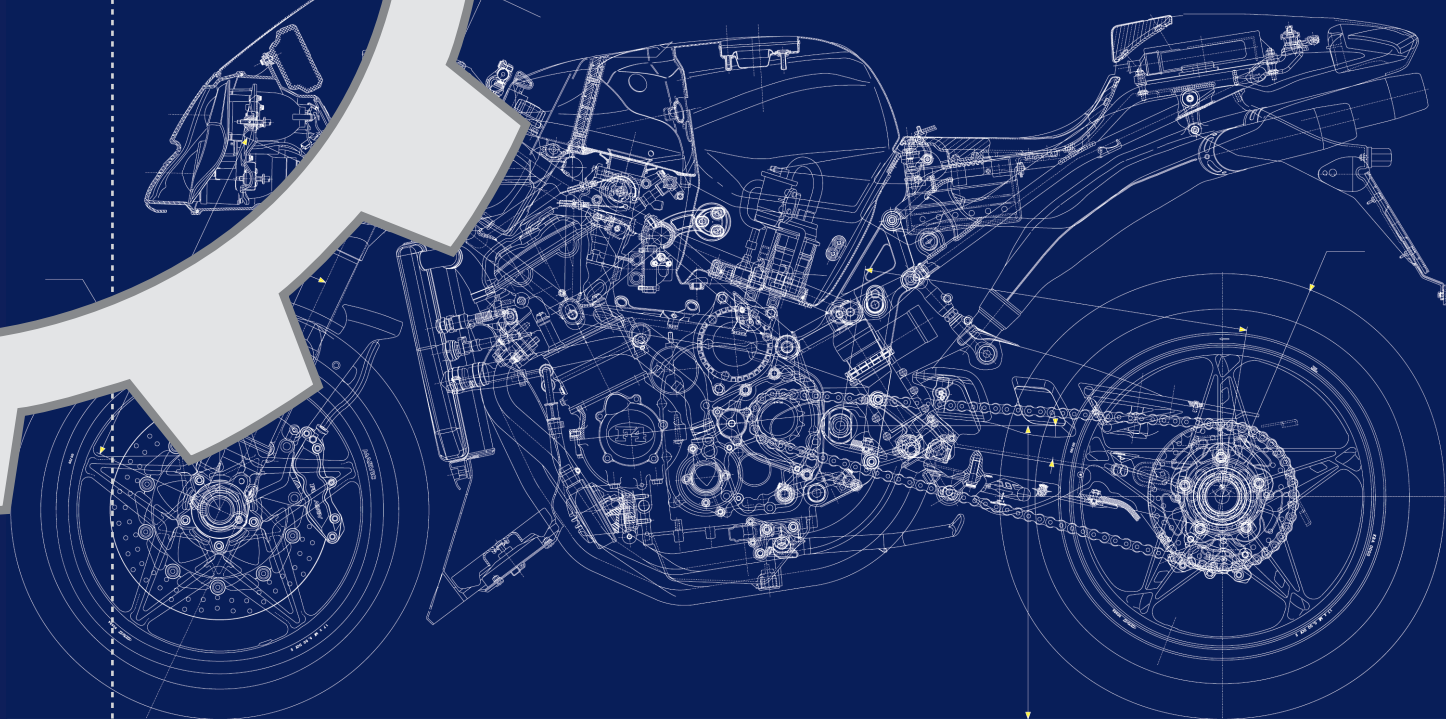

Motorcycle Art

F4



MV AGUSTA F4 750 S - S 1+1 - SPR - SR - SR 1+1 - SENNA

Catalogo ricambi

Spare parts catalogue

Catalogue des pièces détachées

Ersatzteilkatalog

Catálogo de recambios

© 2010

È vietata la riproduzione anche parziale di questo documento senza il consenso scritto della MV Agusta S.p.A.

Part. n° 800098957 - Edizione n° 5

Stampato nel Settembre 2010



SCOPO DEL CATALOGO

Questo catalogo è stato realizzato per la sola ordinazione delle parti di ricambio.

Per ottenere qualsiasi altra informazione è necessario consultare il manuale d'officina o contattare direttamente il costruttore.

PURPOSE OF THE CATALOGUE

This catalogue has been designed for spare parts ordering only.

To obtain any other information you should check the servicing manual or contact the manufacturer directly.

ZWECK DES KATALOGS

Dieser Katalog dient ausschliesslich der Bestellung von Ersatzteilen.

Für alle weiteren Informationen im technischen Handbuch nachschlagen oder direkt den Hersteller kontaktieren.

VALIDITÀ DEL CATALOGO

Le informazioni contenute in questo catalogo si riferiscono unicamente ai motocicli con numero di matricola telaio uguale o superiore a: **(ZCGF401BA2V) 004146 ; U.S.A.: (ZCGAGFLJ92V) 100292 -monoposto- o 200059 -biposto-**.

EFFECTIVENESS OF THE CATALOGUE

The information contained in this catalogue only refers to motorcycles with a frame serial number equal or upper than **(ZCGF401BA2V) 004146; U.S.A.: (ZCGAGFLJ92V) 100292 -single seater- or 200059 -two-seater-**.

GÜLTIGKEIT DES KATALOGS

Die Informationen in dieser Katalog enthalten gelten nur für die Motorrad mit ein Rahmennummer gleich oder mehr als **(ZCGF401BA2V) 004146; U.S.A.: (ZCGAGFLJ92V) 100292 -einsitzer- oder 200059 -zweisitzer-**.

STRUTTURA DEL CATALOGO

Nell'illustrazione sono riportate alcune informazioni per interpretare il contenuto del catalogo.

CATALOGUE STRUCTURE

The picture contains some instructions on how to use the catalogue.

AUFBAU DES KATALOGS

In der Erläuterung sind einige Informationen für die richtige Interpretation des Kataloginhalts angeführt.

BUT DE CATALOGUE

Ce catalogue a été exclusivement réalisé pour commander des pièces détachées. Pour avoir toute autre information, consulter le manuel d'entretien ou bien prendre contact directement avec le constructeur.

FINALIDAD DEL CATÁLOGO

Este catálogo se ha realizado sólo para el pedido de las piezas de recambio. Para cualquier otra información es necesario consultar el manual de taller o ponerse en contacto directo con el fabricante.

VALIDITÉ DE CATALOGUE

Les informations contenu en ce catalogue se réfèrent uniquement à les motos avec un numéro de matricule du cadre égal ou supérieur à **(ZCGF401BA2V) 004146; U.S.A.: (ZCGAGFLJ92V) 100292 -monoplace- ou 200059 -biplace-**.

VALIDEZ DEL CATÁLOGO

La información en el interior de este manual corresponde solo a las motocicletas con un número de matrícula bastidor a partir de **(ZCGF401BA2V) 004146; U.S.A.: (ZCGAGFLJ92V) 100292 -monoplaza- o 200059 -biplaza-**.

Numeri di riferimento, codice e quantità.

Reference numbers, code and quantity.
numéros de référence, code et quantité.
Bezugsnummern, Code und Menge.
Números de referencia, código y cantidad.

Specifiche (es: area di commercializzazione, caratteristiche costruttive, colori, note, ecc.)

Specifications (e.g. marketing area, construction characteristics, colours, notes etc.).
Specifications (par ex. zone de commercialisation, caractéristiques de construction, couleurs, notes etc.).
Spezifische Angaben (z.B. Handelsgebiet, Herstellungseigenschaften, Farben, Hinweise, usw.).
Especificaciones (ej: área de comercialización, características de fabricación, colores, notas, etc.).

Validità con riferimento matricola telaio e matricola motore.

Validity referred to frame serial number and engine serial number.
Validité concernant le matricule du châssis et le matricule du moteur.
Gültigkeit mit Bezug auf die Rahmen- und Motornummer.
Validez referida a la matrícula bastidor y matrícula motor.

750 S	750 S 1+1	SPR	SR-SR1+1	SENNÄ	► I FRAME ►	► I ENGINE ►
1	1					
2						
3						
4						
5	1	800084882	1	EV02 / EV03		
6	1	80B084882	1	Euro 2		
7	1	800084882	1			
8	1	80A084882	1			
9	2	800089745	2			
10						
11						
12						
13						
14						
15						
16						
17						
18						
19						
20	20	800090431	1			
21	21	800090432	1			
22	22	800098706	1			
23	22	800098707	1			
24	23	8F0090426	3			
25	24	800097885	2			
26	24	800089305	2			

Modelli motocicletta.
Motorcycle models.
Modèles de moto.
Motorradmodelle.
Modelos motocicleta.

Numero di tavola e di edizione.

Plate and edition number.
Numéro de planche et d'édition.
Tafelnummer und Nummer der Ausgabe.
Número de tabla y de edición.

Note a piè di pagina.

Footnotes.
Notes au bas de la page.
Fussnoten.
Notas al pie de la página.

Numero di tabella e di edizione.

Table and edition number.
Numéro de tableau et d'édition.
Tabellennummer und Nummer der Ausgabe.
Número de ilustración y de edición.



INTRODUZIONE AL CATALOGO RICAMBI

INTRODUCTION TO THE SPARE PARTS CATALOGUE • INTRODUCTION AU CATALOGUE DES PIÈCES DÉTACHÉES
EINFÜHRUNG IN DEN ERSATZTEILKATALOG • INTRODUCCIÓN AL CATÁLOGO DE RECAMBIOS

SIMBOLI E ABBREVIAZIONI

- ▶ I Validità fino alla matricola
- ▶ I Validità dalla matricola

SYMBOLS AND ABBREVIATIONS

- ▶ I Validity up to serial number
- ▶ I Validity from serial number

- F USA** ...Valid for (France, Usa ...) version only
- 1 2** ...Footnotes
- A B** ...Colour code
- ≠ Thickness

SYMBOLS UND ABKÜRZUNGEN

- ▶ I Gültig ab der Kennnummer
- ▶ I Gültig bis zur Kennnummer

- F USA** ...Gilt nur die Ausführung für Frankreich, die USA...
- 1 2** ...Fussnoten
- A B** ...Farbcode
- ≠ Stärke

- F USA** ...Valido solo per versione Francia, Usa, ...
- 1 2** ...Note a piè pagina

SYMBOLS ET ABRÉVIATIONS

- ▶ I Validité jusqu'au matricule
- ▶ I Validité à partir du matricule

- F USA** ...Valable uniquement pour la variante France, Usa, etc.
- 1 2** ...Notes au bas de la page
- A B** ...Code couleur
- ≠ Épaisseur

SÍMBOLOS Y ABBREVIACIONES

- ▶ I Validez hasta la matrícula
- ▶ I Validez a partir de la matrícula

- F USA** ...Válido sólo para los modelos Francia, Usa, ...
- 1 2** ...Notas al pie de la página
- A B** ...Código color
- ≠ Grosor

- A B** ...Codice colore
- ≠ Spessore

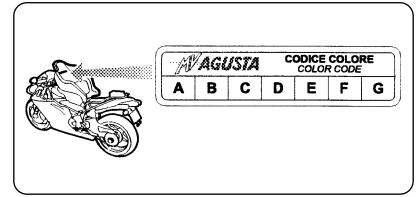

Le misure sono espresse in mm.
Measures are expressed in mm.
Les mesures sont exprimées en mm.
Die Masse sind in mm angegeben.
Las medidas están expresadas en mm.

- **Codici colore F4 750 S - S 1+1:**
 - A** Versione Rosso/Argento - Red/Silver version - Version Rouge/Argent - Rot/Silber Version - Versión Rojo/Plata.
 - B** Versione Argento - Silver version - Version Argent - Silber Version - Versión Plata.
 - C** Versione Nera - Black version - Version Noire - Schwarze Version - Versión Negra.

COME CONSULTARE IL CATALOGO RICAMBI

- 1) Identificare la parte di interesse e relativo numero di tavola.
- 2) Rintracciare la tavola all'interno del catalogo.
- 3) Identificare la parte ed il relativo numero di riferimento all'interno della tavola esplosa.

- 4) Identificare il numero di codice della parte in base al numero di riferimento e al modello di motocicletta.
- 5) Controllare la presenza di note e validità.

HOW TO CHECK THE SPARE PARTS CATALOGUE

- 1) Locate your part of interest and the relevant plate number.
- 2) Find the plate in the catalogue.
- 3) Locate the part and the corresponding reference number within the exploded view plate.
- 4) Locate the part code number according to the reference number and the motorcycle model.
- 5) Check any footnotes and validity information.

COMMENT CONSULTER LE CATALOGUE DES PIÈCES DÉTACHÉES

- 1) Identifier la pièce qui vous intéresse et le numéro de planche correspondant.
- 2) Repérer la planche à l'intérieur du catalogue.
- 3) Identifier la pièce et le numéro de référence correspondant à l'intérieur de la planche éclatée.
- 4) Identifier le code de la pièce sur la base du numéro de référence et du modèle de moto.
- 5) Contrôler la présence de notes et la validité.

NACHSCHLAGEN IM ERSATZTEILKATALOG

- 1) Das gewünschte Ersatzteil und die entsprechende Tafel feststellen.
- 2) Die Tafel im Katalog suchen.
- 3) Das Teil und die dazugehörige Bezugsnummer auf der Explosions-tafel suchen.
- 4) Aufgrund der Bezugsnummer und des Motorradmodells den Code des Ersatzteils bestimmen.
- 5) Kontrollieren, ob Hinweise oder Angaben zur Gültigkeit angeführt sind.

COMO CONSULTAR EL CATALOGO DE RECAMBIOS

- 1) Identificar la parte que interesa y el correspondiente número de tabla.
- 2) Buscar la tabla en el interior del catálogo.
- 3) Identificar la pieza y el correspondiente número de referencia en el interior de la tabla de despiece.
- 4) Identificar el número de código de la pieza en función del número de referencia y del modelo de la motocicleta.
- 5) Controlar si hay notas y la validez.

ASSEMBLY AMMORTIZZATORE DI TERZO
STEERING DAMPER ASSEMBLY - ENSEMBLE AMORTISSEUR DE LA DIRECTION

N.	Code	Qty.	Note	750 S	750 S 1+1	SA	FRAME	ENGINE
1	80008406	1						
2	800082769	1						
3	80008408	1						
4	80008303	2						
5	800082778	4						

Indice figurativo.
Figurative index.
Index figuratif.
Bildverzeichnis.
Índice de figuras.

INTRODUZIONE AL CATALOGO RICAMBI

INTRODUCTION TO THE SPARE PARTS CATALOGUE • INTRODUCTION AU CATALOGUE DES PIÈCES DÉTACHÉES
EINFÜHRUNG IN DEN ERSATZTEILKATALOG • INTRODUCCIÓN AL CATÁLOGO DE RECAMBIOS



COME ORDINARE LE PARTI DI RICAMBIO

Nel modulo di ordinazione riportare:

- 1 Il numero di codice della parte
- 2 La quantità richiesta
- 3 Il modello di motocicletta
- 4 Il numero di telaio e motore

HOW TO ORDER SPARE PARTS

In the order form quote:

- 1 The part code number
- 2 Your required amount
- 3 The motorcycle model
- 4 Frame and engine number

BESTELLUNG VON ERSATZTEILEN

In das Bestellformular sind einzutragen:

- 1 Der Code des Ersatzteils
- 2 Die gewünschte Anzahl
- 3 Das Motorradmodell
- 4 Fahrgestell- und Motornummer

COMMENT COMMANDER LES PIÈCES DÉTACHÉES

Dans le formulaire de commande spécifier:

- 1 Le numéro de code de la pièce
- 2 La quantité voulue
- 3 Le modèle de moto
- 4 Le numéro du cadre et du moteur

COMO PEDIR LAS PIEZAS DE RECAMBIO

Indicar en el impreso de pedido:

- 1 El número de código de la pieza
- 2 La cantidad solicitada
- 3 El modelo de motocicleta
- 4 El número de bastidor y motor

FAC SIMILE SCHEDA DI ORDINAZIONE
ORDER FORM FACSIMILE
FAC-SIMILE DE LA FICHE DE COMMANDE
FAKSIMILE DES BESTELLBLÄTTES
FAC SIMIL FICHA DE PEDIDO

MV AGUSTA Motor S.p.A.

Data Date - Date Datum - Fecha	Mittente Sender - Envoyeur Absender - Remitente	Cod. concessionario Dealer code - Code du concessionnaire Kennnummer des Vertragsabnehmers - Cod. concessionario
Stock Stock - Stock Lagerbestand - Stock <input type="checkbox"/>	Urgente Urgent - Urgent Dringend - Urgente <input type="checkbox"/>	Modalità di spedizione Shipping information - Mode d'expédition Versandbestimmungen - Modalidad de envío
Modello Model - Modèle Modèle - Modelo	Telaio Frame - Châssis Rahmen - Bastidor	Motore Engine - Moteur Motor - Motor
Codice Code - Code Code - Código	Qty.	Codice Code - Code Code - Código
Modello Model - Modèle Modèle - Modelo	Telaio Frame - Châssis Rahmen - Bastidor	Motore Engine - Moteur Motor - Motor
Codice Code - Code Code - Código	Qty.	Codice Code - Code Code - Código

N.	Code	Qty	Note	750 S	750 S 1+1	SPR	SR-SR 1+1	SENNÀ	► I FRAME I ►	► I ENGINE I ►
1	800086406	1		•	•	•	•	•		
2	800082769	1		•	•	•	•	•		

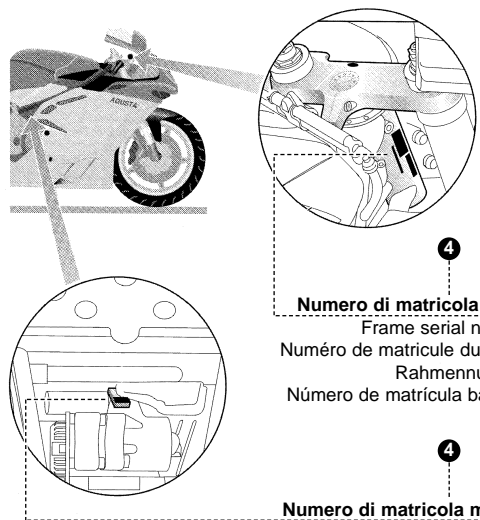
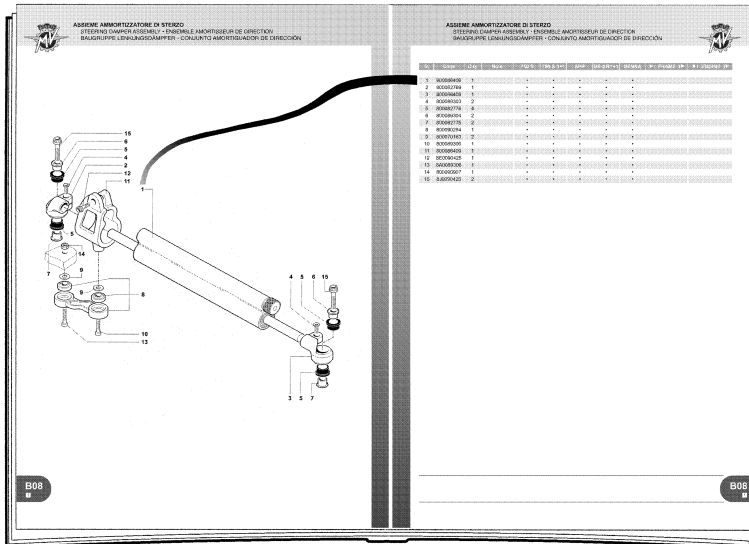

Numero di matricola telaio.
Frame serial number.
Numéro de matricule du cadre.
Rahmennummer.
Número de matrícula bastidor.

Numero di matricola motore.
Engine serial number.
Numéro de série moteur.
Motornummer.
Número de matrícula motor.



INDICE DESCRITTIVO

DESCRIPTIVE INDEX • INDEX DESCRIPTIF
BESCHREIBENDES INHALTSVERZEICHNIS • ÍNDICE DESCRIPTIVO

A01
4

ASSIEME TELAIO

FRAME ASSEMBLY • ENSEMBLE CADRE
BAUGRUPPE RAHMEN • CONJUNTO BASTIDOR

A02
3

ASSIEME TELAIO POSTERIORE (MONOPOSTO)

REAR FRAME ASSEMBLY (SINGLE-SEATER) • ENSEMBLE CADRE ARRIÈRE (MONOPLACE)
BAUGRUPPE HINTERER RAHMEN (EINSITZER) • CONJUNTO BASTIDOR TRASERO (MONOPLAZA)

A03
3

ASSIEME TELAIO POSTERIORE (BIPOSTO)

REAR FRAME ASSEMBLY (TWO-SEATER) • ENSEMBLE CADRE ARRIÈRE (BIPLACE)
BAUGRUPPE HINTERER RAHMEN (ZWEISITZER) • CONJUNTO BASTIDOR TRASERO (BIPLAZA)

B01
4

ASSIEME FORCELLONE

SWINGING ARM ASSEMBLY • ENSEMBLE FOURCHE
BAUGRUPPE GABEL • CONJUNTO HORQUILLA

B02
3

ASSIEME SOSPENSIONE POSTERIORE

REAR SUSPENSION ASSEMBLY • ENSEMBLE SUSPENSION ARRIÈRE
BAUGRUPPE HINTERRADAUFHÄNGUNG • CONJUNTO SUSPENSIÓN TRASERA

B03
2

ASSIEME SOSPENSIONE ANTERIORE

FRONT SUSPENSION ASSEMBLY • ENSEMBLE SUSPENSION AVANT
BAUGRUPPE VORDERRADAUFHÄNGUNG • CONJUNTO SUSPENSIÓN DELANTERA

B04
2

FORCELLA DESTRA (F4 S / S 1+1 / SR / SENNA)

RIGHT-HAND FORK (F4 S / S 1+1 / SR / SENNA) • FOURCHE DROITE (F4 S / S 1+1 / SR / SENNA)
RECHTE GABEL (F4 S / S 1+1 / SR / SENNA) • HORQUILLA DERECHA (F4 S / S 1+1 / SR / SENNA)

B05
2

FORCELLA SINISTRA (F4 S / S 1+1 / SR / SENNA)

LEFT-HAND FORK (F4 S / S 1+1 / SR / SENNA) • FOURCHE GAUCHE (F4 S / S 1+1 / SR / SENNA)
LINKE GABEL (F4 S / S 1+1 / SR / SENNA) • HORQUILLA IZQUIERDA (F4 S / S 1+1 / SR / SENNA)

B06
2

FORCELLA DESTRA (F4 SPR / SENNA)

RIGHT-HAND FORK (F4 SPR / SENNA) • FOURCHE DROITE (F4 SPR / SENNA)
RECHTE GABEL (F4 SPR / SENNA) • HORQUILLA DERECHA (F4 SPR / SENNA)

B07
1

FORCELLA SINISTRA (F4 SPR / SENNA)

LEFT-HAND FORK (F4 SPR / SENNA) • FOURCHE GAUCHE (F4 SPR / SENNA)
LINKE GABEL (F4 SPR / SENNA) • HORQUILLA IZQUIERDA (F4 SPR / SENNA)

B08
1

ASSIEME AMMORTIZZATORE DI STERZO

STEERING DAMPER ASSEMBLY • ENSEMBLE AMORTISSEUR DE DIRECTION
BAUGRUPPE LENKUNGSDÄMPFER • CONJUNTO AMORTIGUADOR DE DIRECCIÓN

C01
4

ASSIEME RUOTA POSTERIORE

REAR WHEEL ASSEMBLY • ENSEMBLE ROUE ARRIÈRE
BAUGRUPPE HINTERRAD • CONJUNTO RUEDA TRASERA

C02
3

ASSIEME RUOTA ANTERIORE

FRONT WHEEL ASSEMBLY • ENSEMBLE ROUE AVANT
BAUGRUPPE VORDERRAD • CONJUNTO RUEDA DELANTERA

D01
4

ASSIEME PEDANA SINISTRA

LEFT-HAND FOOTREST ASSEMBLY • ENSEMBLE REPOSE-PIEDS GAUCHE
BAUGRUPPE LINKES FUSSBRETT • CONJUNTO ESTRIBO IZQUIERDO

D02
4

ASSIEME PEDANA DESTRA

RIGHT-HAND FOOTREST ASSEMBLY • ENSEMBLE REPOSE-PIEDS DROIT
BAUGRUPPE RECHTES FUSSBRETT • CONJUNTO ESTRIBO DERECHO

**D03**
2**ASSIEME SEMIMANUBRIO DESTRO**RIGHT-HAND HANDLEBAR ASSEMBLY • ENSEMBLE GUIDON DROIT
BAUGRUPPE RECHTE LENKERHÄLFTE • CONJUNTO SEMIMANILLAR DERECHO**D04**
3**ASSIEME SEMIMANUBRIO SINISTRO**LEFT-HAND HANDLEBAR ASSEMBLY • ENSEMBLE GUIDON GAUCHE
BAUGRUPPE LINKE LENKERHÄLFTE • CONJUNTO SEMIMANILLAR IZQUIERDO**D05**
2**SERRATURE**LOCKS • VERROUILLAGES
SCHLÖSSER • CERRADURAS**E01**
5**ASSIEME CARENATURE**FAIRING ASSEMBLY • ENSEMBLE CARÉNAGE
BAUGRUPPE KAROSSERIE UND VERKLEIDUNG • CONJUNTO CARENADOS**E02**
4**ASSIEME AIRBOX**AIRBOX ASSEMBLY • ENSEMBLE AIRBOX
BAUGRUPPE AIRBOX • CONJUNTO AIRBOX**E03**
3**ASSIEME SERBATOIO BENZINA**FUEL TANK ASSEMBLY • ENSEMBLE RÉSERVOIR DE CARBURANT
BAUGRUPPE TANK • CONJUNTO DEPÓSITO GASOLINA**E04**
3**ASSIEME CODONE (MONOPOSTO)**REAR FAIRING ASSEMBLY (SINGLE-SEATER) • ENSEMBLE CARÉNAGE DE SELLE (MONOPLACE)
BAUGRUPPE HECK (EINSITZER) • CONJUNTO COLÍN (BIPLAZA)**E05**
3**ASSIEME CODONE (BIPOSTO)**REAR FAIRING ASSEMBLY (TWO-SEATER) • ENSEMBLE CARÉNAGE DE SELLE (BIPLACE)
BAUGRUPPE HECK (ZWEISITZER) • CONJUNTO COLÍN (BIPLAZA)**F01**
3**IMPIANTO ELETTRICO**ELECTRIC SYSTEM • INSTALLATION ÉLECTRIQUE
ELEKTRISCHE ANLAGE • INSTALACIÓN ELÉCTRICA**F02**
2**IMPIANTO ELETTRICO**ELECTRIC SYSTEM • INSTALLATION ÉLECTRIQUE
ELEKTRISCHE ANLAGE • INSTALACIÓN ELÉCTRICA**F03**
2**PROIETTORE ANTERIORE**FRONT HEADLIGHT • PROJECTEUR AVANT
SCHEINWERFER • PROYECTOR DELANTERO**F04**
3**IMPIANTO ELETTRICO**ELECTRIC SYSTEM • INSTALLATION ÉLECTRIQUE
ELEKTRISCHE ANLAGE • INSTALACIÓN ELÉCTRICA**F05**
2**IMPIANTO ELETTRICO**ELECTRIC SYSTEM • INSTALLATION ÉLECTRIQUE
ELEKTRISCHE ANLAGE • INSTALACIÓN**F06**
3**IMPIANTO ELETTRICO**ELECTRIC SYSTEM • INSTALLATION ÉLECTRIQUE
ELEKTRISCHE ANLAGE • INSTALACIÓN ELÉCTRICA**F07**
2**IMPIANTO ELETTRICO**ELECTRIC SYSTEM • INSTALLATION ÉLECTRIQUE
ELEKTRISCHE ANLAGE • INSTALACIÓN ELÉCTRICA



INDICE DESCRITTIVO

DESCRIPTIVE INDEX • INDEX DESCRIPTIF
BESCHREIBENDES INHALTSVERZEICHNIS • ÍNDICE DESCRIPTIVO

G01
3

ASSIEME CARTER MOTORE

CRANKCASE ASSEMBLY • ENSEMBLE CARTER DU MOTEUR
BAUGRUPPE MOTORGEHÄUSE • CONJUNTO CÁRTER MOTOR

G02
3

ASSIEME ALBERO MOTORE

CRANK SHAFT ASSEMBLY • ENSEMBLE VILEBREQUIN
BAUGRUPPE KURBELWELLE • CONJUNTO CIGÜEÑAL

G03
2

ASSIEME CILINDRI E PISTONE

CYLINDER AND PISTON ASSEMBLY • ENSEMBLE CYLINDRES ET PISTON
BAUGRUPPE ZYLINDER UND KOLBEN • CONJUNTO CILINDROS Y PISTONES

G04
3

ASSIEME TESTATA

CYLINDER HEAD ASSEMBLY • ENSEMBLE CULASSE
BAUGRUPPE ZYLINDERKOPF • CONJUNTO CULATA

G05
3

DISTRIBUZIONE

TIMING SYSTEM • DISTRIBUTION
VENTILSTEUERUNG • DISTRIBUCIÓN

G06
3

LUBRIFICAZIONE

LUBRICATION SYSTEM • GRAISSAGE
SCHMIERSYSTEM • LUBRIFICACIÓN

G07
2

POMPA ACQUA

WATER PUMP • POMPE À EAU
WASSERPUMPE • BOMBA AGUA

G08
2

IMPIANTO DI RAFFREDDAMENTO

COOLING SYSTEM • CIRCUIT DE REFROIDISSEMENT
KÜHLSYSTEM • INSTALACIÓN DE REFRIGERACIÓN

G09
3

ASSIEME FRIZIONE

CLUTCH ASSEMBLY • ENSEMBLE EMBRAYAGE
BAUGRUPPE KUPPLUNG • CONJUNTO EMBRAGUE

G10
2

ASSIEME CAMBIO (F4 S / S 1+1 EV 02 / EV 03)

CHANGE GEAR ASSEMBLY (F4 S / S 1+1 EV 02 / EV 03) • ENSEMBLE BOÎTE DE VITESSE (F4 S / S 1+1 EV 02 / EV 03)
BAUGRUPPE GETRIEBE (F4 S / S 1+1 EV 02 / EV 03) • CONJUNTO CAMBIO (F4 S / S 1+1 EV 02 / EV 03)

G11
3

SELETTORE CAMBIO

GEAR SELECTOR • SÉLECTEUR DE VITESSES
GANGSCHALTER • SELECTOR CAMBIO

G12
3

GRUPPO POMPA BENZINA

FUEL PUMP ASSEMBLY • GROUPE POMPE D'ALIMENTATION
BAUGRUPPE BENZINPUMPE • GRUPO BOMBA GASOLINA

G13
4

ALIMENTAZIONE MOTORE

FUEL SYSTEM • ALIMENTATION MOTEUR
MOTORVERSORGUNG • ALIMENTACIÓN MOTOR

G14
2

AVVIAMENTO

STARTING SYSTEM • DÉMARREUR
ANLASSERSYSTEM • PUESTA EN MARCHA

G15
2

IMPIANTO ELETTRICO MOTORE

ENGINE ELECTRIC SYSTEM • INSTALLATION ÉLECTRIQUE MOTEUR
ELEKTRISCHE ANLAGE MOTOR • INSTALACIÓN ELÉCTRICA MOTOR

INDICE DESCRITTIVO

DESCRIPTIVE INDEX • INDEX DESCRIPTIF
BESCHREIBENDES INHALTSVERZEICHNIS • ÍNDICE DESCRIPTIVO



G16
3

IMPIANTO DI SCARICO

EXHAUST SYSTEM • ÉCHAPPEMENT
ABGASANLAGE • INSTALACIÓN DE ESCAPE

G17
3

ASSIEME CAMBIO (F4 S / S 1+1 EV 03 - Euro 2 / SPR / SR / SENNA)

CHANGE GEAR ASSEMBLY (F4 S / S 1+1 EV 03 - Euro 2 / SPR / SR / SENNA) • ENSEMBLE BOÎTE DE VITESSE (F4 S / S 1+1 EV 03 - Euro 2 / SPR / SR / SENNA) • BAUGRUPPE GETRIEBE (F4 S / S 1+1 EV 03 - Euro 2 / SPR / SR / SENNA) • CONJUNTO CAMBIO (F4 S / S 1+1 EV 03 - Euro 2 / SPR / SR / SENNA)

H01
4

DOTAZIONI

OUTFIT • ÉQUIPEMENT
BORDWERKZEUG • EQUIPAMIENTO

J01
2

ATTREZZATURE DI SERVIZIO (CICLISTICA)

SERVICE TOOLS (FRAME) • MATÉRIEL (PARTIE CYCLE)
SPEZIALWERKZEUG (RAHMEN) • UTILLAJE DE SERVICIO (MOTOCICLETA)

J02
2

ATTREZZATURE DI SERVIZIO (CICLISTICA)

SERVICE TOOLS (FRAME) • MATÉRIEL (PARTIE CYCLE)
SPEZIALWERKZEUG (RAHMEN) • UTILLAJE DE SERVICIO (MOTOCICLETA)

J03
3

ATTREZZATURE DI SERVIZIO (MOTORE)

SERVICE TOOLS (ENGINE) • MATÉRIEL (MOTEUR)
SPEZIALWERKZEUG (MOTOR) • UTILLAJE DE SERVICIO (MOTOR)

K01
3

VARIANTI ESTERO

VERSIONS FOR FOREIGN COUNTRIES • VARIANTES ÉTRANGER
MODELLVARIANTEN AUSLAND • VARIANTES EXTRANJERO

K02
1

ASSIEME CANISTER (USA)

CARBON CANISTER ASSEMBLY (USA) • ENSEMBLE CANISTER (USA)
BAUGRUPPE CARBONKANISTER (USA) • CONJUNTO CANISTER (USA)

Z01
5

INDICE CODICI / DENOMINAZIONI

CODEX / DESIGNATION INDEX • INDEX CODES / DÉNOMINATIONS
INHALTSVERZEICHNIS CODE • ÍNDICE CÓDIGOS / DENOMINACIONES



INDICE FIGURATIVO
 FIGURATIVE INDEX • INDEX FIGURATIF
 BILDVERZEICHNIS • ÍNDICE DE FIGURAS

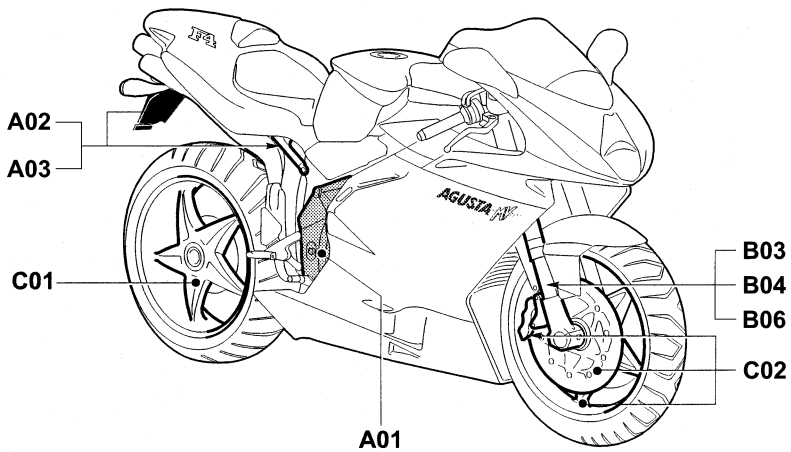
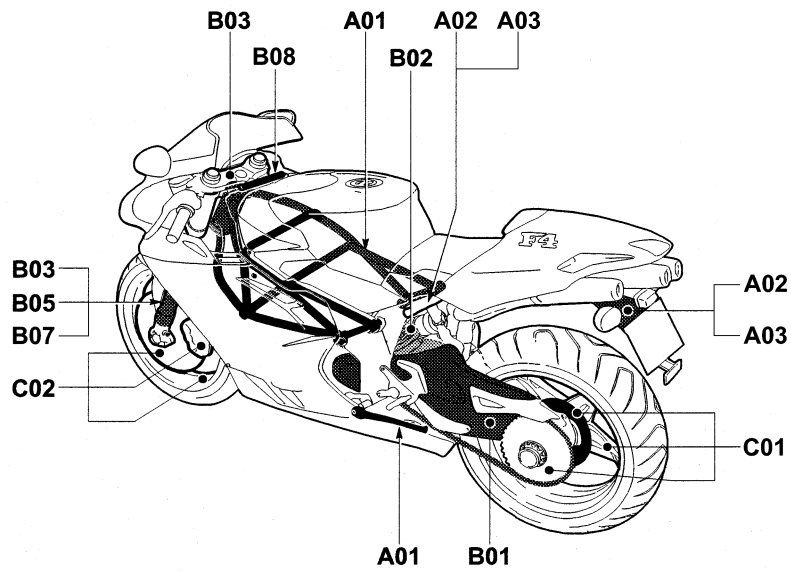
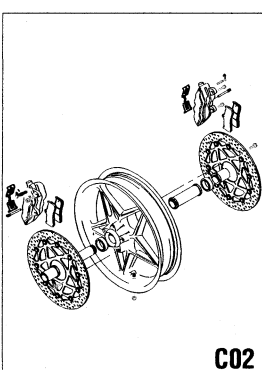
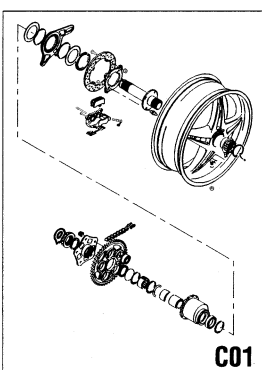
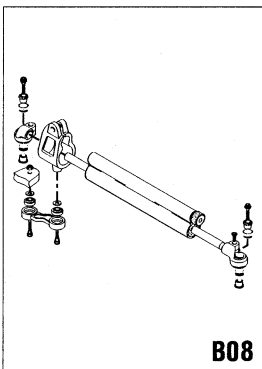
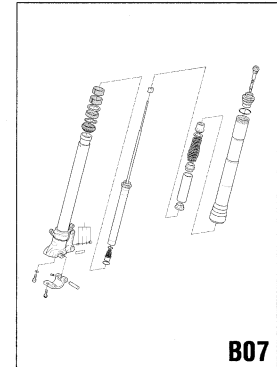
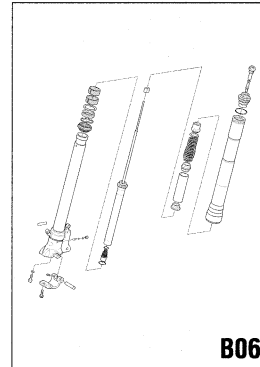
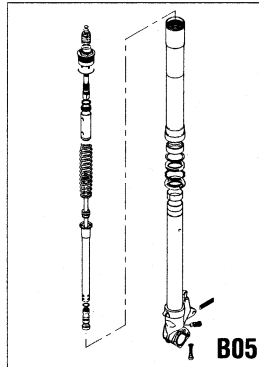
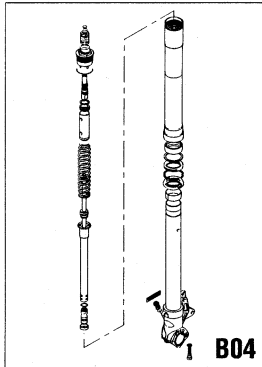
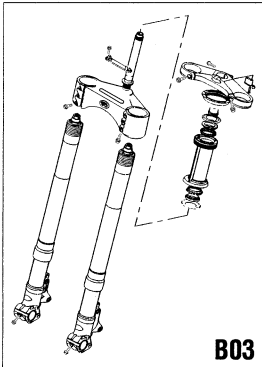
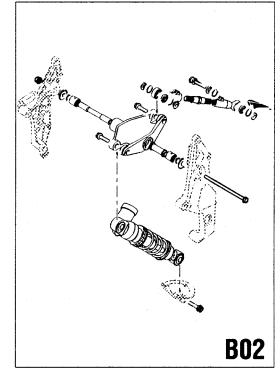
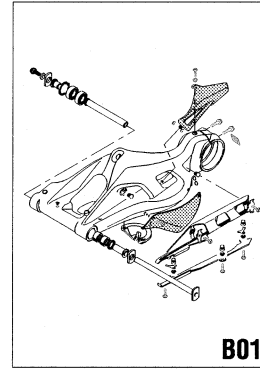
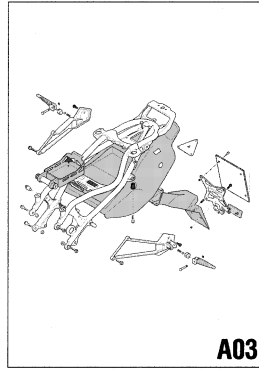
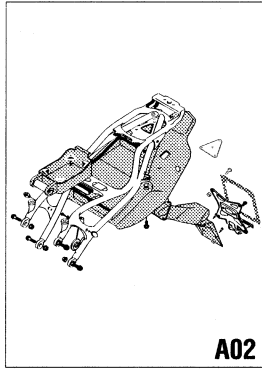
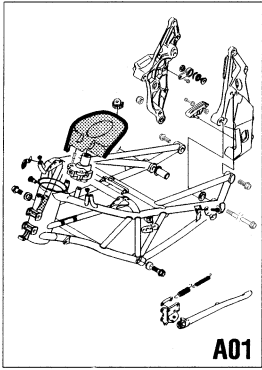

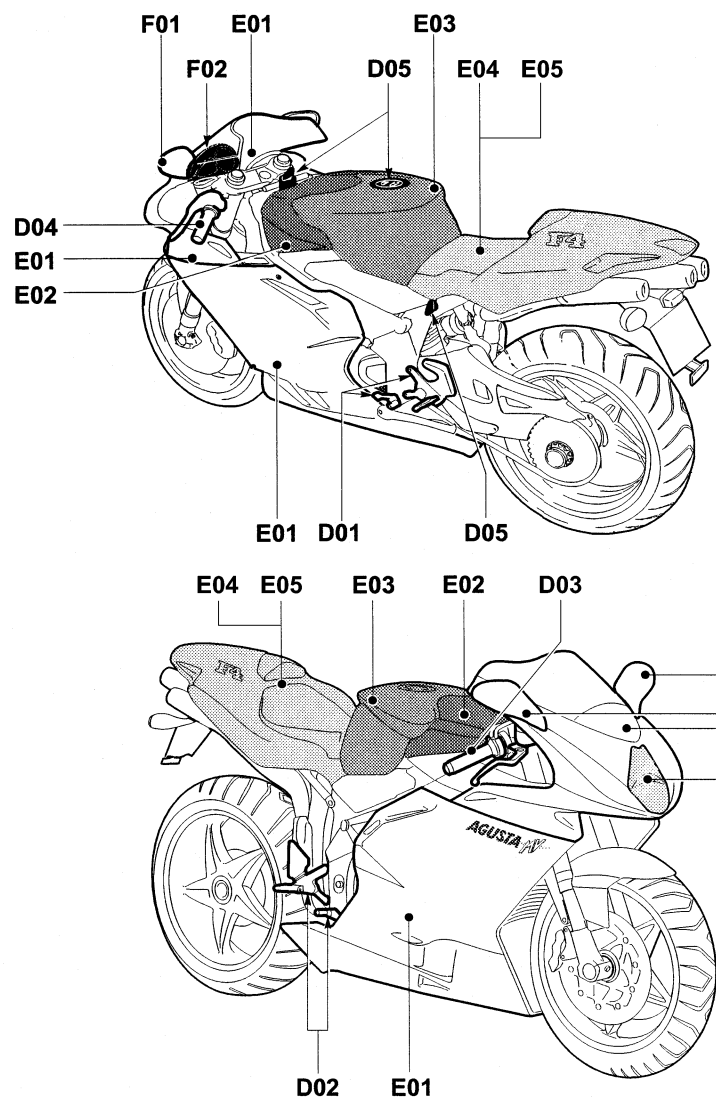
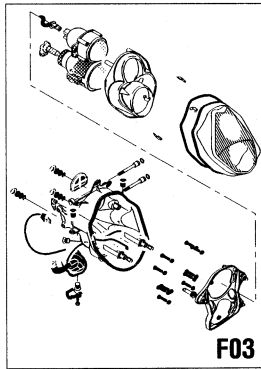
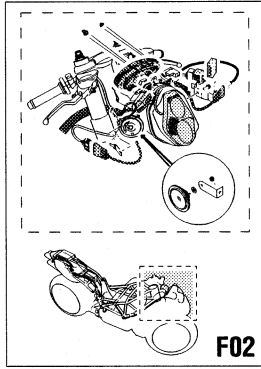
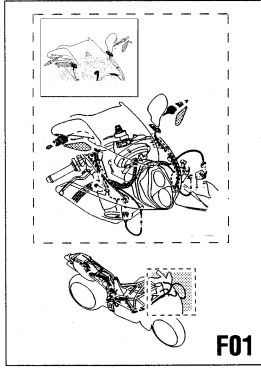
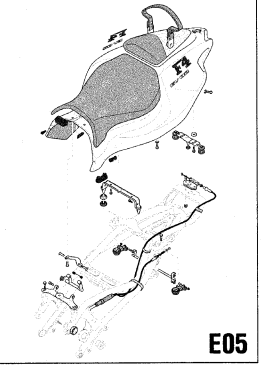
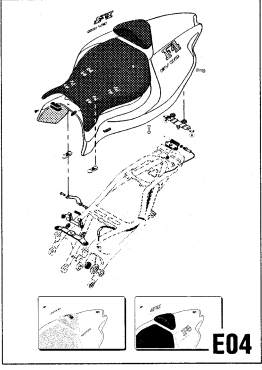
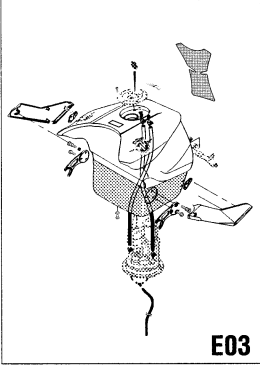
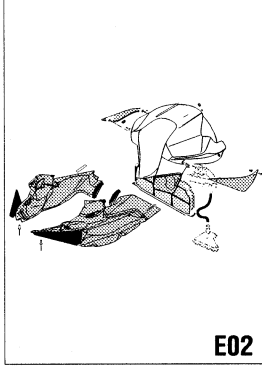
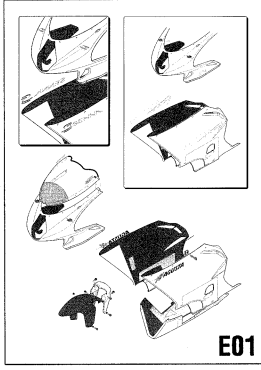
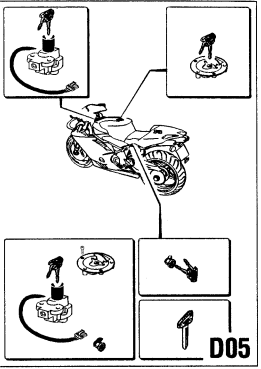
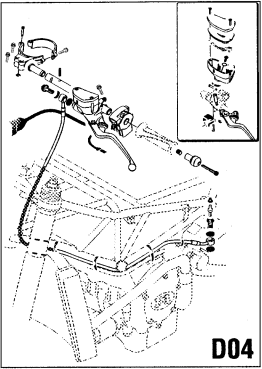
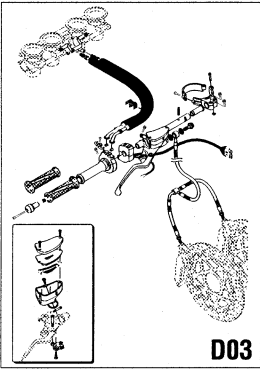
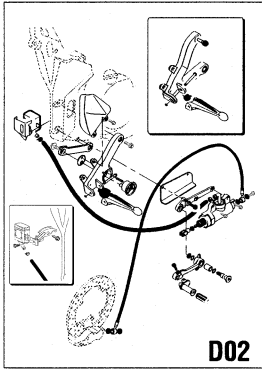
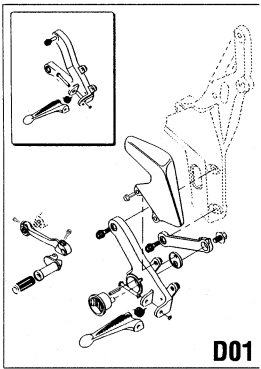



INDICE FIGURATIVO
 FIGURATIVE INDEX • INDEX FIGURATIF
 BILDVERZEICHNIS • ÍNDICE DE FIGURAS

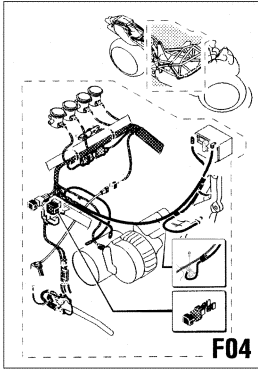

F04

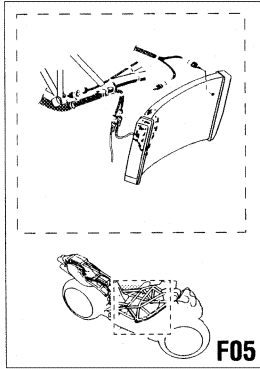

F05

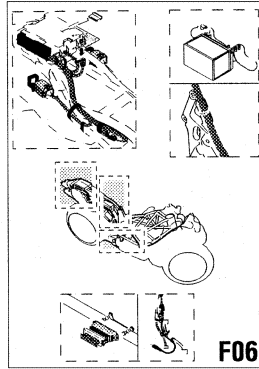

F06

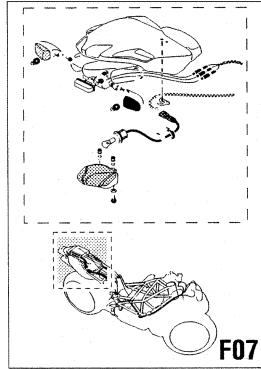

F07

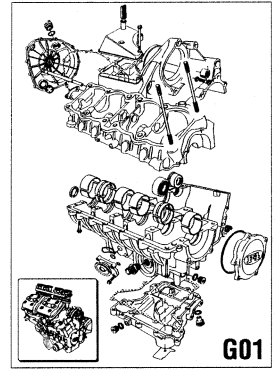

G01

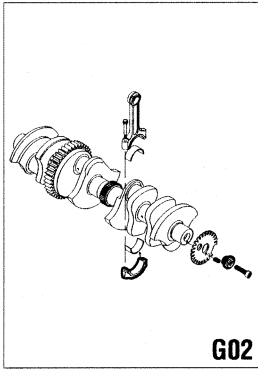

G02

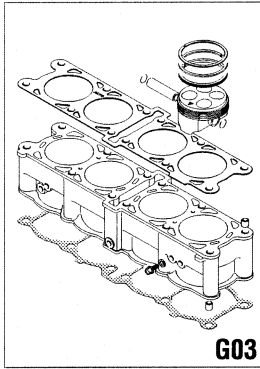

G03

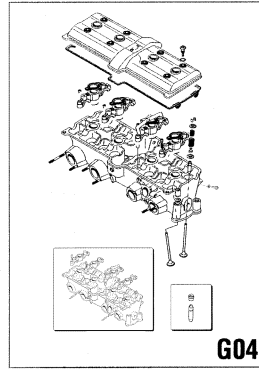

G04

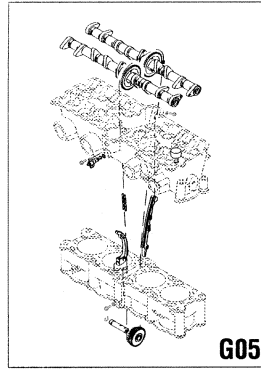

G05

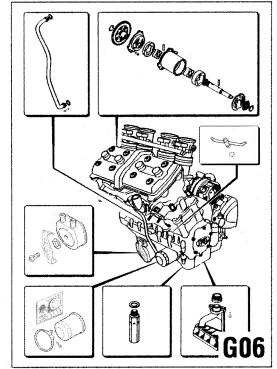

G06

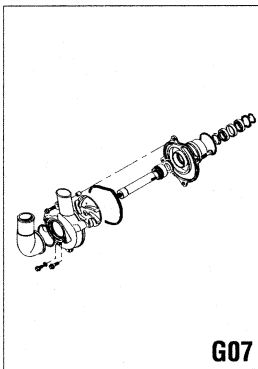

G07

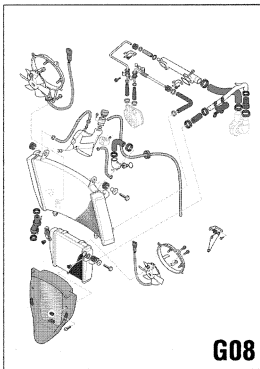

G08

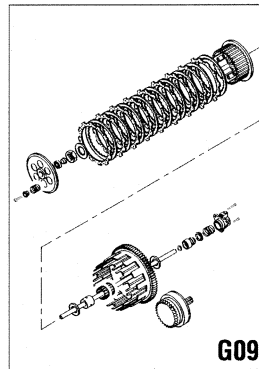

G09

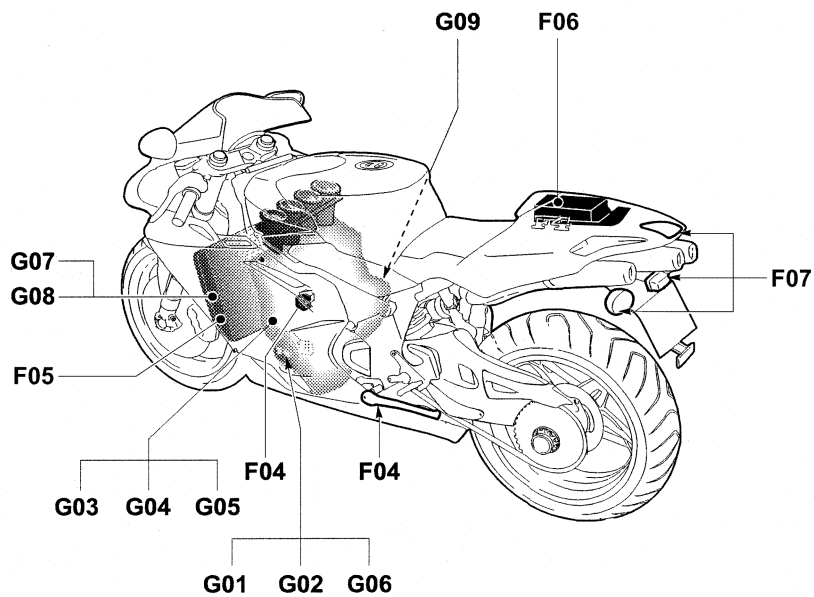

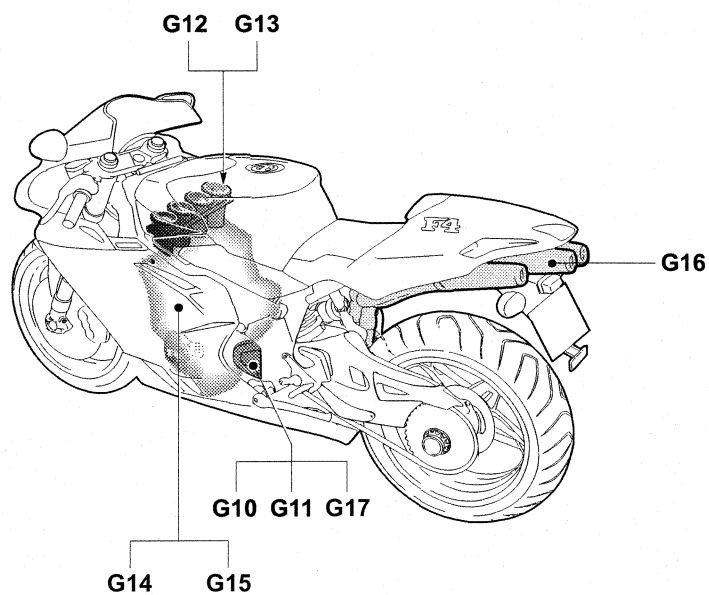
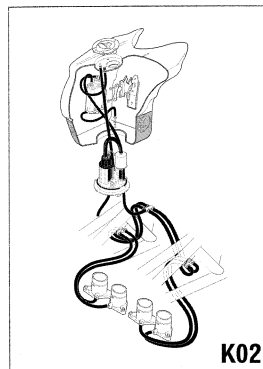
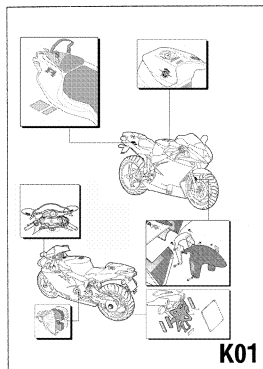
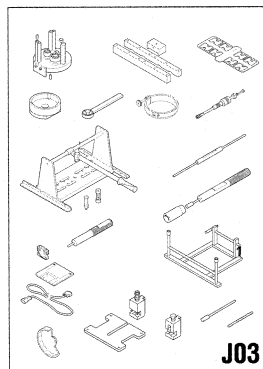
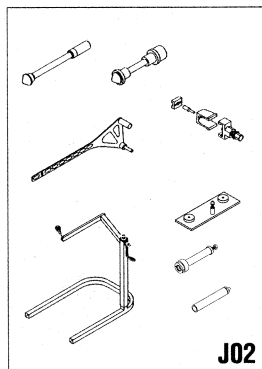
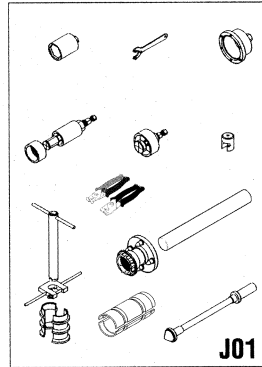
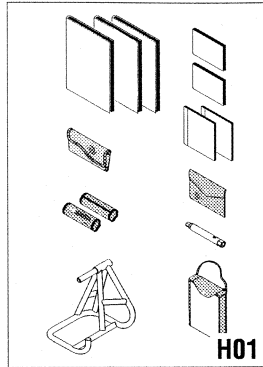
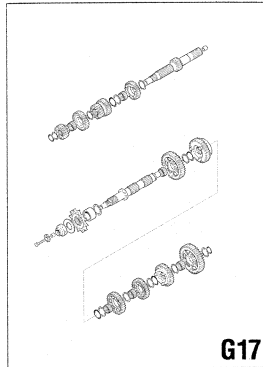
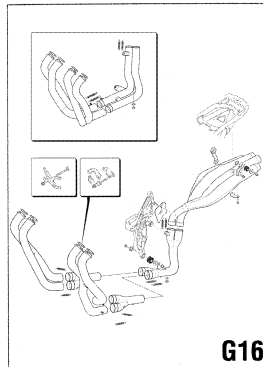
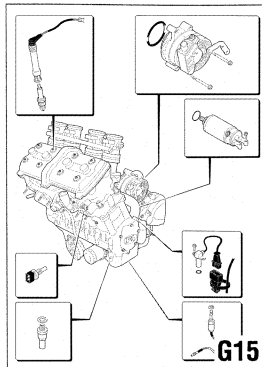
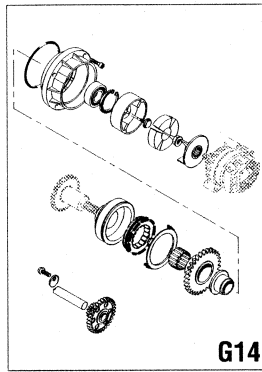
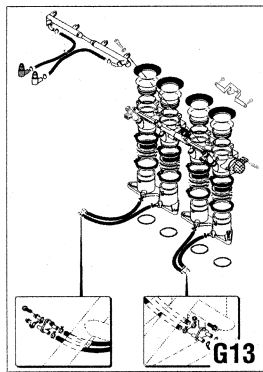
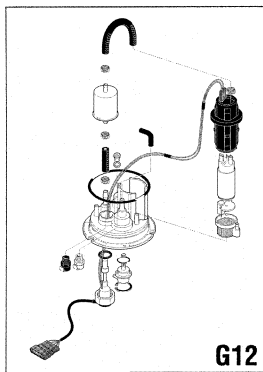
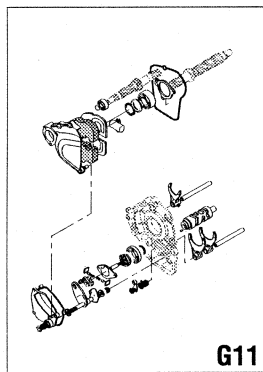
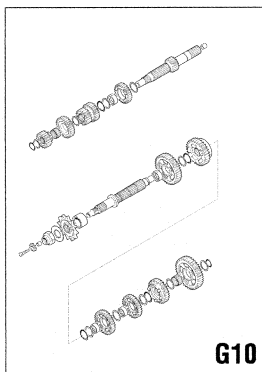



ASSIEME TELAIO
FRAME ASSEMBLY • ENSEMBLE CADRE
BAUGRUPPE RAHMEN • CONJUNTO BASTIDOR

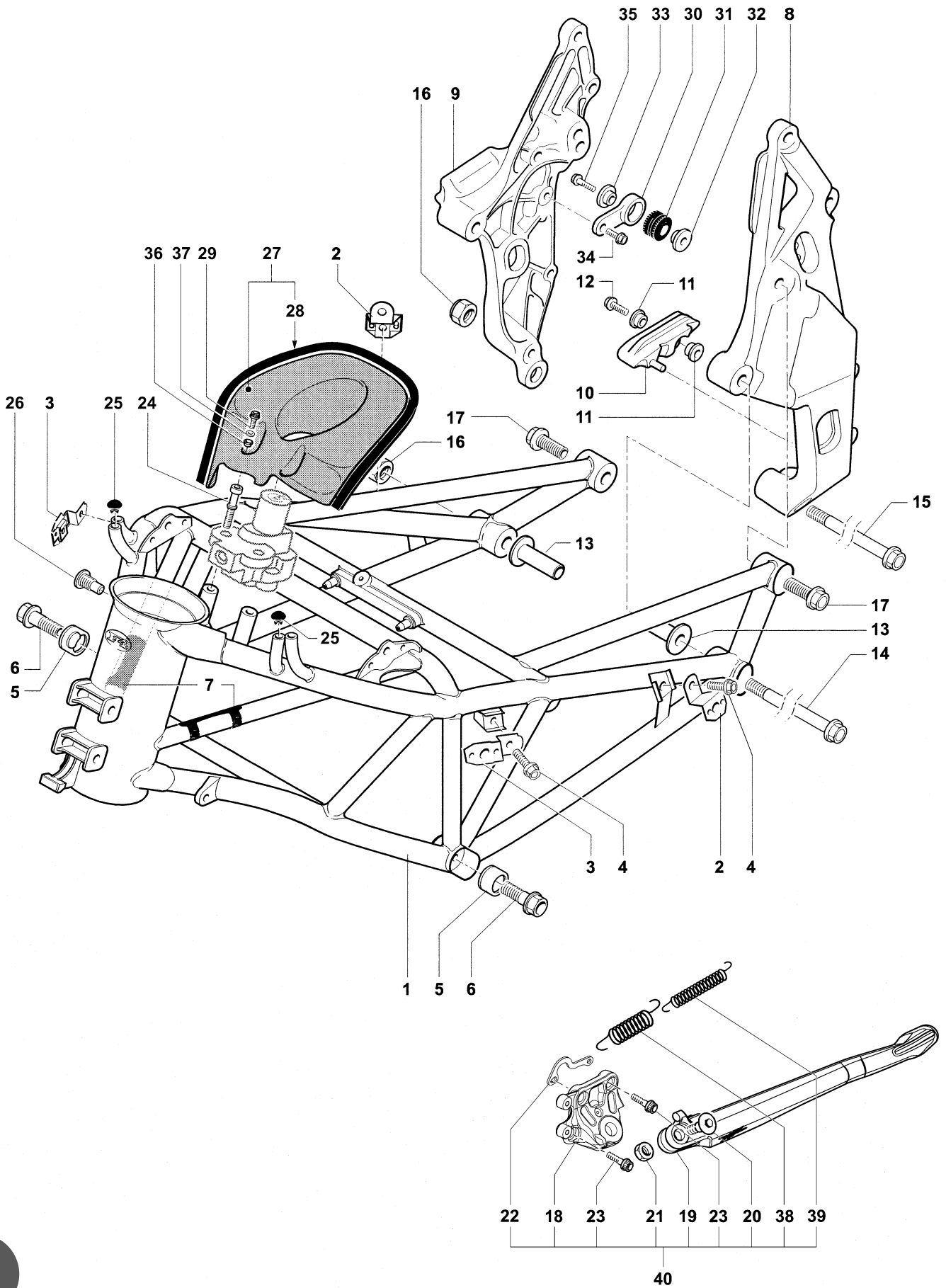

ASSIEME TELAIO

 FRAME ASSEMBLY • ENSEMBLE CADRE
 BAUGRUPPE RAHMEN • CONJUNTO BASTIDOR

N.	Code	Q.ty	Note	750 S	750 S 1+1	SPR	SR-SR1+1	SENNA	► I FRAME I ►	► I ENGINE I ►
1	800084882	1	EV02 / EV03	•	•					
1	80B084882	1	Euro 2	•	•					
1	800084882	1				•	•			
1	80A084882	1						•		
2	800089745	2		•	•	•	•	•		
3	800089747	2		•	•	•	•	•		
4	800062725	4		•	•	•	•	•		
5	800084871	2		•	•	•	•	•		
6	800084869	2		•	•	•	•	•		
7	800090417	2		•	•	•	•	•		
8	800098331	1		•	•	•	•	•		
9	800097900	1		•	•	•	•	•		
10	800087476	2		•	•	•	•	•		
11	800090392	4		•	•	•	•	•		
12	800062728	2		•	•	•	•	•		
13	8A0084857	2		•	•	•	•	•		
14	800084866	1		•	•	•	•	•		
15	800084865	1		•	•	•	•	•		
16	800042023	2		•	•	•	•	•		
17	800084867	2		•	•	•	•	•		
18	8000B4782	1	❶	•	•	•	•	•		
19	80A0B3583	1	❶	•	•	•	•	•		
20	8AA090431	1	❶	•	•	•	•	•		
21	61ND15064	1	❶	•	•	•	•	•		
22	8000B3584	1	❶	•	•	•	•	•		
23	8D00B2690	3	❶	•	•	•	•	•		
24	800097885	2		•	•	•	•			
24	800089305	2						•		
25	8B0070695	2		•	•	•	•	•		
26	800084915	1		•	•	•	•	•		
27	800093862	1		•	•		•			
27	80A093322	1				•		•		
28	800091693	1		•	•	•	•	•		
29	8D0090424	2		•	•	•	•	•		
30	800090973	1		•	•	•	•	•		
31	800062651	1		•	•	•	•	•		
32	800090943	1		•	•	•	•	•		
33	800092662	1		•	•	•	•	•		
34	800062727	1		•	•	•	•	•		
35	8H0090425	1		•	•	•	•	•		
36	800092658	2		•	•		•			
37	8000A3474	2				•		•		
38	8000B3987	1	❶	•	•	•	•	•		
39	8000B3986	1	❶	•	•	•	•	•		
40	80A0B4792	1	❷	•	•	•	•	•		

- ❶ Dopo la sostituzione del part. N° 40 - After replacement of part No. 40 - Suite à le remplacement du pièce N° 40 - Nach Wechsel von Teil Nr. 40 - Después de la sustitución de la pieza N° 40.
 ❷ Kit cavalletto laterale - Side stand kit - Kit béquille latérale - Bausatz seitlicher Ständer - Kit caballete lateral.



ASSIEME TELAIO POSTERIORE (MONOPOSTO)

REAR FRAME ASSEMBLY (SINGLE-SEATER) • ENSEMBLE CADRE ARRIÈRE (MONOPLACE)

BAUGRUPPE HINTERER RHMEN (EINSITZER) • CONJUNTO BASTIDOR TRASERO (MONOPLAZA)

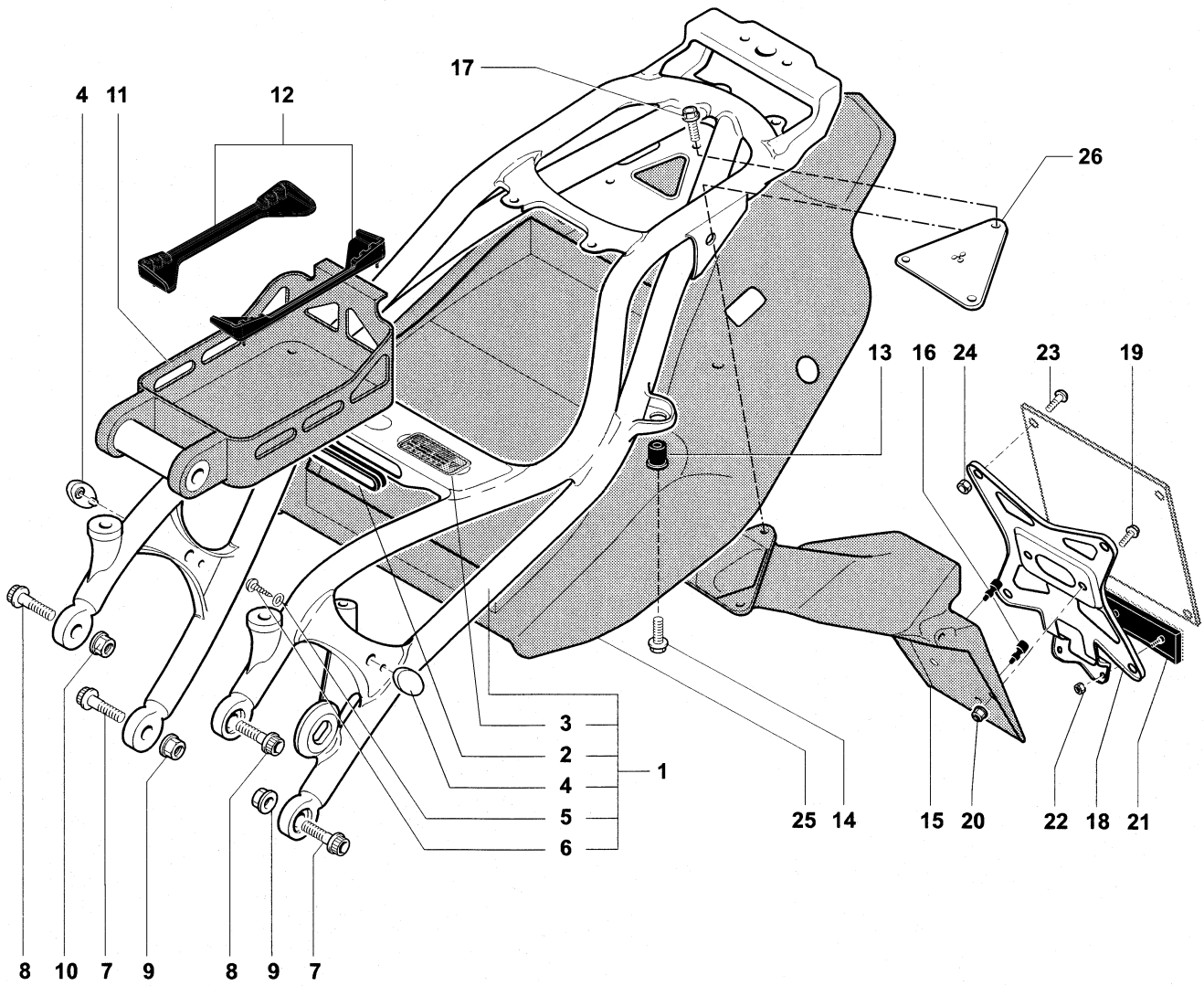

ASSIEME TELAIO POSTERIORE (MONOPOSTO)

REAR FRAME ASSEMBLY (SINGLE-SEATER) • ENSEMBLE CADRE ARRIÈRE (MONOPLACE)

BAUGRUPPE HINTERER RHMEN (EINSITZER) • CONJUNTO BASTIDOR TRASERO (MONOPLAZA)



N.	Code	Q.ty	Note	750 S	750 S 1+1	SPR	SR	SENNÀ	► I FRAME I ►	► I ENGINE I ►
1	800092889	1		•		•	•	•		
2	800087472	1		•		•	•	•		
3	800092257	1		•		•	•	•		
4	800094276	2		•		•	•	•		
5	800094313	2		•		•	•	•		
6	800081628	2		•		•	•	•		
7	8J0090426	2		•		•	•	•		
8	8K0090426	2		•		•	•	•		
9	80B043928	2		•		•	•	•		
10	800090401	1		•		•	•	•		
11	800091648	1		•		•	•	•		
12	800066339	4	EV 02	•						
			① EV 03							
12	8000A3226	2	EV 02	•						
			② EV 03							
12	8000A3226	2	Euro 2	•						
12	800066339	4	①			•	•	•		
12	8000A3226	2	②			•	•	•		
13	800048245	2		•		•	•	•		
14	800062727	2		•		•	•	•		
15	800090963	1		•		•	•	•		
16	800066308	2		•		•	•	•		
17	800062727	3		•		•	•	•		
18	800094506	1	③	•		•	•	•		
19	8H0067545	2	③	•		•	•	•		
20	800044240	2		•		•	•	•		
21	800090374	1		•		•	•	•		
22	800091033	2		•		•	•	•		
23	80A047053	4		•		•	•	•		
24	800091033	4		•		•	•	•		
25	800094174	1		•		•	•	•		
26	800095829	1		•		•	•	•		

① Prima della sostituzione del Part. N° 22 - Tavola F06 • Before replacement of Part No. 22 - Table F06 • Avant de le remplacement du pièce N° 22 - Planche F06 • Bevor Wechsel von Teil Nr. 22 - Tafel F06 • Antes de la sustitución de la pieza N° 22 - Tabla F06.

② Dopo la sostituzione del part. N° 22 - Tavola F06 • After replacement of part No. 22 - Table F06 • Suite à le remplacement du pièce N° 22 - Planche F06 • Nach Wechsel von Teil Nr. 22 - Tafel F06 • Después de la sustitución de la pieza N° 22 - Tabla F06.

③ Esclusa l'Australia (vedi tavola K01) - Australia excluded (see table K01) - Sauf l'Australie (voir planche K01) - Ausschließlich Australien (siehe Tafel K01) - Excluida la Australia (ver tabla K01).



ASSIEME TELAIO POSTERIORE (BIPOSTO)

REAR FRAME ASSEMBLY (TWO-SEATER) • ENSEMBLE CADRE ARRIÈRE (BIPLACE)

BAUGRUPPE HINTERER RAHMEN (ZWEISITZER) • CONJUNTO BASTIDOR TRASERO (BIPLAZA)

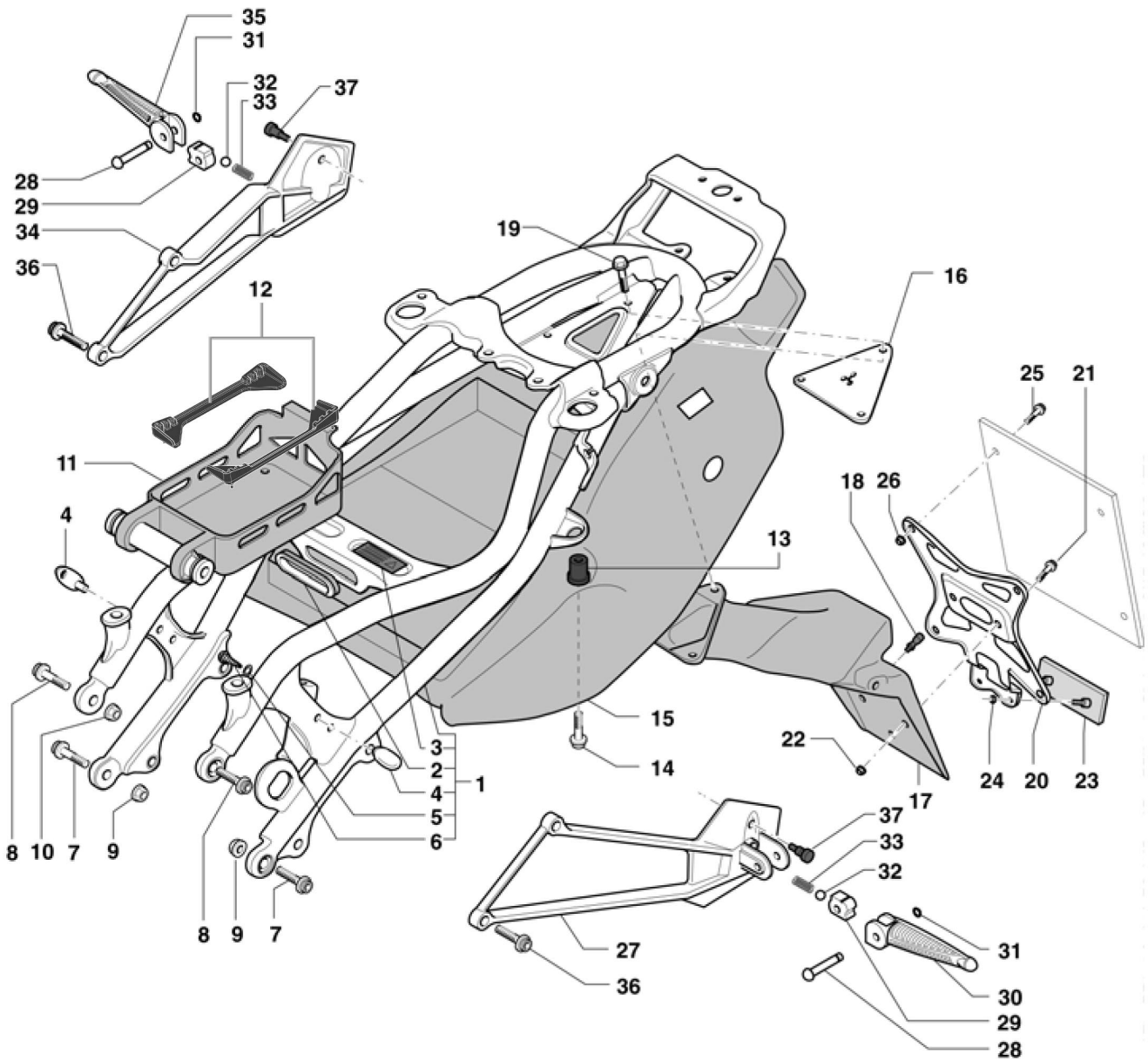

ASSIEME TELAIO POSTERIORE (BIPOSTO)

REAR FRAME ASSEMBLY (TWO-SEATER) • ENSEMBLE CADRE ARRIÈRE (BIPLACE)

BAUGRUPPE HINTERER RAHMEN (ZWEISITZER) • CONJUNTO BASTIDOR TRASERO (BIPLAZA)



N.	Code	Q.ty	Note	750 S	750 S 1+1	SPR	SR 1+1	SENNÀ	► I FRAME I ◄	► I ENGINE I ◄
1	800094164	1			•		•			
2	800087472	1			•		•			
3	800092257	1			•		•			
4	800094276	2			•		•			
5	800094313	2			•		•			
6	800081628	2			•		•			
7	8J0090426	2			•		•			
8	8K0090426	2			•		•			
9	80B043928	2			•		•			
10	800090401	1			•		•			
11	800091648	1			•		•			
12	800066339	4	① EV 02 EV 03		•					
12	8000A3226	2	② EV 02 EV 03		•					
12	8000A3226	2	Euro 2		•					
12	800066339	4	①				•			
12	8000A3226	2	②				•			
13	800048245	2			•		•			
14	800062727	2			•		•			
15	800094174	1			•		•			
16	800095829	1			•		•			
17	800090963	1			•		•			
18	800066308	2			•		•			
19	800062727	3			•		•			
20	800094506	1	③		•		•			
21	8H0067545	2	③		•		•			
22	800044240	2			•		•			
23	800090374	1			•		•			
24	800091033	2			•		•			
25	80A047053	4			•		•			
26	800091033	4			•		•			
27	80A094169	1			•		•			
28	80A053546	2			•		•			
29	800094171	2			•		•			
30	80A091661	1			•		•			
31	800090429	2			•		•			
32	6BN021507	2			•		•			
33	800094170	2			•		•			
34	80A094168	1			•		•			
35	80A091662	1			•		•			
36	8G0090426	4			•		•			
37	800095828	2			•		•			

① Prima della sostituzione del Part. N° 22 - Tavola F06 • Before replacement of Part No. 22 - Table F06 • Avant de le remplacement du pièce N° 22 - Planche F06 • Bevor Wechsel von Teil Nr. 22 - Tafel F06 • Antes de la sustitución de la pieza N° 22 - Tabla F06.

② Dopo la sostituzione del part. N° 22 - Tavola F06 • After replacement of part No. 22 - Table F06 • Suite à le remplacement du pièce N° 22 - Planche F06 • Nach Wechsel von Teil Nr. 22 - Tafel F06 • Después de la sustitución de la pieza N° 22 - Tabla F06.

③ Esclusa l'Australia (vedi tavola K01) - Australia excluded (see table K01) - Sauf l'Australie (voir planche K01) - Ausschließlich Australien (siehe Tafel K01) - Excluida la Australia (ver tabla K01).



ASSIEME FORCELLONE
SWINGING ARM ASSEMBLY • ENSEMBLE FOURCHE
BAUGRUPPE GABEL • CONJUNTO HORQUILLA

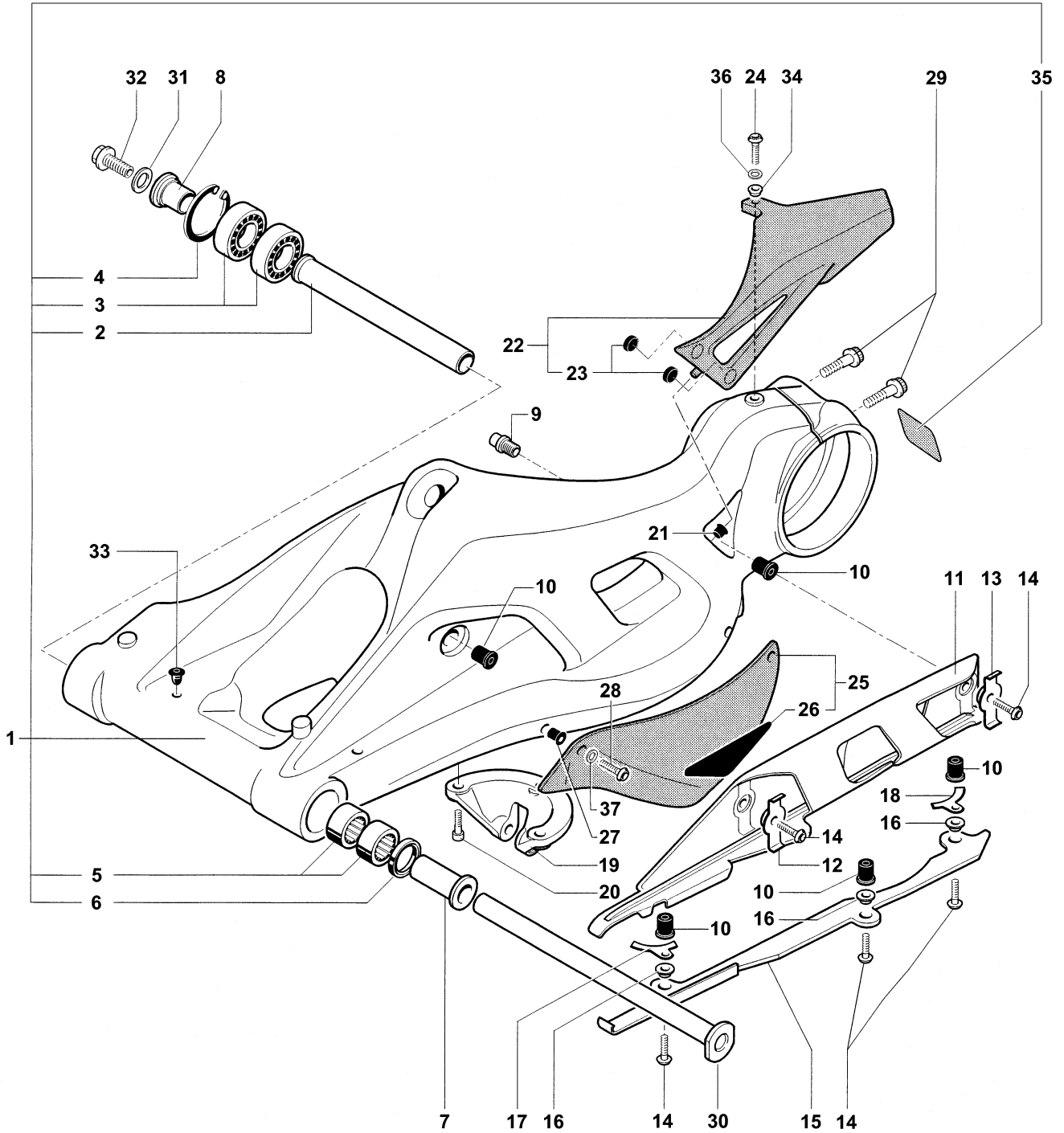

ASSIEME FORCELLONE

SWINGING ARM ASSEMBLY • ENSEMBLE FOURCHE
BAUGRUPPE GABEL • CONJUNTO HORQUILLA



N.	Code	Q.ty	Note	750 S	750 S 1+1	SPR	SR-SR1+1	SENNÀ	► I FRAME I ◄	► I ENGINE I ◄
1	800093854	1		•	•	•	•	•		
2	800084872	1		•	•	•	•	•		
3	800084938	2		•	•	•	•	•		
4	800084939	1		•	•	•	•	•		
5	800084936	2		•	•	•	•	•		
6	800084937	1		•	•	•	•	•		
7	800084859	1		•	•	•	•	•		
8	800084873	1		•	•	•	•	•		
9	800090399	1		•	•	•	•	•		
10	800048245	5		•	•	•	•	•		
11	800087473	1		•	•	•	•	•		
12	800087463	1		•	•	•	•	•		
13	800089300	1		•	•	•	•	•		
14	800089786	5		•	•	•	•	•		
15	800087475	1		•	•	•	•	•		
16	800090391	3		•	•	•	•	•		
17	800090998	1		•	•	•	•	•		
18	800090999	1		•	•	•	•	•		
19	800087441	1		•	•	•	•	•		
20	8L0082751	3		•	•	•	•	•		
21	800092631	1		•	•	•	•	•		
22	800092849	1		•	•	•	•	•		
22	80A092671	1				•		•		
23	800090979	2		•	•	•	•	•		
24	8A0089786	1		•	•	•	•	•		
25	800093855	1		•	•	•	•	•		
25	80A0A2754	1				•				
25	8000A3935	1					•			
25	80A0A0963	1						•		
26	800092667	1		•	•	•	•	•		
26	8000A2753	1				•	•			
26	8000A0964	1						•		
27	800091022	2		•	•	•	•	•		
28	8A0090901	2		•	•	•	•	•		
29	800078221	2		•	•	•	•	•		
30	800091655	1		•	•	•	•	•		
31	800086396	1		•	•	•	•	•		
32	800086395	1		•	•	•	•	•		
33	800094895	1		•	•	•	•	•		
34	800092670	1		•	•	•	•	•		
35	8000A2734	1		•	•	•	•	•		
36	800089751	1				•		•		
37	800092882	2				•		•		



ASSIEME SOSPENSIONE POSTERIORE

REAR SUSPENSION ASSEMBLY • ENSEMBLE SUSPENSION ARRIÈRE

BAUGRUPPE HINTERRADAUFHÄNGUNG • CONJUNTO SUSPENSIÓN TRASERA

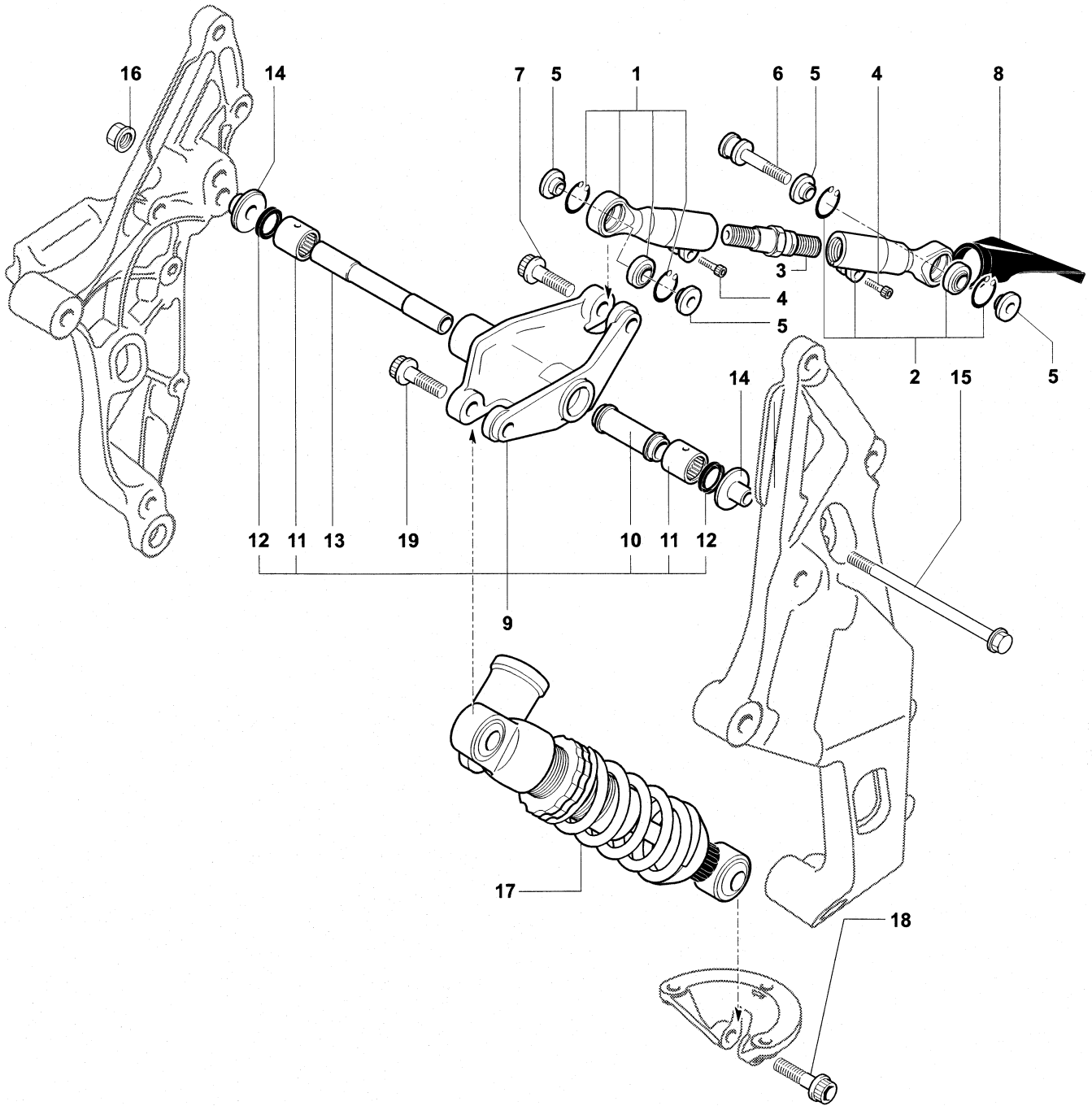

ASSIEME SOSPENSIONE POSTERIORE

REAR SUSPENSION ASSEMBLY • ENSEMBLE SUSPENSION ARRIÈRE

BAUGRUPPE HINTERRADAUFHÄNGUNG • CONJUNTO SUSPENSIÓN TRASERA



N.	Code	Q.ty	Note	750 S	750 S 1+1	SPR	SR-SR1+1	SENNA	► I FRAME I ►	► I ENGINE I ►
1	800093318	1		•	•	•	•	•		
2	800093319	1		•	•	•	•	•		
3	800084875	1	EV 02 / EV 03	•	•					
3	8000A4508	1	Euro 2	•	•					
3	800084875	1				•	•	•		
4	8G0090425	2		•	•	•	•	•		
5	800084874	4		•	•	•	•	•		
6	800084868	1		•	•	•	•	•		
7	8P0082751	1		•	•	•	•	•		
8	800091027	1		•	•	•	•	•		
9	800093320	1		•	•	•	•	•		
10	800089757	1		•	•	•	•	•		
11	800084945	2		•	•	•	•	•		
12	800084946	2		•	•	•	•	•		
13	800084858	1		•	•	•	•	•		
14	800086447	2		•	•	•	•	•		
15	800084863	1		•	•	•	•	•		
16	800042022	1		•	•	•	•	•		
17	800094187	1	EV 02	•						
17	8000A1556	1	EV 03 / Euro 2	•						
17	800094187	1			•					
17	8000A1486	1				•	•			
17	8000A0962	1						•		
18	8S0082751	1		•	•	•	•	•		
19	8R0082751	1		•	•	•	•	•		



ASSIEME SOSPENSIONE ANTERIORE

FRONT SUSPENSION ASSEMBLY • ENSEMBLE SUSPENSION AVANT

BAUGRUPPE VORDERRADAUFHÄNGUNG • CONJUNTO SUSPENSIÓN DELANTERA

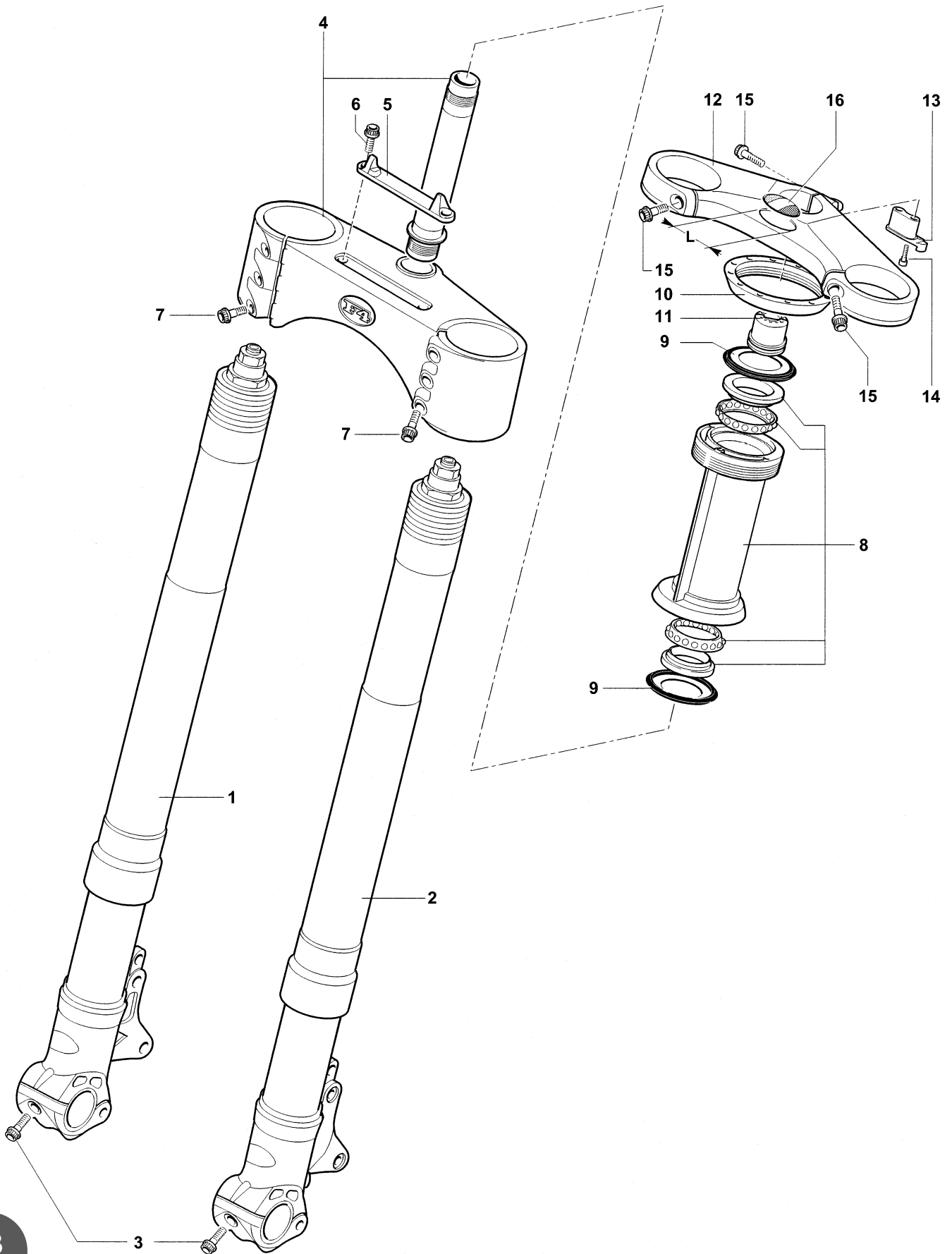

ASSIEME SOSPENSIONE ANTERIORE

FRONT SUSPENSION ASSEMBLY • ENSEMBLE SUSPENSION AVANT

BAUGRUPPE VORDERRADAUFHÄNGUNG • CONJUNTO SUSPENSIÓN DELANTERA



N.	Code	Q.ty	Note	750 S	750 S 1+1	SPR	SR-SR1+1	SENNA	► I FRAME I ►	► I ENGINE I ►
1	800092846	1		•	•		•			
1	80A098726	1				•				
1	80A092846	1						•	► I 004885	
1	80A098726	1						•	005464 I ►	
1	80A092846	1	USA					•		
2	800092845	1		•	•		•			
2	80A098727	1				•				
2	80A092845	1						•	► I 004885	
2	80A098727	1						•	005464 I ►	
2	80A092845	1	USA					•		
3	800082708	2		•	•		•			
3	800082708	2						•	► I 004885	
3	800082708	2	USA					•		
4	800093852	1		•	•	•	•	•		
5	800086407	1		•	•	•	•	•		
6	8E0090425	2		•	•	•	•	•		
7	8H0090425	6		•	•	•	•	•		
8	800090279	1		•	•	•	•	•		
9	800090897	2		•	•	•	•	•		
10	800086436	1		•	•	•	•	•		
11	800090280	1		•	•	•	•	•		
12	800090282	1	L=36 mm	•	•	•	•			
12	8A0090282	1	L=60 mm					•		
13	800089783	1		•	•	•	•	•		
14	8L0090424	2		•	•	•	•	•		
15	8G0090426	3		•	•	•	•	•		
16	800091642	1		•	•					



FORCELLA DESTRA (F4 S / S 1+1 / SR / SENNA)

RIGHT-HAND FORK (F4 S / S 1+1 / SR / SENNA) • FOURCHE DROITE (F4 S / S 1+1 / SR / SENNA)

RECHTE GABEL (F4 S / S 1+1 / SR / SENNA) • HORQUILLA DERECHA (F4 S / S 1+1 / SR / SENNA)

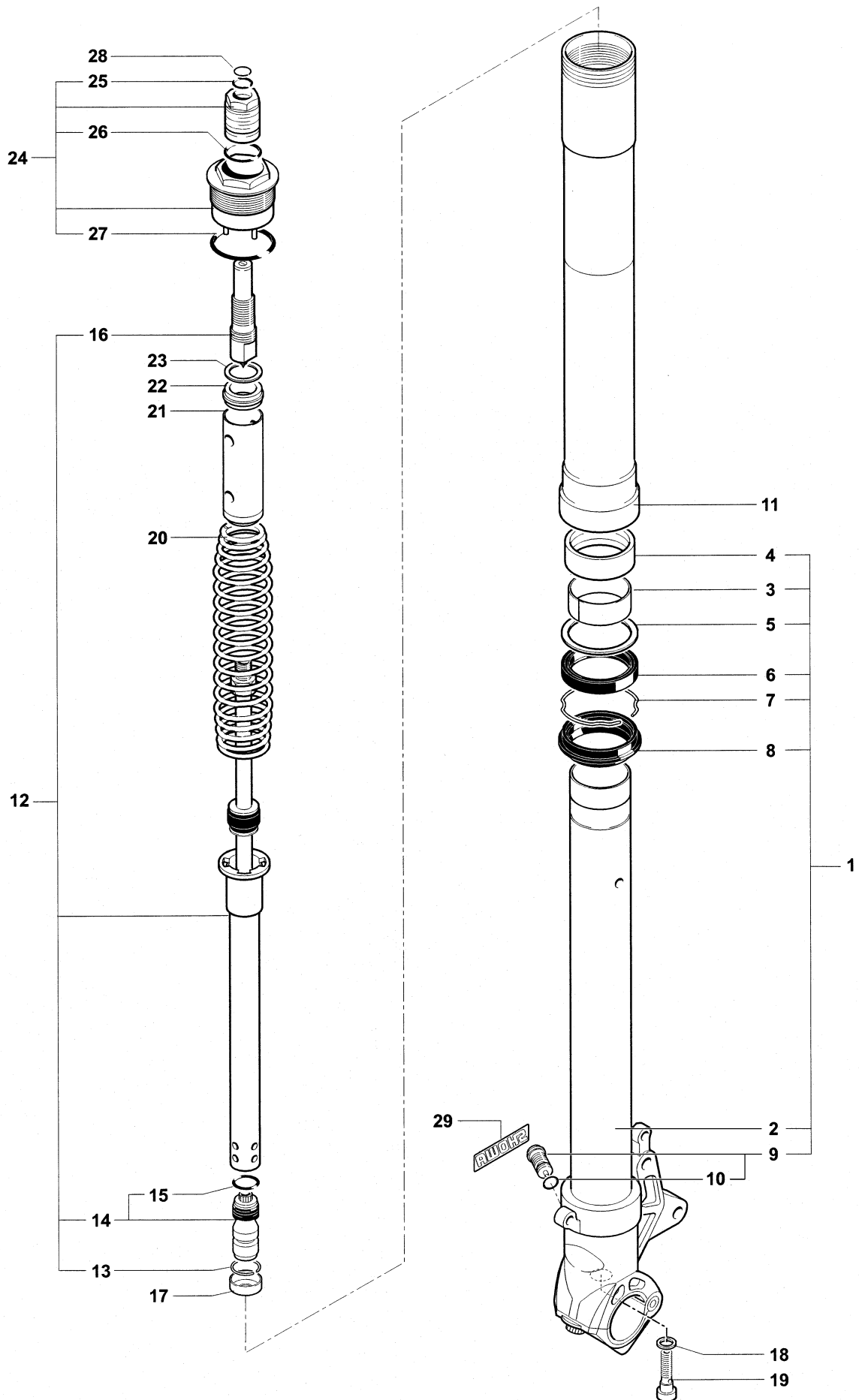

FORCELLA DESTRA (F4 S / S 1+1 / SR / SENNA)

RIGHT-HAND FORK (F4 S / S 1+1 / SR / SENNA) • FOURCHE DROITE (F4 S / S 1+1 / SR / SENNA)

RECHTE GABEL (F4 S / S 1+1 / SR / SENNA) • HORQUILLA DERECHA (F4 S / S 1+1 / SR / SENNA)



N.	Code	Q.ty	Note	750 S	750 S 1+1	SPR	SR-SR1+1	SENNA	► I FRAME I ◄	► I ENGINE I ◄
1	800093360	1		•	•		•			
1	80A093360	1						•	► I 004885	
1	80A093360	1	USA					•		
2	800093404	1		•	•		•			
2	80A093404	1						•	► I 004885	
2	80A093404	1	USA					•		
3	800093361	1		•	•		•			
3	800093361	1						•	► I 004885	
3	800093361	1	USA					•		
4	800093362	1		•	•		•			
4	800093362	1						•	► I 004885	
4	800093362	1	USA					•		
5	800093363	1		•	•		•			
5	800093363	1						•	► I 004885	
5	800093363	1	USA					•		
6	800093364	1		•	•		•			
6	800093364	1						•	► I 004885	
6	800093364	1	USA					•		
7	800093365	1		•	•		•			
7	800093365	1						•	► I 004885	
7	800093365	1	USA					•		
8	800093366	1		•	•		•			
8	800093366	1						•	► I 004885	
8	800093366	1	USA					•		
9	800093367	1		•	•		•			
9	800093367	1						•	► I 004885	
9	800093367	1	USA					•		
10	800093368	1		•	•		•			
10	800093368	1						•	► I 004885	
10	800093368	1	USA					•		
11	800093370	1		•	•		•			
11	800093370	1						•	► I 004885	
11	800093370	1	USA					•		
12	800093371	1		•	•		•			
12	800093371	1						•	► I 004885	
12	800093371	1	USA					•		
13	800093372	1		•	•		•			
13	800093372	1						•	► I 004885	
13	800093372	1	USA					•		
14	800093373	1		•	•		•			
14	800093373	1						•	► I 004885	
14	800093373	1	USA					•		
15	800073558	1		•	•		•			
15	800073558	1						•	► I 004885	
15	800073558	1	USA					•		
16	800093374	1		•	•		•			
16	800093374	1						•	► I 004885	
16	800093374	1	USA					•		
17	800093391	1		•	•		•			
17	800093391	1						•	► I 004885	
17	800093391	1	USA					•		
18	800093392	1		•	•		•			
18	800093392	1						•	► I 004885	
18	800093392	1	USA					•		





FORCELLA DESTRA (F4 S / S 1+1 / SR / SENNA)

RIGHT-HAND FORK (F4 S / S 1+1 / SR / SENNA) • FOURCHE DROITE (F4 S / S 1+1 / SR / SENNA)

RECHTE GABEL (F4 S / S 1+1 / SR / SENNA) • HORQUILLA DERECHA (F4 S / S 1+1 / SR / SENNA)

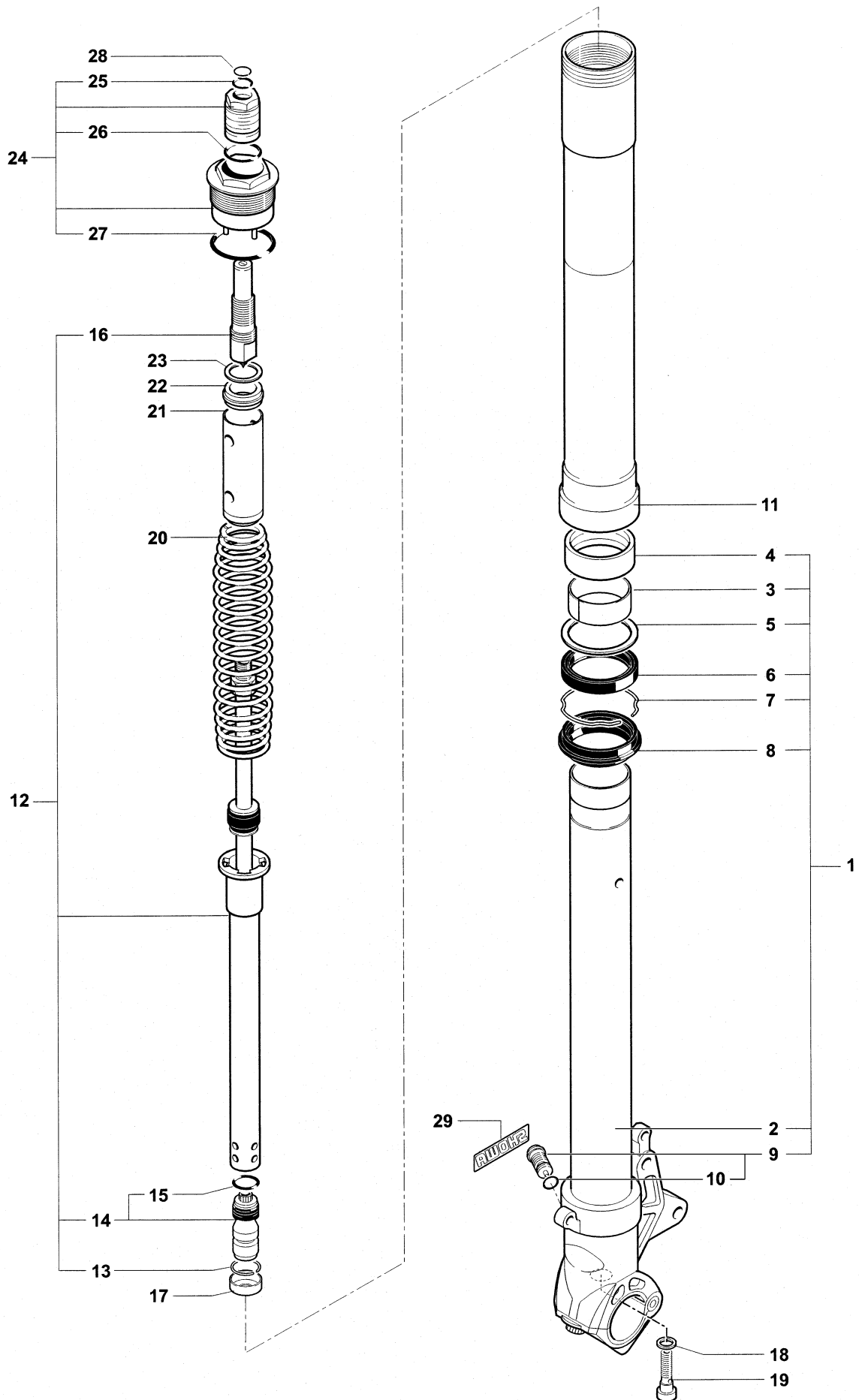

FORCELLA DESTRA (F4 S / S 1+1 / SR / SENNA)

RIGHT-HAND FORK (F4 S / S 1+1 / SR / SENNA) • FOURCHE DROITE (F4 S / S 1+1 / SR / SENNA)

RECHTE GABEL (F4 S / S 1+1 / SR / SENNA) • HORQUILLA DERECHA (F4 S / S 1+1 / SR / SENNA)



N.	Code	Q.ty	Note	750 S	750 S 1+1	SPR	SR-SR1+1	SENNA	► I FRAME I ◄	► I ENGINE I ◄
19	800093393	1		•	•		•			
19	800093393	1						•	► I 004885	
19	800093393	1	USA					•		
20	800093394	1		•	•		•			
20	800093394	1						•	► I 004885	
20	800093394	1	USA					•		
21	800093395	1		•	•		•			
21	800093395	1						•	► I 004885	
21	800093395	1	USA					•		
22	800093396	1		•	•		•			
22	800093396	1						•	► I 004885	
22	800093396	1	USA					•		
23	800093397	1		•	•		•			
23	800093397	1						•	► I 004885	
23	800093397	1	USA					•		
24	800093398	1		•	•		•			
24	800093398	1						•	► I 004885	
24	800093398	1	USA					•		
25	800093399	1		•	•		•			
25	800093399	1						•	► I 004885	
25	800093399	1	USA					•		
26	800093400	1		•	•		•			
26	800093400	1						•	► I 004885	
26	800093400	1	USA					•		
27	800093401	1		•	•		•			
27	800093401	1						•	► I 004885	
27	800093401	1	USA					•		
28	800093402	1		•	•		•			
28	800093402	1						•	► I 004885	
28	800093402	1	USA					•		
29	800093406	1		•	•		•			





FORCELLA SINISTRA (F4 S / S 1+1 / SR / SENNA)

LEFT-HAND FORK (F4 S / S 1+1 / SR / SENNA) • FOURCHE GAUCHE (F4 S / S 1+1 / SR / SENNA)

LINKE GABEL (F4 S / S 1+1 / SR / SENNA) • HORQUILLA IZQUIERDA (F4 S / S 1+1 / SR / SENNA)

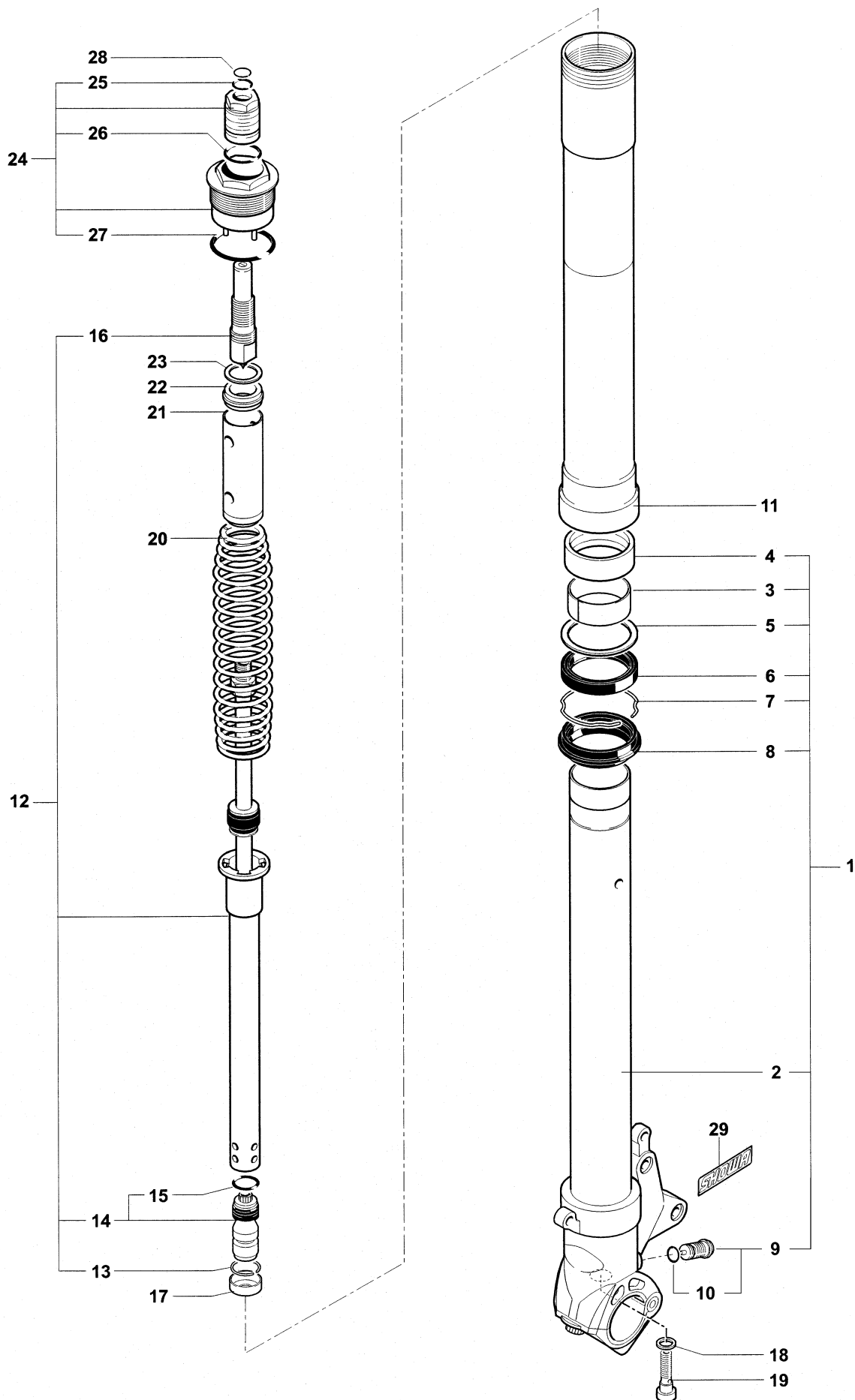

FORCELLA SINISTRA (F4 S / S 1+1 / SR / SENNA)

LEFT-HAND FORK (F4 S / S 1+1 / SR / SENNA) • FOURCHE GAUCHE (F4 S / S 1+1 / SR / SENNA)

LINKE GABEL (F4 S / S 1+1 / SR / SENNA) • HORQUILLA IZQUIERDA (F4 S / S 1+1 / SR / SENNA)



N.	Code	Q.ty	Note	750 S	750 S 1+1	SPR	SR-SR1+1	SENNA	► I FRAME I ◄	► I ENGINE I ◄
1	800093359	1		•	•		•			
1	80A093359	1						•	► I 004885	
1	80A093359	1	USA					•		
2	800093403	1		•	•		•			
2	80A093403	1						•	► I 004885	
2	80A093403	1	USA					•		
3	800093361	1		•	•		•			
3	800093361	1						•	► I 004885	
3	800093361	1	USA					•		
4	800093362	1		•	•		•			
4	800093362	1						•	► I 004885	
4	800093362	1	USA					•		
5	800093363	1		•	•		•			
5	800093363	1						•	► I 004885	
5	800093363	1	USA					•		
6	800093364	1		•	•		•			
6	800093364	1						•	► I 004885	
6	800093364	1	USA					•		
7	800093365	1		•	•		•			
7	800093365	1						•	► I 004885	
7	800093365	1	USA					•		
8	800093366	1		•	•		•			
8	800093366	1						•	► I 004885	
8	800093366	1	USA					•		
9	800093367	1		•	•		•			
9	800093367	1						•	► I 004885	
9	800093367	1	USA					•		
10	800093368	1		•	•		•			
10	800093368	1						•	► I 004885	
10	800093368	1	USA					•		
11	800093370	1		•	•		•			
11	800093370	1						•	► I 004885	
11	800093370	1	USA					•		
12	800093371	1		•	•		•			
12	800093371	1						•	► I 004885	
12	800093371	1	USA					•		
13	800093372	1		•	•		•			
13	800093372	1						•	► I 004885	
13	800093372	1	USA					•		
14	800093373	1		•	•		•			
14	800093373	1						•	► I 004885	
14	800093373	1	USA					•		
15	800073558	1		•	•		•			
15	800073558	1						•	► I 004885	
15	800073558	1	USA					•		
16	800093374	1		•	•		•			
16	800093374	1						•	► I 004885	
16	800093374	1	USA					•		
17	800093391	1		•	•		•			
17	800093391	1						•	► I 004885	
17	800093391	1	USA					•		
18	800093392	1		•	•		•			
18	800093392	1						•	► I 004885	
18	800093392	1	USA					•		





FORCELLA SINISTRA (F4 S / S 1+1 / SR / SENNA)

LEFT-HAND FORK (F4 S / S 1+1 / SR / SENNA) • FOURCHE GAUCHE (F4 S / S 1+1 / SR / SENNA)

LINKE GABEL (F4 S / S 1+1 / SR / SENNA) • HORQUILLA IZQUIERDA (F4 S / S 1+1 / SR / SENNA)

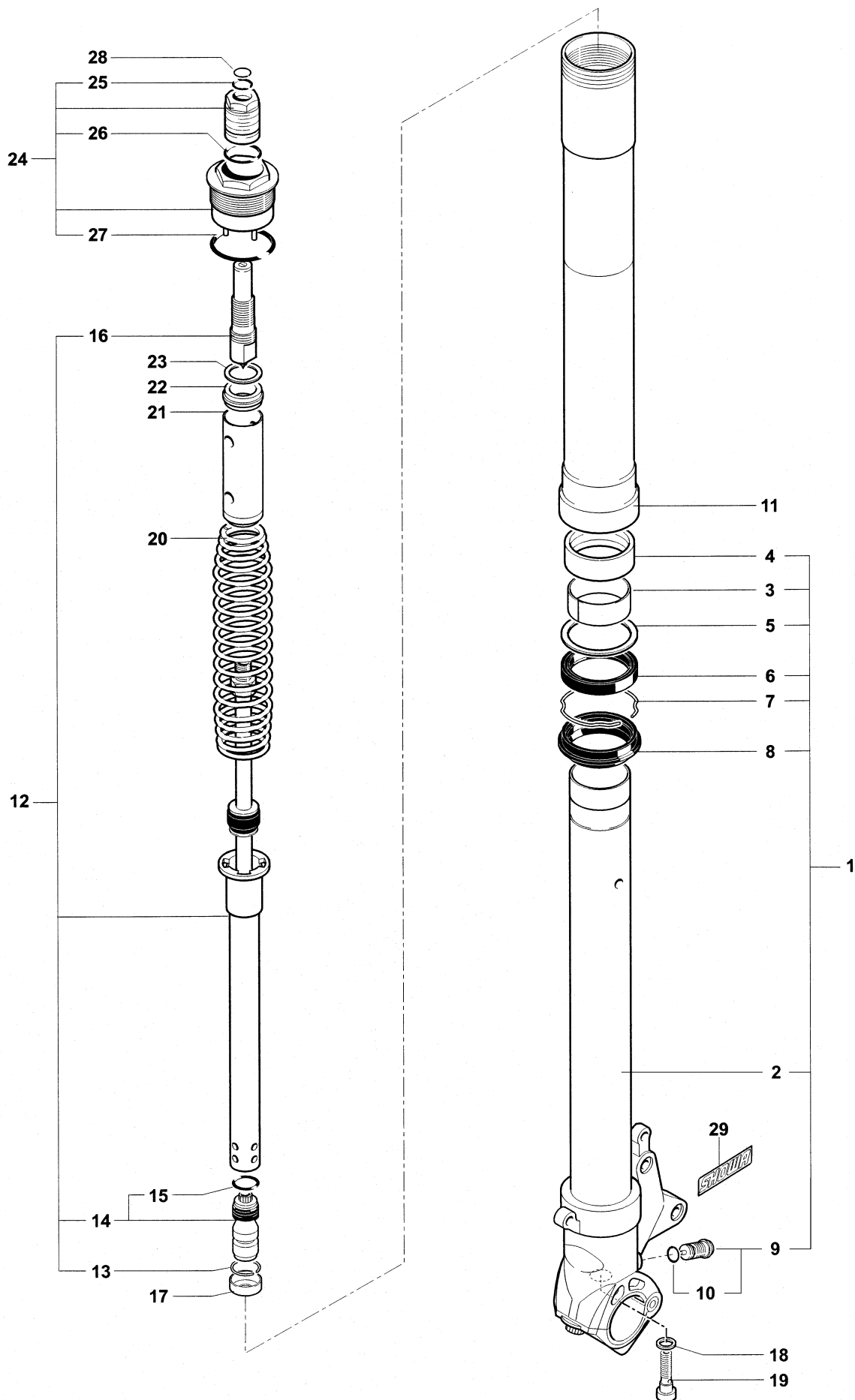

FORCELLA SINISTRA (F4 S / S 1+1 / SR / SENNA)

LEFT-HAND FORK (F4 S / S 1+1 / SR / SENNA) • FOURCHE GAUCHE (F4 S / S 1+1 / SR / SENNA)

LINKE GABEL (F4 S / S 1+1 / SR / SENNA) • HORQUILLA IZQUIERDA (F4 S / S 1+1 / SR / SENNA)



N.	Code	Q.ty	Note	750 S	750 S 1+1	SPR	SR-SR1+1	SENNA	► I FRAME I ◄	► I ENGINE I ◄
19	800093393	1		•	•		•			
19	800093393	1						•	► I 004885	
19	800093393	1	USA					•		
20	800093394	1		•	•		•			
20	800093394	1						•	► I 004885	
20	800093394	1	USA					•		
21	800093395	1		•	•		•			
21	800093395	1						•	► I 004885	
21	800093395	1	USA					•		
22	800093396	1		•	•		•			
22	800093396	1						•	► I 004885	
22	800093396	1	USA					•		
23	800093397	1		•	•		•			
23	800093397	1						•	► I 004885	
23	800093397	1	USA					•		
24	800093398	1		•	•		•			
24	800093398	1						•	► I 004885	
24	800093398	1	USA					•		
25	800093399	1		•	•		•			
25	800093399	1						•	► I 004885	
25	800093399	1	USA					•		
26	800093400	1		•	•		•			
26	800093400	1						•	► I 004885	
26	800093400	1	USA					•		
27	800093401	1		•	•		•			
27	800093401	1						•	► I 004885	
27	800093401	1	USA					•		
28	800093402	1		•	•		•			
28	800093402	1						•	► I 004885	
28	800093402	1	USA					•		
29	800093406	1		•	•		•			





FORCELLA DESTRA (F4 SPR / SENNA)

RIGHT-HAND FORK (F4 SPR / SENNA) • FOURCHE DROITE (F4 SPR / SENNA)
RECHTE GABEL (F4 SPR / SENNA) • HORQUILLA DERECHA (F4 SPR / SENNA)

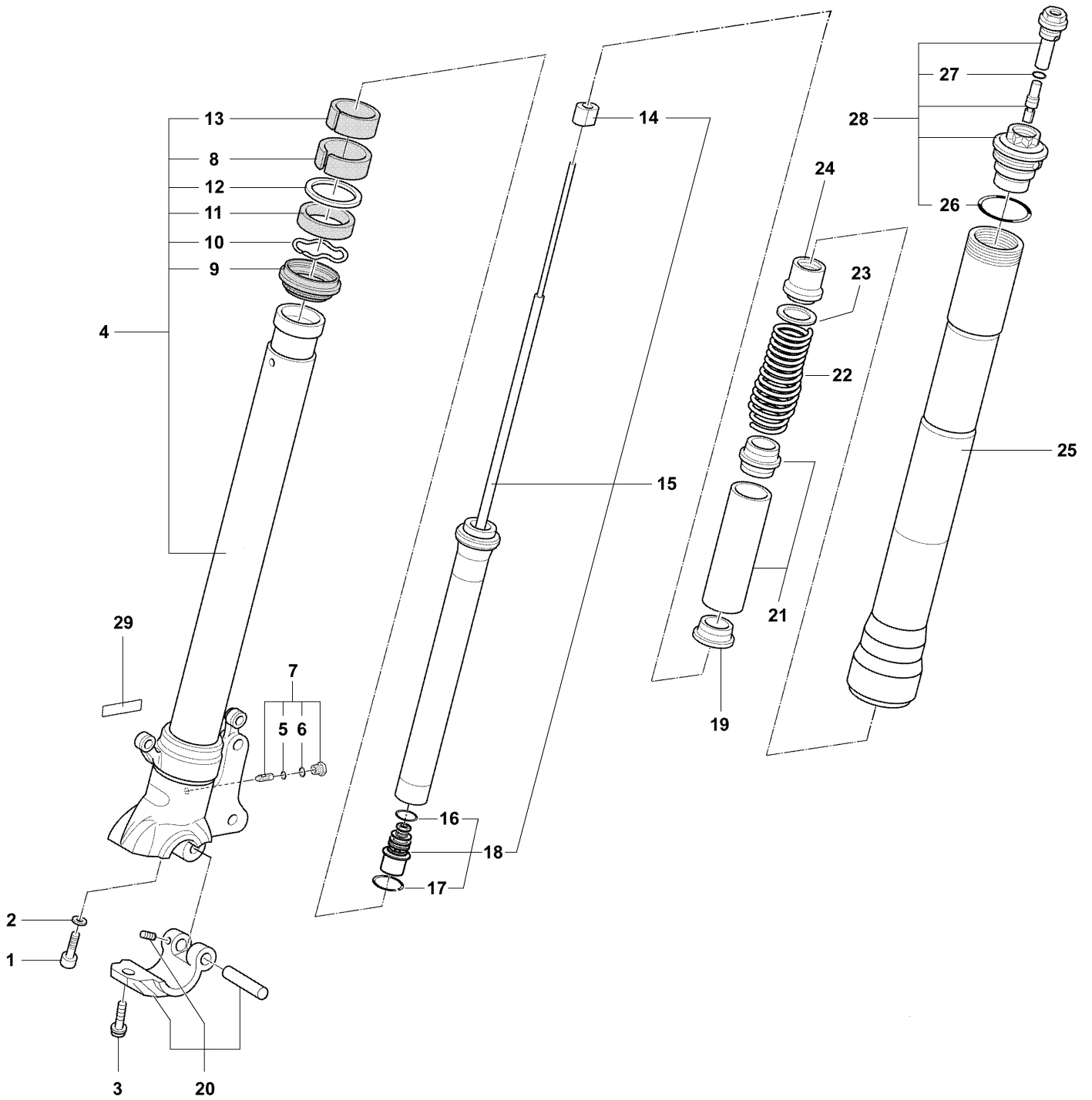

FORCELLA DESTRA (F4 SPR / SENNA)

 RIGHT-HAND FORK (F4 SPR / SENNA) • FOURCHE DROITE (F4 SPR / SENNA)
 RECHTE GABEL (F4 SPR / SENNA) • HORQUILLA DERECHA (F4 SPR / SENNA)

N.	Code	Q.ty	Note	750 S	750 S 1+1	SPR	SR-SR1+1	SENNA	► I FRAME I ►	► I ENGINE I ►
1	8000A0841	1				•				
1	8000A0841	1	①					•	005464 I ►	
2	800031113	1				•				
2	800031113	1	①					•	005464 I ►	
3	800082708	1				•				
3	800082708	1	①					•	005464 I ►	
4	80A0A1858	1				•				
4	80A0A1858	1	①					•	005464 I ►	
5	8000A0826	1				•				
5	8000A0826	1	①					•	005464 I ►	
6	800050679	1				•				
6	800050679	1	①					•	005464 I ►	
7	8000A1859	1				•				
7	8000A1859	1	①					•	005464 I ►	
8	8000A1860	1				•				
8	8000A1860	1	①					•	005464 I ►	
9	800086501	1				•				
9	800086501	1	①					•	005464 I ►	
10	800089274	1				•				
10	800089274	1	①					•	005464 I ►	
11	800086500	1				•				
11	800086500	1	①					•	005464 I ►	
12	800089275	1				•				
12	800089275	1	①					•	005464 I ►	
13	800086503	1				•				
13	800086503	1	①					•	005464 I ►	
14	800081174	1				•				
14	800081174	1	①					•	005464 I ►	
15	8000A2216	1				•				
15	8000A2216	1	①					•	005464 I ►	
16	800019789	1				•				
16	800019789	1	①					•	005464 I ►	
17	800081164	1				•				
17	800081164	1	①					•	005464 I ►	
18	8000A2217	1				•				
18	8000A2217	1	①					•	005464 I ►	
19	8000A1863	1				•				
19	8000A1863	1	①					•	005464 I ►	
20	8000A1864	1				•				
20	8000A1864	1	①					•	005464 I ►	
21	8000A2218	1				•				
21	8000A2218	1	①					•	005464 I ►	
22	8000A2219	1				•				
22	8000A2219	1	①					•	005464 I ►	
23	8000A1867	1				•				
23	8000A1867	1	①					•	005464 I ►	
24	8000A1868	1				•				
24	8000A1868	1	①					•	005464 I ►	
25	8000A1869	1				•				
25	8000A1869	1	①					•	005464 I ►	
26	8000A1870	1				•				
26	8000A1870	1	①					•	005464 I ►	
27	8000A0817	1				•				
27	8000A0817	1	①					•	005464 I ►	
28	8000A1871	1				•				
28	8000A1871	1	①					•	005464 I ►	
29	8000A1872	1				•				
29	8000A1872	1	①					•	005464 I ►	

① Esclusi gli USA - USA excluded - Sauf les USA - Ausschließlich USA - Excluidos los USA

B06

2



FORCELLA SINISTRA (F4 SPR / SENNA)

LEFT-HAND FORK (F4 SPR / SENNA) • FOURCHE GAUCHE (F4 SPR / SENNA)
LINKE GABEL (F4 SPR / SENNA) • HORQUILLA IZQUIERDA (F4 SPR / SENNA)

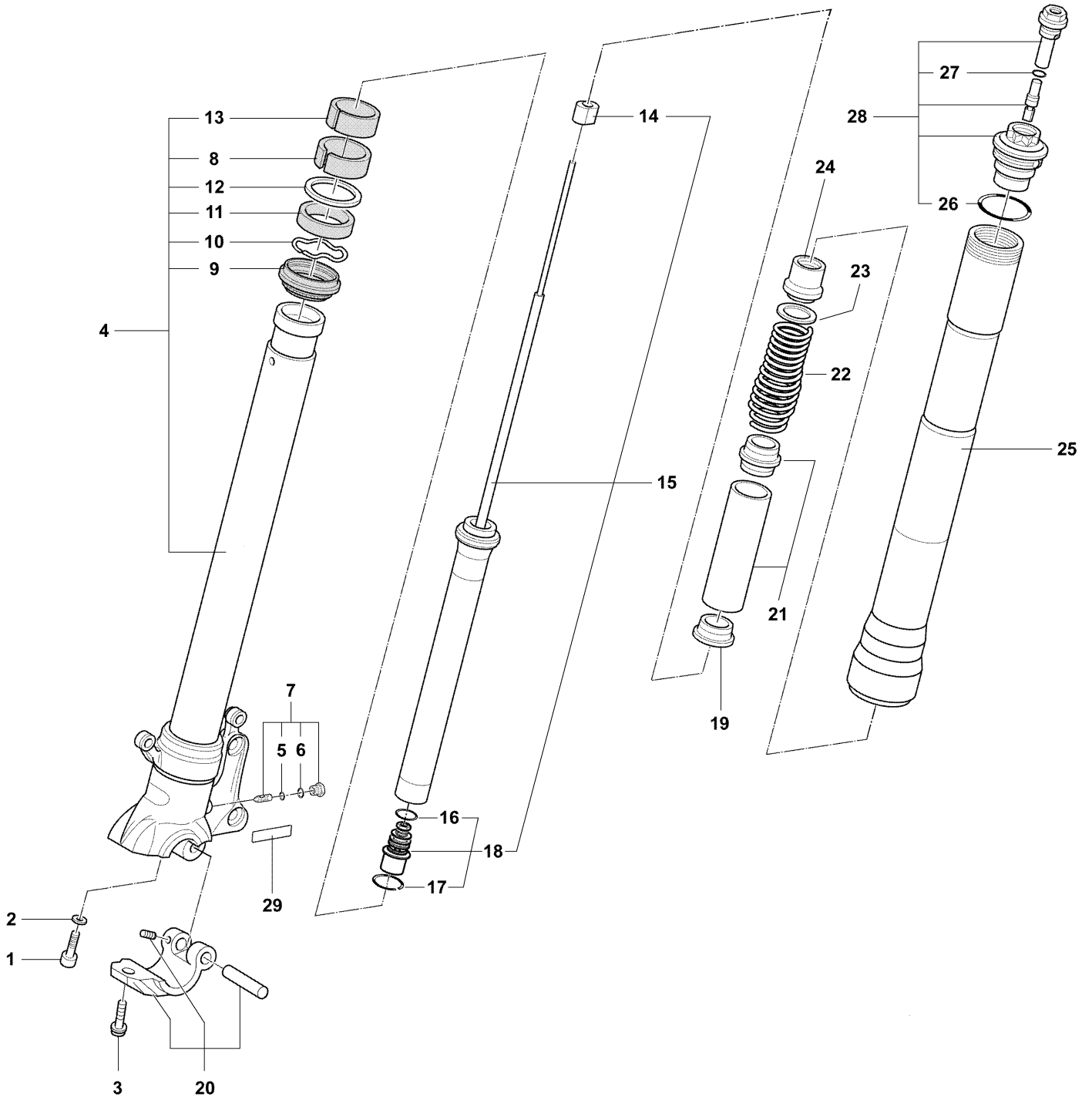

FORCELLA SINISTRA (F4 SPR / SENNA)

LEFT-HAND FORK (F4 SPR / SENNA) • FOURCHE GAUCHE (F4 SPR / SENNA)

LINKE GABEL (F4 SPR / SENNA) • HORQUILLA IZQUIERDA (F4 SPR / SENNA)



N.	Code	Q.ty	Note	750 S	750 S 1+1	SPR	SR-SR1+1	SENNA	► I FRAME I ►	► I ENGINE I ►
1	8000A0841	1				•				
1	8000A0841	1	❶					•	005464 I ►	
2	800031113	1				•				
2	800031113	1	❶					•	005464 I ►	
3	800082708	1				•				
3	800082708	1	❶					•	005464 I ►	
4	80A0A1857	1				•				
4	80A0A1857	1	❶					•	005464 I ►	
5	8000A0826	1				•				
5	8000A0826	1	❶					•	005464 I ►	
6	800050679	1				•				
6	800050679	1	❶					•	005464 I ►	
7	8000A1859	1				•				
7	8000A1859	1	❶					•	005464 I ►	
8	8000A1860	1				•				
8	8000A1860	1	❶					•	005464 I ►	
9	800086501	1				•				
9	800086501	1	❶					•	005464 I ►	
10	800089274	1				•				
10	800089274	1	❶					•	005464 I ►	
11	800086500	1				•				
11	800086500	1	❶					•	005464 I ►	
12	800089275	1				•				
12	800089275	1	❶					•	005464 I ►	
13	800086503	1				•				
13	800086503	1	❶					•	005464 I ►	
14	800081174	1				•				
14	800081174	1	❶					•	005464 I ►	
15	8000A2216	1				•				
15	8000A2216	1	❶					•	005464 I ►	
16	800019789	1				•				
16	800019789	1	❶					•	005464 I ►	
17	800081164	1				•				
17	800081164	1	❶					•	005464 I ►	
18	8000A2217	1				•				
18	8000A2217	1	❶					•	005464 I ►	
19	8000A1863	1				•				
19	8000A1863	1	❶					•	005464 I ►	
20	8000A1865	1				•				
20	8000A1865	1	❶					•	005464 I ►	
21	8000A2218	1				•				
21	8000A2218	1	❶					•	005464 I ►	
22	8000A2219	1				•				
22	8000A2219	1	❶					•	005464 I ►	
23	8000A1867	1				•				
23	8000A1867	1	❶					•	005464 I ►	
24	8000A1868	1				•				
24	8000A1868	1	❶					•	005464 I ►	
25	8000A1869	1				•				
25	8000A1869	1	❶					•	005464 I ►	
26	8000A1870	1				•				
26	8000A1870	1	❶					•	005464 I ►	
27	8000A0817	1				•				
27	8000A0817	1	❶					•	005464 I ►	
28	8000A1871	1				•				
28	8000A1871	1	❶					•	005464 I ►	
29	8000A1872	1				•				
29	8000A1872	1	❶					•	005464 I ►	

❶ Esclusi gli USA - USA excluded - Sauf les USA - Ausschließlich USA - Excluidos los USA

B07

1



ASSIEME AMMORTIZZATORE DI STERZO

STEERING DAMPER ASSEMBLY • ENSEMBLE AMORTISSEUR DE DIRECTION

BAUGRUPPE LENKUNGSDÄMPFER • CONJUNTO AMORTIGUADOR DE DIRECCIÓN

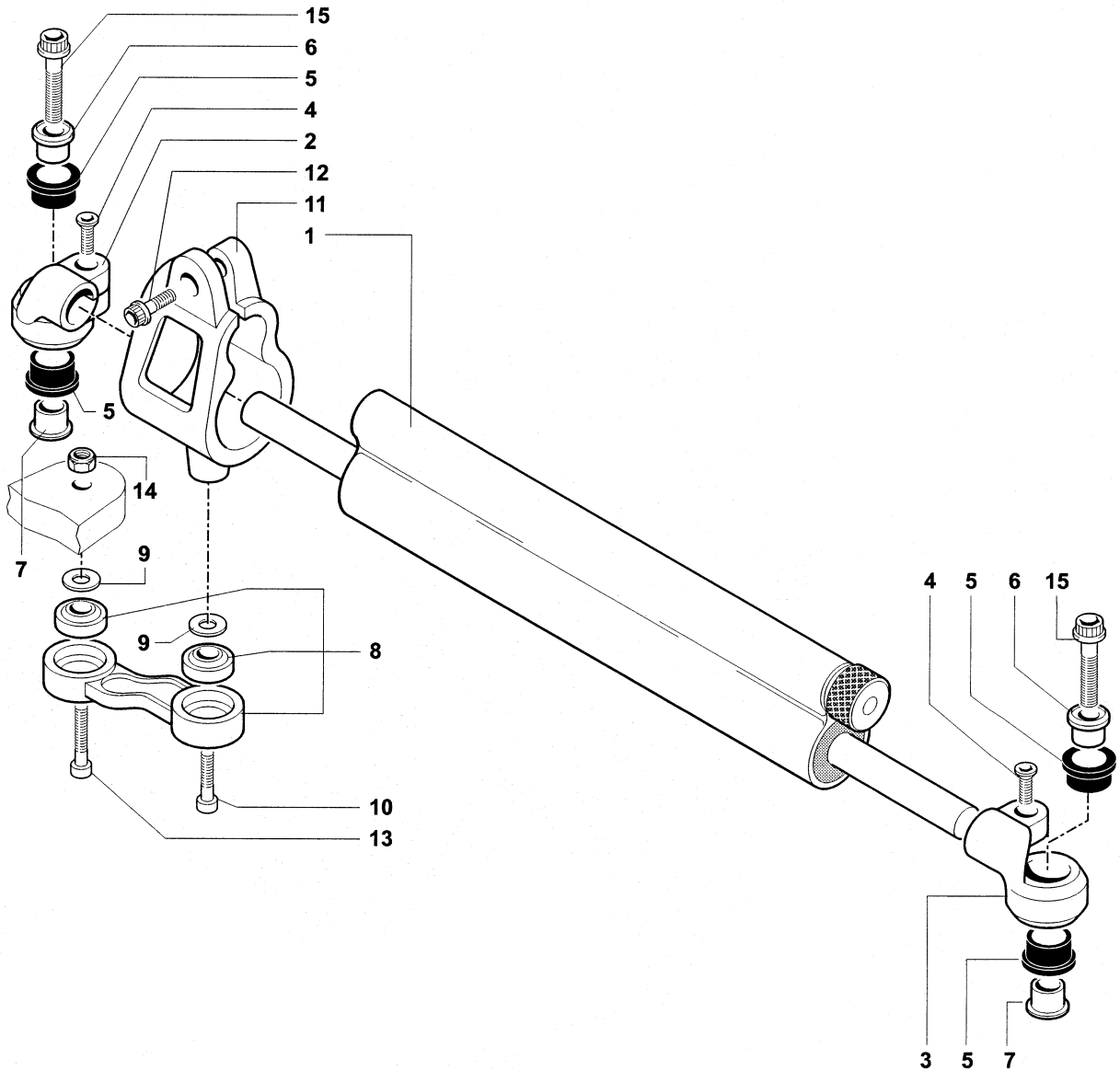

ASSIEME AMMORTIZZATORE DI STERZO

STEERING DAMPER ASSEMBLY • ENSEMBLE AMORTISSEUR DE DIRECTION

BAUGRUPPE LENKUNGSDÄMPFER • CONJUNTO AMORTIGUADOR DE DIRECCIÓN



N.	Code	Q.ty	Note	750 S	750 S 1+1	SPR	SR-SR1+1	SENNÁ	► I FRAME I ►	► I ENGINE I ►
1	800086406	1		•	•	•	•	•		
2	800082769	1		•	•	•	•	•		
3	800086408	1		•	•	•	•	•		
4	800089303	2		•	•	•	•	•		
5	800082776	4		•	•	•	•	•		
6	800089304	2		•	•	•	•	•		
7	800082775	2		•	•	•	•	•		
8	800090284	1		•	•	•	•	•		
9	800070163	2		•	•	•	•	•		
10	800089306	1		•	•	•	•	•		
11	800086409	1		•	•	•	•	•		
12	8E0090425	1		•	•	•	•	•		
13	8A0089306	1		•	•	•	•	•		
14	800090907	1		•	•	•	•	•		
15	8J0090425	2		•	•	•	•	•		



ASSIEME RUOTA POSTERIORE

REAR WHEEL ASSEMBLY • ENSEMBLE ROUE ARRIÈRE
BAUGRUPPE HINTERRAD • CONJUNTO RUEDA TRASERA

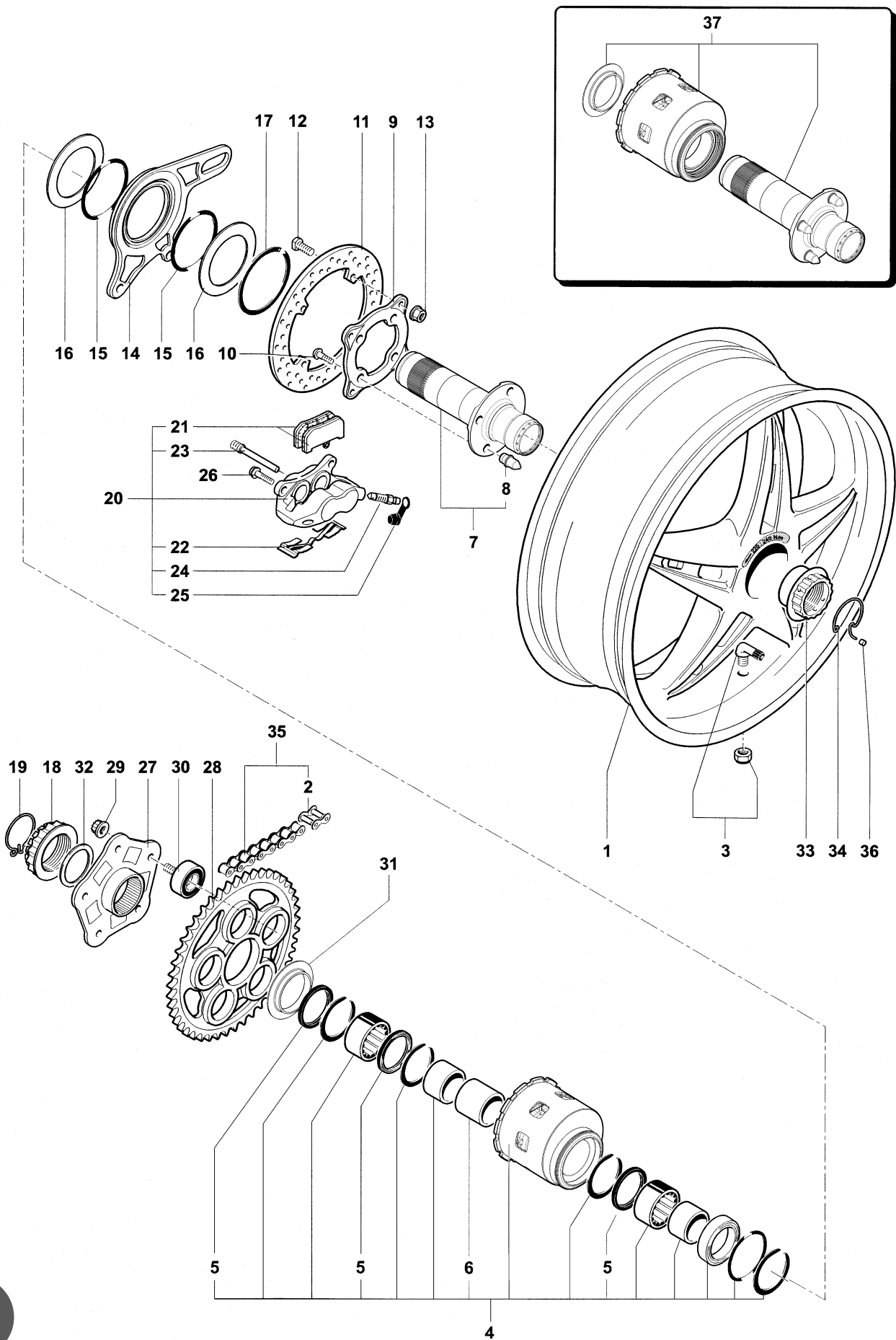

ASSIEME RUOTA POSTERIORE

 REAR WHEEL ASSEMBLY • ENSEMBLE ROUE ARRIÈRE
 BAUGRUPPE HINTERRAD • CONJUNTO RUEDA TRASERA

N.	Code	Q.ty	Note	750 S	750 S 1+1	SPR	SR-SR1+1	SENNÀ	► FRAME ►	► ENGINE ►
1	8AA090983	1	EV 02	•	•					
1	8AB090983	1	EV 03 / Euro 2	•	•					
1	8AB090983	1				•	•			
1	8AC090983	1						•		
2	800093864	1		•	•					
2	8000A3081	1				•	•	•		
3	800091011	1		•	•	•	•	•		
4	8000B2143	1	❶	•	•	•	•	•		
5	800084909	3	❶	•	•	•	•	•		
6	8000B2149	1	❶	•	•	•	•	•		
7	8000B3392	1	❶	•	•	•	•	•		
8	80A084901	4	❶	•	•	•	•	•		
9	800084890	1		•	•	•	•	•		
10	800084902	4		•	•	•	•	•		
11	800082760	1		•	•	•	•	•		
12	800084889	4		•	•	•	•	•		
13	800084891	4		•	•	•	•	•		
14	8000A3551	1		•	•	•	•	•		
15	800086702	2		•	•	•	•	•		
16	800084893	2		•	•	•	•	•		
17	800084913	1		•	•	•	•	•		
18	800084904	1		•	•	•	•	•		
19	800084898	1		•	•	•	•	•		
20	800082753	1		•	•	•	•	•		
21	800082748	1		•	•	•	•	•		
22	800082746	1		•	•	•	•	•		
23	800082743	1		•	•	•	•	•		
24	800089484	1		•	•	•	•	•		
25	800089491	1		•	•	•	•	•		
26	8E0090426	2		•	•	•	•	•		
27	800078219	1		•	•	•	•	•		
28	8A0084926	1	Z = 40	•	•					
28	8A0084924	1	Z = 38			•		•		
28	800084924	1	Z = 37			•		•		
28	8B0084924	1	Z = 39			•		•		
28	8AA084924	1	Z = 38				•			
29	800084952	5		•	•	•	•	•		
30	800078224	5		•	•	•	•	•		
31	8000B4955	1	❶	•	•	•	•	•		
32	800084894	1		•	•	•	•	•		
33	800084903	1		•	•	•	•	•		
34	800084899	1		•	•	•	•	•		
35	800091682	1		•	•					
35	8A00A3080	1				•	•	•		
36	800094030	1		•	•	•	•	•		
37	8000B4954	1	❷	•	•	•	•	•		

- ❶ Dopo la sostituzione del part. N° 37 - After replacement of part No. 37 - Suite à le remplacement du pièce N° 37 - Nach Wechsel von Teil Nr. 37 - Después de la sustitución de la pieza N° 37.
- ❷ Kit perno/mozzo/distanziale - Rear pin/hub/spacer kit - Kit axe/moyeu/entretoise - Bausatz Welle/Nabe/Abstandhalter - Kit perno/cubo/distanciador.



ASSIEME RUOTA ANTERIORE
FRONT WHEEL ASSEMBLY • ENSEMBLE ROUE AVANT
BAUGRUPPE VORDERRAD • CONJUNTO RUEDA DELANTERA

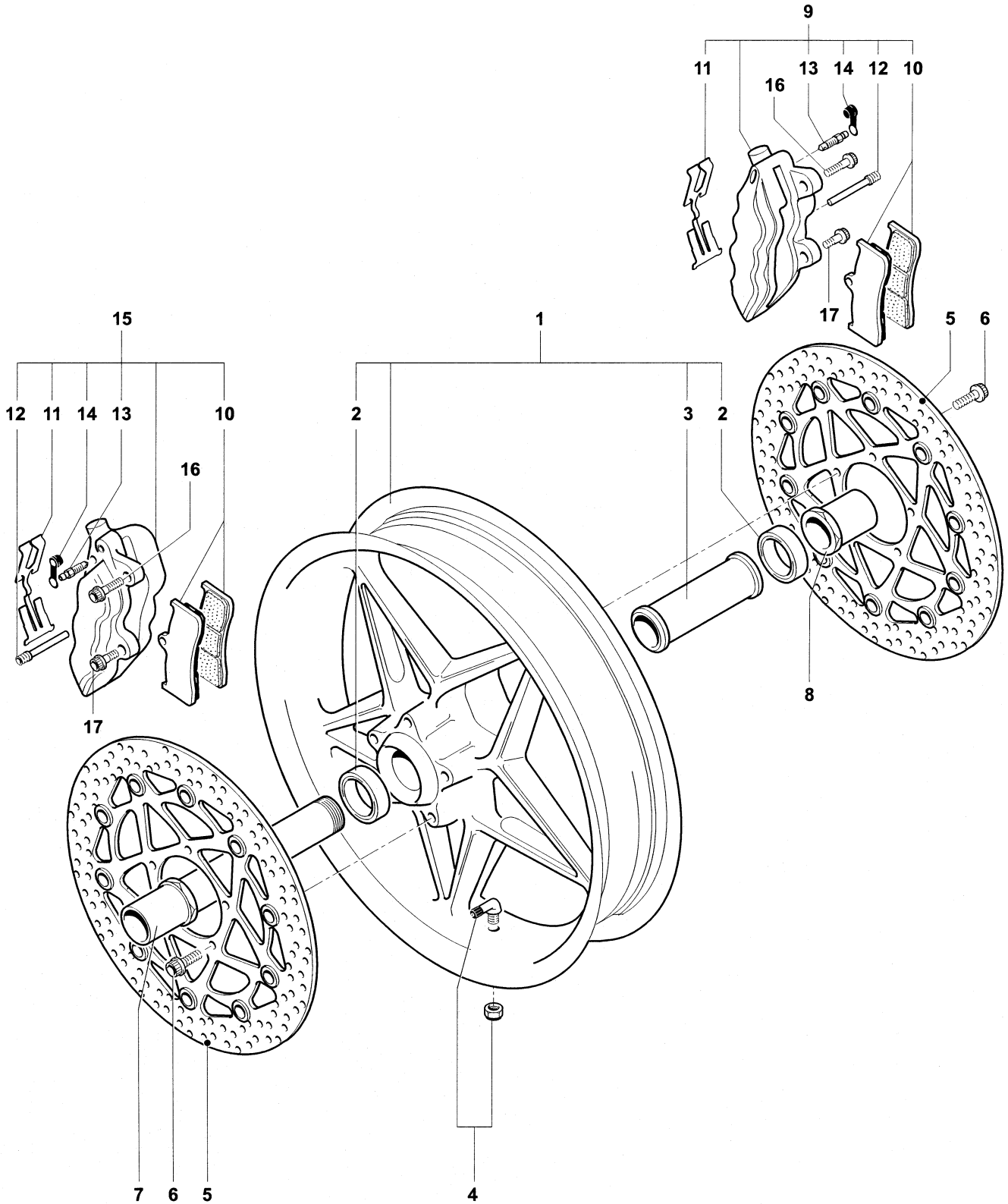

ASSIEME RUOTA ANTERIORE

 FRONT WHEEL ASSEMBLY • ENSEMBLE ROUE AVANT
 BAUGRUPPE VORDERRAD • CONJUNTO RUEDA DELANTERA

N.	Code	Q.ty	Note	750 S	750 S 1+1	SPR	SR-SR1+1	SENNÀ	► I FRAME I ►	► I ENGINE I ►
1	800094632	1	EV 02	•	•					
1	80A094632	1	EV 03 / Euro 2	•	•					
1	80A094632	1				•	•			
1	80B094632	1						•		
2	800090355	2		•	•	•	•	•		
3	800090356	1		•	•	•	•	•		
4	800091011	1		•	•	•	•	•		
5	800082759	2	≠ 4.0 mm	•	•		•			
5	8A0082759	2	≠ 4.8 mm	•	•		•			
5	800082758	2				•		•		
6	8C0090426	10		•	•	•	•	•		
7	800082752	1		•	•	•	•	•		
8	800082750	1		•	•	•	•	•		
9	800094023	1		•	•	•	•	•		
10	800094024	2		•	•	•	•	•		
11	800092886	2		•	•	•	•	•		
12	800082743	2		•	•	•	•	•		
13	800089484	2		•	•	•	•	•		
14	800089491	2		•	•	•	•	•		
15	800094022	1		•	•	•	•	•		
16	8L0082751	2		•	•	•	•	•		
17	8H0082751	2		•	•	•	•	•		



ASSIEME PEDANA SINISTRA

LEFT-HAND FOOTREST ASSEMBLY • ENSEMBLE REPOSE-PIEDS GAUCHE
BAUGRUPPE LINKES FUSSBRETT • CONJUNTO ESTRIBO IZQUIERDO

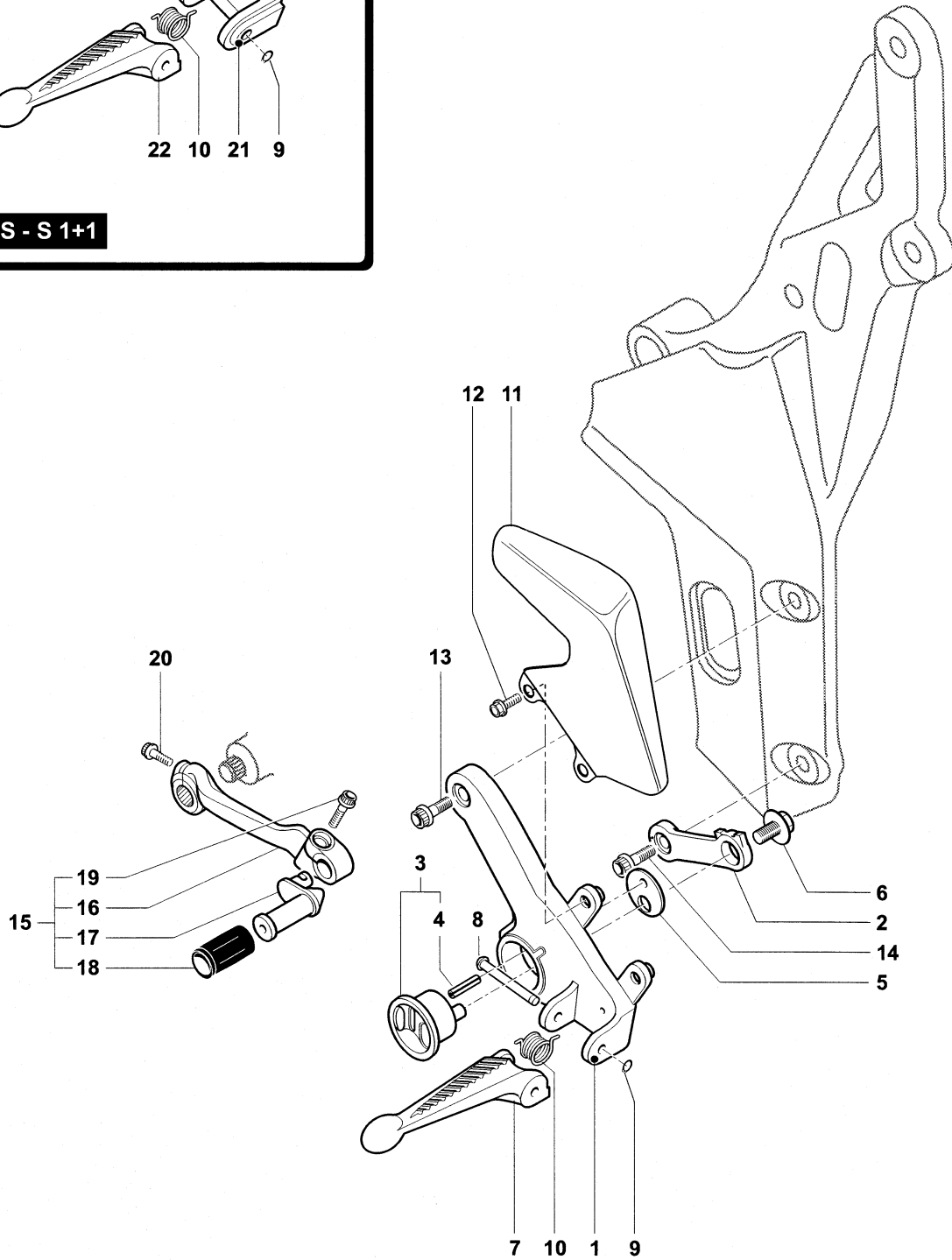
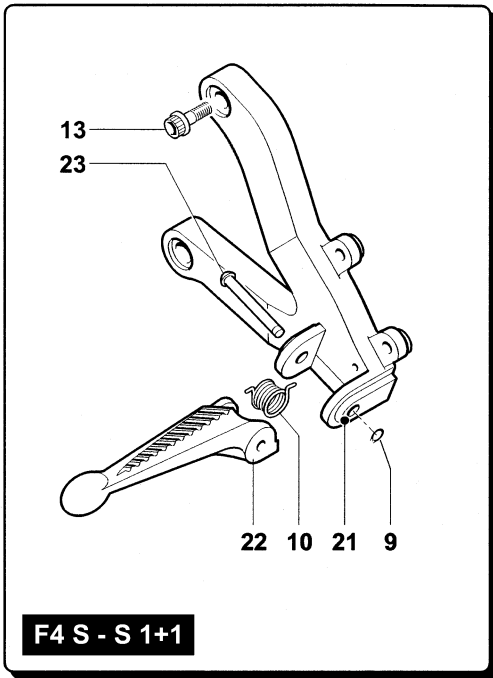

ASSIEME PEDANA SINISTRA

 LEFT-HAND FOOTREST ASSEMBLY • ENSEMBLE REPOSE-PIEDS GAUCHE
 BAUGRUPPE LINKES FUSSBRETT • CONJUNTO ESTRIBO IZQUIERDO

N.	Code	Q.ty	Note	750 S	750 S 1+1	SPR	SR-SR1+1	SENNÄ	► I FRAME I ►	► I ENGINE I ►
1	800089771	1				•		•		
2	800089773	1				•		•		
3	800092891	1				•		•		
4	800090314	1				•		•		
5	800089777	1				•		•		
6	800089778	1				•		•		
7	800087465	1				•		•		
8	800090416	1				•		•		
9	800090429	1		•	•	•	•	•		
10	800090418	1		•	•	•	•	•		
11	800089335	1		•	•	•	•	•		
12	800062725	2		•	•	•	•	•		
13	8G0090426	1		•	•	•	•	•		
14	8F0090426	1				•		•		
15	800090277	1		•	•	•	•	•		
16	800089759	1		•	•	•	•	•		
17	800089760	1		•	•	•	•	•		
18	800089298	1		•	•	•	•	•		
19	8G0090425	1		•	•	•	•	•		
20	8G0090425	1		•	•	•	•	•		
21	80A091659	1		•	•	•	•	•		
22	80A091661	1		•	•	•	•	•		
23	80A053546	1		•	•	•	•	•		



ASSIEME PEDANA DESTRA

RIGHT-HAND FOOTREST ASSEMBLY • ENSEMBLE REPOSE-PIEDS DROIT
BAUGRUPPE RECHTES FUSSBRETT • CONJUNTO ESTRIBO DERECHO

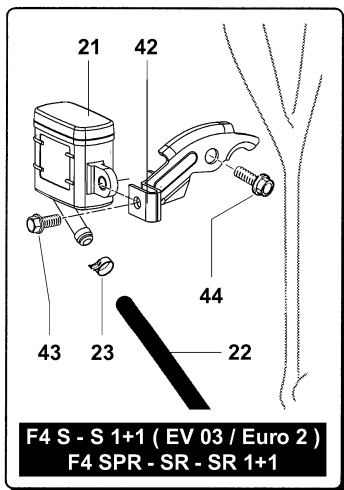
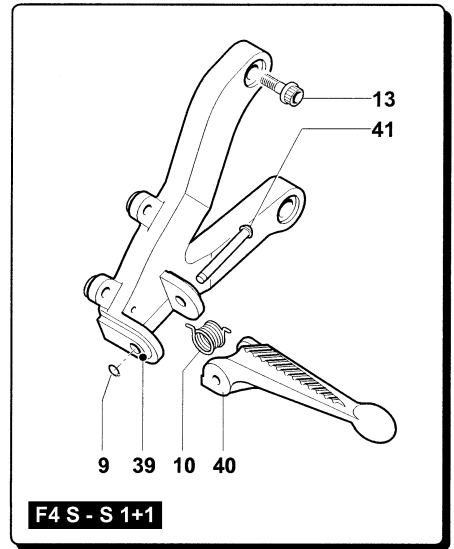
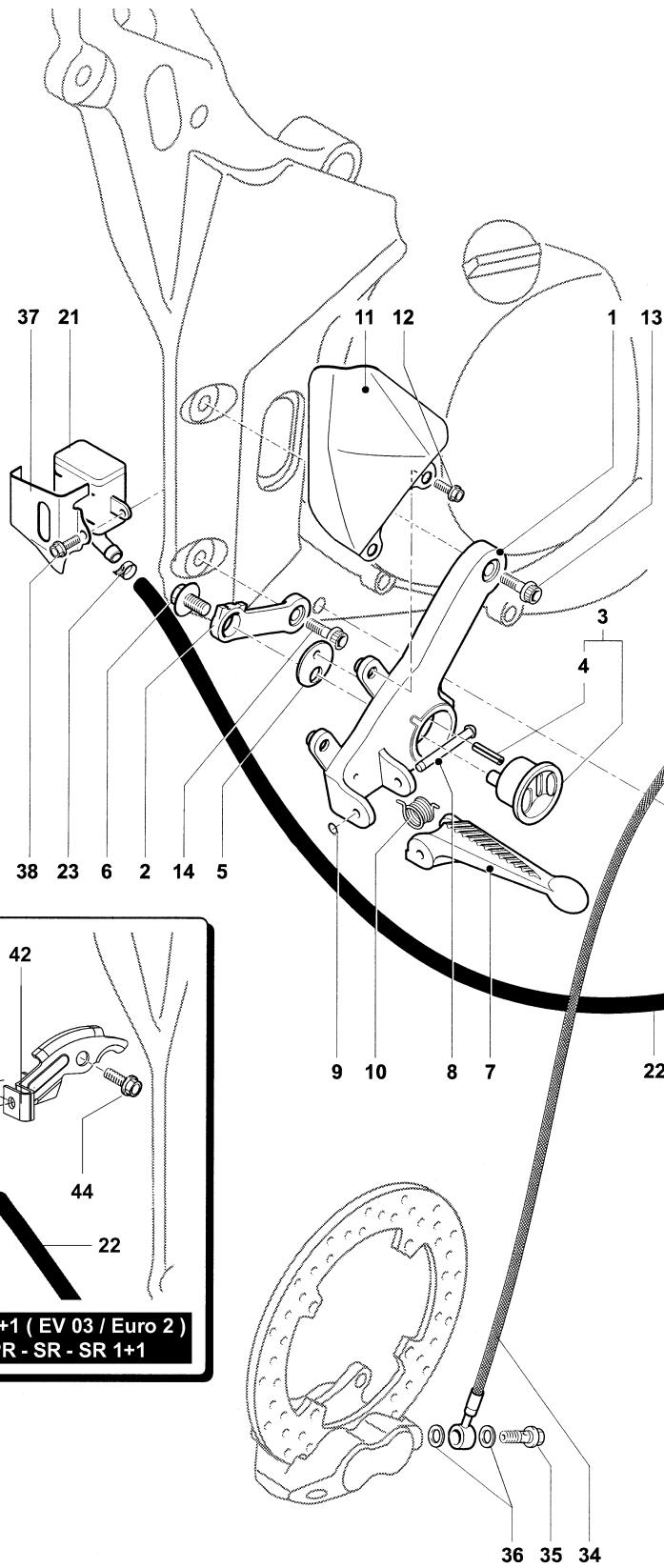

ASSIEME PEDANA DESTRA

 RIGHT-HAND FOOTREST ASSEMBLY • ENSEMBLE REPOSE-PIEDS DROIT
 BAUGRUPPE RECHTES FUSSBRETT • CONJUNTO ESTRIBO DERECHO



N.	Code	Q.ty	Note	750 S	750 S 1+1	SPR	SR-SR1+1	SENNÀ	► I FRAME I ◄	► I ENGINE I ◄
1	800089772	1				•		•		
2	800089774	1				•		•		
3	800092890	1				•		•		
4	800090314	1				•		•		
5	800089777	1				•		•		
6	800089778	1				•		•		
7	800087466	1				•		•		
8	800090416	1				•		•		
9	800090429	1		•	•	•	•	•		
10	800090418	1		•	•	•	•	•		
11	800089334	1		•	•	•	•	•		
12	800062725	2		•	•	•	•	•		
13	8G0090426	2		•	•		•			
13	8G0090426	1				•		•		
14	8F0090426	1		•	•	•	•	•		
15	800090275	1		•	•	•	•	•		
16	800093314	1		•	•	•	•	•		
17	800089760	1		•	•	•	•	•		
18	800089298	1		•	•	•	•	•		
19	8G0090425	1		•	•	•	•	•		
20	800089313	1		•	•	•	•	•		
21	800090315	1		•	•	•	•	•		
22	8A0070266	1	EV 02	•	•					
22	8G0070266	1	EV 03 / Euro 2	•	•					
22	8G0070266	1				•	•			
22	8A0070266	1						•		
23	800070700	2		•	•	•	•	•		
24	8F0090426	1		•	•	•	•	•		
25	80A055757	1		•	•	•	•	•		
26	61N115062	1		•	•	•	•	•		
27	80A053548	1		•	•	•	•	•		
28	800090894	1		•	•	•	•	•		
29	800001199	2		•	•	•	•	•		
30	800089770	1		•	•	•	•	•		
31	800090312	1		•	•	•	•	•		
32	800062728	1		•	•	•	•	•		
33	8A0067545	1		•	•	•	•	•		
34	800090313	1		•	•	•	•	•		
35	800091692	2		•	•	•	•	•		
36	800021480	4		•	•	•	•	•		
37	800092660	1	EV 02	•	•					
37	800092660	1						•		
38	800062727	1	EV 02	•	•					
38	800062727	1						•		
39	80A091660	1		•	•		•			
40	80A091662	1		•	•		•			
41	80A053546	1		•	•		•			
42	800099341	1	EV 03 / Euro 2	•	•					
42	800099341	1				•	•			
43	800062726	1	EV 03 / Euro 2	•	•					
43	800062726	1				•	•			
44	8B0069056	1	EV 03 / Euro 2	•	•					
44	8B0069056	1				•	•			



ASSIEME SEMIMANUBRIO DESTRO

RIGHT-HAND HANDLEBAR ASSEMBLY • ENSEMBLE GUIDON DROIT

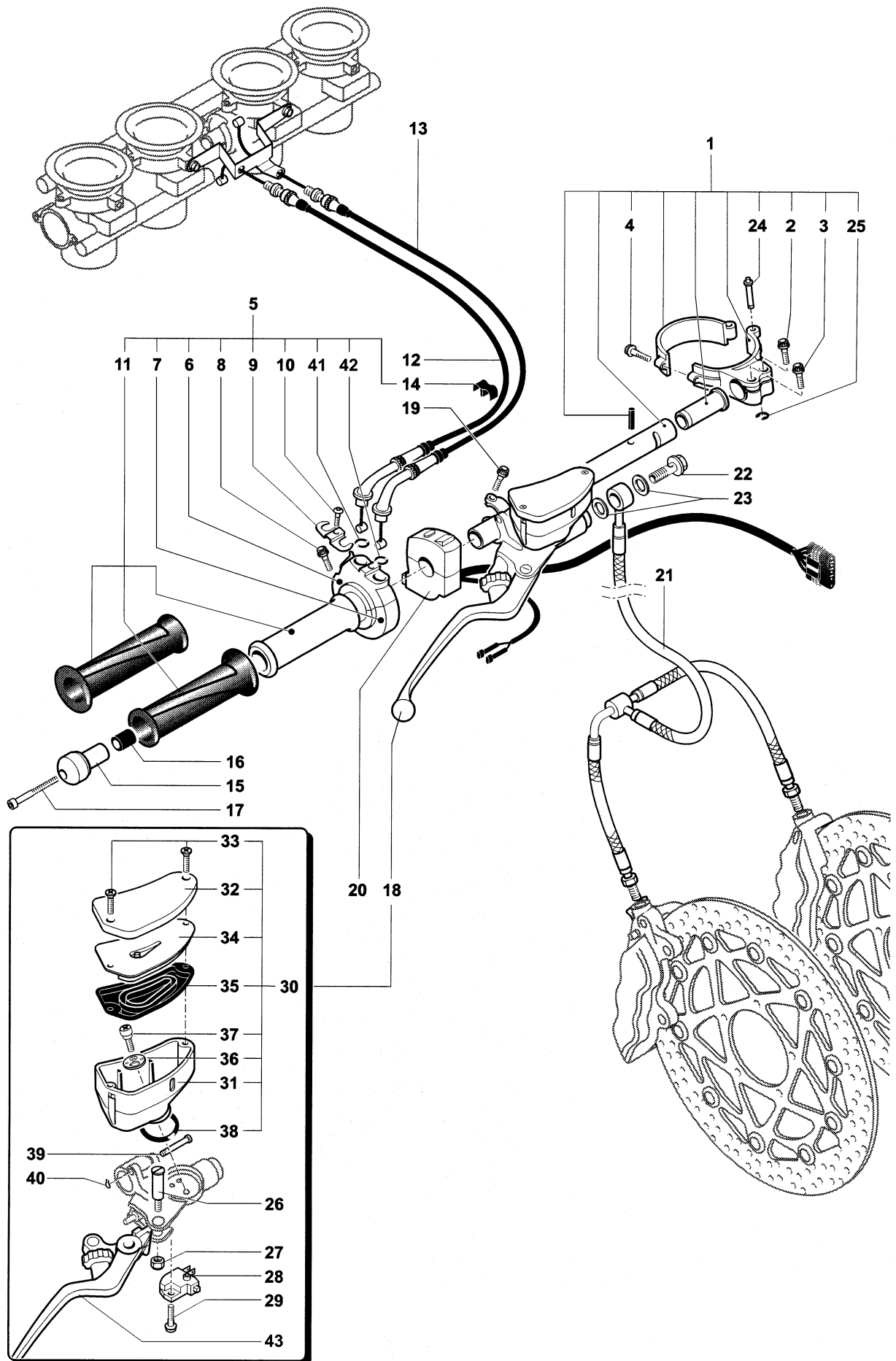
BAUGRUPPE RECHTE LENKERHÄLFTE • CONJUNTO SEMIMANILLAR DERECHO



ASSIEME SEMIMANUBRIO DESTRO

RIGHT-HAND HANDLEBAR ASSEMBLY • ENSEMBLE GUIDON DROIT

BAUGRUPPE RECHTE LENKERHÄLFTE • CONJUNTO SEMIMANILLAR DERECHO



N.	Code	Q.ty	Note	750 S	750 S 1+1	SPR	SR-SR1+1	SENNÀ	► I FRAME I ►	► I ENGINE I ►
1	800092892	1		•	•	•		•		
1	80A092892	1					•			
2	8J0090425	1		•	•	•	•	•		
3	8G0090425	1		•	•	•	•	•		
4	8J0090425	1		•	•	•	•	•		
5	800094640	1		•	•	•	•	•		
5	800099416	1	F	•	•	•	•	•		
6	800092894	1		•	•	•	•	•		
7	800090265	1		•	•	•	•	•		
7	800099413	1	F	•	•	•	•	•		
8	8H0090425	2		•	•	•	•	•		
9	800090266	1		•	•	•	•	•		
10	800093297	1		•	•	•	•	•		
11	800094529	1		•	•	•	•	•		
12	800090271	1		•	•	•	•	•		
13	800090272	1		•	•	•	•	•		
14	800092630	1		•	•	•	•	•		
15	800089782	1		•	•	•		•		
15	80A089782	1					•			
16	800090890	1		•	•	•	•	•		
17	60N102517	1		•	•	•	•	•		
18	800094025	1		•	•	•	•	•		
19	8H0090425	1		•	•	•	•	•		
20	800091533	1		•	•	•	•	•		
21	800087467	1		•	•	•	•	•		
22	800091692	1		•	•	•	•	•		
23	800021480	2		•	•	•	•	•		
24	800090891	1		•	•	•	•	•		
25	800090892	1		•	•	•	•	•		
26	800093299	1		•	•	•	•	•		
27	800093300	1		•	•	•	•	•		
28	800070864	1		•	•	•	•	•		
29	800070865	1		•	•	•	•	•		
30	800093301	1		•	•	•	•	•		
31	800082733	1		•	•	•	•	•		
32	800082728	1		•	•	•	•	•		
33	800093313	2		•	•	•	•	•		
34	800093302	1		•	•	•	•	•		
35	800093303	1		•	•	•	•	•		
36	800098962	1		•	•	•	•	•		
37	8000A1295	1		•	•	•	•	•		
38	800093306	1		•	•	•	•	•		
39	800082695	1		•	•	•	•	•		
40	800094643	1		•	•	•	•	•		
41	8000A2181	1		•	•	•	•	•		
42	8000A2180	1		•	•	•	•	•		
43	8000A3823	1		•	•	•	•	•		



ASSIEME SEMIMANUBRIO SINISTRO

LEFT-HAND HANDLEBAR ASSEMBLY • ENSEMBLE GUIDON GAUCHE

BAUGRUPPE LINKE LENKERHÄLFTE • CONJUNTO SEMIMANILLAR IZQUIERDO

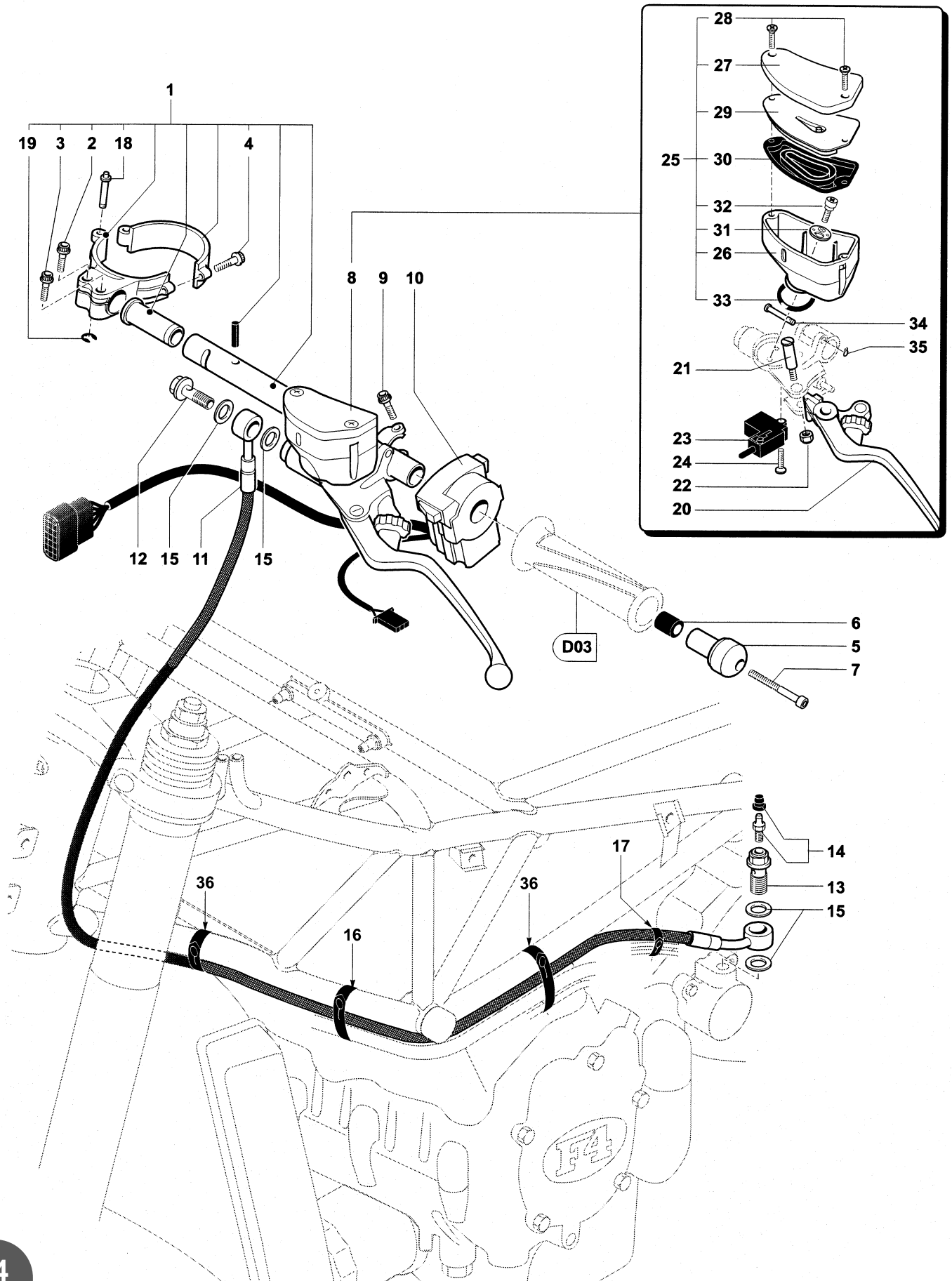

ASSIEME SEMIMANUBRIO SINISTRO

LEFT-HAND HANDLEBAR ASSEMBLY • ENSEMBLE GUIDON GAUCHE

BAUGRUPPE LINKE LENKERHÄLFTE • CONJUNTO SEMIMANILLAR IZQUIERDO



N.	Code	Q.ty	Note	750 S	750 S 1+1	SPR	SR-SR1+1	SENNÀ	► I FRAME I ►	► I ENGINE I ►
1	800092893	1		•	•	•		•		
1	80A092893	1					•			
2	8J0090425	1		•	•	•	•	•		
3	8G0090425	1		•	•	•	•	•		
4	8J0090425	1		•	•	•	•	•		
5	800089782	1		•	•	•		•		
5	80A089782	1					•			
6	800090890	1		•	•	•	•	•		
7	60N102517	1		•	•	•	•	•		
8	800089312	1		•	•	•	•	•		
9	8H0090425	1		•	•	•	•	•		
10	800091534	1	① EV 02	•	•					
10	800096455	1	EV 03 / Euro 2	•	•					
10	800096455	1	USA JPN	•	•					
10	800096455	1				•	•			
10	800091534	1	①					•		
11	800087468	1		•	•	•	•	•		
12	800091692	1		•	•	•	•	•		
13	800091691	1		•	•	•	•	•		
14	800033552	1		•	•	•	•	•		
15	800021480	4		•	•	•	•	•		
16	800092248	1		•	•	•	•	•		
17	800092668	1		•	•	•	•	•		
18	800090891	1		•	•	•	•	•		
19	800090892	1		•	•	•	•	•		
20	800093298	1		•	•	•	•	•		
21	800093299	1		•	•	•	•	•		
22	800093300	1		•	•	•	•	•		
23	800093307	1		•	•	•	•	•		
24	800093313	1		•	•	•	•	•		
25	800093308	1		•	•	•	•	•		
26	800093309	1		•	•	•	•	•		
27	800093310	1		•	•	•	•	•		
28	800093313	2		•	•	•	•	•		
29	800093311	1		•	•	•	•	•		
30	800093312	1		•	•	•	•	•		
31	800098962	1		•	•	•	•	•		
32	8000A1295	1		•	•	•	•	•		
33	800093306	1		•	•	•	•	•		
34	800082695	1		•	•	•	•	•		
35	800094643	1		•	•	•	•	•		
36	800092247	2		•	•	•	•	•		

① Su richiesta è possibile ordinare in alternativa il part. Cod. N° 800096455 (commutatore per luci sempre accese). - On request, it is possible to order the Code No. 800096455 part (switch for lights-on only) as an alternative. - A requete on commander la pièce No. 800096455 (comodo pour feux toujours allumé) en alternative. - Auf die Anfrage kann bestellen der Teil Nr. 800096455 (Wechselschalter für das Fahrlicht einschalten) in Alternative. - A solicitud es posible pedir la pieza N° 800096455 (conmutador para luces encendidas) en alternativa.



SERRATURE
LOCKS • VERROUILLAGES
SCHLÖSSER • CERRADURAS

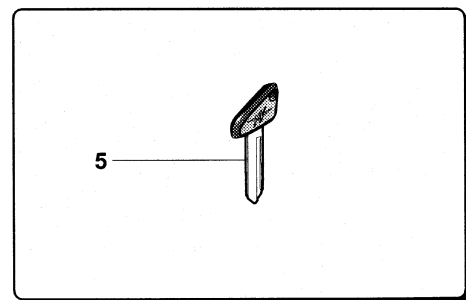
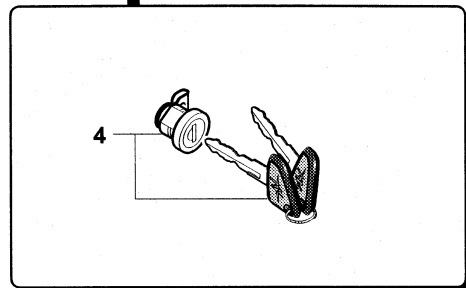
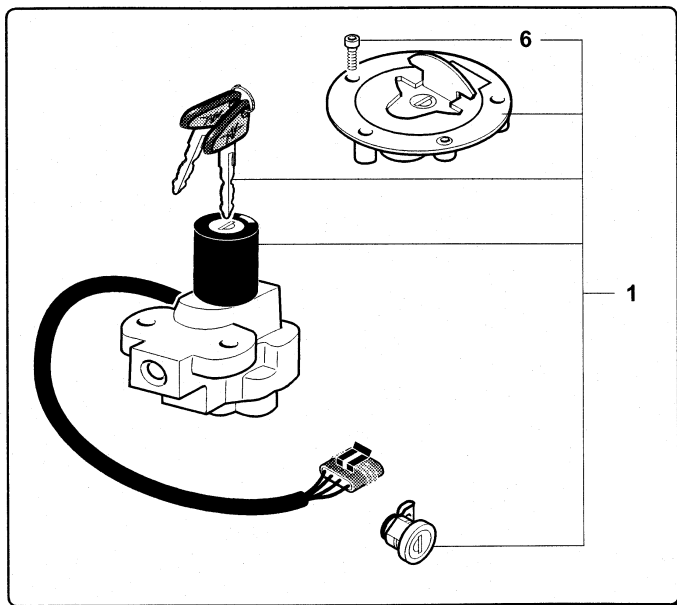
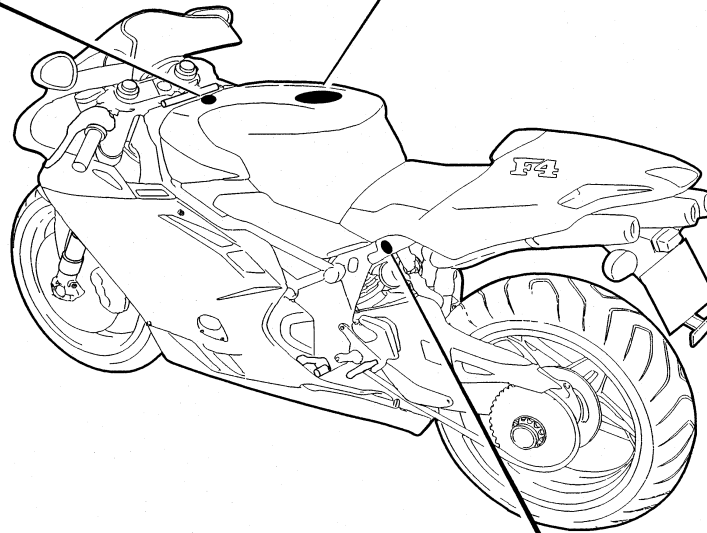
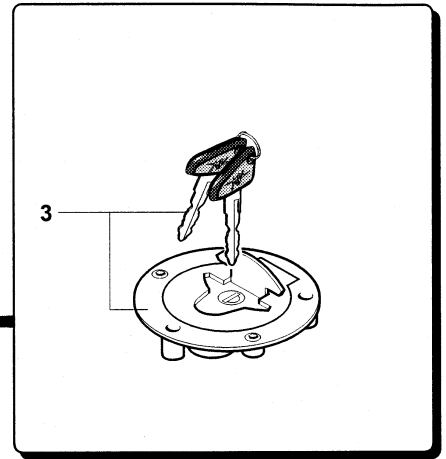
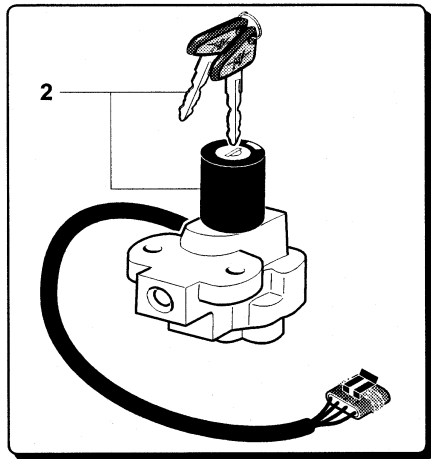

SERRATURELOCKS • VERROUILLAGES
SCHLÖSSER • CERRADURAS

N.	Code	Q.ty	Note	750 S	750 S 1+1	SPR	SR-SR1+1	SENNA	► I FRAME I ►	► I ENGINE I ►
1	800090249	1		•	•	•	•	•		
2	800093339	1		•	•	•	•	•		
3	800093340	1		•	•	•	•	•		
4	800093341	1		•	•	•	•	•		
5	800093338	1		•	•	•	•	•		
6	8A0066531	3		•	•	•	•	•		



ASSIEME CARENATURE

FAIRING ASSEMBLY • ENSEMBLE CARÉNAGE

BAUGRUPPE KAROSSERIE UND VERKLEIDUNG • CONJUNTO CARENADOS

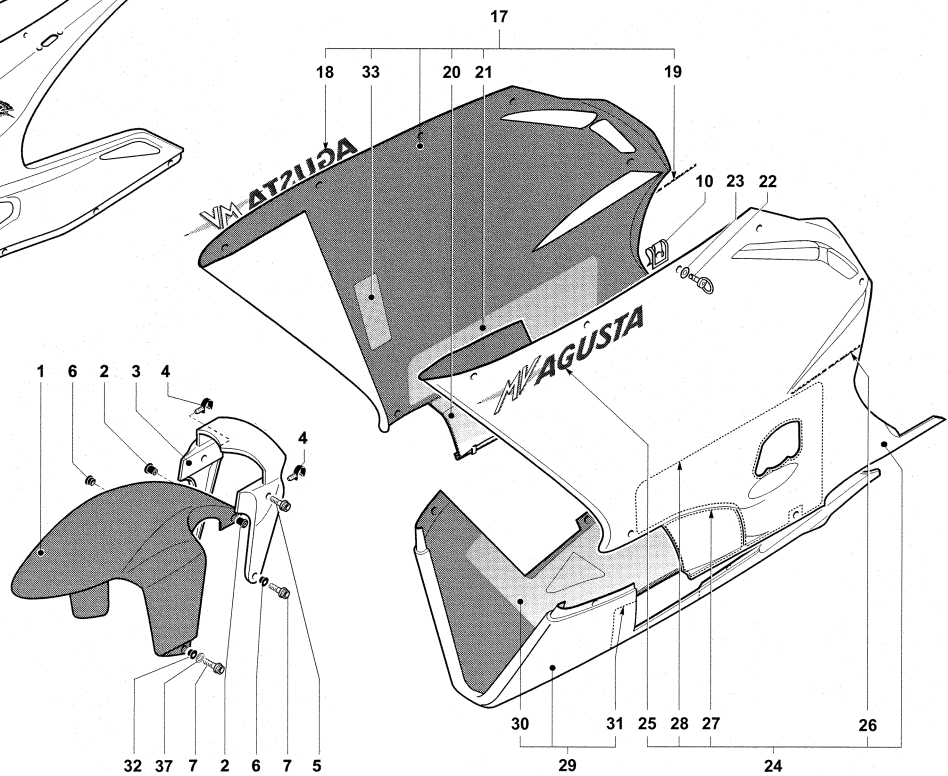
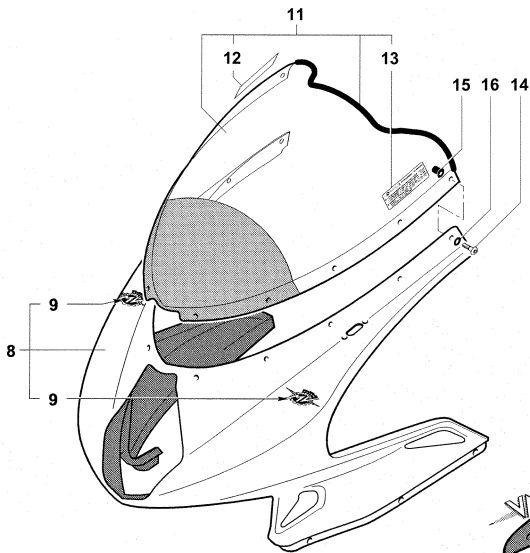
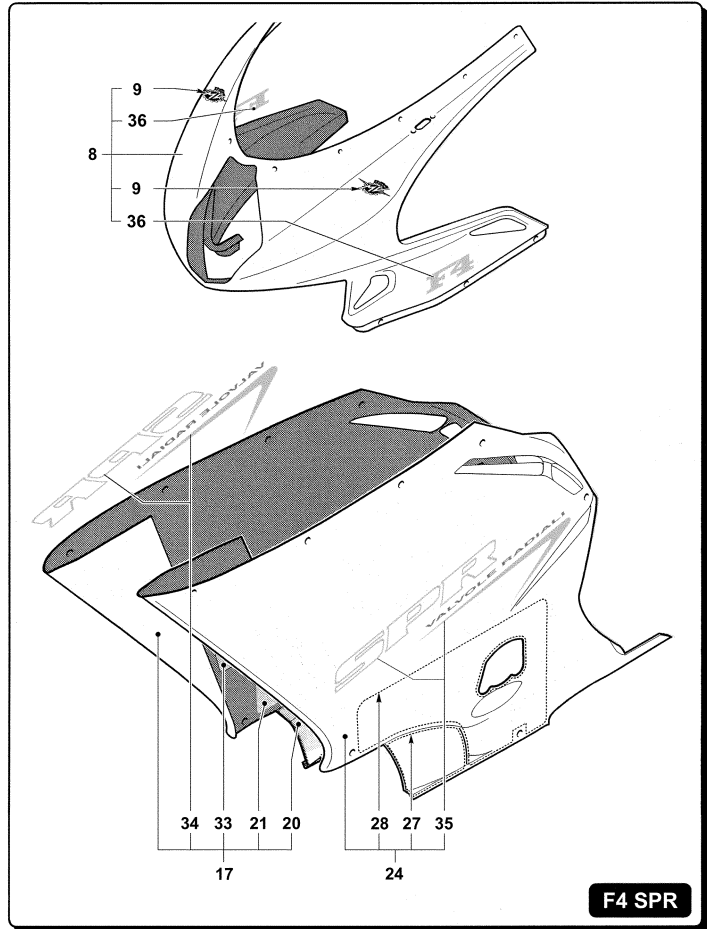
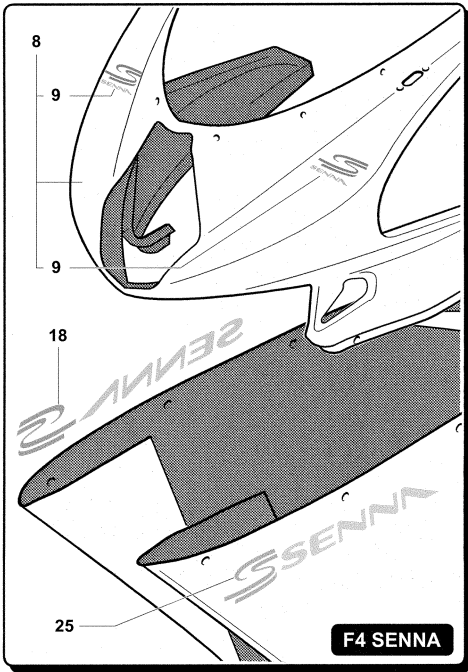

ASSIEME CARENATURE

FAIRING ASSEMBLY • ENSEMBLE CARÉNAGE

BAUGRUPPE KAROSSERIE UND VERKLEIDUNG • CONJUNTO CARENADOS



N.	Code	Q.ty	Note	750 S	750 S 1+1	SPR	SR-SR1+1	SENNÀ	► I FRAME I ►	► I ENGINE I ►
1	80A0A3055	1	A	.	.					
1	80D0A3055	1	B	.	.					
1	80E0A3055	1	C	.	.					
1	80B090254	1				.		.		
1	80A0A3055	1					.			
2	800048245	2			
3	800098328	1		.	.					
3	800090288	1				.	.	.		
4	800091005	2			
5	8M0090425	2			
6	800092670	2			
7	8D0090425	4			
8	800091667	1	A	.	.					
8	80A091667	1	B	.	.					
8	80B091667	1	C	.	.					
8	8000A2400	1				.				
8	800091667	1					.			
8	800099165	1						.		
9	800090316	2				
9	800099167	2						.		
10	800090427	13			
11	8000A9983	1			
11	8000A9987	1	USA		
12	80A0A4000	1	1		
13	800092666	1			
13	800094020	1	USA		
14	8A0090901	10			
15	800091022	10			
16	800092882	10			
17	800091668	1	A	.	.					
17	80A091668	1	B	.	.					
17	80B091668	1	C	.	.					
17	8000A2398	1				.				
17	800091668	1					.			
17	800098982	1						.		
18	800090318	1	A B	.	.					
18	80A090318	1	C	.	.					
18	80A090318	1				.				
18	800090318	1					.			
18	800098980	1						.		
19	800090319	1	A B	.	.					
19	80A090319	1	C	.	.					
19	80A090319	1				.		.		
19	800090319	1					.			
20	800092261	1			
21	800092262	1			
22	800089750	17			
23	800089751	17			
24	800091669	1	A	.	.					
24	80A091669	1	B	.	.					
24	80B091669	1	C	.	.					
24	8000A2399	1				.				
24	800091669	1					.			
24	800098981	1						.		

A Versione Rosso/Argento - Red/Silver version - Version Rouge/Argent - Rot/Silber Version - Versión Rojo/Plata.

B Versione Argento - Silver version - Version Argent - Silber Version - Versión Plata.

C Versione Nera - Black version - Version Noire - Schwarze Version - Versión Negra.

1 Esclusi gli USA - USA excluded - Sauf les USA - Ausschließlich USA - Excluidos los USA

E01

5



ASSIEME CARENATURE

FAIRING ASSEMBLY • ENSEMBLE CARÉNAGE

BAUGRUPPE KAROSSERIE UND VERKLEIDUNG • CONJUNTO CARENADOS

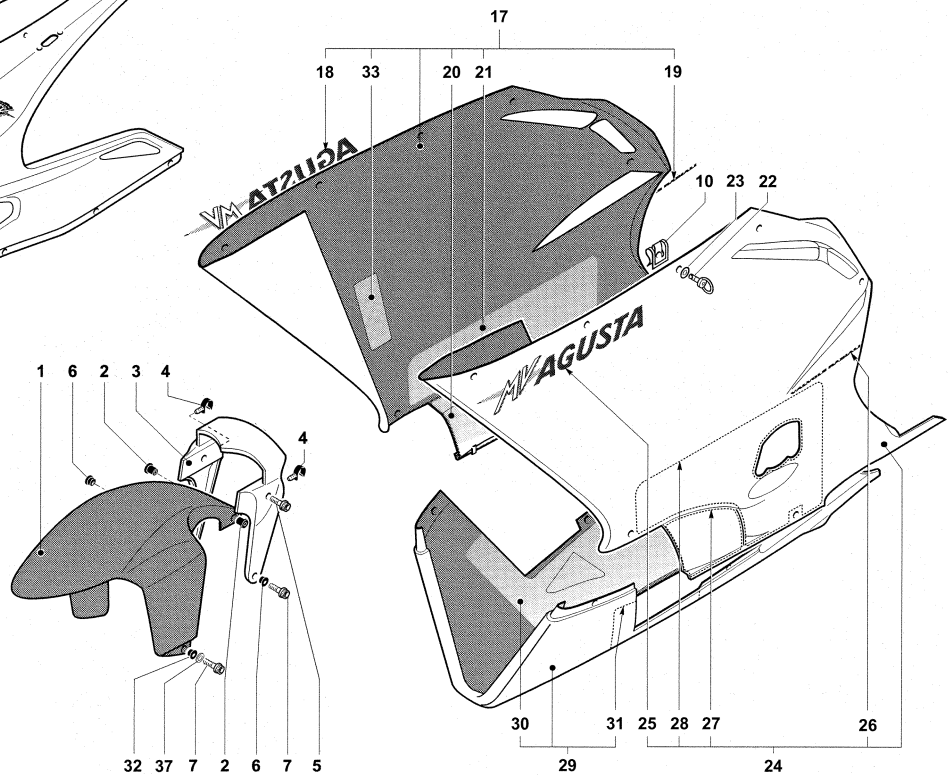
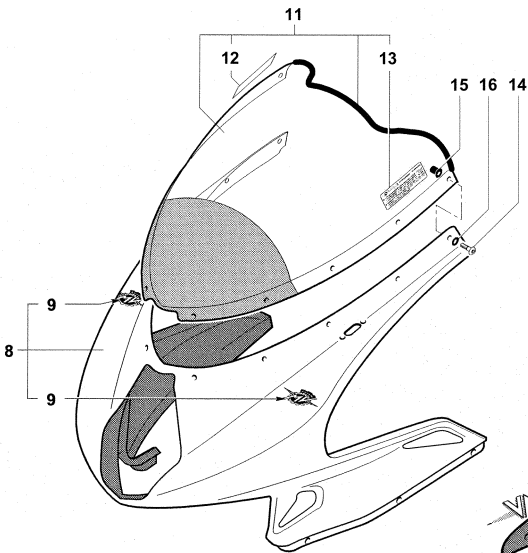
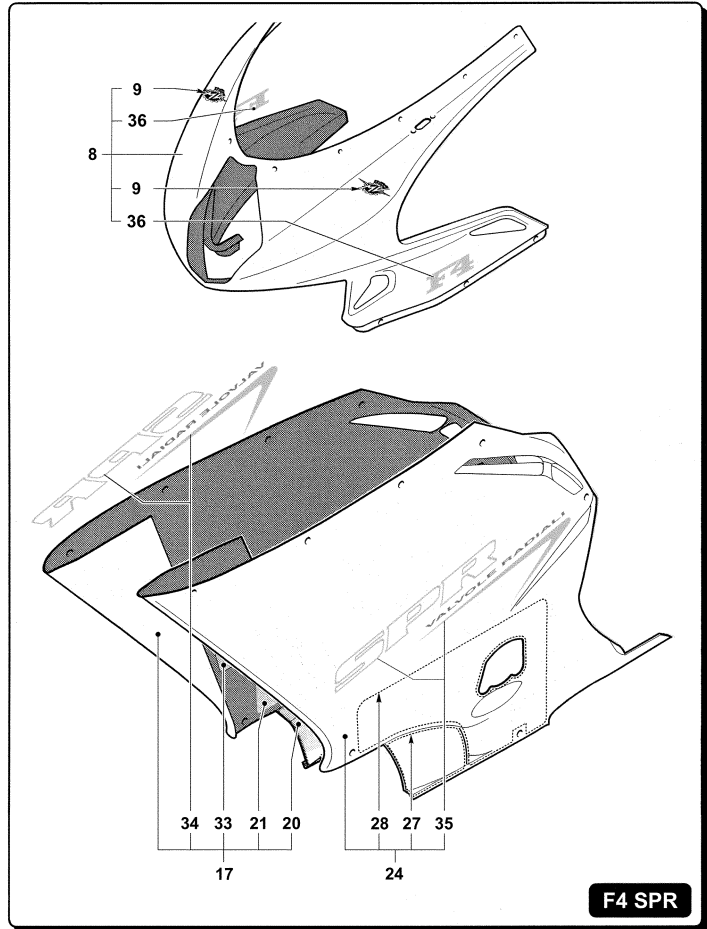
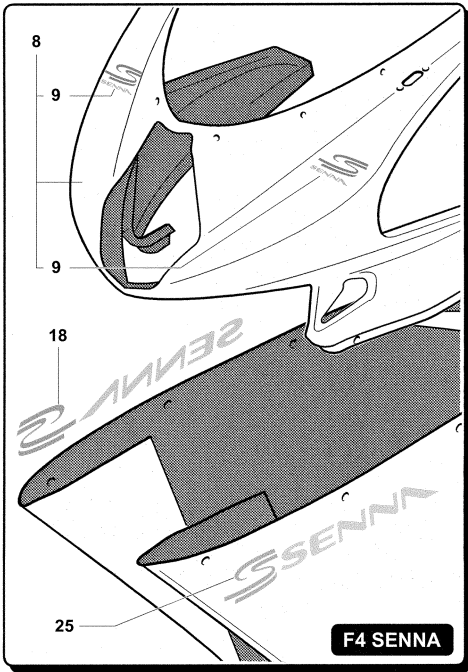

ASSIEME CARENATURE

FAIRING ASSEMBLY • ENSEMBLE CARÉNAGE

BAUGRUPPE KAROSSERIE UND VERKLEIDUNG • CONJUNTO CARENADOS



N.	Code	Q.ty	Note	750 S	750 S 1+1	SPR	SR-SR1+1	SENNA	► FRAME ►	► ENGINE ►
25	800090317	1	A B	.	.					
25	80A090317	1	C	.	.					
25	80A090317	1				.				
25	800090317	1					.			
25	800098979	1						.		
26	800090319	1	A B	.	.					
26	80A090319	1	C	.	.					
26	80A090319	1				.		.		
26	800090319	1					.			
27	800092263	1			
28	800092264	1			
29	800092272	1	A	.	.					
29	80A092272	1	B	.	.					
29	80B092272	1	C	.	.					
29	80B092272	1				.				
29	800092272	1					.			
29	80C092272	1						.		
30	800092266	1			
31	800092265	1			
32	800092670	2			
33	800097895	1			
34	8000A2392	1				.				
35	8000A2393	1				.				
36	8000A2397	2				.				
37	800062738	2				.		.		



- A** Versione Rosso/Argento - Red/Silver version - Version Rouge/Argent - Rot/Silber Version - Versión Rojo/Plata.
- B** Versione Argento - Silver version - Version Argent - Silber Version - Versión Plata.
- C** Versione Nera - Black version - Version Noire - Schwarze Version - Versión Negra.



ASSIEME AIRBOX

AIRBOX ASSEMBLY • ENSEMBLE AIRBOX
BAUGRUPPE AIRBOX • CONJUNTO AIRBOX

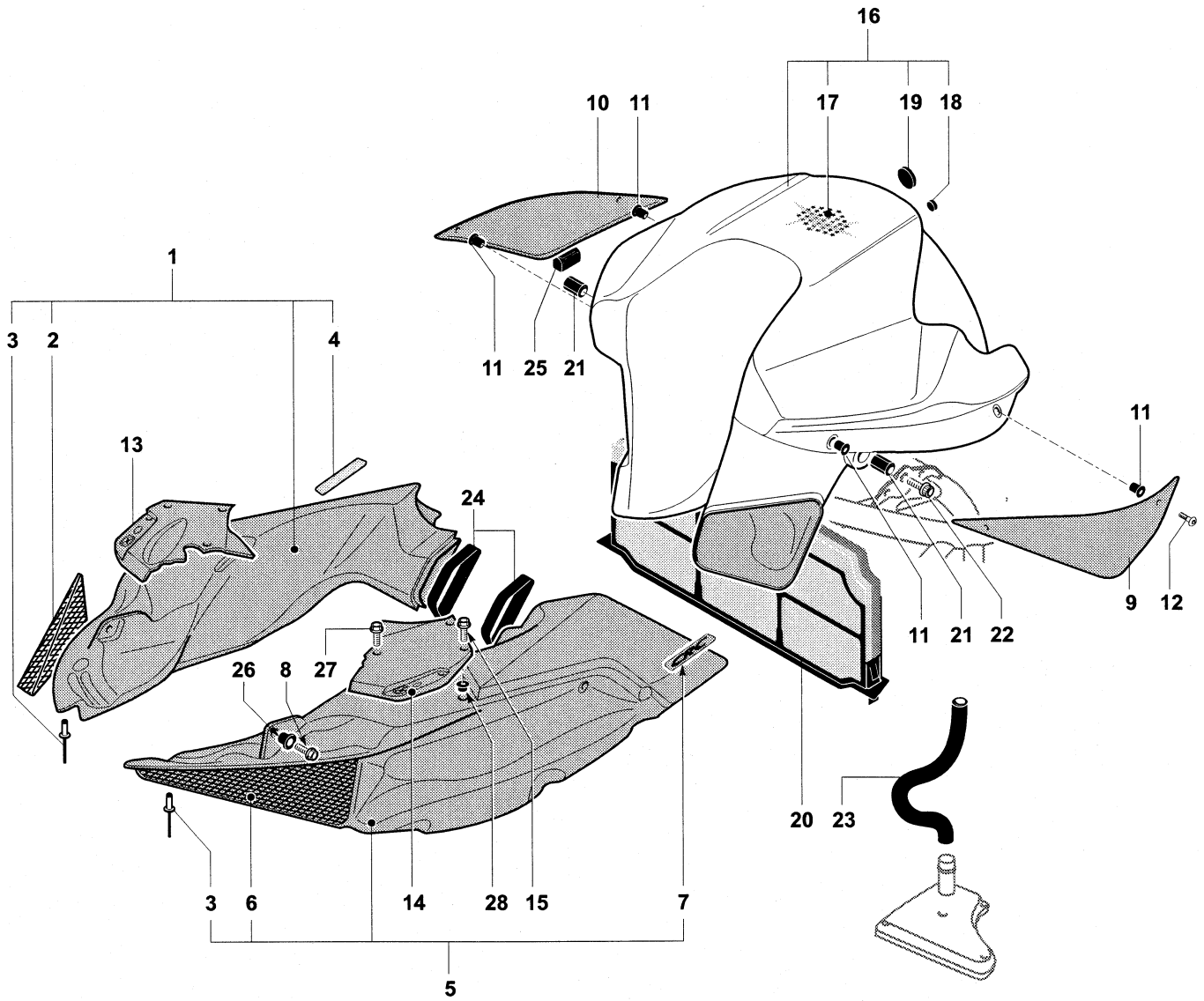

ASSIEME AIRBOX

 AIRBOX ASSEMBLY • ENSEMBLE AIRBOX
 BAUGRUPPE AIRBOX • CONJUNTO AIRBOX

N.	Code	Q.ty	Note	750 S	750 S 1+1	SPR	SR-SR1+1	SENNA	► I FRAME I ►	► I ENGINE I ►
1	800091670	1		•	•		•	•		
1	800098936	1				•				
2	800091630	1		•	•	•	•	•		
3	800093355	4		•	•	•	•	•		
4	800090986	1		•	•	•	•	•		
5	800091671	1		•	•		•	•		
5	800098935	1				•				
6	800091631	1		•	•	•	•	•		
7	800090985	1		•	•	•	•	•		
8	800062726	2		•	•	•	•	•		
9	800090965	1		•	•		•			
9	80A090257	1				•		•		
10	800090964	1		•	•		•			
10	80A090258	1				•		•		
11	800094651	4		•	•	•	•	•		
12	8A0090901	4		•	•	•	•	•		
13	80A090412	1		•	•	•	•	•		
14	80A090413	1		•	•	•	•	•		
15	8B0089786	4		•	•	•	•	•		
16	800091674	1	A	•	•					
16	80A091674	1	B	•	•					
16	80B091674	1	C	•	•					
16	80B091674	1				•				
16	800091674	1					•			
16	80C091674	1						•		
17	800090321	1	A	•	•					
17	80A090321	1	B	•	•					
17	80B090321	1	C	•	•					
17	80B090321	1				•		•		
17	800090321	1					•			
18	800092663	4		•	•	•	•	•		
19	8A0092663	5		•	•	•	•	•		
20	800090348	1		•	•	•	•	•		
21	800091008	2		•	•	•	•	•		
22	8G0090425	2		•	•	•	•	•		
23	800092251	1		•	•	•	•	•		
24	800095816	2		•	•	•	•	•		
25	800094898	2		•	•		•			
26	800090392	2		•	•	•	•	•		
27	800089786	2		•	•	•	•	•		
28	800048245	4		•	•	•	•	•		

A Versione Rosso/Argento - Red/Silver version - Version Rouge/Argent - Rot/Silber Version - Versión Rojo/Plata.

B Versione Argento - Silver version - Version Argent - Silber Version - Versión Plata.

C Versione Nera - Black version - Version Noire - Schwarze Version - Versión Negra.



ASSIEME SERBATOIO BENZINA
FUEL TANK ASSEMBLY • ENSEMBLE RÉSERVOIR DE CARBURANT
BAUGRUPPE TANK • CONJUNTO DEPÓSITO GASOLINA

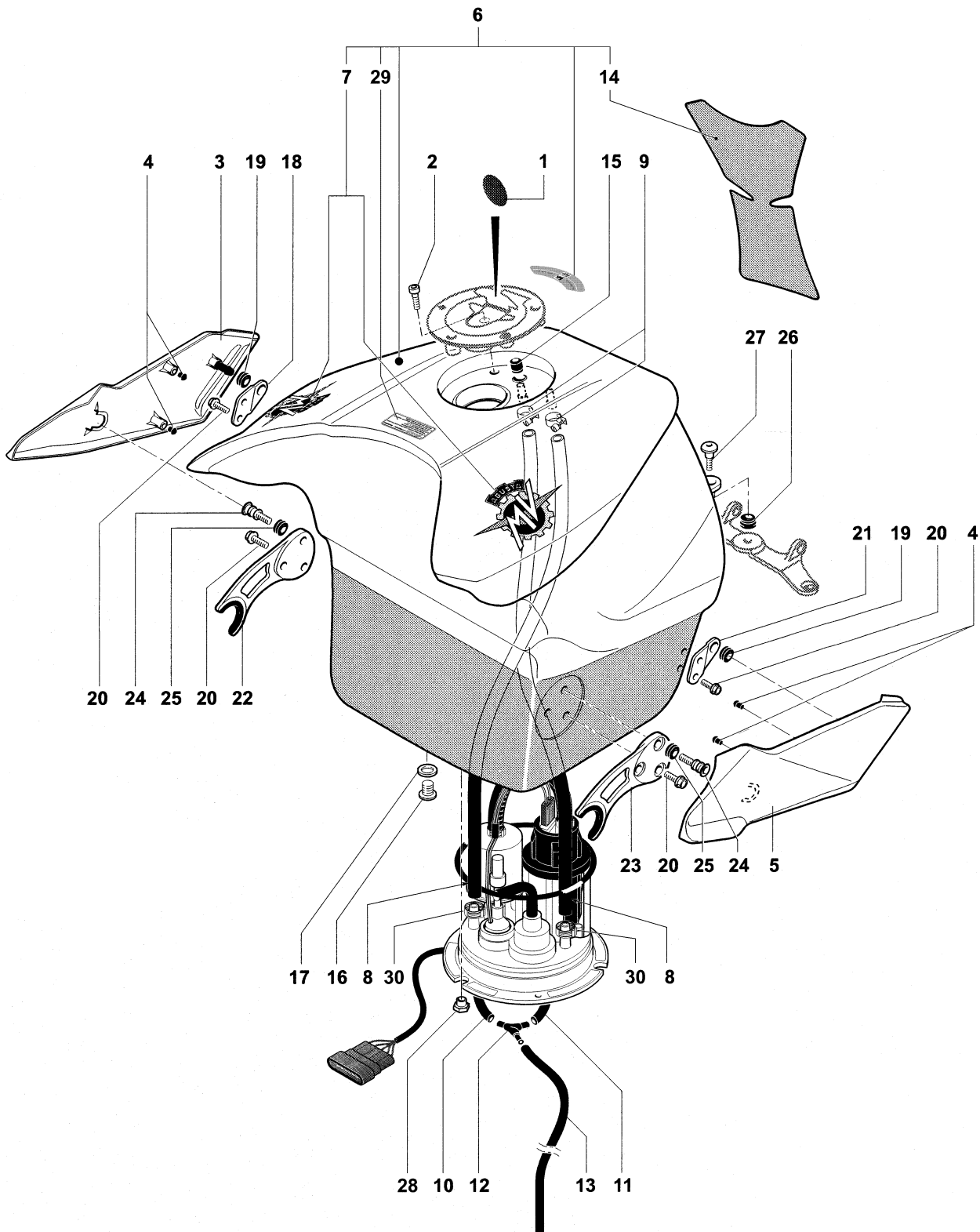

ASSIEME SERBATOIO BENZINA

 FUEL TANK ASSEMBLY • ENSEMBLE RÉSERVOIR DE CARBURANT
 BAUGRUPPE TANK • CONJUNTO DEPÓSITO GASOLINA

N.	Code	Q.ty	Note	750 S	750 S 1+1	SPR	SR-SR1+1	SENNÀ	► I FRAME I ◄	► I ENGINE I ◄
1	800092664	1		•	•	•	•	•		
2	8D0066531	1		•	•	•	•	•		
3	80A090298	1	A	•	•					
3	80B090298	1	B	•	•					
3	80C090298	1	C	•	•					
3	80C090298	1				•				
3	80A090298	1					•			
3	80D090298	1						•		
4	800090978	4		•	•	•	•	•		
5	80A090297	1	A	•	•					
5	80B090297	1	B	•	•					
5	80C090297	1	C	•	•					
5	80C090297	1				•				
5	80A090297	1					•			
5	80D090297	1						•		
6	800091673	1	A	•	•					
6	80A091673	1	B	•	•					
6	80B091673	1	C	•	•					
6	80B091673	1				•				
6	800091673	1					•			
6	80C091673	1						•		
7	800090322	2		•	•	•	•	•		
8	800090940	2	1	•	•	•	•	•		
9	8B0091687	2		•	•	•	•	•		
10	800091695	1	1	•	•	•	•	•		
11	800091690	1	1	•	•	•	•	•		
12	800091689	1	1	•	•	•	•	•		
13	800091688	1		•	•	•	•	•		
14	800095803	1		•	•	•	•	•		
15	800090923	1		•	•	•	•	•		
16	800077921	1		•	•	•	•	•		
17	800021480	1		•	•	•	•	•		
18	800090307	1		•	•	•	•	•		
19	800089293	2		•	•	•	•	•		
20	800062727	8		•	•	•	•	•		
21	800090981	1		•	•	•	•	•		
22	800089784	1		•	•	•	•	•		
23	800089785	1		•	•	•	•	•		
24	800090977	2		•	•	•	•	•		
25	800089293	2		•	•	•	•	•		
26	800091633	1		•	•	•	•	•		
27	800089758	1		•	•	•	•	•		
28	800092270	3		•	•	•	•	•		
29	800095840	1		•	•	•	•	•		
30	8C0092256	2		•	•	•	•	•		

A Versione Rosso/Argento - Red/Silver version - Version Rouge/Argent - Rot/Silber Version - Versión Rojo/Plata.

B Versione Argento - Silver version - Version Argent - Silber Version - Versión Plata.

C Versione Nera - Black version - Version Noire - Schwarze Version - Versión Negra.

1 Esclusi gli USA (vedi tavola K02) - USA excluded (see table K02) - Sauf les USA (voir planche K02) - Ausschließlich USA (siehe Tafel K02)
 - Excluidos los USA (ver tabla K02).



ASSIEME CODONE (MONOPOSTO)

REAR FAIRING ASSEMBLY (SINGLE-SEATER) • ENSEMBLE CARÉNAGE DE SELLE (MONOPLACE)
BAUGRUPPE HECK (EINSITZER) • CONJUNTO COLÍN (MONOPLAZA)

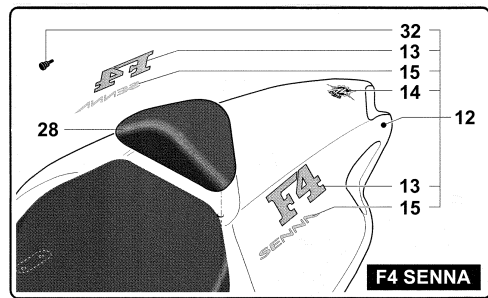
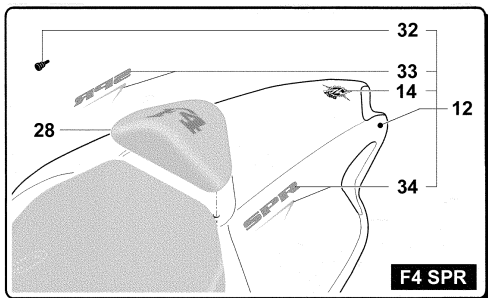
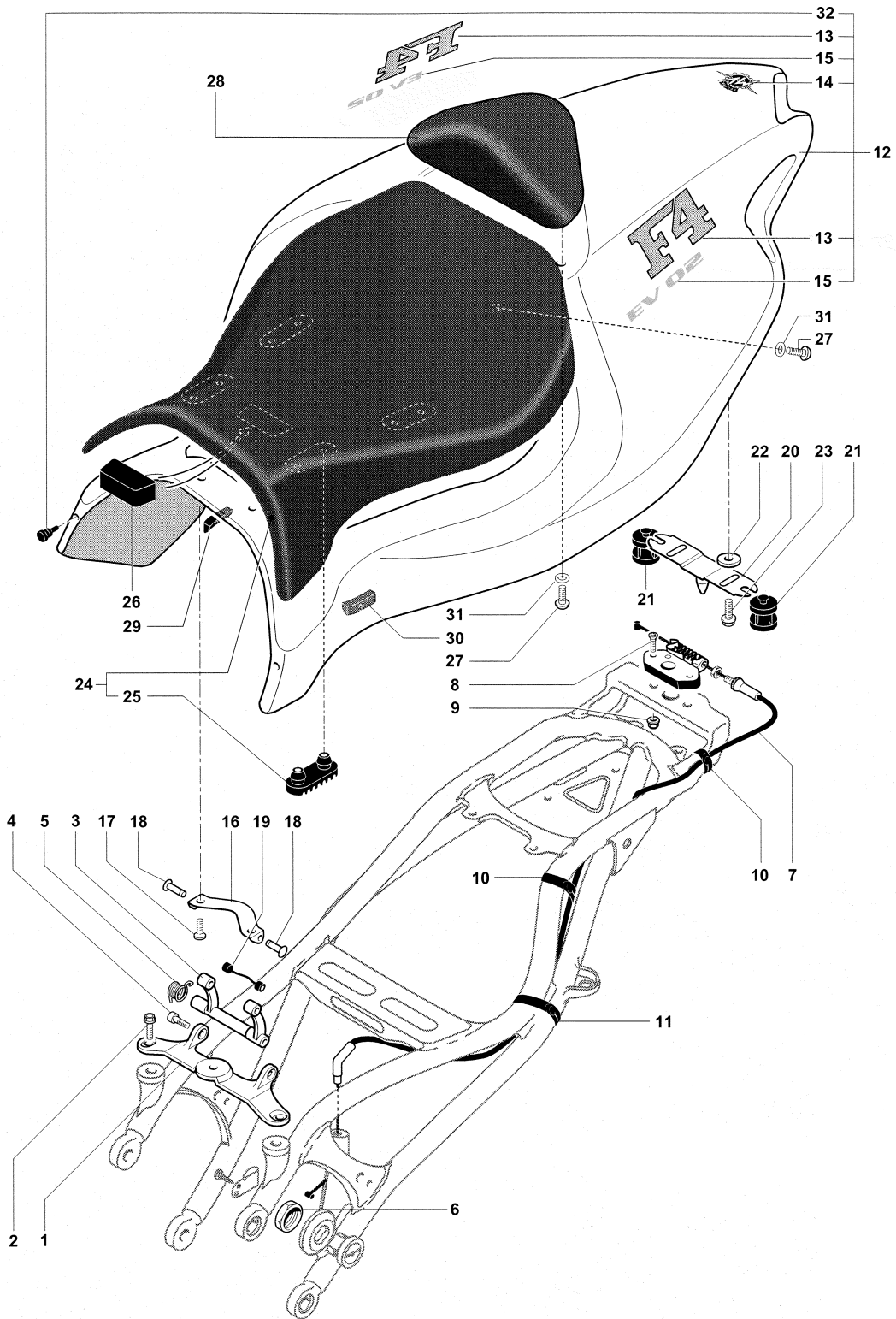

ASSIEME CODONE (MONOPOSTO)

 REAR FAIRING ASSEMBLY (SINGLE-SEATER) • ENSEMBLE CARÉNAGE DE SELLE (MONOPLACE)
 BAUGRUPPE HECK (EINSITZER) • CONJUNTO COLÍN (MONOPLAZA)

N.	Code	Q.ty	Note	750 S	750 S 1+1	SPR	SR	SENNÀ	► I FRAME I ►	► I ENGINE I ►
1	800089802	1		•		•	•	•		
2	800062728	2		•		•	•	•		
3	800089787	1		•		•	•	•		
4	60N102482	2		•		•	•	•		
5	800090243	1		•		•	•	•		
6	800090250	1		•		•	•	•		
7	800090251	1		•		•	•	•		
8	80A026970	2		•		•	•	•		
9	800056443	2		•		•	•	•		
10	800053724	2		•		•	•	•		
11	800092248	1		•		•	•	•		
12	8000A1494	1	A EV 02	•						
12	8AA0A1494	1	B EV 02	•						
12	80B0A1494	1	C EV 02	•						
12	8000A2365	1	A EV 03	•						
12	8AA0A2365	1	B EV 03	•						
12	80B0A2365	1	C EV 03	•						
12	800091672	1	A Euro 2	•						
12	8AA091672	1	B Euro 2	•						
12	80B091672	1	C Euro 2	•						
12	80A098944	1				•				
12	800091672	1					•			
12	800099112	1						•		
13	800090320	2	A C	•						
13	8A0090320	2	B	•						
13	800090320	2					•	•		
14	800090316	1		•		•	•	•		
15	8000A1438	2	1 EV 02	•						
15	8000A1520	1	2 EV 02	•						
15	8000A2366	2	EV 03	•						
15	800099113	2						•		
16	800090344	1		•		•	•	•		
17	8A0090904	2		•		•	•	•		
18	800090905	2		•		•	•	•		
19	800090906	1		•		•	•	•		
20	800090345	1		•		•	•	•		
21	800090893	2		•		•	•	•		
22	800056359	2		•		•	•	•		
23	800062725	2		•		•	•	•		
24	800090379	1		•			•	•		
24	80A090379	1				•				
25	800090380	4		•		•	•	•		
26	800094505	1		•		•	•	•		
27	8AA059572	5		•		•	•	•		
28	800090381	1		•			•	•		
28	8AA090381	1				•				
29	800094899	1		•		•	•	•		
30	800095499	1		•		•	•	•		
31	62N115548	5		•		•	•	•		
32	800095828	2		•		•	•	•		
33	8000A2396	1				•				
34	8000A2395	1				•				

A Versione Rosso/Argento - Red/Silver version - Version Rouge/Argent - Rot/Silber Version - Versión Rojo/Plata.

B Versione Argento - Silver version - Version Argent - Silber Version - Versión Plata.

C Versione Nera - Black version - Version Noire - Schwarze Version - Versión Negra.

1 Da applicare sotto vernice trasparente - To be applied under transparent painting - Appliquer sous vernis transparent - Unter die transparent Firnis kleben - Aplicar debajo de la pintura transparente.

2 Da applicare sopra vernice trasparente - To be applied over transparent painting - Appliquer sur vernis transparent - Auf die transparent Firnis kleben - Aplicar sobre la pintura transparente.



ASSIEME CODONE (BIPOSTO)

REAR FAIRING ASSEMBLY (TWO-SEATER) • ENSEMBLE CARÉNAGE DE SELLE (BIPLACE)
BAUGRUPPE HECK (ZWEISITZER) • CONJUNTO COLÍN (BIPLAZA)

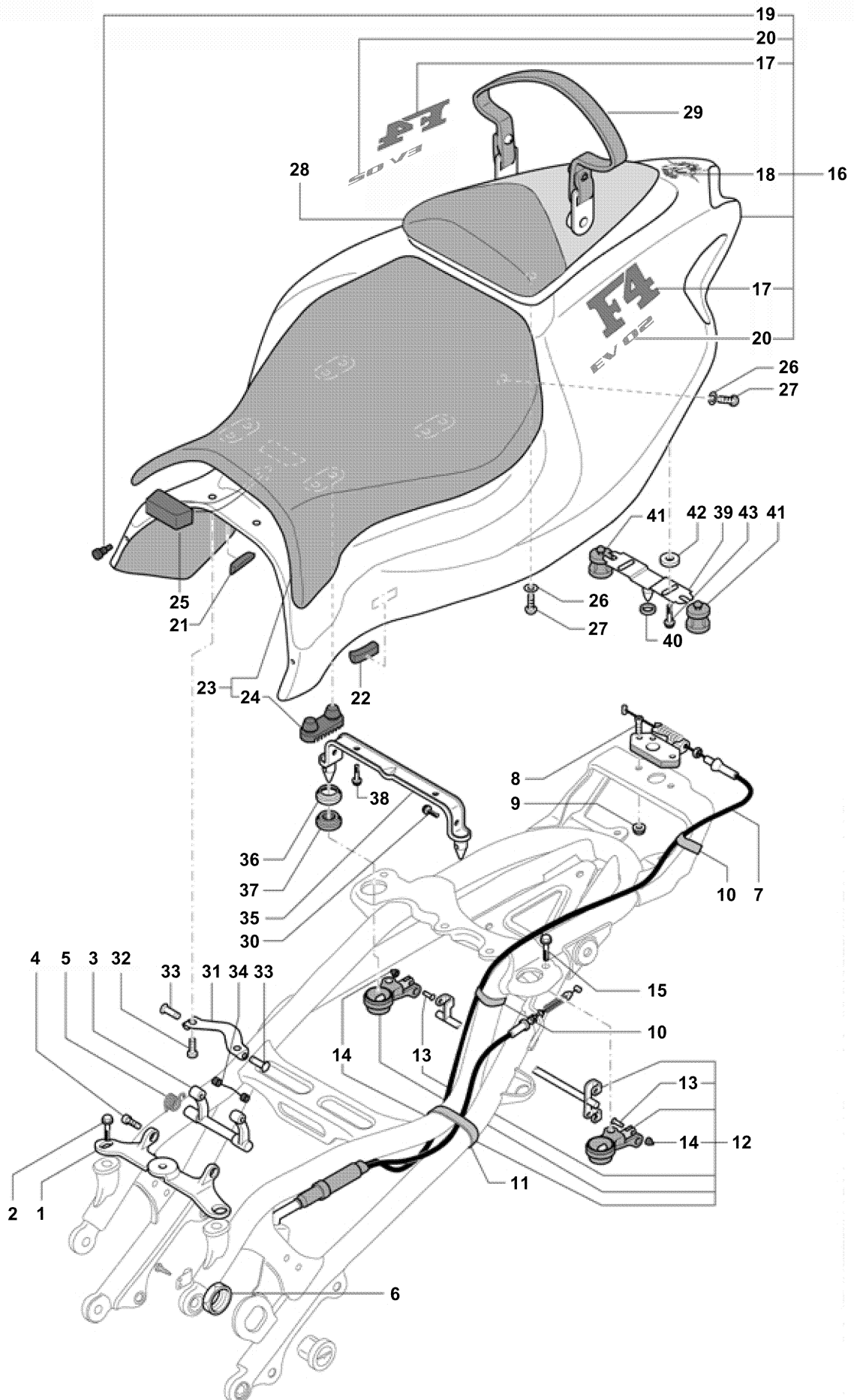

ASSIEME CODONE (BIPOSTO)

 REAR FAIRING ASSEMBLY (TWO-SEATER) • ENSEMBLE CARÉNAGE DE SELLE (BIPLACE)
 BAUGRUPPE HECK (ZWEISITZER) • CONJUNTO COLÍN (BIPLAZA)

N.	Code	Q.ty	Note	750 S	750 S 1+1	SPR	SR 1+1	SENNÀ	► I FRAME I ◄	► I ENGINE I ◄
1	800089802	1			•		•			
2	800062728	2			•		•			
3	800089787	1			•		•			
4	60N102482	2			•		•			
5	800090243	1			•		•			
6	800090250	1			•		•			
7	800094172	1			•		•			
8	80A026970	2			•		•			
9	800056443	2			•		•			
10	800053724	2			•		•			
11	800092248	1			•		•			
12	800094194	1			•		•			
13	800094512	2			•		•			
14	800097077	2			•		•			
15	800095508	2			•		•			
16	8000A1495	1	A EV 02		•					
16	8AA0A1495	1	B EV 02		•					
16	80B0A1495	1	C EV 02		•					
16	8000A2367	1	A EV 03		•					
16	8AA0A2367	1	B EV 03		•					
16	80B0A2367	1	C EV 03		•					
16	800094173	1	A Euro 2		•					
16	8AA094173	1	B Euro 2		•					
16	800094173	1					•			
17	800090320	2	A C		•					
17	8A0090320	2	B		•					
17	800090320	2					•			
18	800090316	1			•		•			
19	800095828	2			•		•			
20	8000A1438	2	1 EV 02		•					
20	8000A1520	1	2 EV 02		•					
20	8000A2366	2	EV 03		•					
21	800094899	1			•		•			
22	800095499	1			•		•			
23	800090379	1			•		•			
24	800090380	4			•		•			
25	800094505	1			•		•			
26	62N115548	7			•		•			
27	8AA059572	7			•		•			
28	800094176	1	A		•					
28	80A094176	1	B		•					
28	80B094176	1	C		•					
28	800094176	1					•			
29	800094178	1			•		•			
30	8D0061070	2			•		•			
31	800090344	1			•		•			
32	8A0090904	2			•		•			
33	800090905	2			•		•			
34	800090906	1			•		•			
35	800094179	1			•		•			
36	800095488	2			•		•			
37	800094182	2			•		•			
38	8H0067545	2			•		•			
39	800090345	1			•		•			
40	800095382	1			•		•			
41	800090893	2			•		•			
42	800056359	2			•		•			
43	8H0067545	2			•		•			

A Versione Rosso/Argento - Red/Silver version - Version Rouge/Argent - Rot/Silber Version - Versión Rojo/Plata.

B Versione Argento - Silver version - Version Argent - Silber Version - Versión Plata.

C Versione Nera - Black version - Version Noire - Schwarze Version - Versión Negra.

1 Da applicare sotto vernice trasparente - To be applied under transparent painting - Appliquer sous vernis transparent - Unter die transparent Firnis kleben - Aplicar debajo de la pintura transparente.

2 Da applicare sopra vernice trasparente - To be applied over transparent painting - Appliquer sur vernis transparent - Auf die transparent Firnis kleben - Aplicar sobre la pintura transparente.



IMPIANTO ELETTRICO
ELECTRIC SYSTEM • INSTALLATION ÉLECTRIQUE
ELEKTRISCHE ANLAGE • INSTALACIÓN ELÉCTRICA

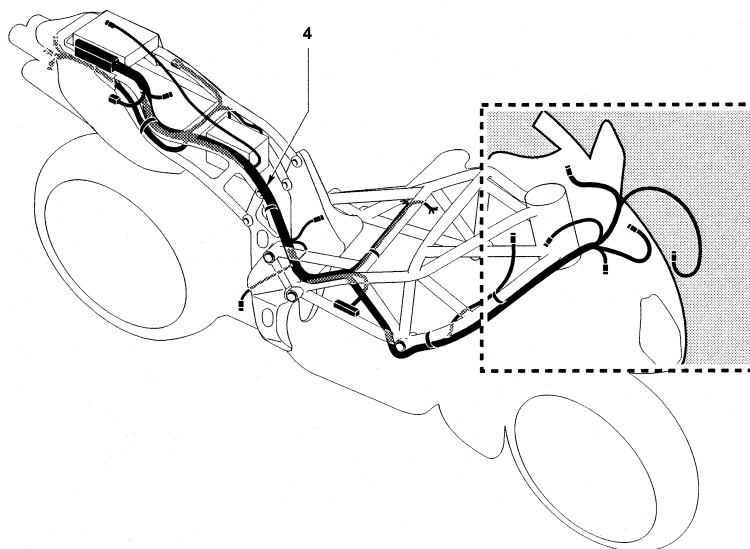
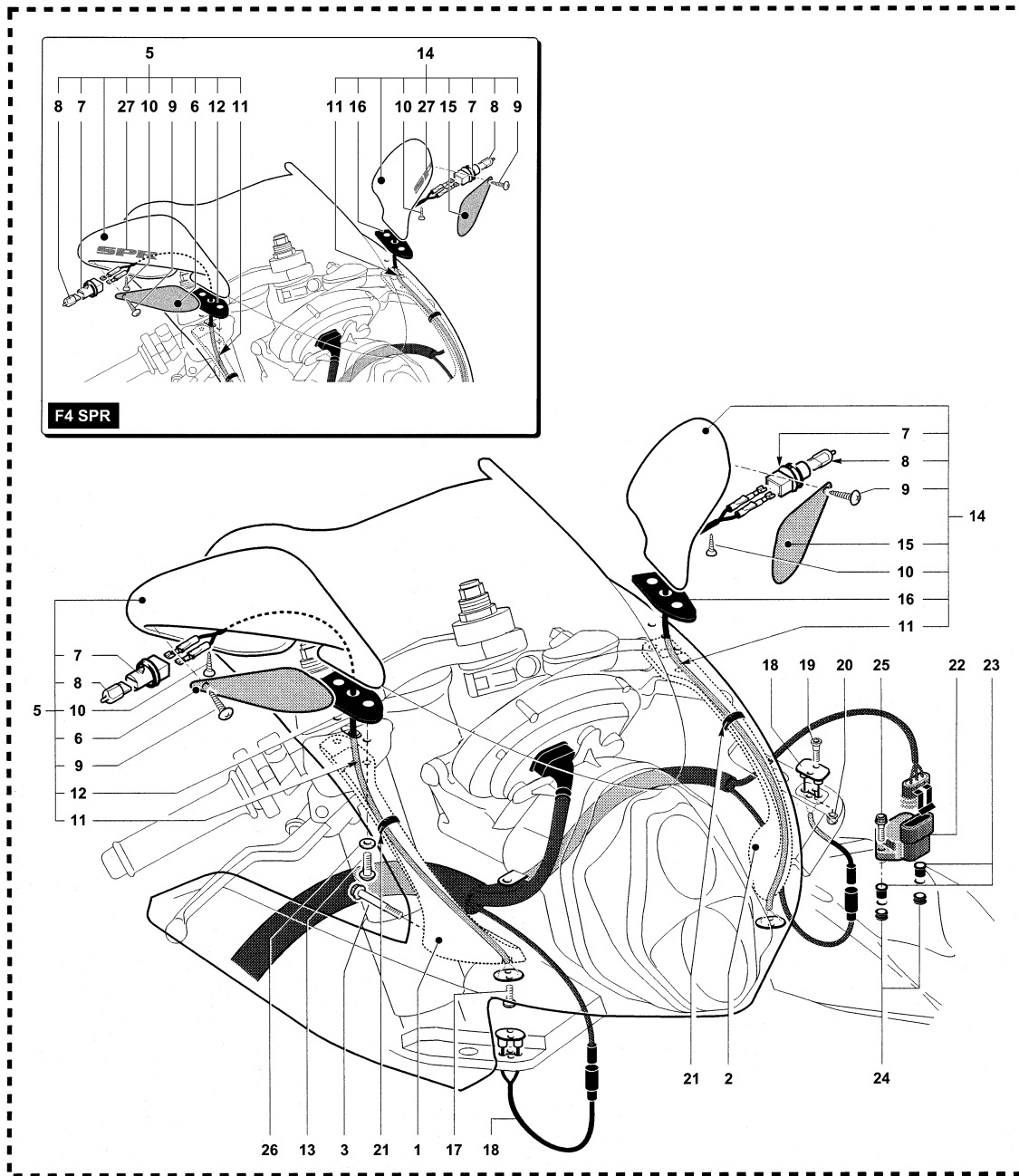



N.	Code	Q.ty	Note	750 S	750 S 1+1	SPR	SR-SR1+1	SENNA	► I FRAME I ►	► I ENGINE I ►
1	80A090246	1	①	•	•					
1	8AA090246	1	②	•	•					
1	8AA090246	1				•	•			
1	80A090246	1						•		
2	80A090247	1	①	•	•					
2	8AA090247	1	②	•	•					
2	8AA090247	1				•	•			
2	80A090247	1						•		
3	8S0090425	2		•	•	•	•	•		
4	800095353	1		•	•	•	•	•		
5	800090370	1	A	•	•					
5	80A090370	1	B	•	•					
5	80B090370	1	C	•	•					
5	8000A2402	1				•				
5	800090370	1					•			
5	80C090370	1						•		
6	800093332	1		•	•	•	•	•		
7	800093417	2		•	•	•	•	•		
8	800093418	2		•	•	•	•	•		
9	800037290	2		•	•	•	•	•		
10	800093851	4		•	•	•	•	•		
11	800090405	2		•	•	•	•	•		
12	800093420	1		•	•	•	•	•		
13	800044014	4		•	•	•	•	•		
14	800090371	1	A	•	•					
14	80A090371	1	B	•	•					
14	80B090371	1	C	•	•					
14	8000A2401	1				•				
14	800090371	1					•			
14	80C090371	1						•		
15	800093333	1		•	•	•	•	•		
16	800093419	1		•	•	•	•	•		
17	800090909	4	①	•	•					
17	8A0093346	4	②	•	•					
17	8A0093346	4				•	•			
17	800090909	4						•		
18	800090406	2		•	•	•	•	•		
19	800093346	4		•	•	•	•	•		
20	800093345	4		•	•	•	•	•		
21	800053724	2		•	•	•	•	•		
22	800089398	1		•	•	•	•	•		
23	800090910	2		•	•	•	•	•		
24	800089293	2		•	•	•	•	•		
25	8D0090424	2		•	•	•	•	•		
26	800095817	4		•	•	•	•	•		
27	8000A2394	2				•				

A Versione Rosso/Argento - Red/Silver version - Version Rouge/Argent - Rot/Silber Version - Versión Rojo/Plata.

B Versione Argento - Silver version - Version Argent - Silber Version - Versión Plata.

C Versione Nera - Black version - Version Noire - Schwarze Version - Versión Negra.

① - Valido per i motocicli con i seguenti numeri di matricola: - Gültig für die Motorräder mit den folgenden Kennnummern:
- Valid for the motorbikes with the following serial numbers: - Válido para las motos con los números de serie
- Valide pour les motocyclettes avec les matricules suivantes: siguientes:
► I 005594 ; 005596 I ► I 005608 ; 005610 I ► I 005623 ; 005625 ; 005627 ; 005629 I ► I 005634 ; 005636 I ► I 005643 ;
005645 I ► I 005648 ; 005650 I ► I 005653 ; 005655 I ► I 005656 ; 005658 ; 005660 I ► I 005663 ; 005667 ; 005670 I ► I 005671 ;
005677 I ► I 005678 ; 005680 ; 005687 I ► I 005689 ; 005691 I ► I 005697 ; 005699 I ► I 005702 ; 005705 I ► I 005707 ;
005709 ; 005711 I ► I 005725 ; 005727 ; 005736.

② - Valido per i motocicli con i seguenti numeri di matricola: - Gültig für die Motorräder mit den folgenden Kennnummern:
- Valid for the motorbikes with the following serial numbers: - Válido para las motos con los números de serie
- Valide pour les motocyclettes avec les matricules suivantes: siguientes:
005595 ; 005609 ; 005624 ; 005626 ; 005628 ; 005635 ; 005644 ; 005649 ; 005654 ; 005657 ; 005659 ; 005664 I ► I 005666 ;
005668 I ► I 005669 ; 005672 I ► I 005676 ; 005679 ; 005681 I ► I 005686 ; 005690 ; 005698 ; 005703 I ► I 005704 ; 005708 ;
005710 ; 005726 ; 005728 I ► I 005735 ; 005737 ► I .



IMPIANTO ELETTRICO
ELECTRIC SYSTEM • INSTALLATION ÉLECTRIQUE
ELEKTRISCHE ANLAGE • INSTALACIÓN ELÉCTRICA

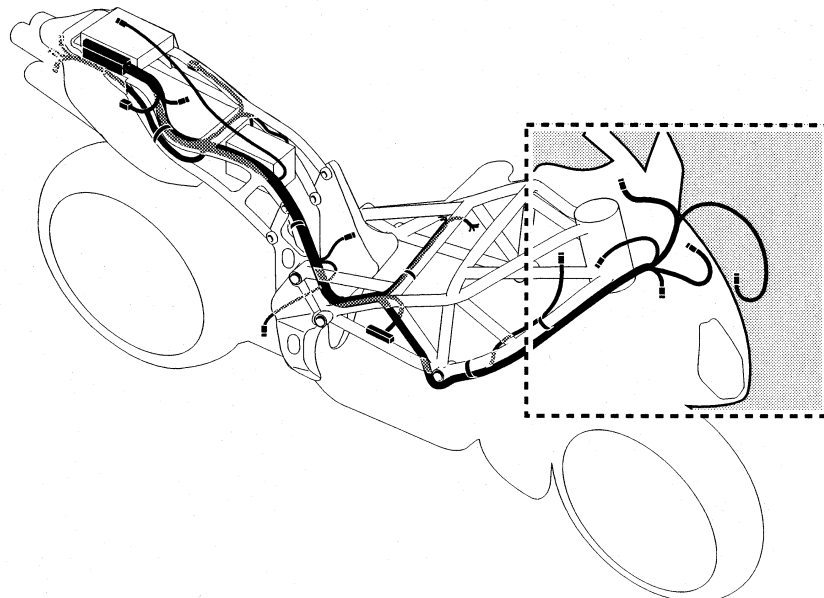
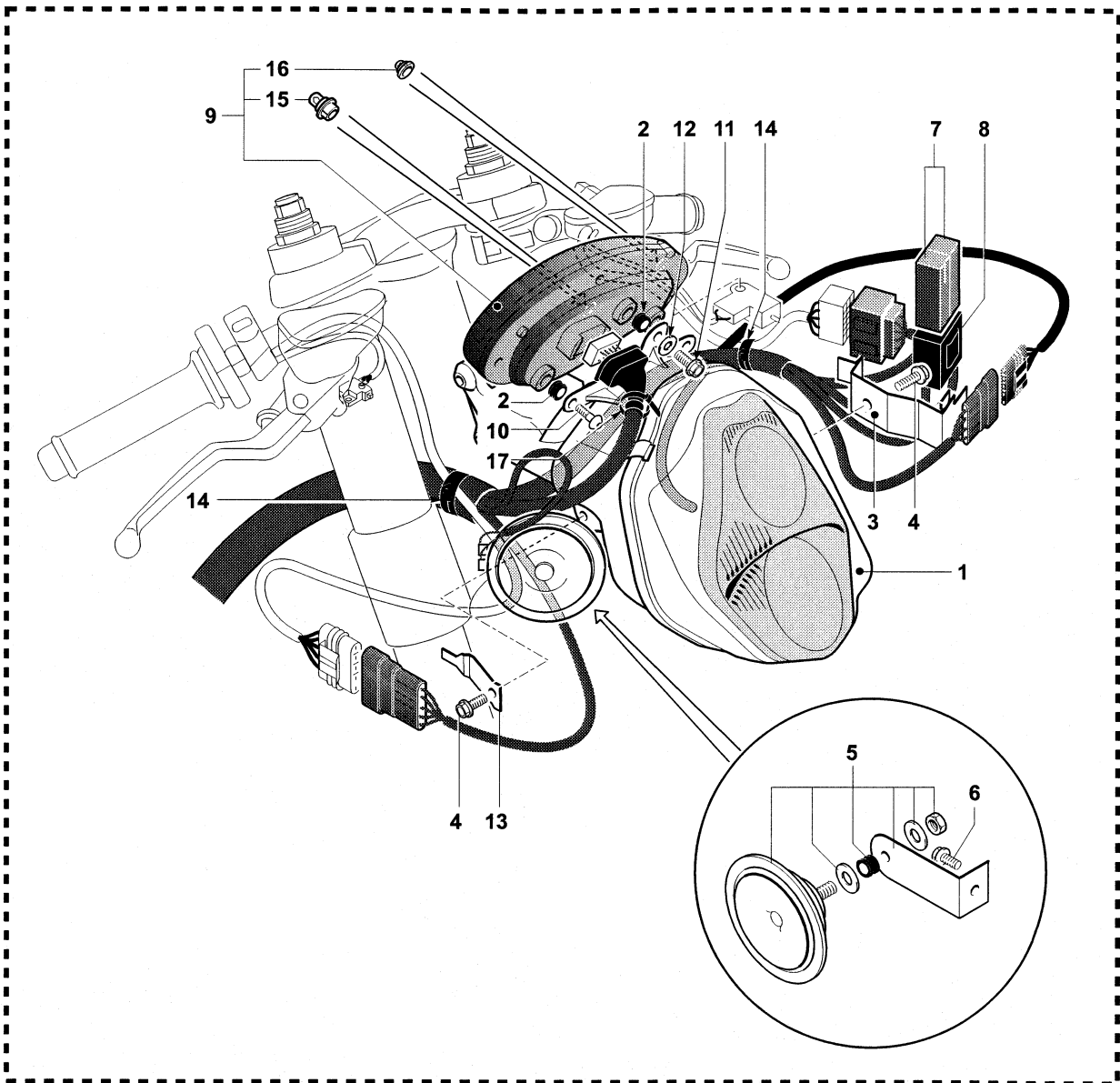



N.	Code	Q.ty	Note	750 S	750 S 1+1	SPR	SR-SR1+1	SENNA	► I FRAME I ►	► I ENGINE I ►
1	800090912	1	①	•	•	•	•	•		
1	800094507	1	②	•	•	•	•	•		
1	800094509	1	USA	•	•	•	•	•		
2	800090239	3		•	•	•	•	•		
3	800090241	1		•	•	•	•	•		
4	800062725	2		•	•	•	•	•		
5	800090946	1		•	•	•	•	•		
6	800062727	1		•	•	•	•	•		
7	800088572	2		•	•	•	•	•		
8	800091001	1		•	•	•	•	•		
9	800090386	1		•	•					
9	800097102	1				•		•		
9	8000A2462	1					•			
10	800092659	2		•	•	•	•	•		
11	8D0067997	1		•	•	•	•	•		
12	62N115548	1		•	•	•	•	•		
13	800090240	1		•	•	•	•	•		
14	800092247	2		•	•	•	•	•		
15	800094860	1		•	•	•	•	•		
16	800094861	1		•	•	•	•	•		
17	800092661	1		•	•	•	•	•		

① Per guida a destra - For right-hand drive - Pour conduite à droite - Für Rechtslenkung - Para conducción a la derecha
② Per guida a sinistra - For left-hand drive - Pour conduite à gauche - Für Linkslenkung - Para conducción a la izquierda



PROIETTORE ANTERIORE
FRONT HEADLIGHT • PROJECTEUR AVANT
SCHEINWERFER • PROYECTOR DELANTERO

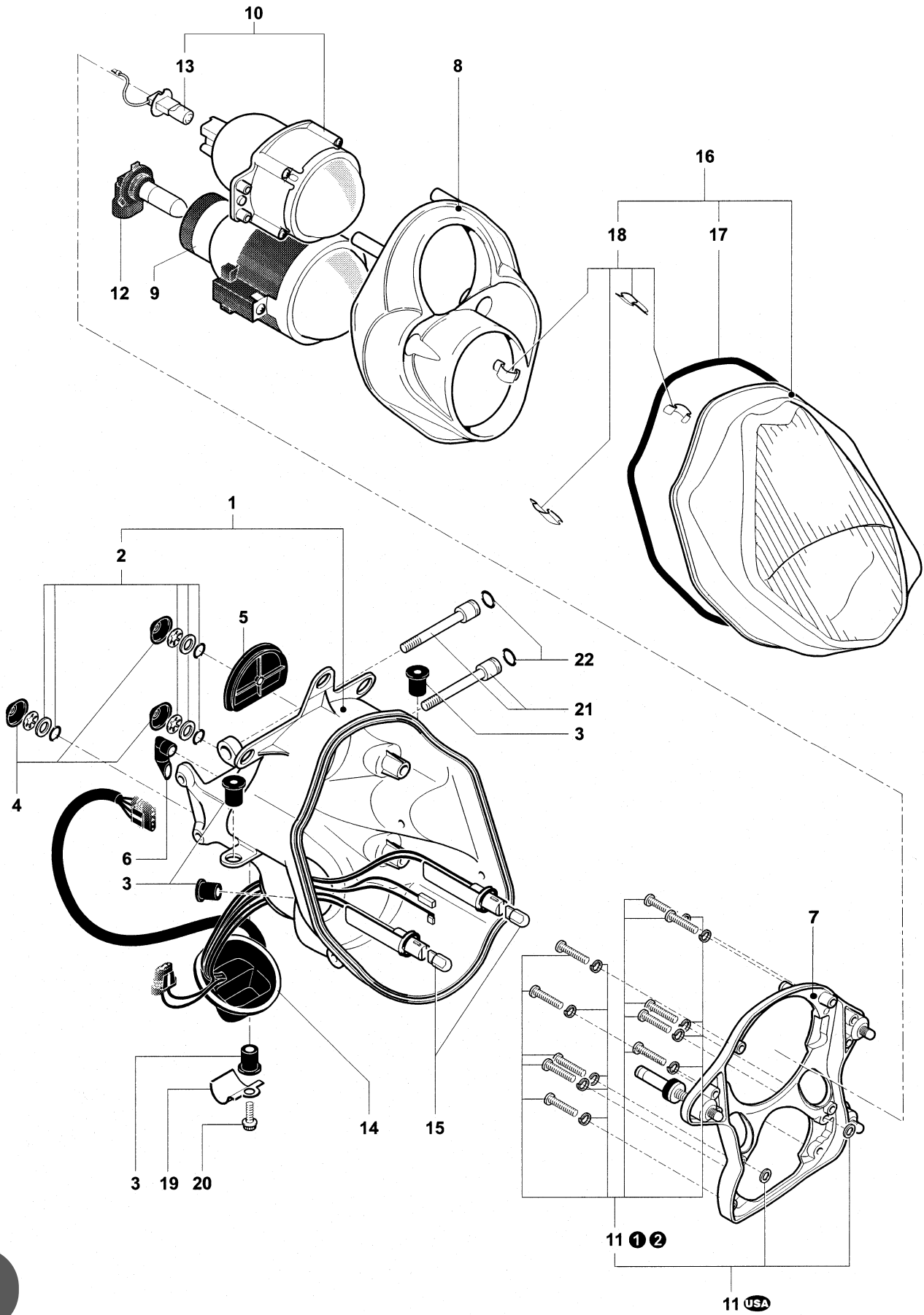

PROIETTORE ANTERIORE
 FRONT HEADLIGHT • PROJECTEUR AVANT
 SCHEINWERFER • PROYECTOR DELANTERO



N.	Code	Q.ty	Note	750 S	750 S 1+1	SPR	SR-SR1+1	SENNA	► I FRAME I ►	► I ENGINE I ►
1	800093328	1		•	•	•	•	•		
2	800094526	1		•	•	•	•	•		
3	800048245	4		•	•	•	•	•		
4	800086459	3		•	•	•	•	•		
5	800090363	1		•	•	•	•	•		
6	800093329	1		•	•	•	•	•		
7	800093330	1		•	•	•	•	•		
8	800090365	1		•	•	•	•	•		
9	800091685	1		•	•	•	•	•		
10	800091684	1	①	•	•	•	•	•		
10	800094522	1	②	•	•	•	•	•		
10	800094523	1	USA	•	•	•	•	•		
11	800094521	1	① ②	•	•	•	•	•		
11	800094637	1	USA	•	•	•	•	•		
12	800093331	1		•	•	•	•	•		
13	800079673	1		•	•	•	•	•		
14	800091217	1		•	•	•	•	•		
15	800036230	2		•	•	•	•	•		
16	800093334	1		•	•	•	•	•		
17	800090367	1		•	•	•	•	•		
18	800090368	4		•	•	•	•	•		
19	800090915	1		•	•	•	•	•		
20	8F0090425	1		•	•	•	•	•		
21	800090242	2		•	•	•	•	•		
22	800023107	2		•	•	•	•	•		

① Per guida a destra - For right-hand drive - Pour conduite à droite - Für Rechtslenkung - Para conducción a la derecha
 ② Per guida a sinistra - For left-hand drive - Pour conduite à gauche - Für Linkslenkung - Para conducción a la izquierda



IMPIANTO ELETTRICO
ELECTRIC SYSTEM • INSTALLATION ÉLECTRIQUE
ELEKTRISCHE ANLAGE • INSTALACIÓN ELÉCTRICA

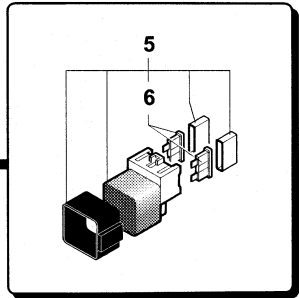
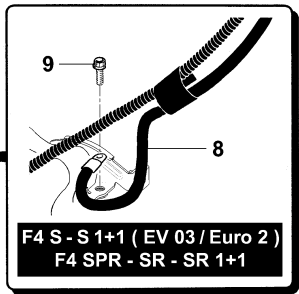
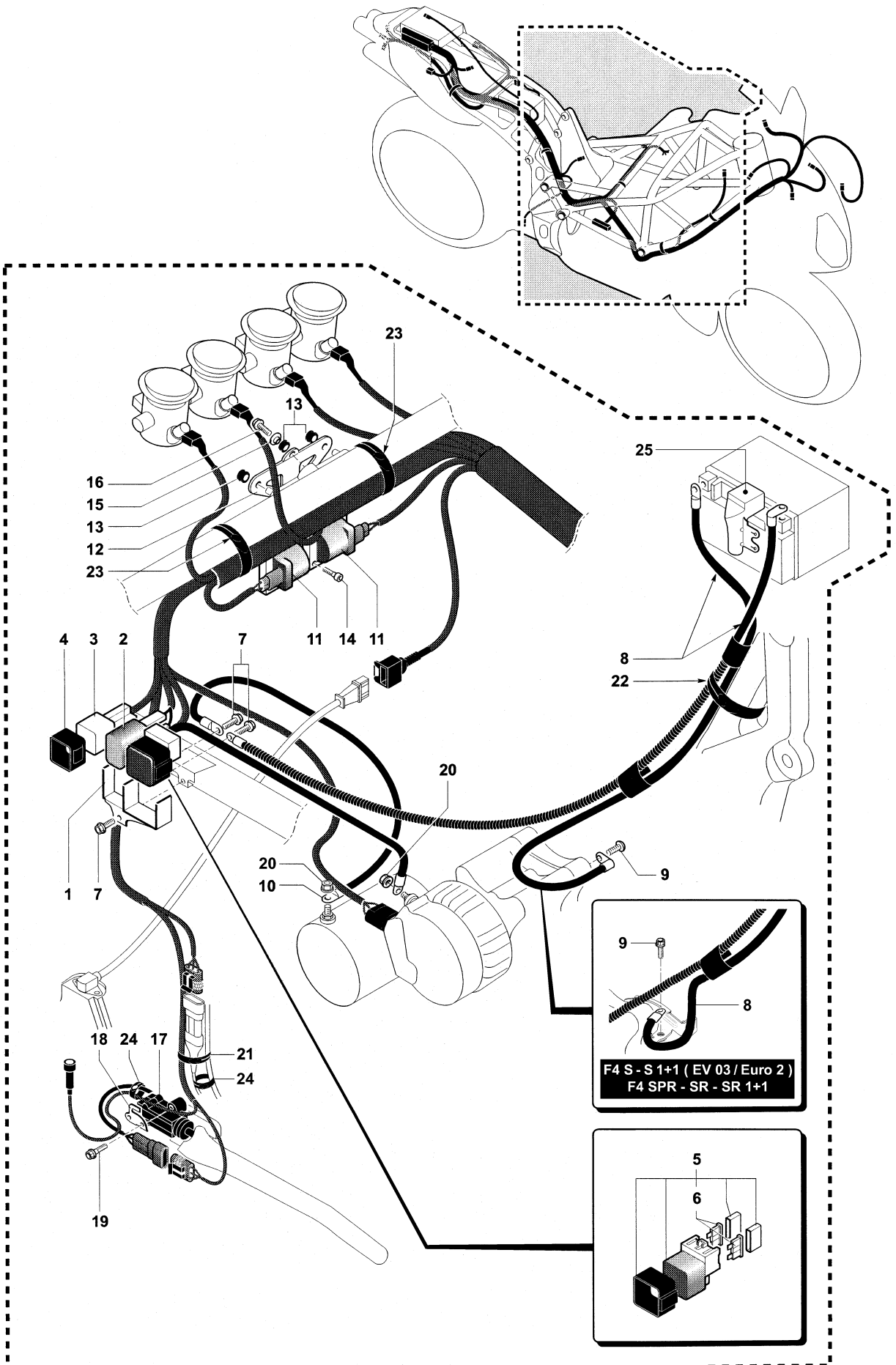



N.	Code	Q.ty	Note	750 S	750 S 1+1	SPR	SR-SR1+1	SENNA	► I FRAME I ►	► I ENGINE I ►
1	800090390	1		•	•	•	•	•		
2	800088173	1		•	•	•	•	•		
3	800094439	1		•	•	•	•	•		
4	800090394	1		•	•	•	•	•		
5	800091115	1		•	•	•	•	•		
6	800093018	2		•	•	•	•	•		
7	8SA067545	3		•	•	•	•	•		
8	800091114	1	EV 02	•	•					
8	8000A2363	1	EV 03 / Euro 2	•	•					
8	8000A2363	1				•	•			
8	800091114	1						•		
9	800092876	1	EV 02	•	•					
9	8SA067545	1	EV 03 / Euro 2	•	•					
9	8SA067545	1				•	•			
9	800092876	1						•		
10	800089965	1		•	•	•	•	•		
11	800091235	2		•	•	•	•	•		
12	800089754	1		•	•	•	•	•		
13	800089293	3		•	•	•	•	•		
14	60N102467	4		•	•	•	•	•		
15	800044099	1		•	•	•	•	•		
16	800062727	1		•	•	•	•	•		
17	800090375	1		•	•	•	•	•		
18	800091653	1		•	•	•	•	•		
19	8H0090424	2		•	•	•	•	•		
20	800037901	2		•	•	•	•	•		
21	800053724	1		•	•	•	•	•		
22	800092247	1		•	•	•	•	•		
23	800092248	2		•	•	•	•	•		
24	800092668	2		•	•	•	•	•		
25	800094890	1		•	•	•	•	•		



IMPIANTO ELETTRICO
ELECTRIC SYSTEM • INSTALLATION ÉLECTRIQUE
ELEKTRISCHE ANLAGE • INSTALACIÓN ELÉCTRICA

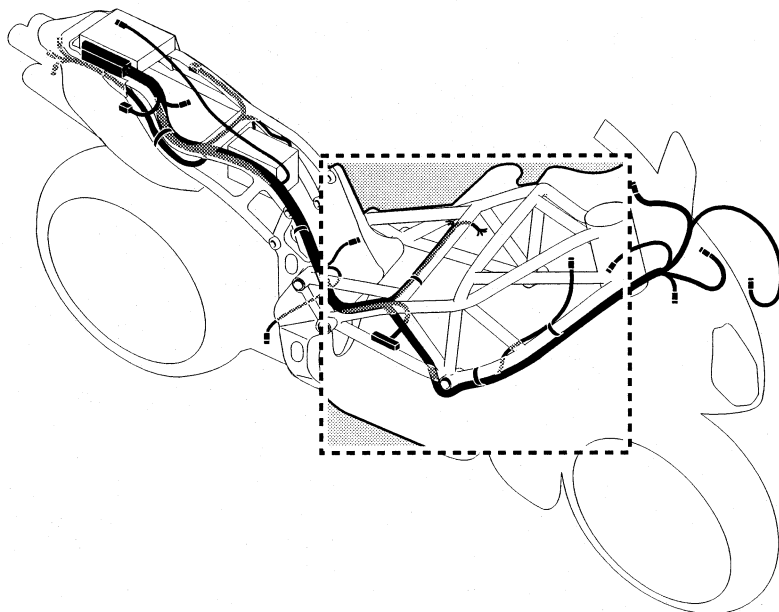
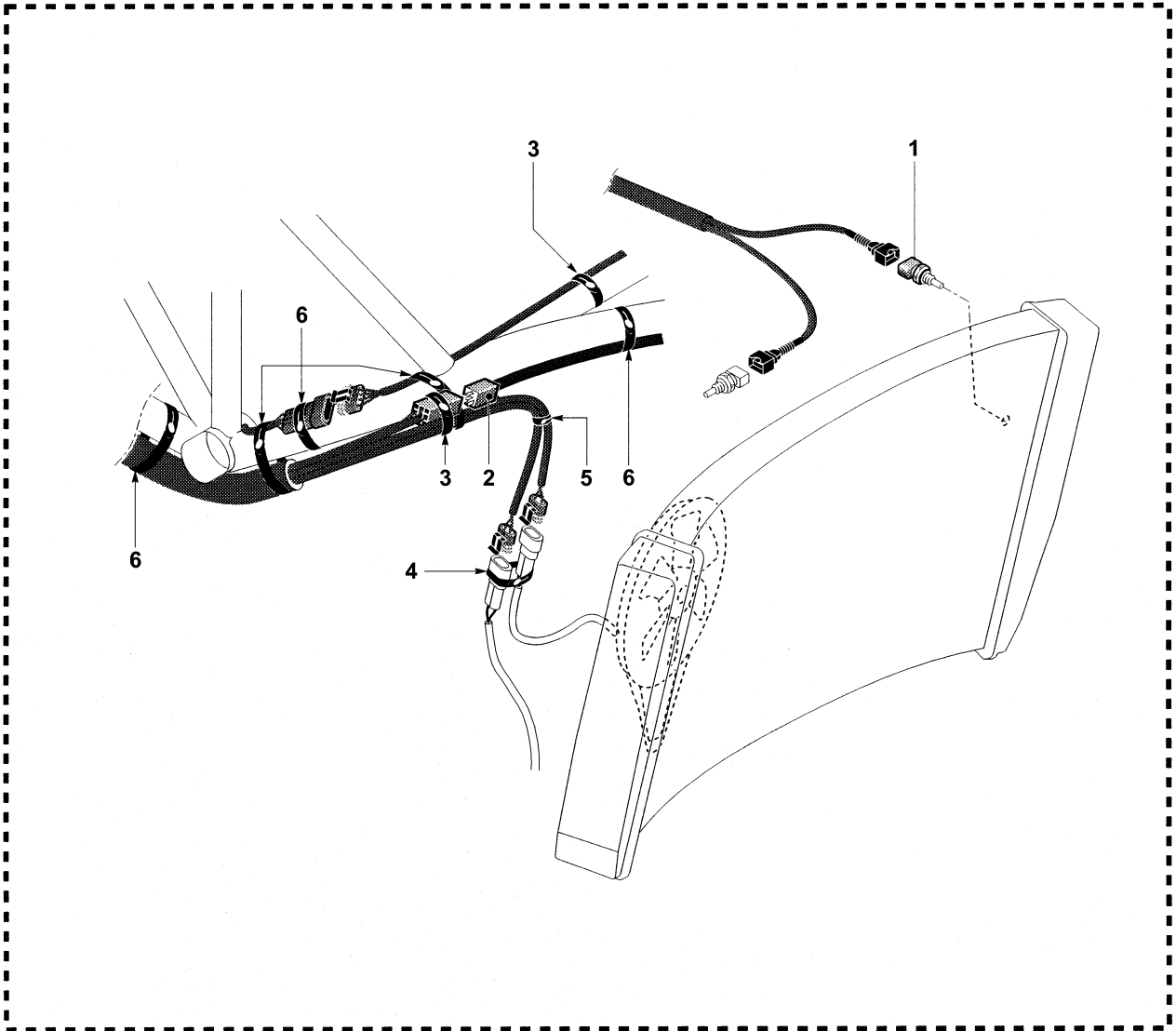

IMPIANTO ELETTRICOELECTRIC SYSTEM • INSTALLATION ÉLECTRIQUE
ELEKTRISCHE ANLAGE • INSTALACIÓN ELÉCTRICA

N.	Code	Q.ty	Note	750 S	750 S 1+1	SPR	SR-SR1+1	SENNA	► I FRAME I ►	► I ENGINE I ►
1	800088575	1		•	•	•	•	•		
2	800088572	1		•	•	•	•	•		
3	800092247	2		•	•	•	•	•		
4	800053724	1		•	•	•	•	•		
5	800092668	1		•	•	•	•	•		
6	800092248	5		•	•	•	•	•		



IMPIANTO ELETTRICO
ELECTRIC SYSTEM • INSTALLATION ÉLECTRIQUE
ELEKTRISCHE ANLAGE • INSTALACIÓN ELÉCTRICA

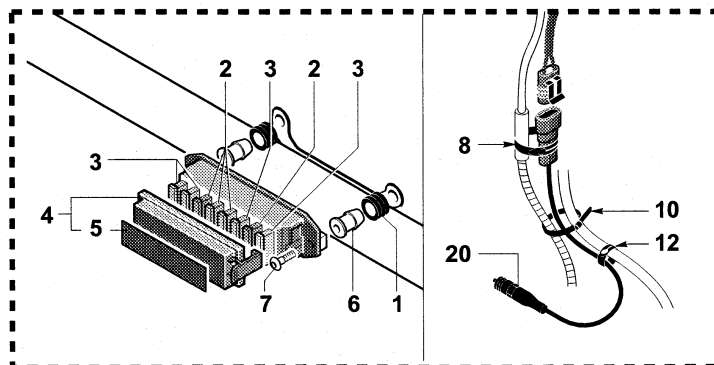
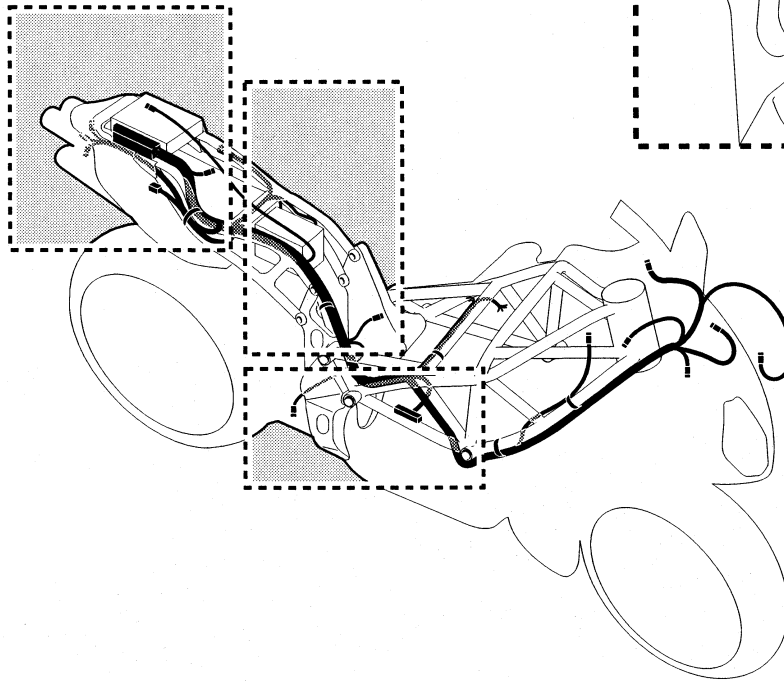
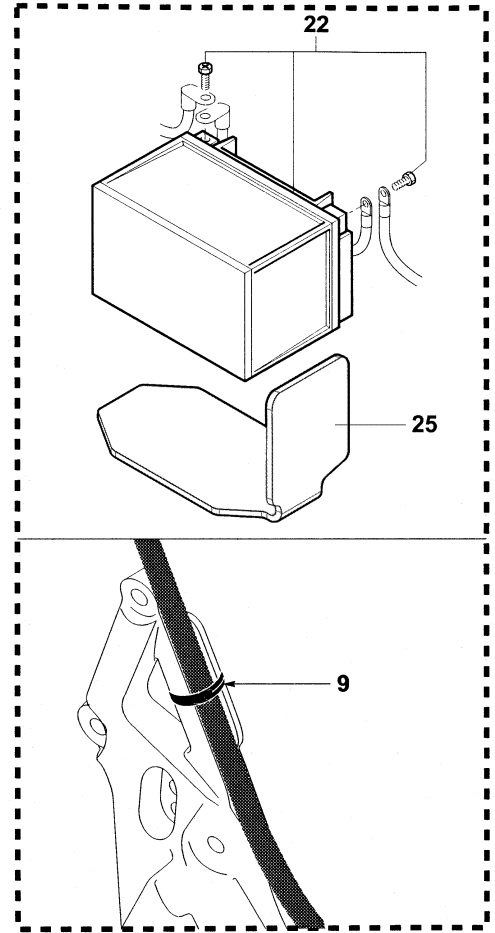
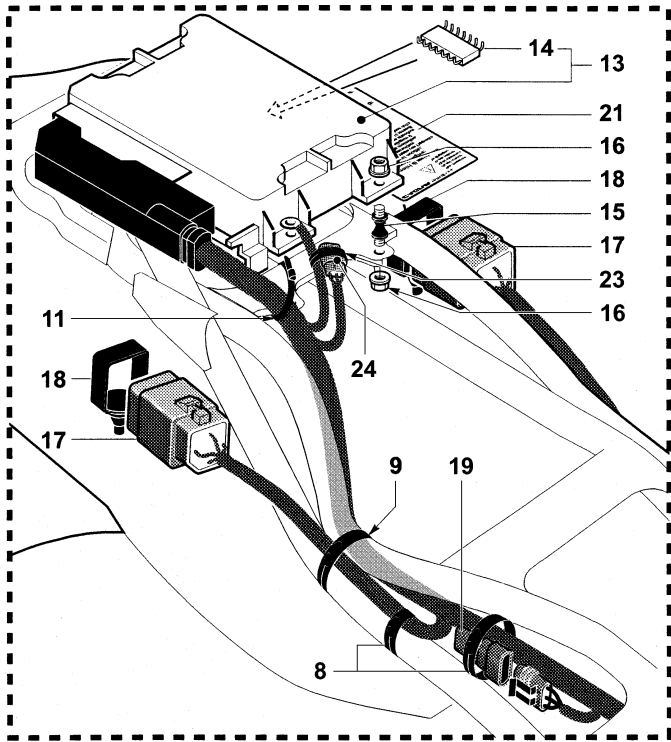



N.	Code	Q.ty	Note	750 S	750 S 1+1	SPR	SR-SR1+1	SENNA	► I FRAME I ►	► I ENGINE I ►
1	800089293	2		•	•	•	•	•		
2	800047470	4		•	•	•	•	•		
3	800047472	4		•	•	•	•	•		
4	800091216	1		•	•	•	•	•		
5	800090214	1		•	•	•	•	•		
6	800090910	2		•	•	•	•	•		
7	80A065535	2		•	•	•	•	•		
8	800092247	3		•	•	•	•	•		
9	800092248	2		•	•	•	•	•		
10	800092661	1		•	•	•	•	•		
11	800056444	1		•	•	•	•	•		
12	800053724	1		•	•	•	•	•		
13	8P0088581	1		•	•				► I 004611	
13	8P0088581	1	USA	•					► I 100436	
13	8P0088581	1	USA		•				► I 200149	
13	8L0088581	1		•	•				004718 I ►	
13	8000A3749	1	1 Euro 2	•	•					
13	8L0088581	1	USA	•					100437 I ►	
13	8L0088581	1	USA		•				200150 I ►	
13	8M0088581	1	F	•	•					
EV 02 / EV 03										
13	8A00A3749	1	F Euro 2	•	•					
13	8U0088581	1	JPN	•	•				► I 004611	
13	8W0088581	1	JPN	•	•				004718 I ►	
13	8000A3749	1	JPN Euro 2	•	•					
13	8R0088581	1				•	•			
13	8T0088581	1	F			•	•			
13	8Y0088581	1	JPN			•	•			
13	8G0088581	1						•		
13	8K0088581	1	F					•		
13	8V0088581	1	JPN					•		
14	8H0095427	1		•	•				► I 004611	
14	8H0095427	1	USA	•					► I 100436	
14	8H0095427	1	USA		•				► I 200149	
14	8E0095427	1		•	•				004718 I ►	
14	8000A3751	1	1 Euro 2	•	•					
14	8E0095427	1	USA	•					100437 I ►	
14	8E0095427	1	USA		•				200150 I ►	
14	8F0095427	1	F	•	•					
EV 02 / EV 03										
14	8A00A3751	1	F Euro 2	•	•					
14	8N0095427	1	JPN	•	•				► I 004611	
14	8R0095427	1	JPN	•	•				004718 I ►	
14	8000A3751	1	JPN Euro 2	•	•					
14	8J0095427	1				•	•			
14	8M0095427	1	F			•	•			
14	8S0095427	1	JPN			•	•			
14	8A0095427	1						•		
14	8D0095427	1	F					•		
14	8P0095427	1	JPN					•		
15	800090913	4		•	•	•	•	•		





IMPIANTO ELETTRICO
ELECTRIC SYSTEM • INSTALLATION ÉLECTRIQUE
ELEKTRISCHE ANLAGE • INSTALACIÓN ELÉCTRICA

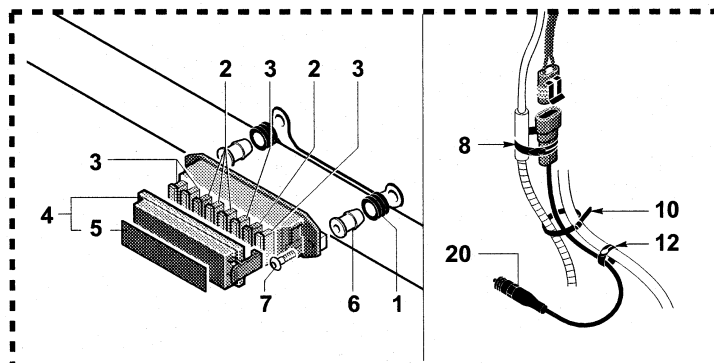
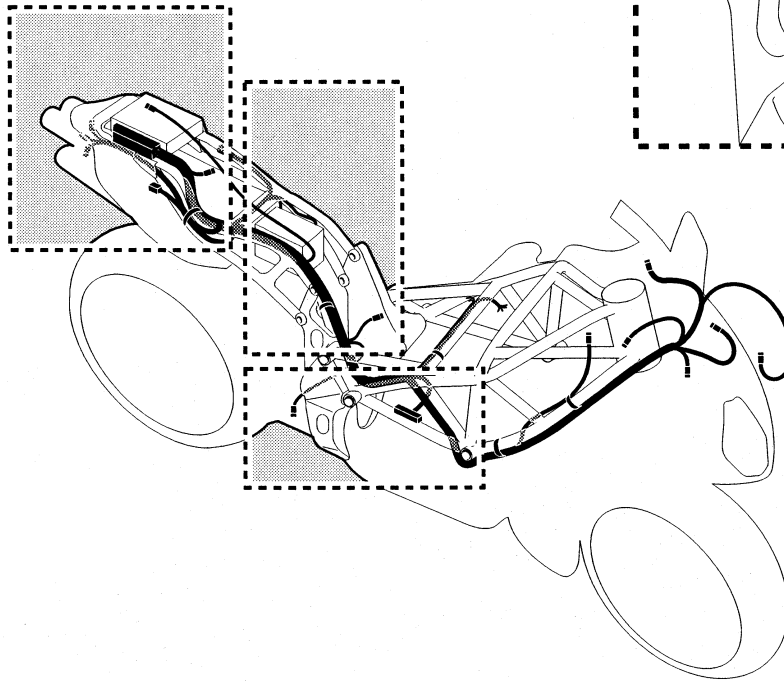
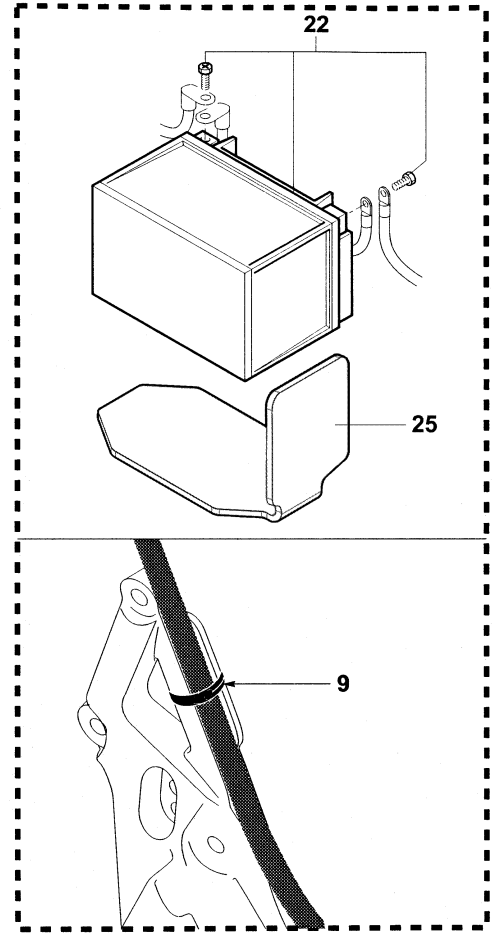
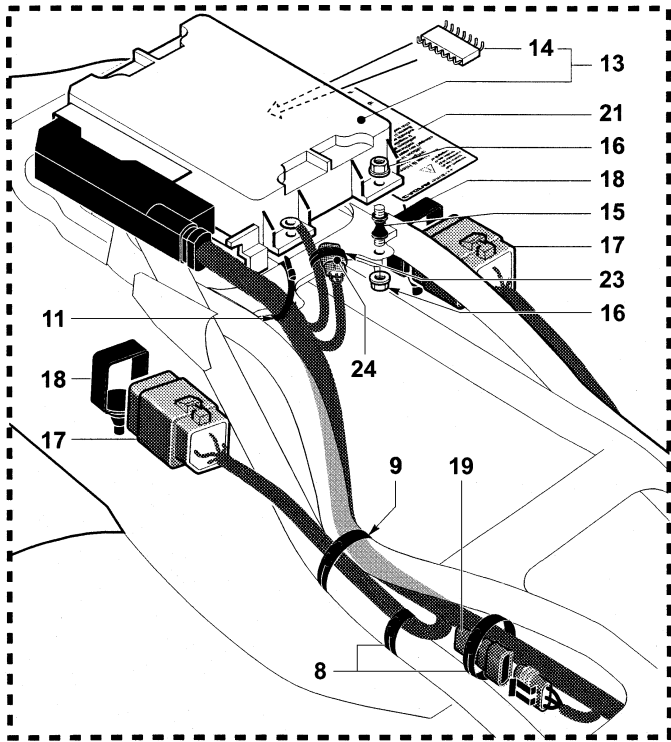



N.	Code	Q.ty	Note	750 S	750 S 1+1	SPR	SR-SR1+1	SENNA	► I FRAME I ►	► I ENGINE I ►
16	800037901	8		•	•	•	•	•		
17	800094116	2		•	•	•	•	•		
18	800067548	2		•	•	•	•	•		
19	800088515	1		•	•	•	•	•		
20	800090213	1		•	•	•	•	•		
21	8A0089628	1		•	•	•	•	•		
22	8000A3227	1	EV 02 EV 03	•	•					
22	8000A3227	1	Euro 2	•	•					
22	8000A3227	1	2			•	•	•		
23	800053724	1		•	•	•	•	•		
24	8B0089516	1		•	•	•	•	•		
25	8000A2762	1	Euro 2	•	•					

- 2**
- Con questo particolare, ordinare anche:
 - In addition to this part, you have to order the following:
 - Avec cette pièce, il est nécessaire de commander les pièces suivantes:
 - Mit dieser Teil, du brauchst bestellen diese Teile:
 - Con esta pieza, es necesario pedir las siguientes piezas:

N° 8000A2762 - Qt. 1 / N° 8000A3226 - Qt. 2.



F06

3



IMPIANTO ELETTRICO
ELECTRIC SYSTEM • INSTALLATION ÉLECTRIQUE
ELEKTRISCHE ANLAGE • INSTALACIÓN ELÉCTRICA

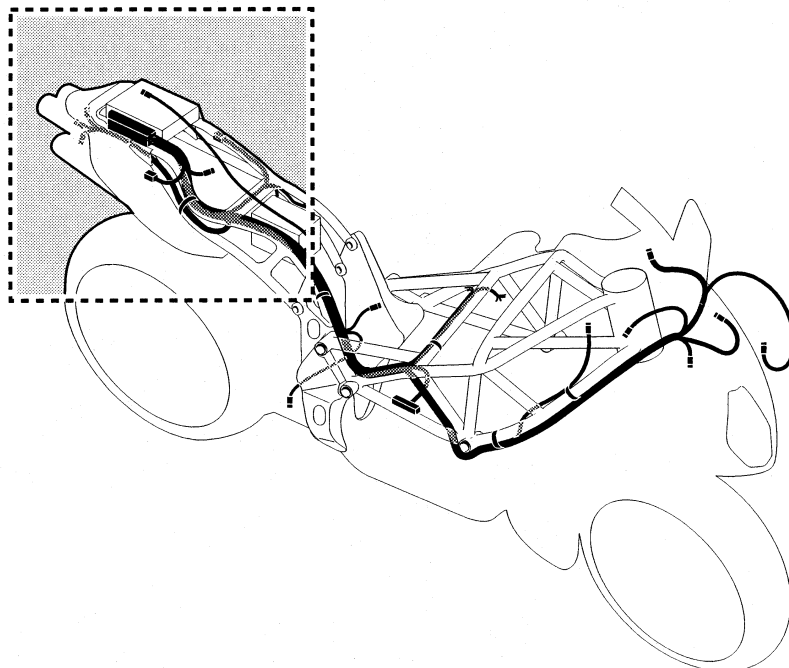
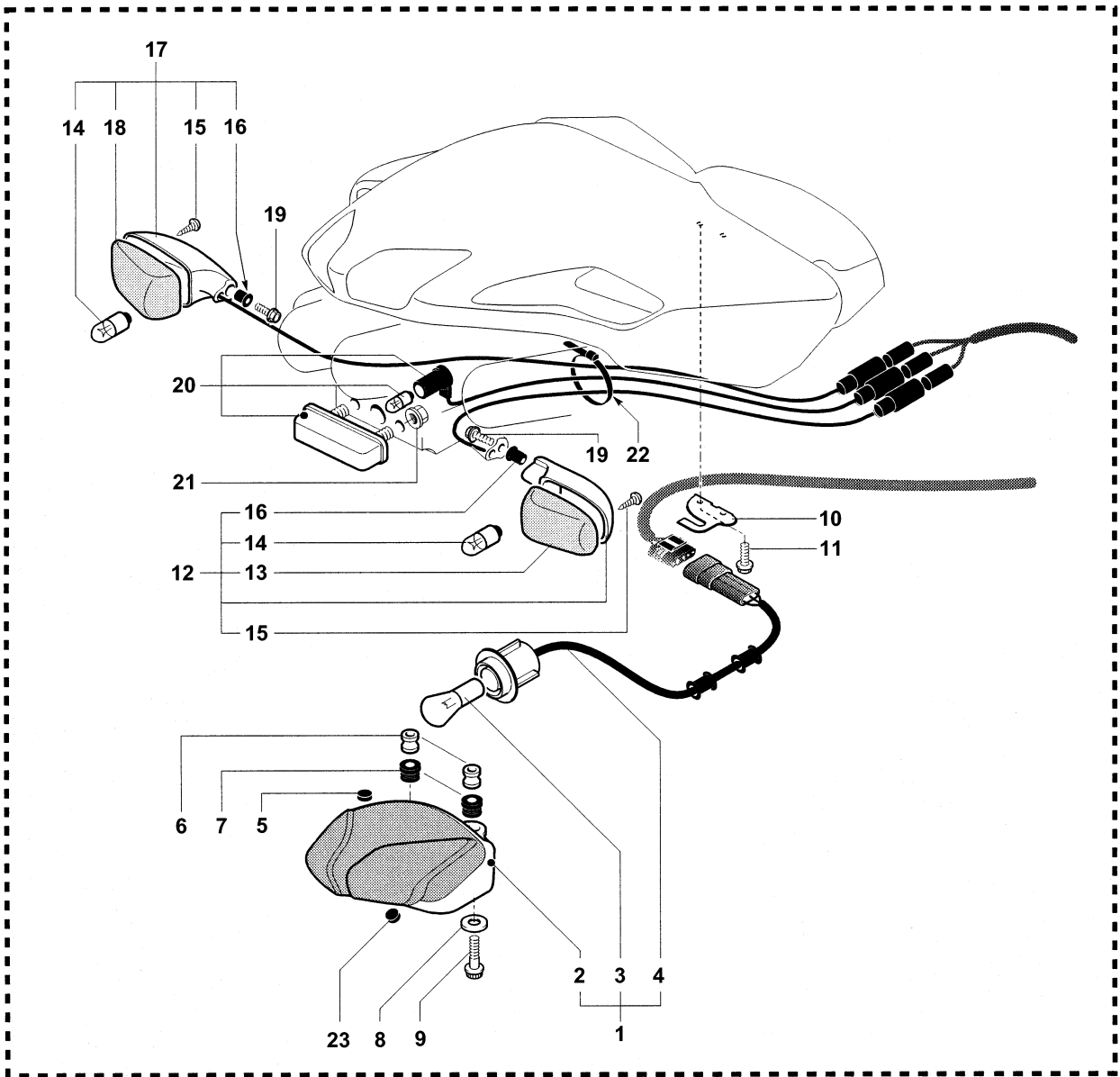



N.	Code	Q.ty	Note	750 S	750 S 1+1	SPR	SR-SR1+1	SENNA	► I FRAME I ►	► I ENGINE I ►
1	800090369	1		•	•	•	•	•		
2	800093335	1		•	•	•	•	•		
3	8A0018246	1		•	•	•	•	•		
4	8A0091696	1		•	•	•	•	•		
5	800090979	1		•		•		•		
5	800095500	1			•					
5	800090979	1	①				•			
5	800095500	1	②				•			
6	800090415	2		•	•	•	•	•		
7	800090239	2		•	•	•	•	•		
8	800056359	2		•	•	•	•	•		
9	8J0090425	2		•	•	•	•	•		
10	800091653	1		•	•	•	•	•		
11	8AA059572	1		•	•	•	•	•		
12	800090372	1		•	•	•	•	•		
13	800093336	1		•	•	•	•	•		
14	800036726	2		•	•	•	•	•		
15	800093416	2		•	•	•	•	•		
16	800048245	2		•	•	•	•	•		
17	800090373	1		•	•	•	•	•		
18	800093337	1		•	•	•	•	•		
19	800062728	2		•	•	•	•	•		
20	800092185	1		•	•	•	•	•		
21	800056443	2		•	•	•	•	•		
22	800092661	1		•	•	•	•	•		
23	800090979	1		•		•		•		
23	8A0095500	1			•					
23	800090979	1	①				•			
23	8A0095500	1	②				•			

- ① Solo per versione monoposto (F4 SR) - Only for single-seater version (F4 SR) - Seulement pour la version monoplace (F4 SR) - Nur für einsitzer Version (F4 SR) - Solamente para la versión monoplace (F4 SR).
- ② Solo per versione biposto (F4 SR 1+1) - Only for two-seater version (F4 SR 1+1) bikes - Seulement pour la version biplace (F4 SR 1+1) - Nur für zweisitzer Version (F4 SR 1+1) - Solamente para la versión biplaza (F4 SR 1+1).



ASSIEME CARTER MOTORE

CRANKCASE ASSEMBLY • ENSEMBLE CARTER DU MOTEUR
 BAUGRUPPE MOTORGEHÄUSE • CONJUNTO CÁRTER MOTOR

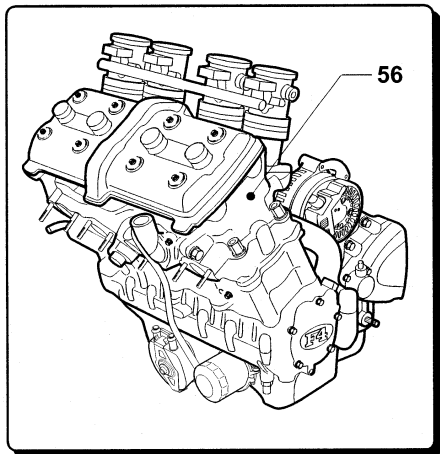
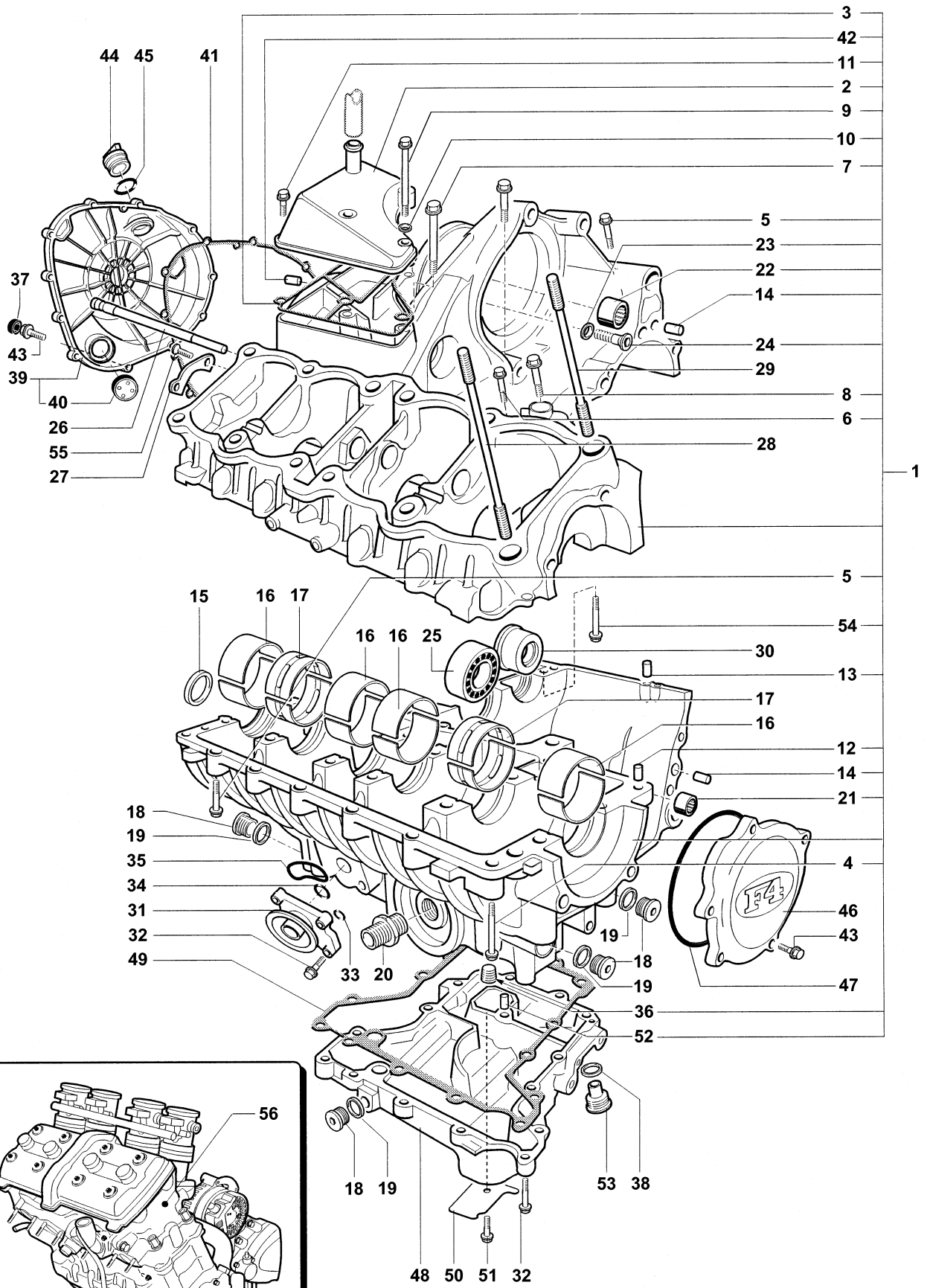

ASSIEME CARTER MOTORE

 CRANKCASE ASSEMBLY • ENSEMBLE CARTER DU MOTEUR
 BAUGRUPPE MOTORGEHÄUSE • CONJUNTO CÁRTER MOTOR

N.	Code	Q.ty	Note	750 S	750 S 1+1	SPR	SR-SR1+1	SENNÀ	► I FRAME I ◄	► I ENGINE I ◄
1	8000A0619	1		•	•	•	•	•		
2	800092465	1		•	•	•	•	•		
3	800087792	1		•	•	•	•	•		
4	800098219	12		•	•	•	•	•		
5	8A0067545	12		•	•	•	•	•		
6	8B0067545	1		•	•	•	•	•		
7	800099476	1		•	•	•	•	•		
8	8A0091697	2		•	•	•	•	•		
9	8V0067545	1		•	•	•	•	•		
10	800064988	1		•	•	•	•	•		
11	800062729	4		•	•	•	•	•		
12	800007719	3		•	•	•	•	•		
13	8A0051549	1		•	•	•	•	•		
14	800086119	3		•	•	•	•	•		
15	800081412	1		•	•	•	•	•		
16	800081317	8	①	•	•	•	•	•		
16	8A0081317	8	②	•	•	•	•	•		
16	8B0081317	8	③	•	•	•	•	•		
17	800081316	4	①	•	•	•	•	•		
17	8A0081316	4	②	•	•	•	•	•		
17	8B0081316	4	③	•	•	•	•	•		
18	800089425	4		•	•	•	•	•		
19	800089426	4		•	•	•	•	•		
20	800081409	1		•	•	•	•	•		
21	800087300	1		•	•	•	•	•		
22	800081422	1		•	•	•	•	•		
23	800086737	1		•	•	•	•	•		
24	800028327	1		•	•	•	•	•		
25	800098404	1	EV 02 / EV 03	•	•					
25	800098405	1	Euro 2	•	•					
25	800098404	1				•	•	•		
26	800089440	1		•	•	•	•	•		
27	800081413	1		•	•	•	•	•		
28	800081418	6		•	•	•	•	•		
29	800081419	6		•	•	•	•	•		
30	800081424	1	EV 02 / EV 03	•	•					
30	8000A1087	1	Euro 2	•	•					
30	800081424	1				•	•	•		
31	800092470	1		•	•	•	•	•		
32	800062730	15		•	•	•	•	•		
32	800062730	4		•	•	•	•	•		
33	8A0031106	1		•	•	•	•	•		
34	800023116	1		•	•	•	•	•		
35	800040872	1		•	•	•	•	•		
36	800069769	1		•	•	•	•	•		
37	800094896	1		•	•	•	•	•		
38	62N015682	1		•	•	•	•	•		
39	800092467	1	EV 02	•	•					
39	800099105	1	EV 03 / Euro 2	•	•					
39	800099105	1				•	•			
39	800092467	1						•		
40	800073529	1		•	•	•	•	•		
41	800080691	1		•	•	•	•	•		
42	8C0019590	2		•	•	•	•	•		
43	800062728	16		•	•	•	•	•		



- ①** Semicuscinetto rosso • Red half bearing • Demi-coussinet rouge • Halblager rot • Semicojinete rojo
② Semicuscinetto blu • Blue half bearing • Demi-coussinet bleu • Halblager blau • Semicojinete azul
③ Semicuscinetto giallo • Yellow half bearing • Demi-coussinet jaune • Halblager gelb • Semicojinete amarillo

G01

3



ASSIEME CARTER MOTORE

CRANKCASE ASSEMBLY • ENSEMBLE CARTER DU MOTEUR
 BAUGRUPPE MOTORGEHÄUSE • CONJUNTO CÁRTER MOTOR

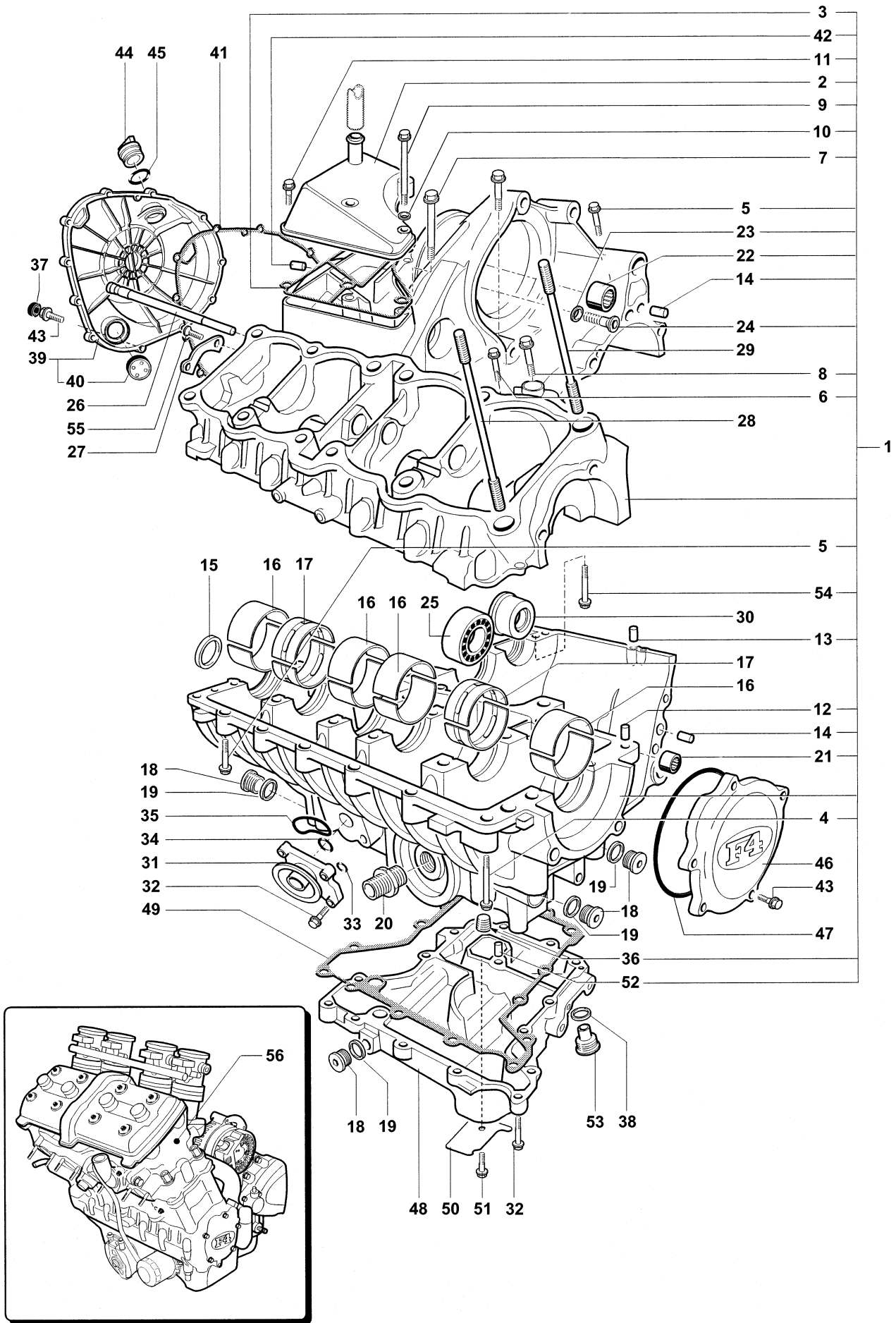

ASSIEME CARTER MOTORE

 CRANKCASE ASSEMBLY • ENSEMBLE CARTER DU MOTEUR
 BAUGRUPPE MOTORGEHÄUSE • CONJUNTO CÁRTER MOTOR



N.	Code	Q.ty	Note	750 S	750 S 1+1	SPR	SR-SR1+1	SENNÀ	► I FRAME I ◄	► I ENGINE I ◄
44	800092473	1		•	•	•	•	•		
45	8A0023120	1		•	•	•	•	•		
46	800086728	1	EV 02	•	•					
46	80A086728	1	EV 03 / Euro 2	•	•					
46	80A086728	1				•	•			
46	800086728	1						•		
47	800094626	1		•	•	•	•	•		
48	800092469	1		•	•	•	•	•		
49	800087786	1		•	•	•	•	•		
50	800089422	1		•	•	•	•	•		
51	800062725	1		•	•	•	•	•		
52	800007719	2		•	•	•	•	•		
53	800096747	1		•	•	•	•	•		
54	8B0067545	1	EV 02	•	•					
54	60N402562	1	EV 03 / Euro 2	•	•					
54	60N402562	1				•	•			
54	8B0067545	1						•		
55	800060577	2		•	•	•	•	•		
56	800099041	1	EV 02 / EV 03	•	•					
56	8000A3381	1	Euro 2	•	•					
56	8000A1287	1				•	•			
56	800098468	1						•		



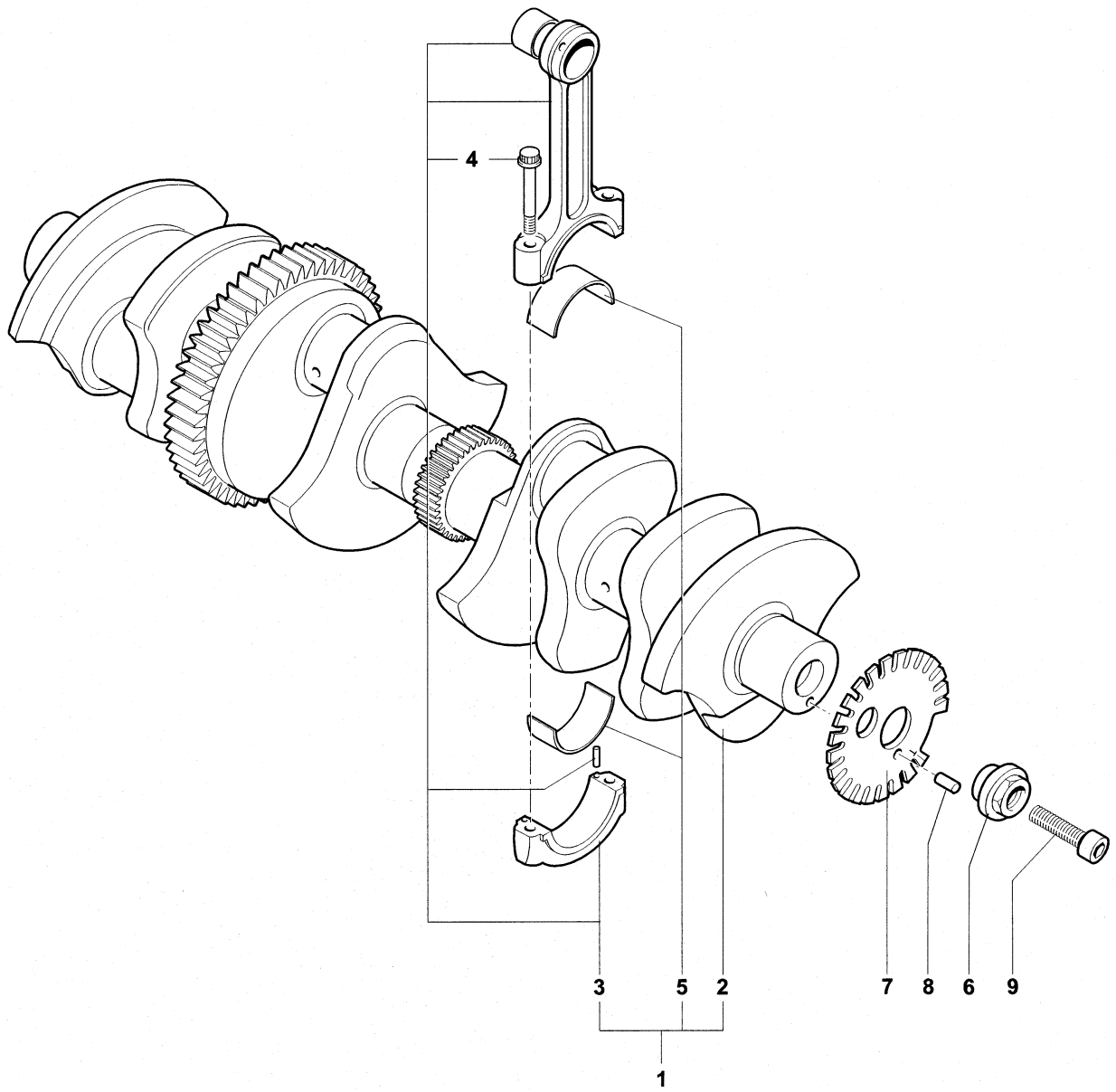

ASSIEME ALBERO MOTORE

ENGINE CRANKCASE ASSEMBLY • ENSEMBLE VILEBREQUIN
BAUGRUPPE KURBELWELLE • CONJUNTO CIGÜEÑAL



ASSIEME ALBERO MOTORE

 ENGINE CRANKCASE ASSEMBLY • ENSEMBLE VILEBREQUIN
 BAUGRUPPE KURBELWELLE • CONJUNTO CIGÜEÑAL

N.	Code	Q.ty	Note	750 S	750 S 1+1	SPR	SR-SR1+1	SENNÁ	► I FRAME I ►	► I ENGINE I ►
1	800091897	1		•	•	•	•	•		
2	800091898	1		•	•	•	•	•		
3	800091899	4	EV 02 / EV 03	•	•					
3	8000A3026	4	Euro 2	•	•					
3	800091899	4				•	•	•		
4	800085068	8		•	•	•	•	•		
5	800081315	8	❶	•	•	•	•	•		
5	8A0081315	8	❷	•	•	•	•	•		
5	8B0081315	8	❸	•	•	•	•	•		
6	800086727	1		•	•	•	•	•		
7	800086726	1		•	•	•	•	•		
8	800019971	1		•	•	•	•	•		
9	60N102558	1		•	•	•	•	•		

- ❶ Semicuscinetto rosso • Red half bearing • Demi-coussinet rouge • Halblager rot • Semicojinete rojo
 ❷ Semicuscinetto blu • Blue half bearing • Demi-coussinet bleu • Halblager blau • Semicojinete azul
 ❸ Semicuscinetto giallo • Yellow half bearing • Demi-coussinet jaune • Halblager gelb • Semicojinete amarillo



ASSIEME CILINDRI E PISTONE

DRIVING SHAFT ASSEMBLY • ENSEMBLE CYLINDRES ET PISTON

BAUGRUPPE ZYLINDER UND KOLBEN • CONJUNTO CILINDROS Y PISTONES

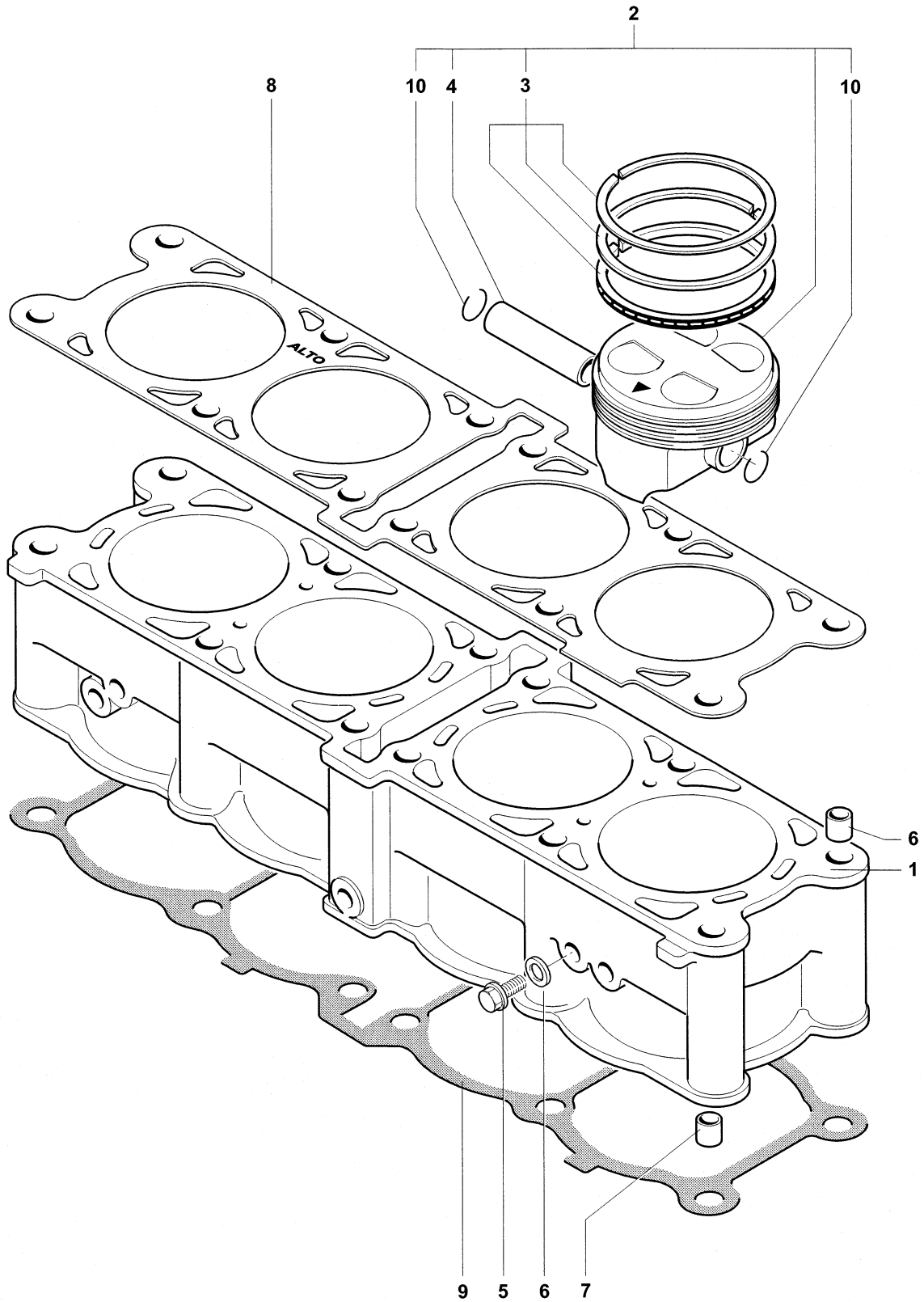

ASSIEME CILINDRI E PISTONE

DRIVING SHAFT ASSEMBLY • ENSEMBLE CYLINDRES ET PISTON

BAUGRUPPE ZYLINDER UND KOLBEN • CONJUNTO CILINDROS Y PISTONES



N.	Code	Q.ty	Note	750 S	750 S 1+1	SPR	SR-SR1+1	SENNA	► I FRAME I ►	► I ENGINE I ►
1	800098020	1		•	•	•	•	•		
2	800098021	4		•	•			•		
2	8000A1345	4				•	•			
3	800098023	4		•	•	•	•	•		
4	800098027	4		•	•	•	•	•		
5	800081536	2		•	•	•	•	•		
6	800064988	2		•	•	•	•	•		
7	800081535	4		•	•	•	•	•		
8	800098679	1	≠ 1.45	•	•	•	•	•		
8	8A0098679	1	≠ 1.30	•	•	•	•	•		
8	8B0098679	1	≠ 1.20	•	•	•	•	•		
9	800087771	1		•	•	•	•	•		
10	800098028	8		•	•	•	•	•		



ASSIEME TESTATA
CYLINDER HEAD ASSEMBLY • ENSEMBLE CULASSE
BAUGRUPPE ZYLINDERKOPF • CONJUNTO CULATA

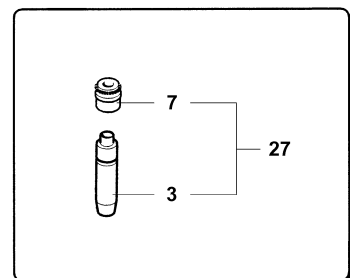
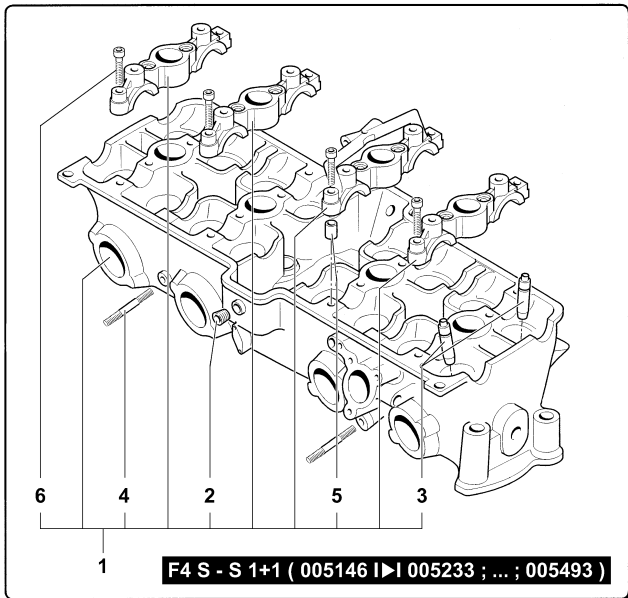
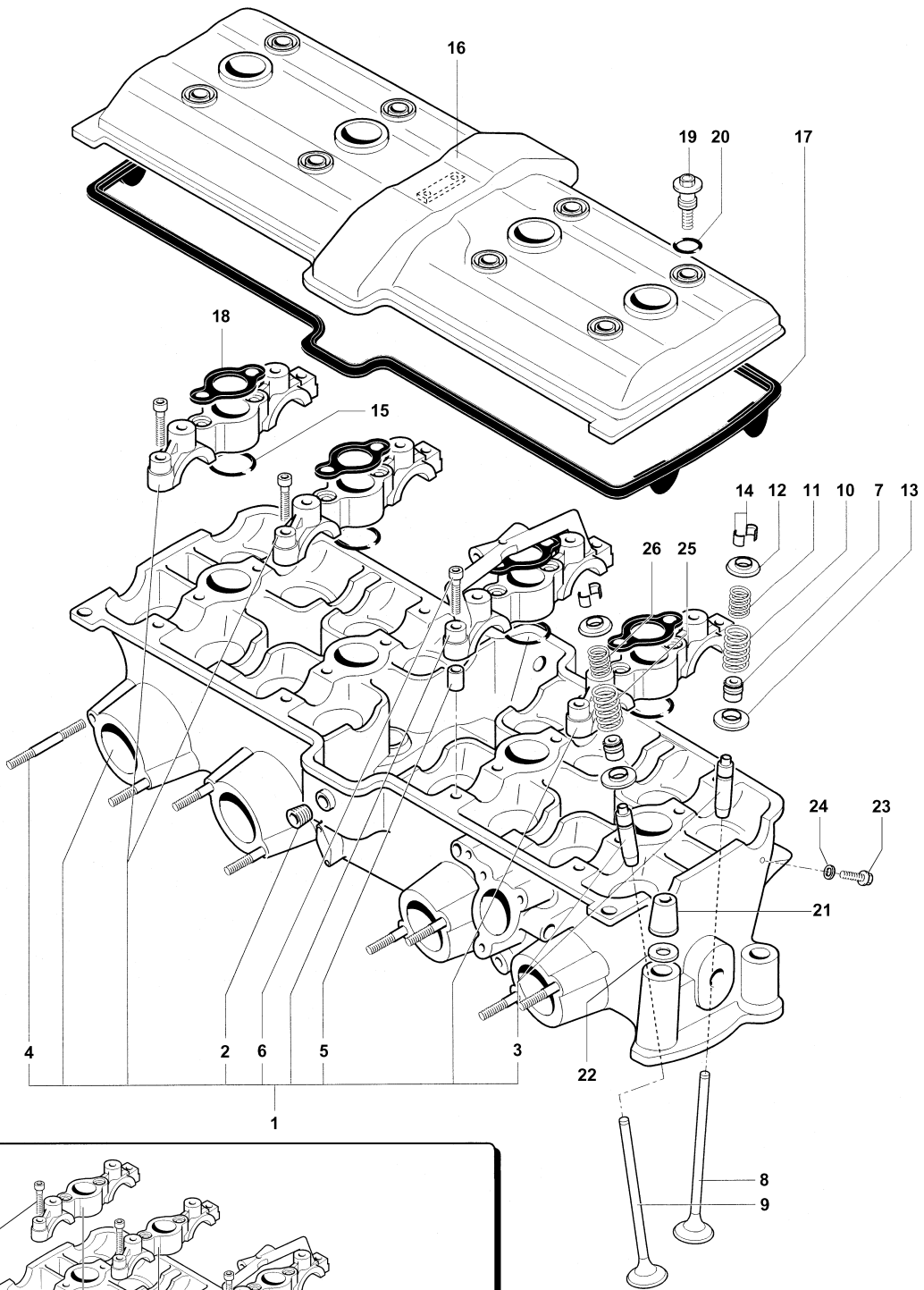

ASSIEME TESTATA

 CYLINDER HEAD ASSEMBLY • ENSEMBLE CULASSE
 BAUGRUPPE ZYLINDERKOPF • CONJUNTO CULATA

N.	Code	Q.ty	Note	750 S	750 S 1+1	SPR	SR-SR1+1	SENNÀ	► I FRAME I ►	► I ENGINE I ►
1	800099497	1		•	•				► I 005145 005234 I ► ► I 005237 005261 I ► ► I 005432 005470 I ► ► I 005492 005494 I ►	
1	800097250	1		•	•				005146 I ► ► I 005233 005238 I ► ► I 005260 005433 I ► ► I 005469 005493	
1	8000A3385	1	Euro 2	•	•					
1	8000A1340	1				•	•			
1	800099497	1						•		
2	800069769	7		•	•	•	•	•		
3	8A0081228	16	①	•	•	•	•	•		05952 I ►
3	8B0081228	16	②	•	•	•	•	•		05952 I ►
4	800081276	8		•	•				► I 005145 005234 I ► ► I 005237 005261 I ► ► I 005432 005470 I ► ► I 005492 005494 I ►	
4	800091064	2		•	•				005146 I ► ► I 005233 005238 I ► ► I 005260 005433 I ► ► I 005469 005493	
4	800081276	8				•	•	•		
5	800051549	8		•	•	•	•	•		
6	800085071	16		•	•	•	•	•		
7	800098167	16	③	•	•	•	•	•		► I 05951
7	800065814	16	④	•	•			•		► I 05951
7	800065814	16		•	•	•	•	•		05952 I ►
8	800097918	8		•	•	•	•	•		
9	800097919	8		•	•	•	•	•		
10	800098670	8		•	•			•		
10	8000A1940	8				•	•			
11	800098671	8		•	•			•		
11	8000A1941	8				•	•			
12	8000A3732	16		•	•	•	•	•		
13	8000A3733	16		•	•	•	•	•		
14	800092433	32		•	•	•	•	•		
15	800087752	4		•	•	•	•	•		
16	800092447	1		•	•	•	•	•		

- ①** Maggiorata 0.025 mm • Oversized 0.025 mm • Surdimensionnée 0.025 mm • Übermaß 0.025 mm • Extra grande 0.025 mm.
② Maggiorata 0.05 mm • Oversized 0.05 mm • Surdimensionnée 0.05 mm • Übermaß 0.05 mm • Extra grande 0.05 mm.
③ Prima della sostituzione del part. N° 1 o N° 27 • Before replacement of part No. 1 or No. 27 • Avant de le remplacement du pièce N° 1 ou N° 27 • Bevor Wechsel von Teil Nr. 1 oder Nr. 27 • Antes de la sustitución de la pieza N° 1 o N° 27.
④ Dopo la sostituzione del part. N° 1 o N° 27 • After replacement of part No. 1 or No. 27 • Suite à le remplacement du pièce N° 1 ou N° 27 • Nach Wechsel von Teil Nr. 1 oder Nr. 27 • Después de la sustitución de la pieza N° 1 o N° 27.

G04

3



ASSIEME TESTATA
CYLINDER HEAD ASSEMBLY • ENSEMBLE CULASSE
BAUGRUPPE ZYLINDERKOPF • CONJUNTO CULATA

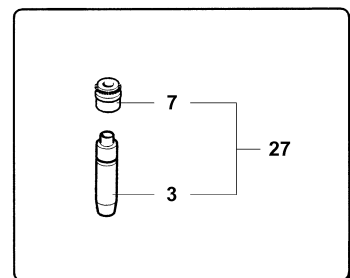
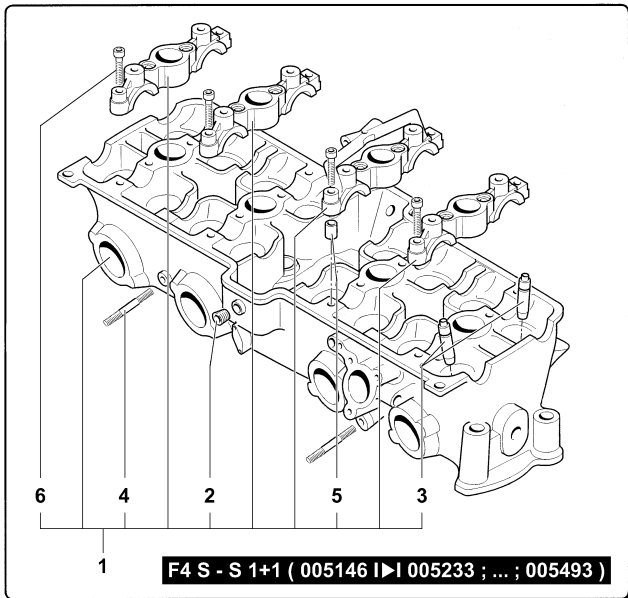
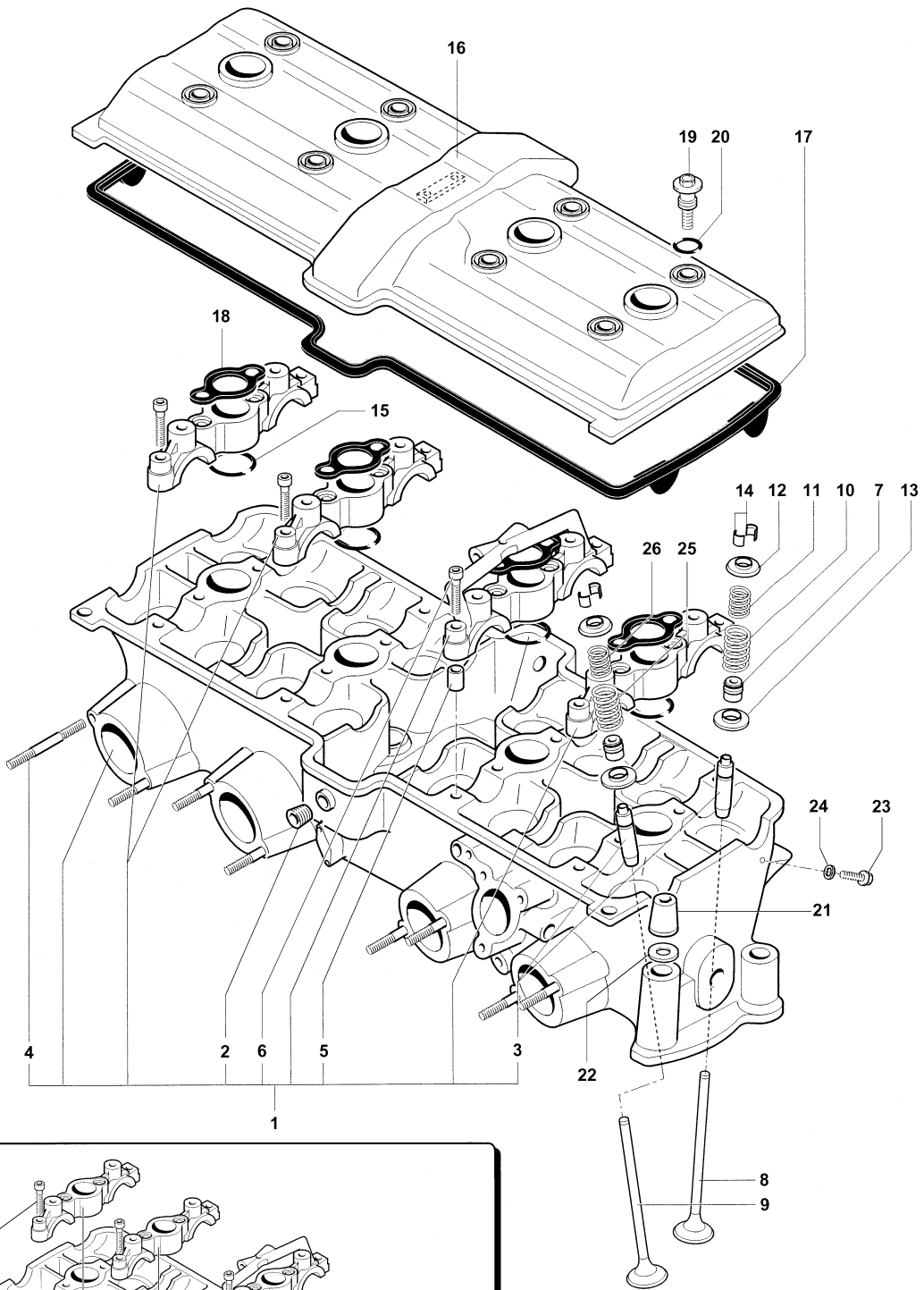

ASSIEME TESTATA

 CYLINDER HEAD ASSEMBLY • ENSEMBLE CULASSE
 BAUGRUPPE ZYLINDERKOPF • CONJUNTO CULATA

N.	Code	Q.ty	Note	750 S	750 S 1+1	SPR	SR-SR1+1	SENNÀ	► I FRAME I ►	► I ENGINE I ►
17	800087756	1		•	•	•	•	•		
18	800087755	4		•	•	•	•	•		
19	800087779	8		•	•	•	•	•		
20	8A0025082	8		•	•	•	•	•		
21	800081547	12		•	•	•	•	•		
22	800069156	12		•	•	•	•	•		
23	8D0067997	4		•	•	•	•	•		► I 08707
24	800036137	4		•	•	•	•	•		► I 08707
25	800098670	8		•	•	•	•	•		
26	800098671	8		•	•	•	•	•		
27	8000A2306	16	①	•	•	•	•	•		
27	8A00A2306	16	②	•	•	•	•	•		



- ① Maggiorata 0.025 mm • Oversized 0.025 mm • Surdimensionnée 0.025 mm • Übermaß 0.025 mm • Extra grande 0.025 mm.
 ② Maggiorata 0.05 mm • Oversized 0.05 mm • Surdimensionnée 0.05 mm • Übermaß 0.05 mm • Extra grande 0.05 mm.

G04

3



DISTRIBUZIONE
TIMING SYSTEM • DISTRIBUTION
VENTILSTEUERUNG • DISTRIBUCIÓN

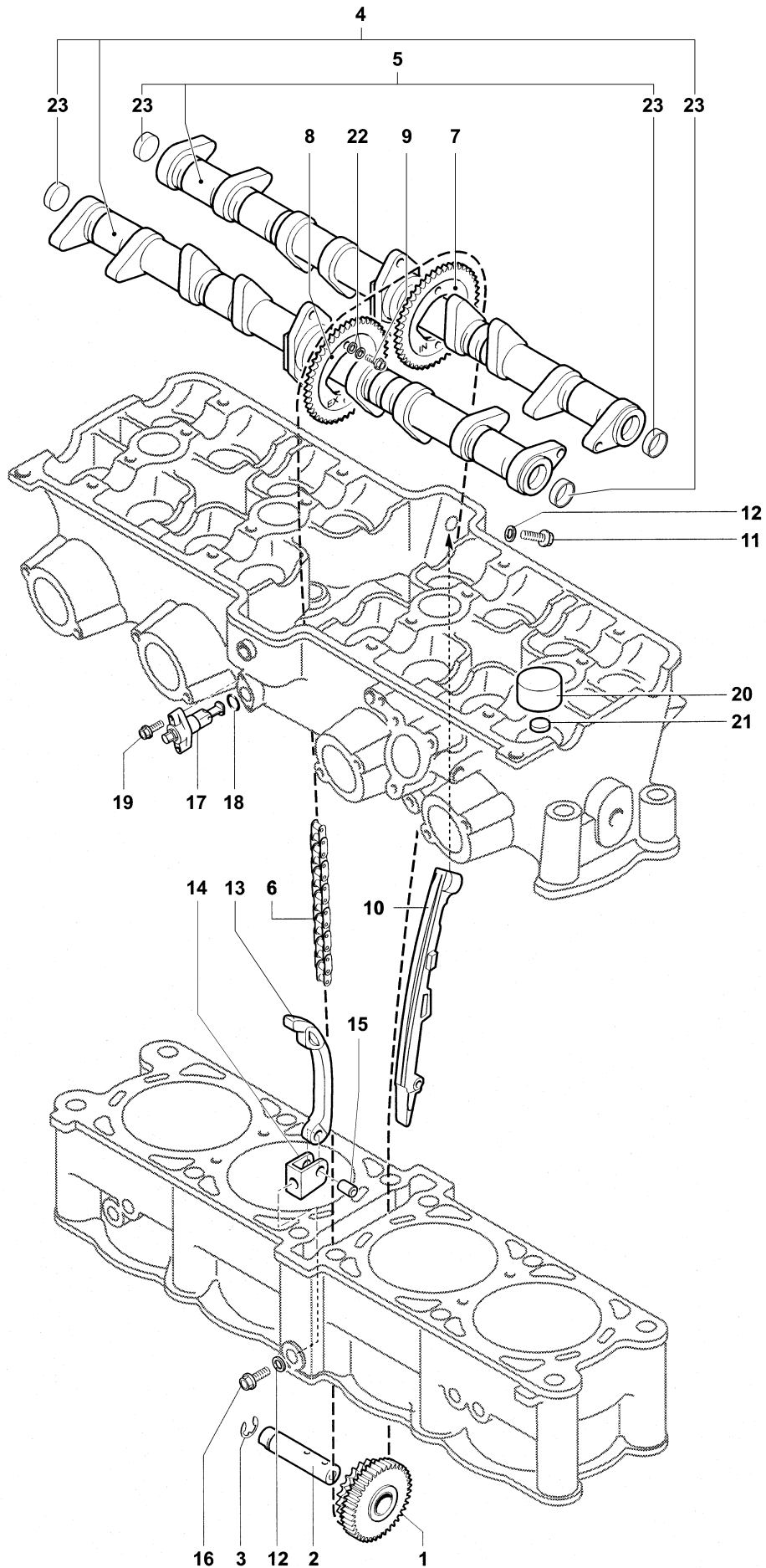



N.	Code	Q.ty	Note	750 S	750 S 1+1	SPR	SR-SR1+1	SENNA	► I FRAME I ►	► I ENGINE I ►
1	800089445	1		•	•	•	•	•		
2	800081261	1		•	•	•	•	•		
3	66N021313	1		•	•	•	•	•		
4	8000A0781	1		•	•			•		
4	8000A1349	1				•	•			
5	800087781	1		•	•			•		
5	8000A1348	1				•	•			
6	8000A0120	1	①	•	•	•	•	•		
6	800096598	1	②	•	•	•	•	•		
7	800098931	1	EV 02 / EV 03	•	•					
7	8000A4301	1	Euro 2	•	•					
7	8000A2591	1				•	•			
7	800098931	1						•		
8	8000A0780	1	EV 02 / EV 03	•	•					
8	8000A4302	1	Euro 2	•	•					
8	8000A2592	1				•	•			
8	8000A0780	1						•		
9	800062726	4	EV 02 / EV 03	•	•					
9	8C0085071	4	Euro 2	•	•					
9	800062726	4				•	•	•		
10	800081552	1		•	•	•	•	•		
11	800062728	1		•	•	•	•	•		
12	800064988	2		•	•	•	•	•		
13	800086735	1		•	•	•	•	•		
14	800087784	1		•	•	•	•	•		
15	800087785	1		•	•	•	•	•		
16	800062727	1		•	•	•	•	•		
17	800091895	1		•	•	•	•	•		
18	800018422	1		•	•	•	•	•		
19	800062729	2		•	•	•	•	•		
20	800092456	16		•	•			•		
20	8000A1839	16				•	•			
21	800084182	16	≠ 1.60	•	•	•	•	•		
21	8A0084182	16	≠ 1.65	•	•	•	•	•		
21	8B0084182	16	≠ 1.70	•	•	•	•	•		
21	8C0084182	16	≠ 1.75	•	•	•	•	•		
21	8D0084182	16	≠ 1.80	•	•	•	•	•		
21	8E0084182	16	≠ 1.85	•	•	•	•	•		
21	8F0084182	16	≠ 1.90	•	•	•	•	•		
21	8G0084182	16	≠ 1.95	•	•	•	•	•		
21	8H0084182	16	≠ 2.00	•	•	•	•	•		
21	8J0084182	16	≠ 2.05	•	•	•	•	•		
21	8K0084182	16	≠ 2.10	•	•	•	•	•		
21	8L0084182	16	≠ 2.15	•	•	•	•	•		
21	8M0084182	16	≠ 2.20	•	•	•	•	•		
21	8N0084182	16	≠ 2.25	•	•	•	•	•		
21	8P0084182	16	≠ 2.30	•	•	•	•	•		
21	8R0084182	16	≠ 2.35	•	•	•	•	•		
21	8S0084182	16	≠ 2.40	•	•	•	•	•		
21	8T0084182	16	≠ 2.45	•	•	•	•	•		
21	8U0084182	16	≠ 2.50	•	•	•	•	•		
21	8V0084182	16	≠ 2.55	•	•	•	•	•		
21	8W0084182	16	≠ 2.60	•	•	•	•	•		
22	8000A3486	4	Euro 2	•	•					
23	8B0057196	4		•	•	•	•	•		

- ① Catena di distribuzione chiusa - Timing chain closed - Chaîne de distribution fermée - Ventilsteuerkette geschlossen - Cadena de distribución cerrada
 ② Catena di distribuzione aperta - Timing chain open - Chaîne de distribution ouverte - Ventilsteuerkette offen - Cadena de distribución abierta



LUBRIFICAZIONE
LUBRICATION SYSTEM • GRAISSAGE
SCHMIERSYSTEM • LUBRIFICACIÓN

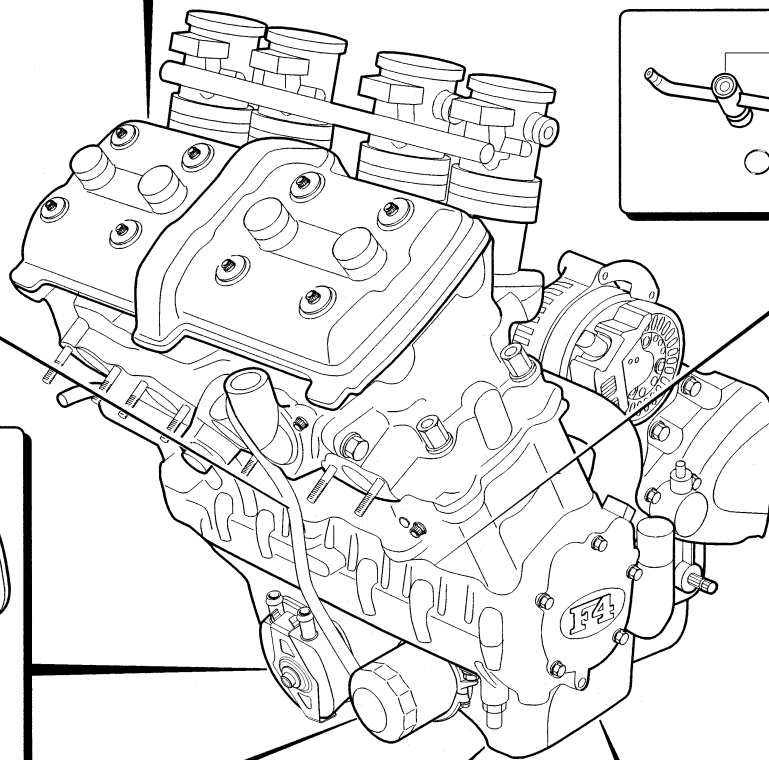
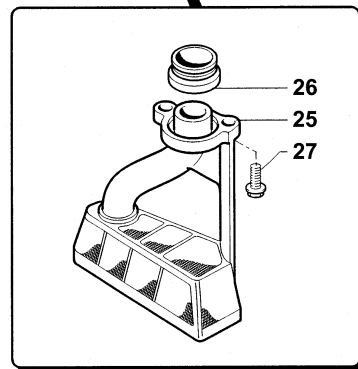
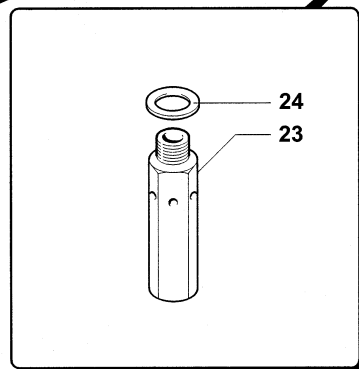
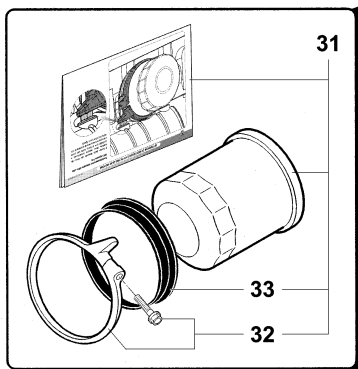
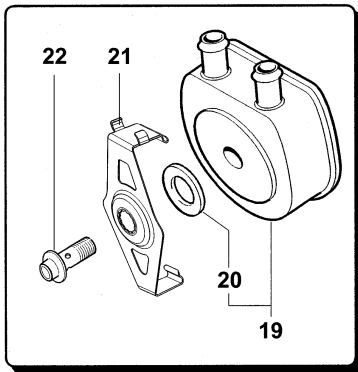
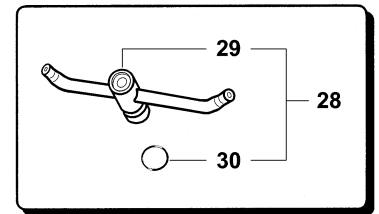
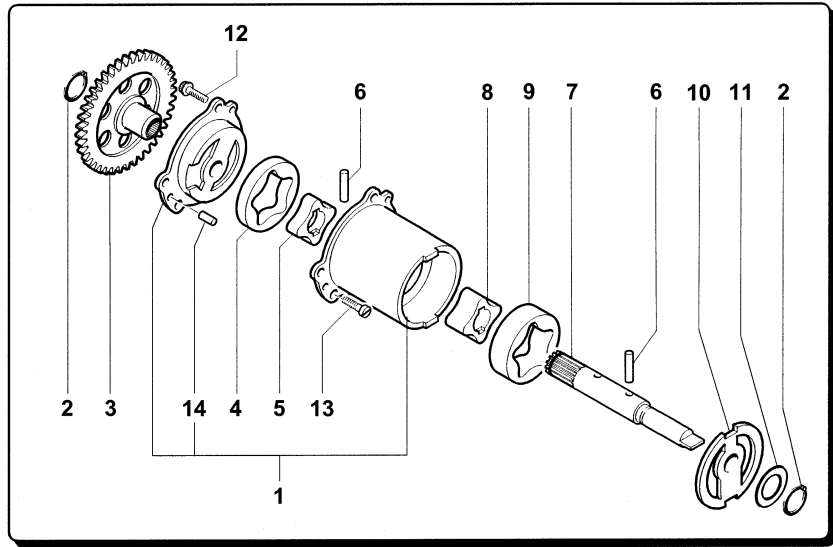
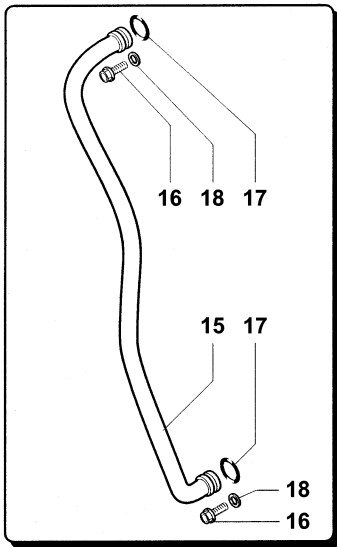



N.	Code	Q.ty	Note	750 S	750 S 1+1	SPR	SR-SR1+1	SENNÀ	► I FRAME I ◄	► I ENGINE I ◄
1	800086201	1		•	•	•	•	•		
2	66N021203	2		•	•	•	•	•		
3	800081357	1		•	•	•	•	•		
4	800081364	1		•	•	•	•	•		
5	800081365	1		•	•	•	•	•		
6	800019590	2		•	•	•	•	•		
7	800080701	1		•	•	•	•	•		
8	800081363	1		•	•	•	•	•		
9	800081362	1		•	•	•	•	•		
10	800081443	1		•	•	•	•	•		
11	8D0009408	1		•	•	•	•	•		
12	800062728	3		•	•	•	•	•		
13	800035408	1		•	•	•	•	•		
14	800038520	2		•	•	•	•	•		
15	800096738	1		•	•	•	•	•		
16	800062726	2		•	•	•	•	•		
17	800023108	2		•	•	•	•	•		
18	800095505	2		•	•	•	•	•		
19	800089434	1		•	•	•	•	•		
20	800092478	1		•	•	•	•	•		
21	8000A1544	1		•	•	•	•	•		
22	800099459	1		•	•	•	•	•		
23	800086132	1		•	•	•	•	•		
24	800047763	1		•	•	•	•	•		
25	800080689	1		•	•	•	•	•		
26	800080695	1		•	•	•	•	•		
27	800062728	2		•	•	•	•	•		
28	800091915	2		•	•	•	•	•		
29	800091914	2		•	•	•	•	•		
30	800023106	2		•	•	•	•	•		
31	8000A3702	1		•	•	•	•	•		
32	8000A1488	1		•	•	•	•	•		
33	8000A3281	1		•	•	•	•	•		



POMPA ACQUA
WATER PUMP • POMPE À EAU
WASSERPUMPE • BOMBA AGUA

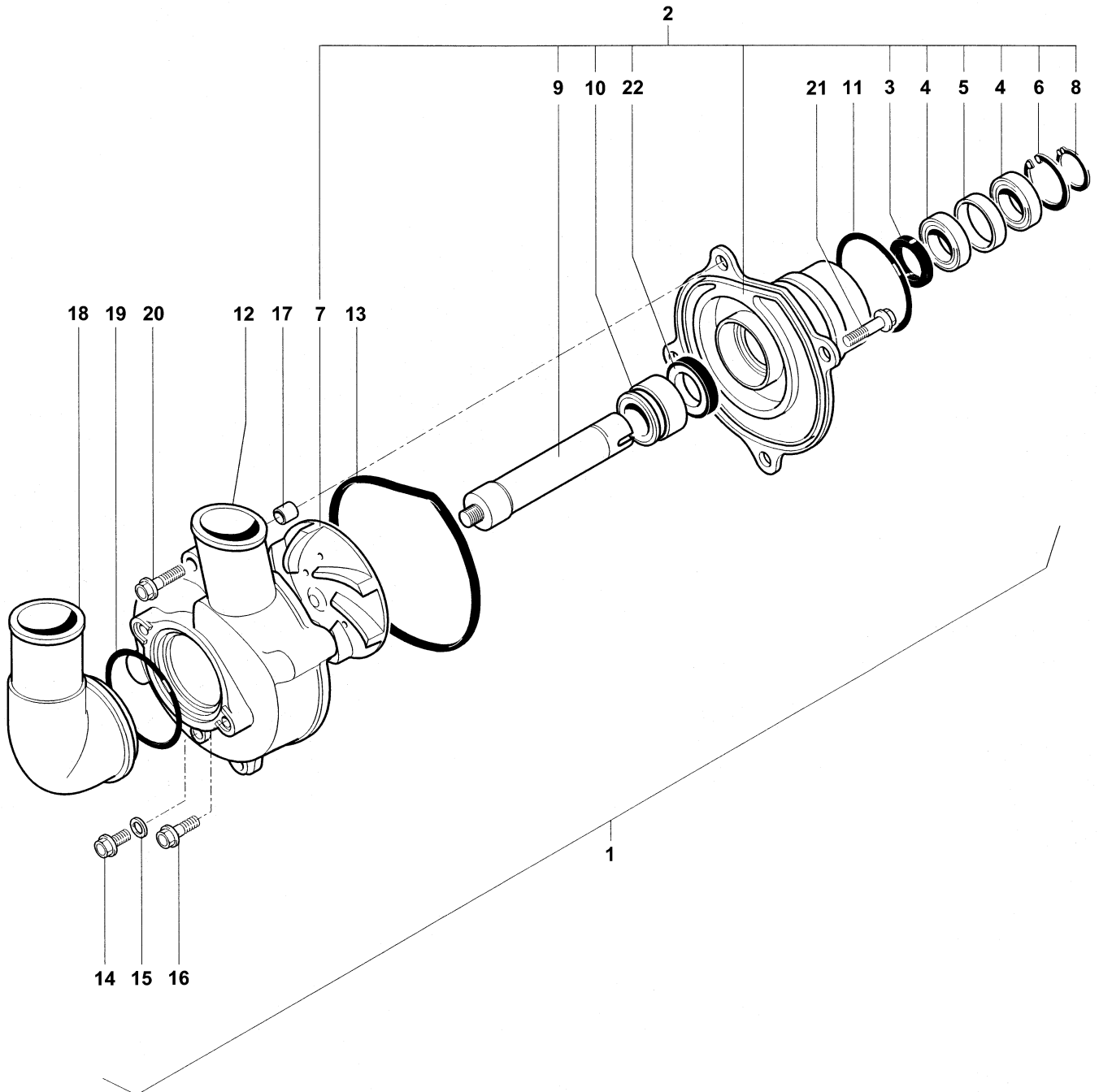



N.	Code	Q.ty	Note	750 S	750 S 1+1	SPR	SR-SR1+1	SENNÀ	► I FRAME I ◄	► I ENGINE I ◄
1	800089427	1		•	•	•	•	•		
2	800089428	1		•	•	•	•	•		
3	8A0028855	1		•	•	•	•	•		
4	800034317	2		•	•	•	•	•		
5	800081239	1		•	•	•	•	•		
6	66N221262	1		•	•	•	•	•		
7	800081538	1		•	•	•	•	•		
8	66N221202	1		•	•	•	•	•		
9	800081539	1		•	•	•	•	•		
10	800081236	1		•	•	•	•	•		
11	800035809	1		•	•	•	•	•		
12	800089412	1		•	•	•	•	•		
13	800086702	1		•	•	•	•	•		
14	800081536	1		•	•	•	•	•		
15	800064988	1		•	•	•	•	•		
16	800062727	2		•	•	•	•	•		
17	800051549	2		•	•	•	•	•		
18	800089405	1		•	•	•	•	•		
19	800017679	1		•	•	•	•	•		
20	8A0067545	2		•	•	•	•	•		
21	800062727	2		•	•	•	•	•		
22	800081237	1		•	•	•	•	•		



IMPIANTO DI RAFFREDDAMENTO
COOLING SYSTEM • CIRCUIT DE REFRIGERISSEMENT
KÜHLSYSTEM • INSTALACIÓN DE REFRIGERACIÓN

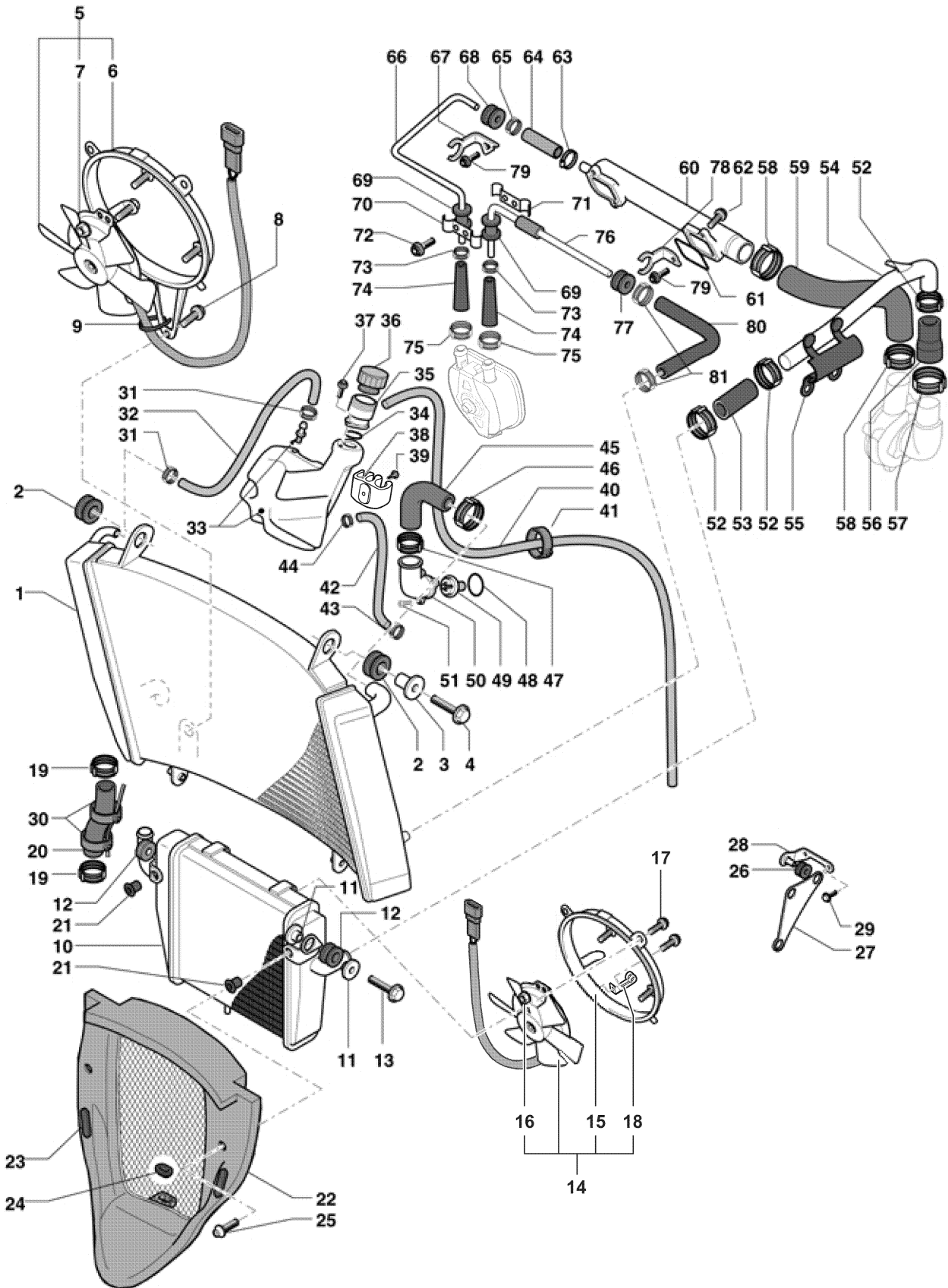

IMPIANTO DI RAFFREDDAMENTO
 COOLING SYSTEM • CIRCUIT DE REFROIDISSEMENT
 KÜHLSYSTEM • INSTALACIÓN DE REFRIGERACIÓN



N.	Code	Q.ty	Note	750 S	750 S 1+1	SPR	SR-SR1+1	SENNA	► I FRAME I ►	► I ENGINE I ►
1	800084917	1		•	•	•	•	•		
2	800094517	2		•	•	•	•	•		
3	800062652	1		•	•	•	•	•		
4	800062728	1		•	•	•	•	•		
5	800095489	1		•	•	•	•	•		
6	800095490	1		•	•	•	•	•		
7	800042278	3		•	•	•	•	•		
8	800062725	3		•	•	•	•	•		
9	800092661	1		•	•	•	•	•		
10	800084918	1		•	•	•	•	•		
11	800090943	2		•	•	•	•	•		
12	800062651	2		•	•	•	•	•		
13	800062729	1		•	•	•	•	•		
14	800084919	1		•	•	•	•	•		
15	800084934	1		•	•	•	•	•		
16	800042278	3		•	•	•	•	•		
17	800062725	4		•	•	•	•	•		
18	8000A1792	1		•	•	•	•	•		
19	8G0092249	2		•	•	•	•	•		
20	800091031	1		•	•	•	•	•		
21	800048245	2		•	•	•	•	•		
22	800095482	1		•	•	•	•	•		
23	800095804	2		•	•	•	•	•		
24	800041874	1		•	•	•	•	•		
25	800089786	2		•	•	•	•	•		
26	800089293	3		•	•	•	•	•		
27	800091029	1		•	•	•	•	•		
28	800095494	1		•	•	•	•	•		
29	800062726	2		•	•	•	•	•		
30	800092247	2		•	•	•	•	•		
31	800092256	2		•	•	•	•	•		
32	800090245	1		•	•	•	•	•		
33	800098943	1		•	•				005207 I ► ► I 005234 005237 I ► ► I 005292 005463 I ► ► I 005483 005493 I ► ► I 005503 005583 I ► ► I 005702 005713 I ► ► I 005728	
33	800098943	1	①	•	•				► I 005208 005233 I ► ► I 005238 005291 I ► ► I 005464 005482 I ► ► I 005494 005502 I ► ► I 005584 005701 I ► ► I 005712 005727 I ►	

- ① • Con questo particolare, ordinare anche:
 • In addition to this part, you have to order the following:
 • Avec cette pièce, il est nécessaire de commander les pièces suivantes:

- Mit dieser Teil, du brauchst bestellen diese Teile:
 • Con esta pieza, es necesario pedir las siguientes piezas:

N° 800097884 - Qt. 1 / N° 8B0066778 - Qt. 1.



G08

2



IMPIANTO DI RAFFREDDAMENTO
COOLING SYSTEM • CIRCUIT DE REFRIGERISSEMENT
KÜHLSYSTEM • INSTALACIÓN DE REFRIGERACIÓN

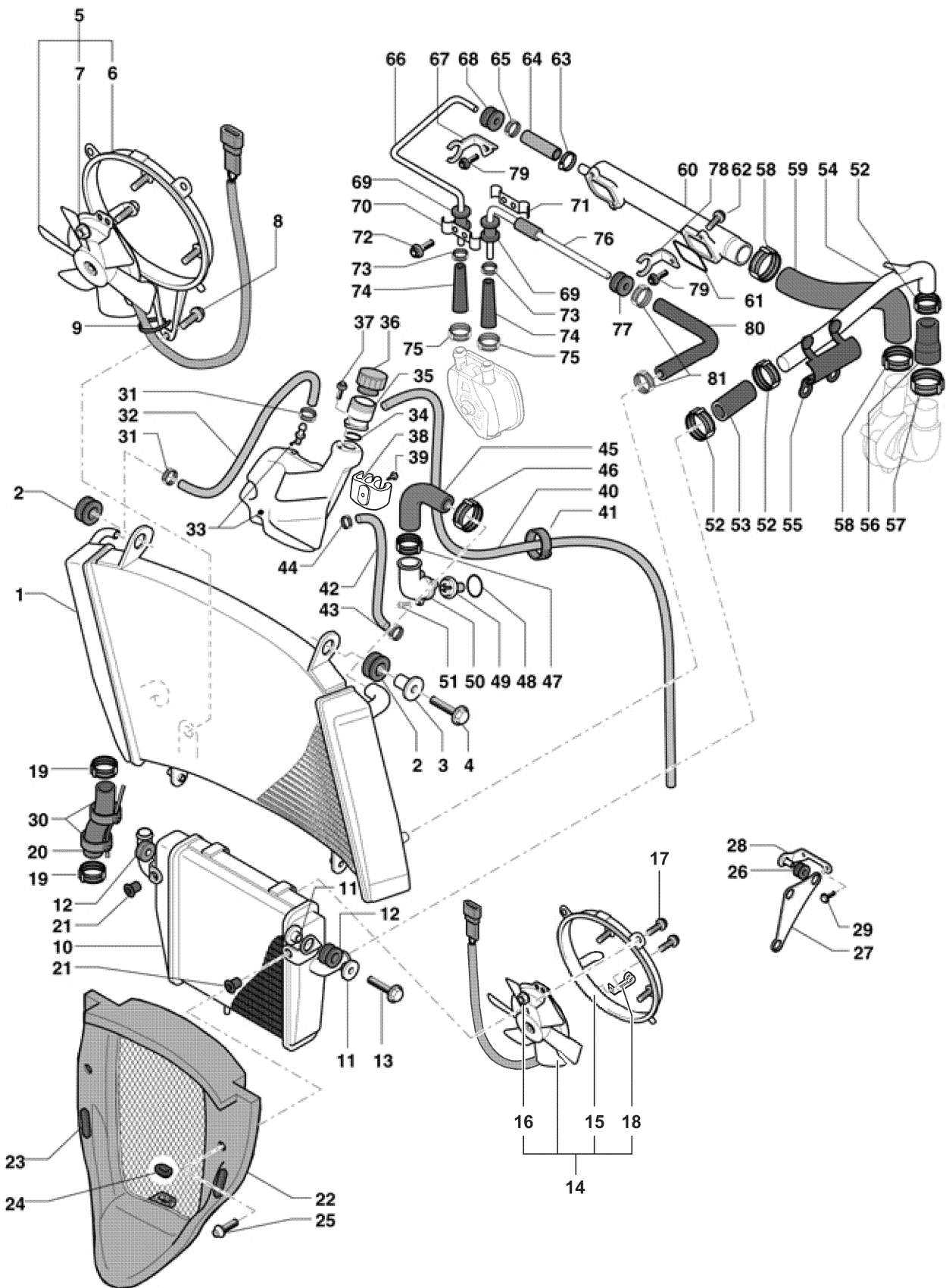

IMPIANTO DI RAFFREDDAMENTO
 COOLING SYSTEM • CIRCUIT DE REFRROIDISSEMENT
 KÜHLSYSTEM • INSTALACIÓN DE REFRIGERACIÓN



N.	Code	Q.ty	Note	750 S	750 S 1+1	SPR	SR-SR1+1	SENNÀ	► I FRAME I ►	► I ENGINE I ►
33	800098943	1				•	•			
33	800098943	1	②					•		
34	800090945	1		•	•	•	•	•		
35	8A0090944	1		•	•	•	•	•		
36	800091707	1		•	•	•	•	•		
37	8C0090424	2		•	•	•	•	•		
38	800097884	1		•	•				005207 I ► ► I 005234 005237 I ► ► I 005292 005463 I ► ► I 005483 005493 I ► ► I 005503 005583 I ► ► I 005702 005713 I ► ► I 005728	
38	800090988	1		•	•				► I 005208 005233 I ► ► I 005238 005291 I ► ► I 005464 005482 I ► ► I 005494 005502 I ► ► I 005584 005701 I ► ► I 005712 005727 I ►	
38	800097884	1				•	•			
38	800090988	1						•		
39	8B0066778	1		•	•				005207 I ► ► I 005234 005237 I ► ► I 005292 005463 I ► ► I 005483 005493 I ► ► I 005503 005583 I ► ► I 005702 005713 I ► ► I 005728	
39	800035408	2		•	•				► I 005208 005233 I ► ► I 005238 005291 I ► ► I 005464 005482 I ► ► I 005494 005502 I ► ► I 005584 005701 I ► ► I 005712 005727 I ►	



- ② • Con questo particolare, occorre ordinare anche:
 • In addition to this part, you have to order the following:
 • Avec cette pièce, il est nécessaire de commander les pièces suivantes:

- Mit dieser Teil, du brauchst bestellen diese Teile:
 • Con esta pieza, es necesario pedir las siguientes piezas:

N° 800097884 - Qt. 1 / N° 8B0066778 - Qt. 1 / N° 800097885 - Qt. 2 / N° 8A0090944 - Qt. 1.



IMPIANTO DI RAFFREDDAMENTO
COOLING SYSTEM • CIRCUIT DE REFRIGERISSEMENT
KÜHLSYSTEM • INSTALACIÓN DE REFRIGERACIÓN

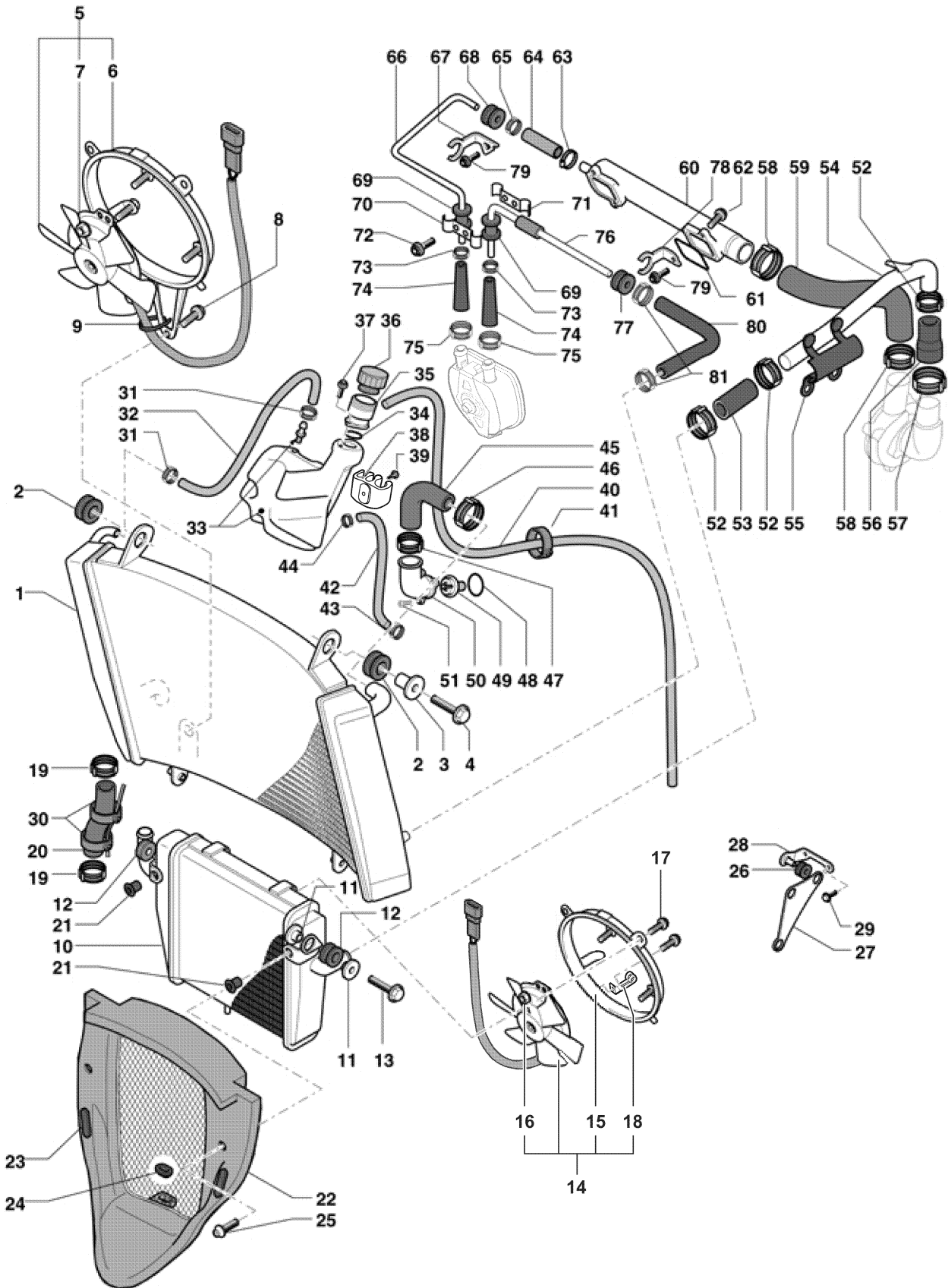

IMPIANTO DI RAFFREDDAMENTO
 COOLING SYSTEM • CIRCUIT DE REFROIDISSEMENT
 KÜHLSYSTEM • INSTALACIÓN DE REFRIGERACIÓN



N.	Code	Q.ty	Note	750 S	750 S 1+1	SPR	SR-SR1+1	SENNÀ	► I FRAME I ◄	► I ENGINE I ◄
39	8B0066778	1				•	•			
39	800035408	2						•		
40	8M0066179	1		•	•	•	•	•		
41	800092248	1		•	•	•	•	•		
42	800094186	1		•	•	•	•	•		
43	8E0092249	1		•	•	•	•	•		
44	8Q0092249	1		•	•	•	•	•		
45	800094184	1		•	•	•	•	•		
46	8G0092249	1		•	•	•	•	•		
47	8C0092249	1		•	•	•	•	•		
48	800069413	1		•	•	•	•	•		
49	800081283	1		•	•	•	•	•		
50	800087761	1		•	•	•	•	•		
51	800062728	3		•	•	•	•	•		
52	8G0092249	3		•	•	•	•	•		
53	8A0097109	1		•	•	•	•	•		
54	800094185	1		•	•	•	•	•		
55	800090417	1		•	•	•	•	•		
56	800090244	1		•	•	•	•	•		
57	8U0092249	1		•	•	•	•	•		
58	8F0092249	2		•	•	•	•	•		
59	800081280	1		•	•	•	•	•		
60	800081269	1		•	•	•	•	•		
61	800017679	2		•	•	•	•	•		
62	800062728	4		•	•	•	•	•		
63	8A0091025	1		•	•	•	•	•		
64	800089789	1		•	•	•	•	•		
65	8M0092249	1		•	•	•	•	•		
66	800089791	1		•	•	•	•	•		
67	800095504	1		•	•	•	•	•		
68	800089293	1		•	•	•	•	•		
69	800062724	2		•	•	•	•	•		
70	800089792	1		•	•	•	•	•		
71	800092669	1		•	•	•	•	•		
72	8E0067997	2		•	•	•	•	•		
73	8L0092249	2		•	•	•	•	•		
74	800092246	2		•	•	•	•	•		
75	8B0092249	2		•	•	•	•	•		
76	800095502	1		•	•	•	•	•		
77	800089293	1		•	•	•	•	•		
78	800095503	1		•	•	•	•	•		
79	8H0067545	2		•	•	•	•	•		
80	800097110	1		•	•	•	•	•		
81	8M0092249	2		•	•	•	•	•		





ASSIEME FRIZIONE
CLUTCH ASSEMBLY • ENSEMBLE EMBRAYAGE
BAUGRUPPE KUPPLUNG • CONJUNTO EMBRAGUE

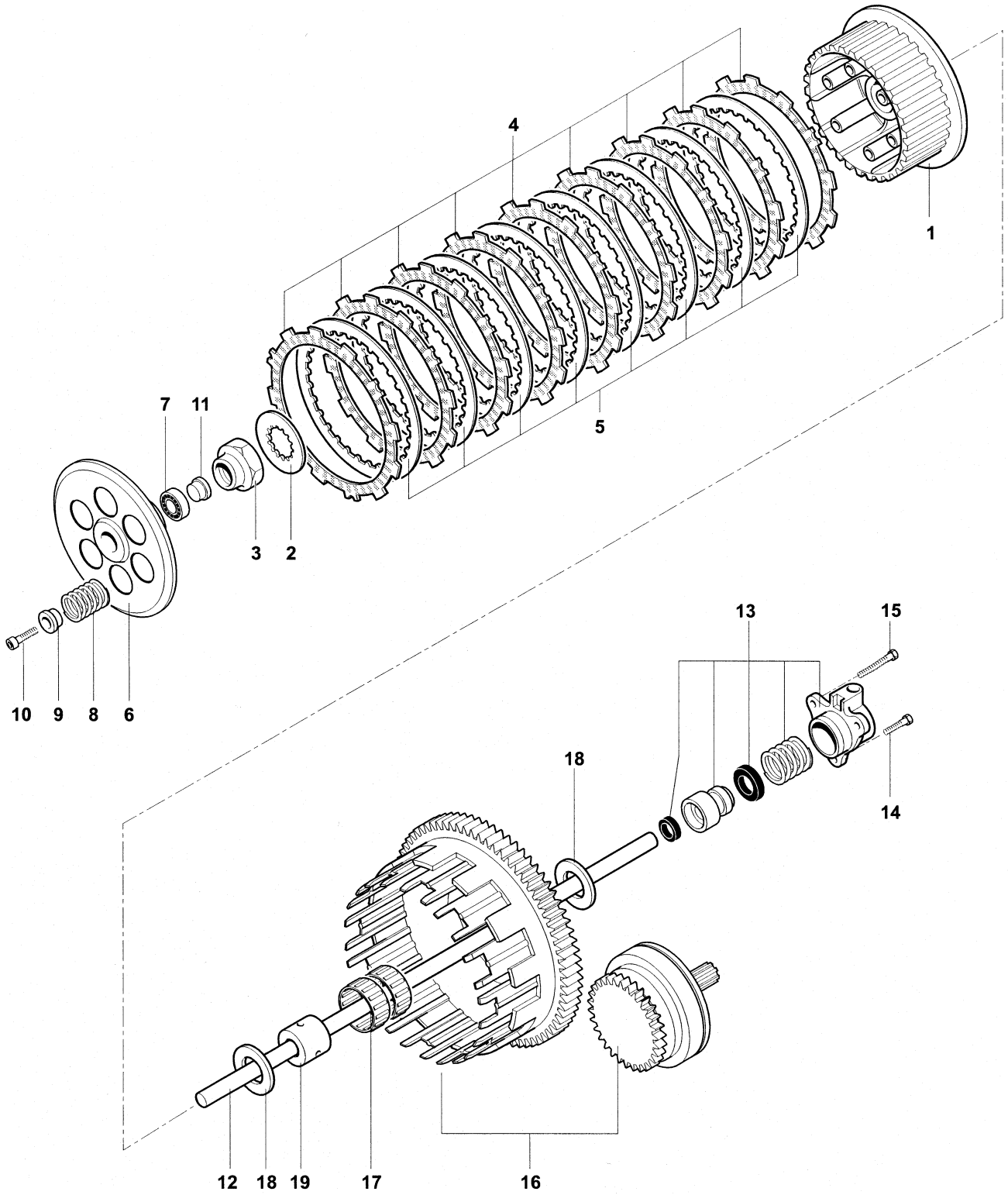

ASSIEME FRIZIONE

 CLUTCH ASSEMBLY • ENSEMBLE EMBRAYAGE
 BAUGRUPPE KUPPLUNG • CONJUNTO EMBRAGUE

N.	Code	Q.ty	Note	750 S	750 S 1+1	SPR	SR-SR1+1	SENNA	► I FRAME I ►	► I ENGINE I ►
1	800091926	1		•	•	•	•	•		
2	800081451	1		•	•	•	•	•		
3	800091924	1		•	•	•	•	•		
4	800081511	9		•	•					
4	800099521	9				•	•	•		
5	800081510	8		•	•	•	•	•		
6	800081508	1		•	•	•	•	•		
7	800034317	1		•	•	•	•	•		
8	800081516	6		•	•	•	•	•		
9	800081519	6		•	•	•	•	•		
10	60N102513	6		•	•	•	•	•		
11	800081402	1		•	•	•	•	•		
12	800088342	1		•	•	•	•	•		
13	800081478	1	EV 02	•	•					
13	80A081478	1	EV 03 / Euro 2	•	•					
13	80A081478	1				•	•			
13	800081478	1						•		
14	800062728	2		•	•	•	•	•		
15	800067545	1		•	•	•	•	•		
16	800096426	1		•	•	•	•	•		
17	800088418	1		•	•	•	•	•		
18	800081517	2		•	•	•	•	•		
19	800087313	1		•	•	•	•	•		



ASSIEME CAMBIO (F4 S / S 1+1 EV 02 / EV 03)

CHANGE GEAR ASSEMBLY (F4 S / S 1+1 EV 02 / EV 03) • ENSEMBLE BOÎTE DE VITESSE (F4 S / S 1+1 EV 02 / EV 03)
BAUGRUPPE GETRIEBE (F4 S / S 1+1 EV 02 / EV 03) • CONJUNTO CAMBIO (F4 S / S 1+1 EV 02 / EV 03)

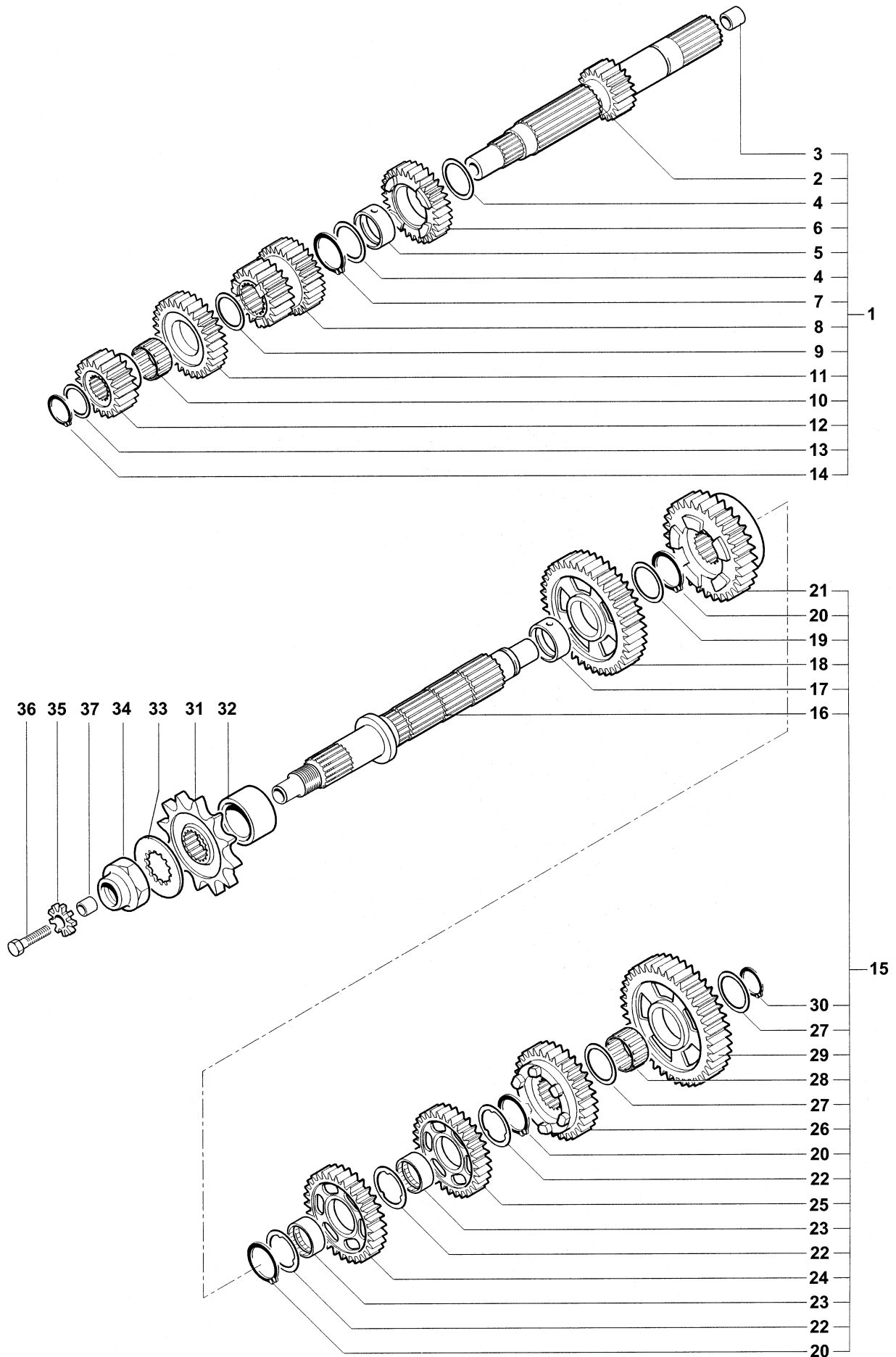

ASSIEME CAMBIO (F4 S / S 1+1 EV 02 / EV 03)

CHANGE GEAR ASSEMBLY (F4 S / S 1+1 EV 02 / EV 03) • ENSEMBLE BOÎTE DE VITESSE (F4 S / S 1+1 EV 02 / EV 03)
 BAUGRUPPE GETRIEBE (F4 S / S 1+1 EV 02 / EV 03) • CONJUNTO CAMBIO (F4 S / S 1+1 EV 02 / EV 03)



N.	Code	Q.ty	Note	750 S	750 S 1+1	SPR	SR-SR1+1	SENNÀ	► I FRAME I ►	► I ENGINE I ►
1	800098882	1		•	•					► I 06539 06844 I ► ► I 07235
2	800091927	1		•	•					► I 06539 06844 I ► ► I 07235
3	800086699	1		•	•					► I 06539 06844 I ► ► I 07235
4	8C0030362	2		•	•					► I 06539 06844 I ► ► I 07235
5	800081566	1		•	•					► I 06539 06844 I ► ► I 07235
6	800081565	1		•	•					► I 06539 06844 I ► ► I 07235
7	800088415	1		•	•					► I 06539 06844 I ► ► I 07235
8	800091891	1		•	•					► I 06539 06844 I ► ► I 07235
9	8D0081569	1		•	•					► I 06539 06844 I ► ► I 07235
10	8A0025044	1		•	•					► I 06539 06844 I ► ► I 07235
11	800088416	1		•	•					► I 06539 06844 I ► ► I 07235
12	800091893	1		•	•					► I 06539 06844 I ► ► I 07235
13	8G0048590	1		•	•					► I 06539 06844 I ► ► I 07235
14	66N221207	1		•	•					► I 06539 06844 I ► ► I 07235
15	800098883	1		•	•					► I 06539 06844 I ► ► I 07235
16	800093990	1		•	•					► I 06539 06844 I ► ► I 07235
17	800081566	1		•	•					► I 06539 06844 I ► ► I 07235
18	800081573	1		•	•					► I 06539 06844 I ► ► I 07235
19	8C0030362	2		•	•					► I 06539 06844 I ► ► I 07235





ASSIEME CAMBIO (F4 S / S 1+1 EV 02 / EV 03)

CHANGE GEAR ASSEMBLY (F4 S / S 1+1 EV 02 / EV 03) • ENSEMBLE BOÎTE DE VITESSE (F4 S / S 1+1 EV 02 / EV 03)
 BAUGRUPPE GETRIEBE (F4 S / S 1+1 EV 02 / EV 03) • CONJUNTO CAMBIO (F4 S / S 1+1 EV 02 / EV 03)

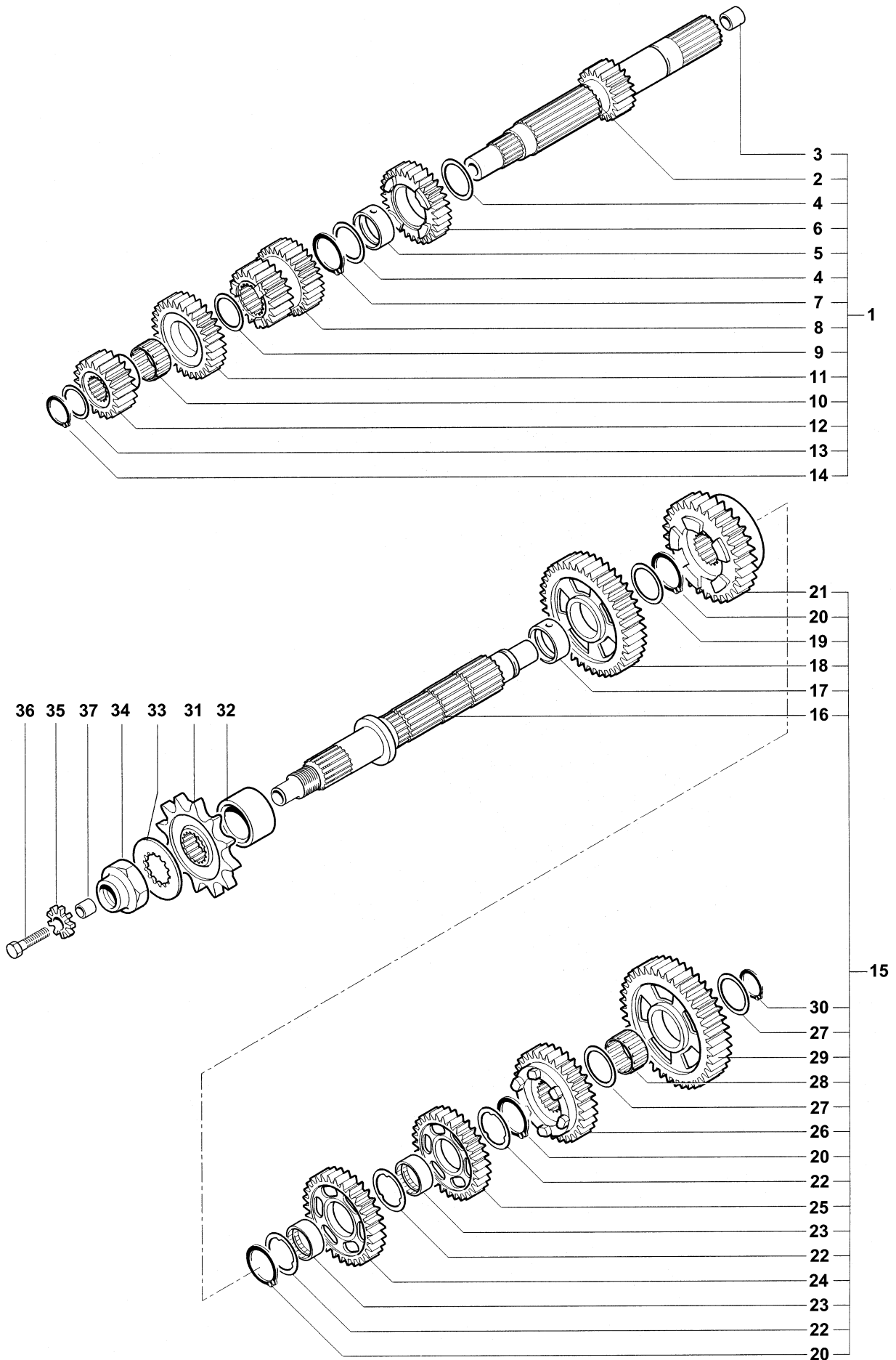

ASSIEME CAMBIO (F4 S / S 1+1 EV 02 / EV 03)

CHANGE GEAR ASSEMBLY (F4 S / S 1+1 EV 02 / EV 03) • ENSEMBLE BOÎTE DE VITESSE (F4 S / S 1+1 EV 02 / EV 03)
 BAUGRUPPE GETRIEBE (F4 S / S 1+1 EV 02 / EV 03) • CONJUNTO CAMBIO (F4 S / S 1+1 EV 02 / EV 03)



N.	Code	Q.ty	Note	750 S	750 S 1+1	SPR	SR-SR1+1	SENNÀ	► I FRAME I ►	► I ENGINE I ►
20	66N221213	3		•	•					► I 06539 06844 I ► ► I 07235
21	800088417	1		•	•					► I 06539 06844 I ► ► I 07235
22	800081578	3		•	•					► I 06539 06844 I ► ► I 07235
23	800081577	2		•	•					► I 06539 06844 I ► ► I 07235
24	800081575	1		•	•					► I 06539 06844 I ► ► I 07235
25	800081576	1		•	•					► I 06539 06844 I ► ► I 07235
26	800081579	1		•	•					► I 06539 06844 I ► ► I 07235
27	8D0018296	2		•	•					► I 06539 06844 I ► ► I 07235
28	800035006	1		•	•					► I 06539 06844 I ► ► I 07235
29	800081580	1		•	•					► I 06539 06844 I ► ► I 07235
30	66N221209	1		•	•					► I 06539 06844 I ► ► I 07235
31	800098034	1		•	•					► I 06539 06844 I ► ► I 07235
32	8A0081466	1		•	•					► I 06539 06844 I ► ► I 07235
33	800081451	1		•	•					► I 06539 06844 I ► ► I 07235
34	800091924	1		•	•					► I 06539 06844 I ► ► I 07235
35	800099064	1		•	•					► I 06539 06844 I ► ► I 07235
36	800062728	1		•	•					► I 06539 06844 I ► ► I 07235
37	800051549	1		•	•					► I 06539 06844 I ► ► I 07235





SELETTORE CAMBIO
GEAR SELECTOR • SÉLECTEUR DE VITESSES
GANGSCHALTER • SELECTOR CAMBIO

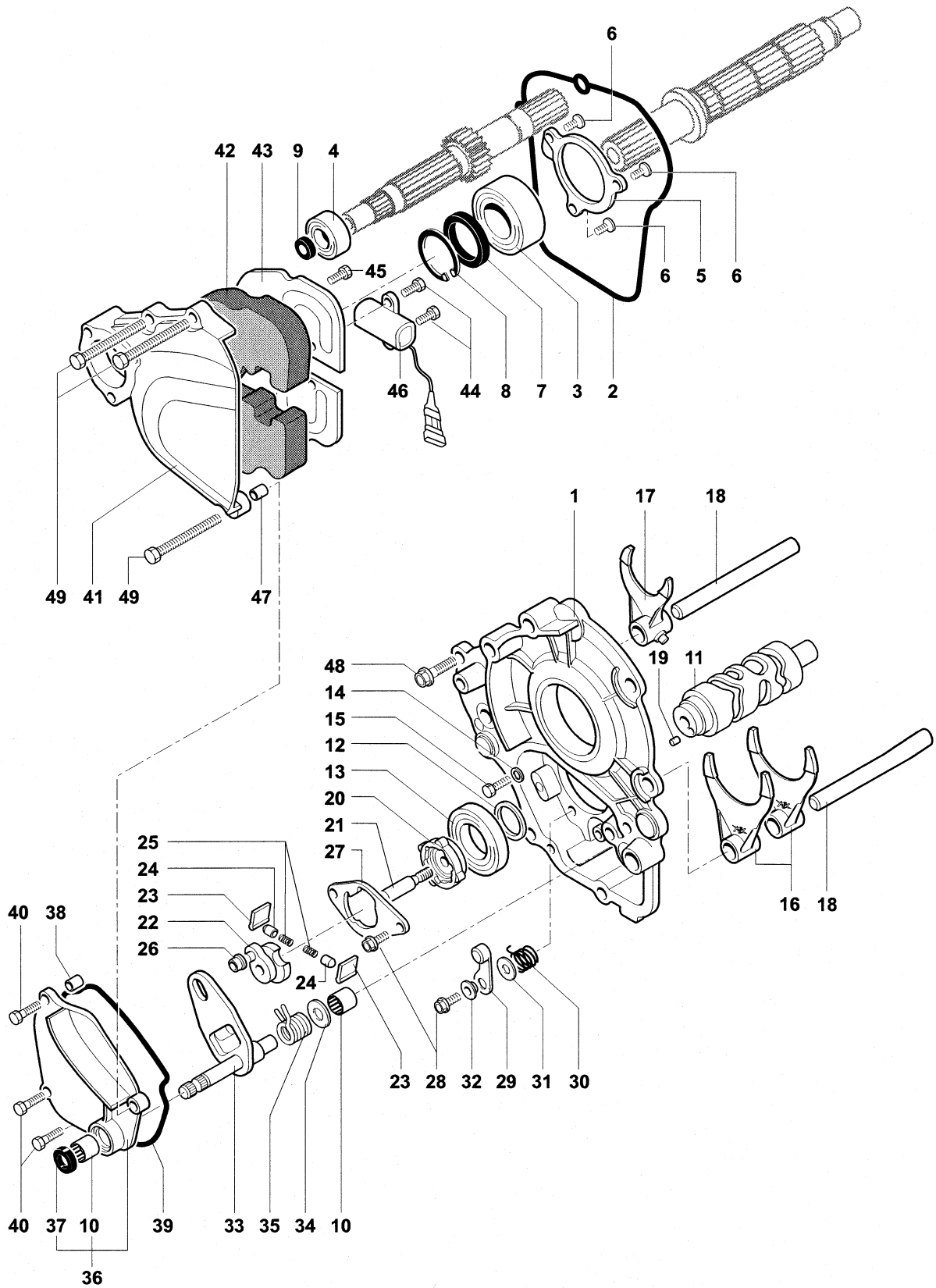

SELETTORE CAMBIO

 GEAR SELECTOR • SÉLECTEUR DE VITESSES
 GANGSCHALTER • SELECTOR CAMBIO

N.	Code	Q.ty	Note	750 S	750 S 1+1	SPR	SR-SR1+1	SENNÀ	► I FRAME I ►	► I ENGINE I ►
1	800092488	1		•	•	•	•	•		
2	800086117	1		•	•	•	•	•		
3	8000A3754	1	EV 02 / EV 03	•	•					
3	8000A2318	1	Euro 2	•	•					
3	8000A3754	1				•	•	•		
4	800086116	1	EV 02 / EV 03	•	•					
4	8000A1086	1	Euro 2	•	•					
4	800086116	1				•	•	•		
5	800086114	1		•	•	•	•	•		
6	800028327	3		•	•	•	•	•		
7	800089410	1		•	•	•	•	•		
8	800091603	1		•	•	•	•	•		
9	800064296	1		•	•	•	•	•		
10	800051191	2		•	•	•	•	•		
11	8A0089416	1		•	•	•	•	•		
12	8A0036022	1	≠ 0.2	•	•	•	•	•		
12	8B0036022	1	≠ 0.3	•	•	•	•	•		
12	8C0036022	1	≠ 0.4	•	•	•	•	•		
13	8A0021774	1		•	•	•	•	•		
14	8000A0901	2		•	•	•	•	•		
15	800062726	2		•	•	•	•	•		
16	800081583	2		•	•	•	•	•		
17	800081584	1		•	•					► I 06539 06844 I ► ► I 07235 06540 I ► ► I 06742 07236 I ►
17	8A0081584	1		•	•					
17	800081584	1				•	•	•		
18	800081585	2		•	•	•	•	•		
19	800038520	1		•	•	•	•	•		
20	8A0097739	1		•	•	•	•	•		
21	800098149	1		•	•	•	•	•		
22	800087299	1		•	•	•	•	•		
23	800071007	2		•	•	•	•	•		
24	800071008	2		•	•	•	•	•		
25	800071009	2		•	•	•	•	•		
26	800071010	1		•	•	•	•	•		
27	800081590	1		•	•	•	•	•		
28	800062726	3		•	•	•	•	•		
29	800085495	1		•	•	•	•	•		
30	800092490	1		•	•	•	•	•		
31	800086107	1		•	•	•	•	•		
32	800085493	1		•	•	•	•	•		
33	800089424	1		•	•	•	•	•		
34	8G0004551	1		•	•	•	•	•		
35	800072826	1		•	•	•	•	•		
36	800092491	1		•	•	•	•	•		
37	8A0028855	1		•	•	•	•	•		
38	800051549	1		•	•	•	•	•		
39	800089406	1		•	•	•	•	•		
40	800062729	3		•	•	•	•	•		
41	800092494	1	EV 02	•	•					
41	80A092494	1	EV 03 / Euro 2	•	•					
41	80A092494	1				•	•			
41	800092494	1						•		
42	800088347	1		•	•	•	•	•		
43	800088344	1		•	•	•	•	•		
44	800067997	2		•	•	•	•	•		
45	8D0067997	1		•	•	•	•	•		
46	800088346	1		•	•	•	•	•		
47	800086131	2		•	•	•	•	•		
48	800091697	6		•	•	•	•	•		
49	8B0091697	3		•	•	•	•	•		



GRUPPO POMPA BENZINA

FUEL PUMP ASSEMBLY • GROUPE POMPE D'ALIMENTATION
BAUGRUPPE BENZINPUMPE • GRUPO BOMBA GASOLINA

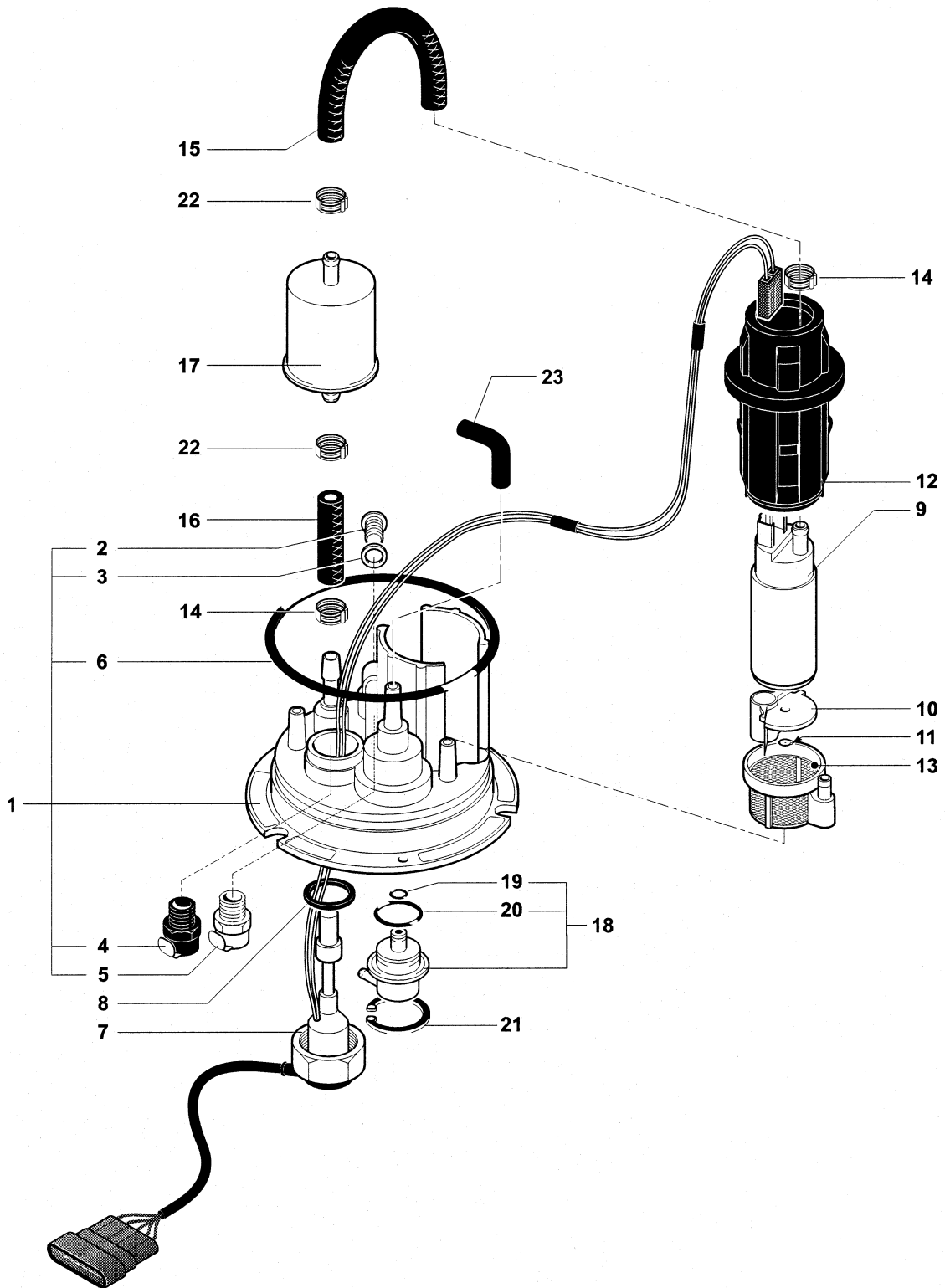

GRUPPO POMPA BENZINA

FUEL PUMP ASSEMBLY • GROUPE POMPE D'ALIMENTATION
 BAUGRUPPE BENZINPUMPE • GRUPO BOMBA GASOLINA



N.	Code	Q.ty	Note	750 S	750 S 1+1	SPR	SR-SR1+1	SENNA	► I FRAME I ◄	► I ENGINE I ◄
1	800094275	1		•	•	•	•	•		
2	800090927	1		•	•	•	•	•		
3	800021480	1		•	•	•	•	•		
4	80A090925	1		•	•	•	•	•		
5	800090925	1		•	•	•	•	•		
6	800090939	1		•	•	•	•	•		
7	8000A1400	1		•	•	•	•	•		
8	800090919	1		•	•	•	•	•		
9	800090920	1		•	•	•	•	•		
10	800093410	1		•	•	•	•	•		
11	800093411	1		•	•	•	•	•		
12	800090921	1		•	•	•	•	•		
13	800098305	1		•	•	•	•	•		
14	8M0092249	2		•	•	•	•	•		
15	8E0087431	1		•	•	•	•	•		
16	8H0087431	1		•	•	•	•	•		
17	800088585	1		•	•	•	•	•		
18	800090929	1		•	•	•	•	•		
19	800093323	1		•	•	•	•	•		
20	800093324	1		•	•	•	•	•		
21	800090930	1		•	•	•	•	•		
22	8S0092249	2		•	•	•	•	•		
23	800098304	1		•	•	•	•	•		



ALIMENTAZIONE MOTORE
FUEL SYSTEM • ALIMENTATION MOTEUR
MOTORVERSORGUNG • ALIMENTACIÓN MOTOR

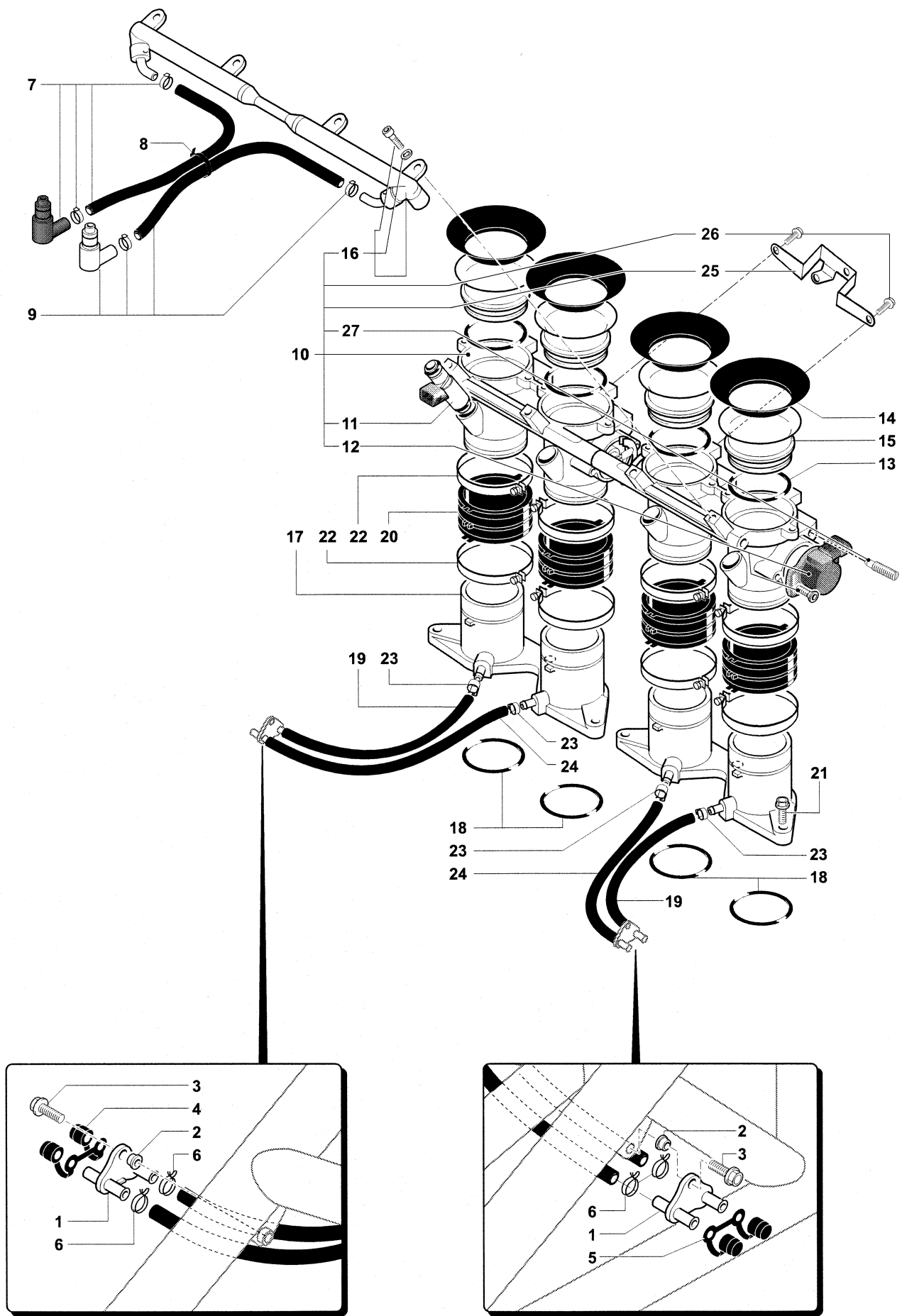



N.	Code	Q.ty	Note	750 S	750 S 1+1	SPR	SR-SR1+1	SENNÀ	► I FRAME I ►	► I ENGINE I ►
1	800089801	2		•	•	•	•	•		
2	800067412	2		•	•	•	•	•		
3	8E0067997	2		•	•	•	•	•		
4	800089799	1	❶	•	•	•	•	•		
5	800089800	1	❶	•	•	•	•	•		
6	8A0091634	4		•	•	•	•	•		
7	80A0A1558	1		•	•	•	•	•		
8	800056444	1		•	•	•	•	•		
9	8000A1558	1		•	•	•	•	•		
10	8000A4827	1		•	•	•	•	•		
11	8000A1440	4		•	•	•	•	•		
12	8000A1450	1		•	•	•	•	•		
13	800081304	4		•	•	•	•	•		
14	800090350	4		•	•	•	•	•		
15	800097917	4		•	•			•		
15	8000A1355	4				•	•			
16	8000A1442	1		•	•	•	•	•		
17	800092449	2		•	•	•	•	•		
18	800019965	4		•	•	•	•	•		
19	800091037	2		•	•	•	•	•		
20	800089403	4		•	•	•	•	•		
21	8PA067545	6		•	•	•	•	•		
22	800089404	8		•	•	•	•	•		
23	800096458	4		•	•	•	•	•		
24	8A0091037	2		•	•	•	•	•		
25	8000A1453	1		•	•	•	•	•		
26	8E0067997	2		•	•	•	•	•		
27	8000A1455	2		•	•	•	•	•		

❶ Esclusi gli USA (vedi tavola K02) - USA excluded (see table K02) - Sauf les USA (voir planche K02) - Ausschließlich USA (siehe Tafel K02) - Excluidos los USA (ver tabla K02).



AVVIAMENTO

STARTING SYSTEM • DÉMARREUR

ANLASSERSYSTEM • PUESTA EN MARCHA

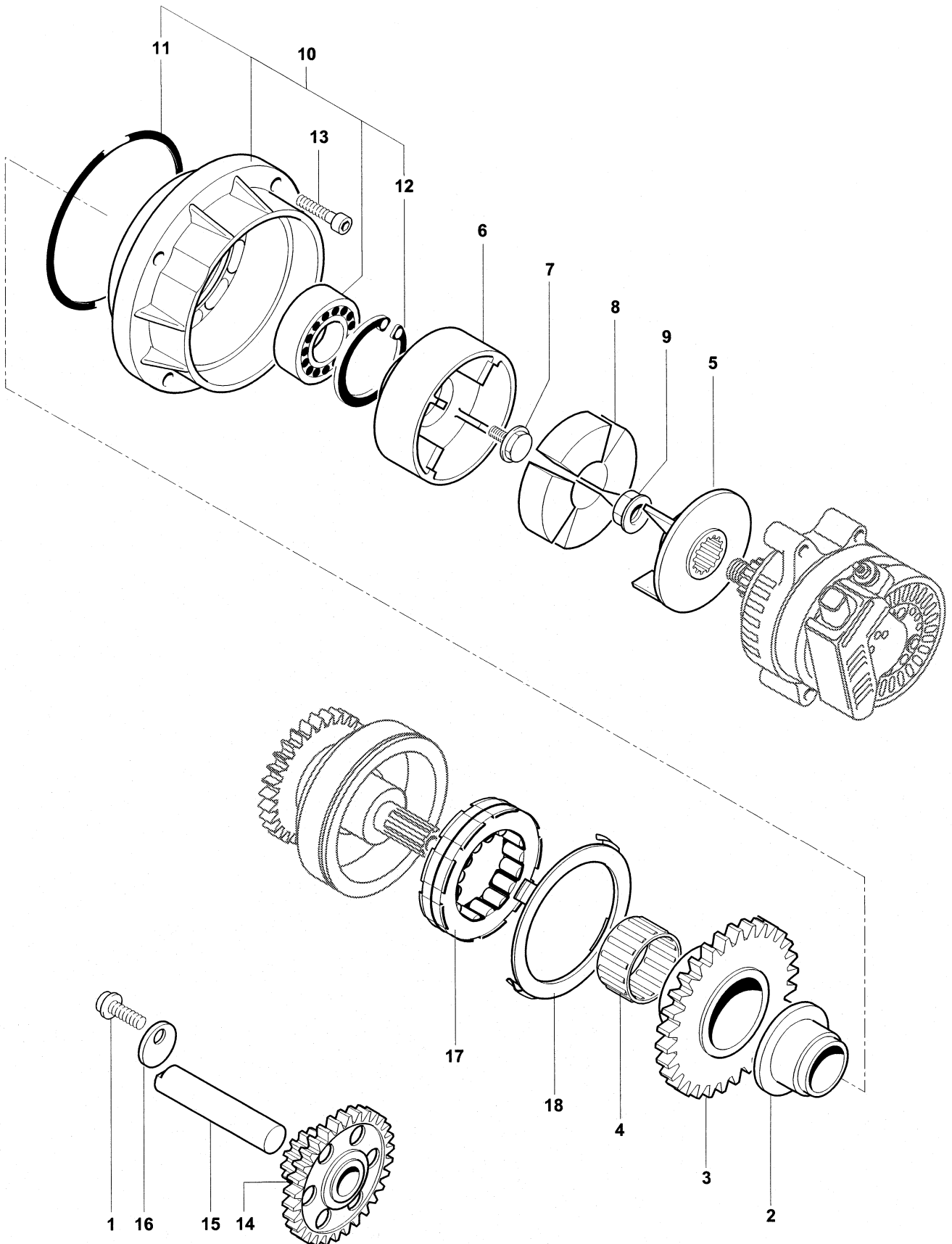

AVVIAMENTO

STARTING SYSTEM • DÉMARREUR
ANLASSERSYSTEM • PUESTA EN MARCHA



N.	Code	Q.ty	Note	750 S	750 S 1+1	SPR	SR-SR1+1	SENNÀ	► I FRAME I ►	► I ENGINE I ►
1	800062726	1		•	•	•	•	•		
2	800086208	1		•	•	•	•	•		
3	800087288	1		•	•	•	•	•		
4	800048551	1		•	•	•	•	•		
5	800081445	1		•	•	•	•	•		
6	800087290	1		•	•	•	•	•		
7	800081393	1		•	•	•	•	•		
8	8000A3812	4		•	•	•	•	•		
9	800038624	1		•	•	•	•	•		
10	800081461	1		•	•	•	•	•		
11	800081453	1		•	•	•	•	•		
12	66N021272	1		•	•	•	•	•		
13	60N102509	4		•	•	•	•	•		
14	800091886	1		•	•	•	•	•		
15	800081380	1		•	•	•	•	•		
16	800081381	1		•	•	•	•	•		
17	800087289	1		•	•	•	•	•		
18	800086732	1		•	•	•	•	•		



IMPIANTO ELETTRICO MOTORE

ENGINE ELECTRIC SYSTEM • INSTALLATION ÉLECTRIQUE MOTEUR
ELEKTRISCHE ANLAGE MOTOR • INSTALACIÓN ELÉCTRICA MOTOR

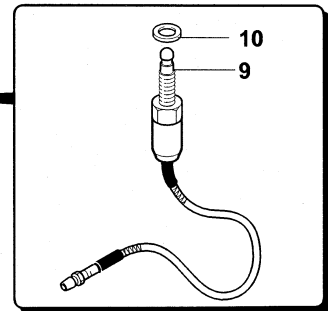
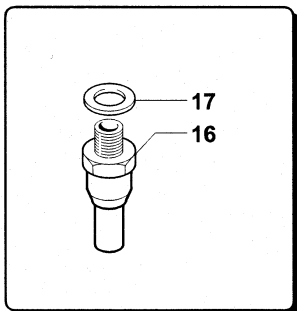
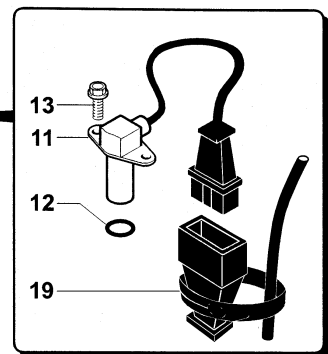
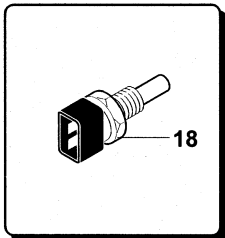
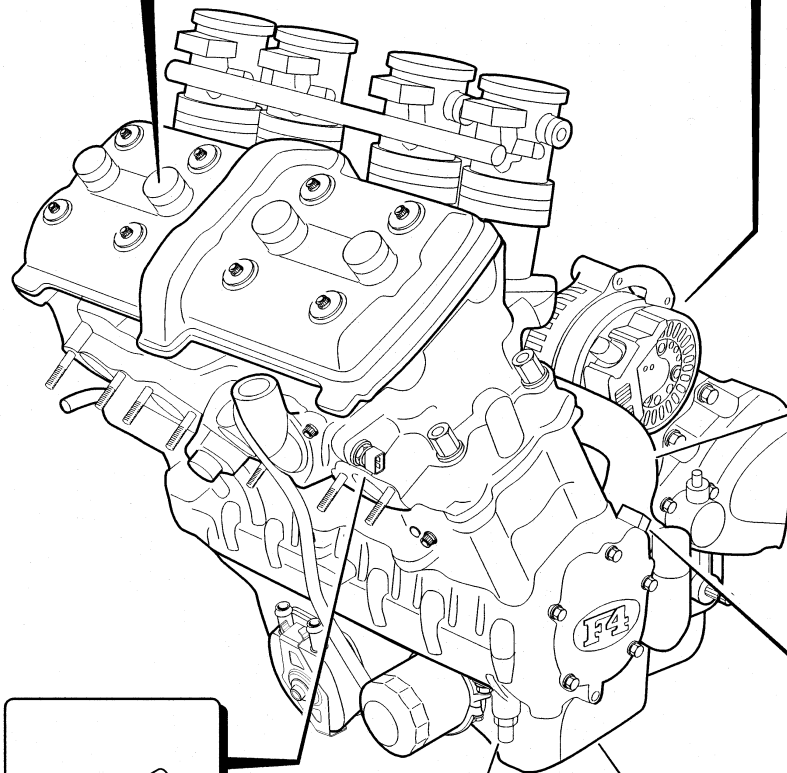
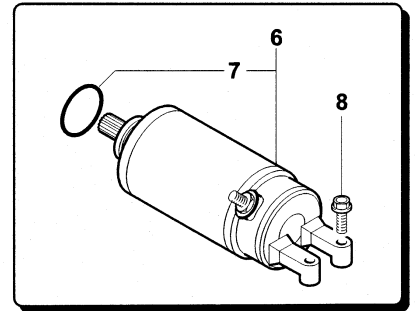
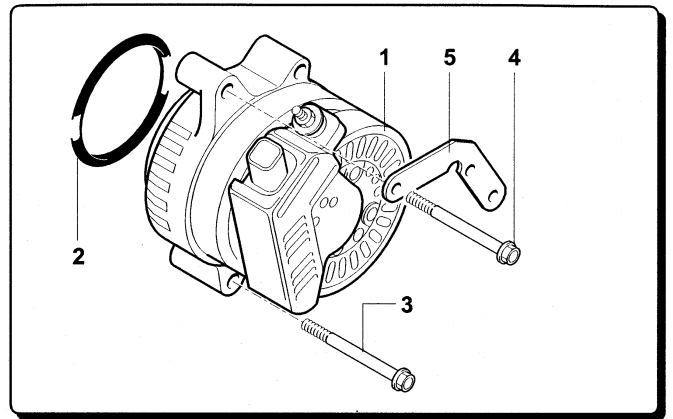
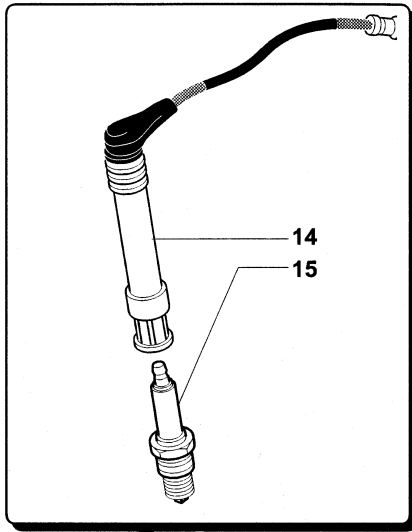

IMPIANTO ELETTRICO MOTORE

 ENGINE ELECTRIC SYSTEM • INSTALLATION ÉLECTRIQUE MOTEUR
 ELEKTRISCHE ANLAGE MOTOR • INSTALACIÓN ELÉCTRICA MOTOR

N.	Code	Q.ty	Note	750 S	750 S 1+1	SPR	SR-SR1+1	SENNA	► I FRAME I ►	► I ENGINE I ►
1	8A0081387	1		•	•	•	•	•		
2	800086223	1		•	•	•	•	•		
3	8C0091697	1		•	•	•	•	•		
4	8B0098219	2		•	•	•	•	•		
5	800097278	1		•	•	•	•	•		
6	800081388	1		•	•	•	•	•		
7	800091597	1		•	•	•	•	•		
8	800062729	2		•	•	•	•	•		
9	800087124	1		•	•	•	•	•		
10	800039335	1		•	•	•	•	•		
11	800090184	1		•	•	•	•	•		
12	800022551	1		•	•	•	•	•		
13	800067997	2		•	•	•	•	•		
14	800081221	2	①	•	•	•	•	•		
14	8A0081221	2	②	•	•	•	•	•		
15	800095906	4	NGK CR9EB	•	•					
15	8000A0696	4	CHAMPION G 54 V			•	•	•		
15	800099561	4	NGK CR9EKB					•		
15	800098527	4	NGK R 0045 - J 10					•		
16	800089972	1		•	•	•	•	•		
17	62N015676	1		•	•	•	•	•		
18	800088575	1		•	•	•	•	•		
19	800092248	1		•	•	•	•	•		

- ① Guaina rossa (bancata 1-4) - Red sheath (porks 1-4) - Joint rouge (rampe 1-4) - Rote Dichtung (Zylinder 1-4) - Funda rojo (horquillas 1-4)
- ② Guaina gialla (bancata 2-3) - Yellow sheath (porks 2-3) - Joint jaune (rampe 2-3) - Gelbe Dichtung (Zylinder 2-3) - Funda amarillo (horquillas 2-3)



IMPIANTO DI SCARICO
EXHAUST SYSTEM • ÉCHAPPEMENT
ABGASANLAGE • INSTALACIÓN DE ESCAPE

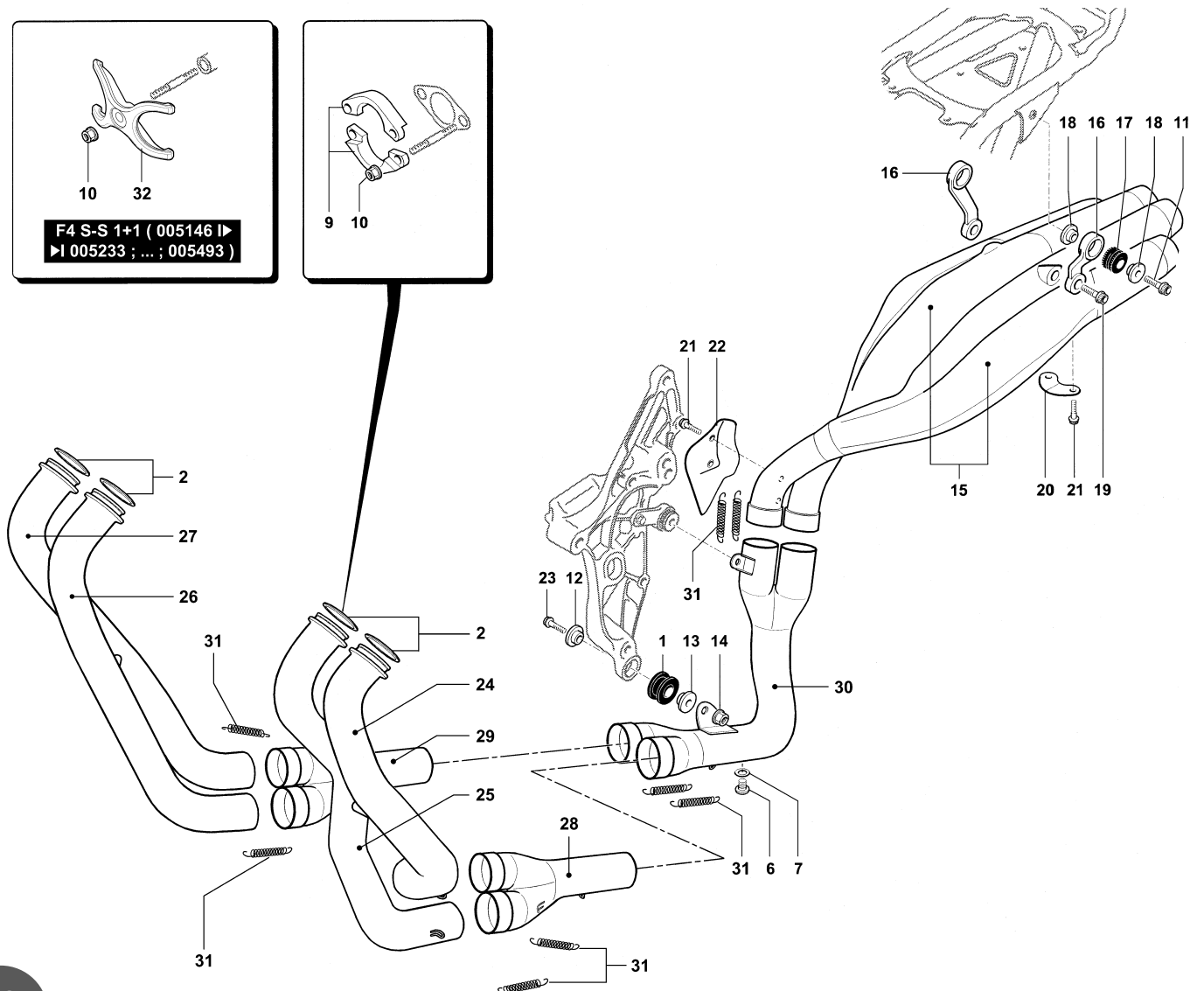
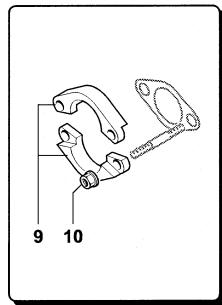
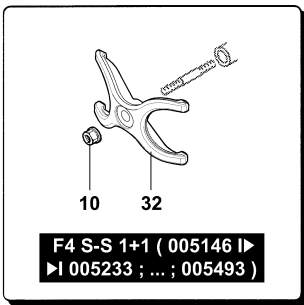
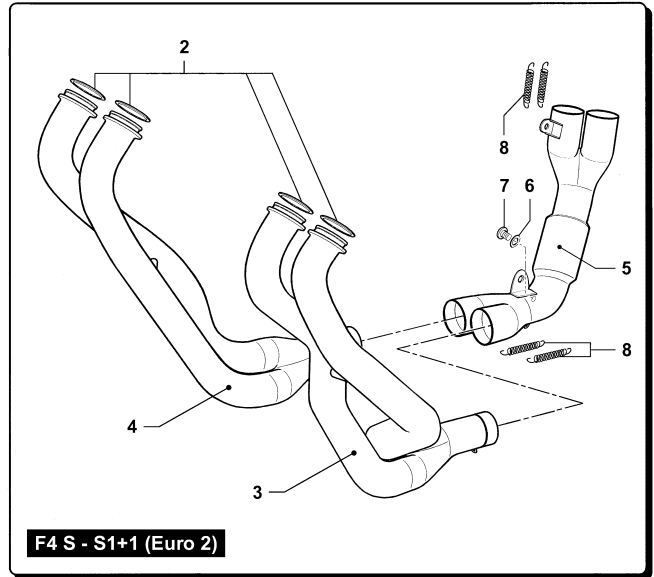
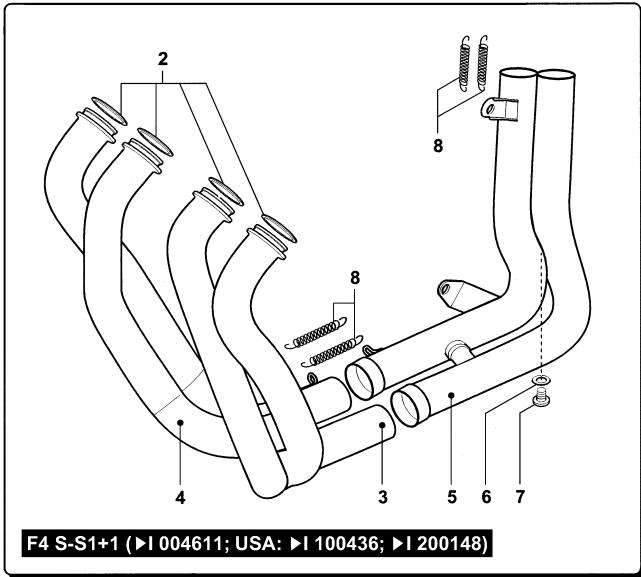

IMPIANTO DI SCARICO
 EXHAUST SYSTEM • ÉCHAPPEMENT
 ABGASANLAGE • INSTALACIÓN DE ESCAPE



N.	Code	Q.ty	Note	750 S	750 S 1+1	SPR	SR-SR1+1	SENNÀ	► I FRAME I ►	► I ENGINE I ►
1	800089302	1		•	•	•	•	•		
2	800081263	4		•	•				► I 004611	
2	800099383	4		•	•				004718 I ►	
2	800081263	4	USA	•					► I 100436	
2	800099383	4	USA	•					100437 I ►	
2	800081263	4	USA		•				► I 200149	
2	800099383	4	USA		•				200150 I ►	
2	800099383	4				•	•	•		
3	8A0090360	1		•	•				► I 004611	
3	8A00A3048	1	1 Euro 2	•	•					
3	8A0090360	1	USA	•					► I 100436	
3	8A0090360	1	USA		•				► I 200149	
4	8A0090361	1		•	•				► I 004611	
4	8A00A3049	1	1 Euro 2	•	•					
4	8A0090361	1	USA	•					► I 100436	
4	8A0090361	1	USA		•				► I 200149	
5	8A0090362	1		•	•				► I 004611	
5	8A00A3050	1	1 Euro 2	•	•					
5	8A0090362	1	USA	•					► I 100436	
5	8A0090362	1	USA		•				► I 200149	
6	800021480	1		•	•	•	•	•		
7	800090972	1		•	•	•	•	•		
8	800092649	4		•	•				► I 004611	
8	8000A1239	4	1 Euro 2	•	•					
8	800092649	4	USA	•					► I 100436	
8	800092649	4	USA		•				► I 200149	
9	800081227	8		•	•	•	•	•	► I 005145 005234 I ► ► I 005237 005261 I ► ► I 005432 005470 I ► ► I 005492 005494 I ►	
10	80B043928	8		•	•				► I 004611	
10	8000A1238	8		•	•				004718 I ► ► I 005145 005234 I ► ► I 005237 005261 I ► ► I 005432 005470 I ► ► I 005492 005494 I ►	
10	80B043928	2		•	•				005146 I ► ► I 005233 005238 I ► ► I 005260 005433 I ► ► I 005469 005493	
10	80B043928	8	USA	•					► I 100436	
10	8000A1238	8	USA	•					100437 I ►	
10	80B043928	8	USA		•				► I 200149	
10	8000A1238	8	USA		•				200150 I ►	



1 Esclusi gli USA - USA excluded - Sauf les USA - Ausschließlich USA - Excluidos los USA.



IMPIANTO DI SCARICO
EXHAUST SYSTEM • ÉCHAPPEMENT
ABGASANLAGE • INSTALACIÓN DE ESCAPE

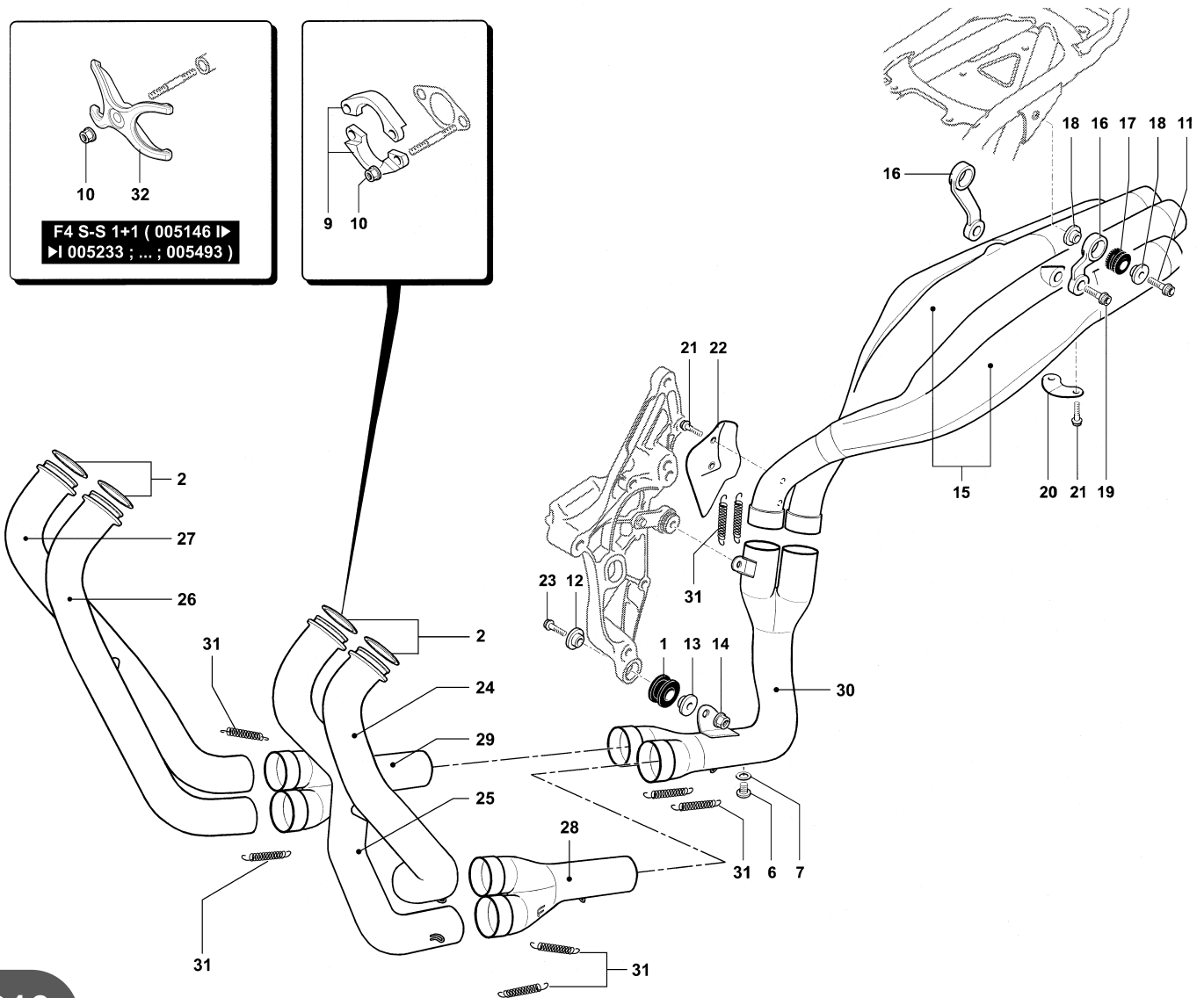
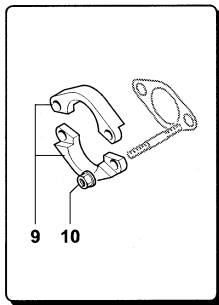
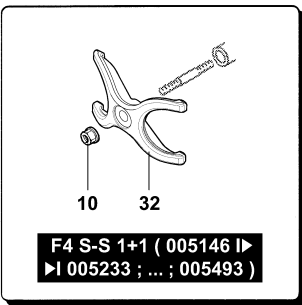
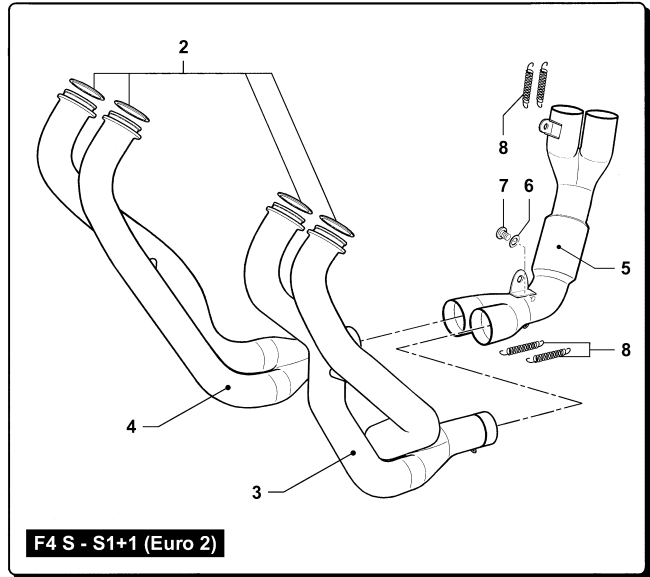
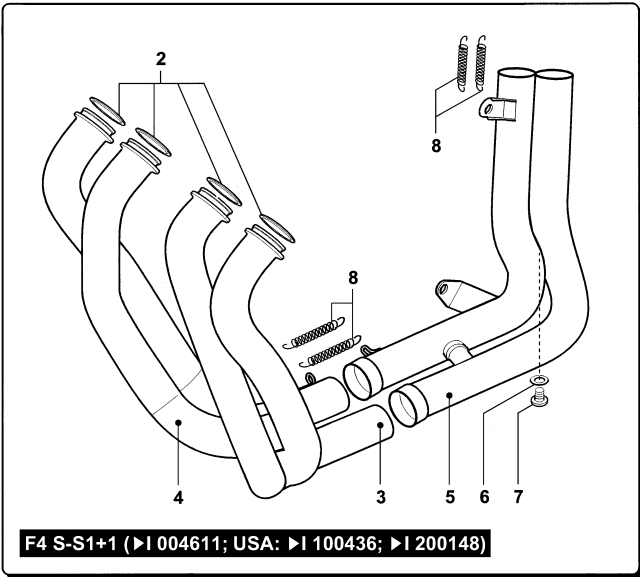

IMPIANTO DI SCARICO
 EXHAUST SYSTEM • ÉCHAPPEMENT
 ABGASANLAGE • INSTALACIÓN DE ESCAPE



N.	Code	Q.ty	Note	750 S	750 S 1+1	SPR	SR-SR1+1	SENNÀ	► I FRAME I ►	► I ENGINE I ►
10	8000A1238	8				•	•	•		
11	8L0090425	2		•	•	•	•	•		
12	800089299	1		•	•	•	•	•		
13	800090942	1		•	•	•	•	•		
14	800044240	1		•	•	•	•	•		
15	800095845	1		•	•	•				
15	80B095845	1					•			
15	80A095845	1						•		
16	800090378	2		•	•	•	•	•		
17	800062651	2		•	•	•	•	•		
18	800090943	4		•	•	•	•	•		
19	8G0090425	2		•	•	•	•	•		
20	800090974	1		•	•	•	•	•		
21	8B0090425	4		•	•	•	•	•		
22	800091680	1		•	•	•		•		
22	80A091680	1					•			
23	8M0090425	1		•	•	•	•	•		
24	8A0099422	1		•	•				004718 I ►	
24	8A0099422	1	USA	•					100437 I ►	
24	8A0099422	1	USA		•				200150 I ►	
24	800099422	1				•	•	•		
25	8A0099423	1		•	•				004718 I ►	
25	8A0099423	1	USA	•					100437 I ►	
25	8A0099423	1	USA		•				200150 I ►	
25	800099423	1				•	•	•		
26	8A0099424	1		•	•				004718 I ►	
26	8A0099424	1	USA	•					100437 I ►	
26	8A0099424	1	USA		•				200150 I ►	
26	800099424	1				•	•	•		
27	8A0099425	1		•	•				004718 I ►	
27	8A0099425	1	USA	•					100437 I ►	
27	8A0099425	1	USA		•				200150 I ►	
27	800099425	1				•	•	•		
28	8A0099394	1		•	•				004718 I ►	
28	8A0099394	1	USA	•					100437 I ►	
28	8A0099394	1	USA		•				200150 I ►	
28	800099394	1				•	•	•		
29	8A0099395	1		•	•				004718 I ►	
29	8A0099395	1	USA	•					100437 I ►	
29	8A0099395	1	USA		•				200150 I ►	
29	800099395	1				•	•	•		
30	8A0099396	1		•	•				004718 I ►	
30	8A0099396	1	USA	•					100437 I ►	
30	8A0099396	1	USA		•				200150 I ►	
30	800099396	1				•	•	•		
31	8000A1239	8		•	•				004718 I ►	
31	8000A1239	8	USA	•					100437 I ►	
31	8000A1239	8	USA		•				200150 I ►	
31	8000A1239	8				•	•	•		
32	800090419	2		•	•				005146 I ►	
									► I 005233	
									005238 I ►	
									► I 005260	
									005433 I ►	
									► I 005469	
									005493	





ASSIEME CAMBIO (F4 S / S 1+1 EV 03 - Euro 2 / SPR / SR / SENNA)

CHANGE GEAR ASSEMBLY (F4 S / S 1+1 EV 03 - Euro 2 / SPR / SR / SENNA) • ENSEMBLE BOÎTE DE VITESSE (F4 S / S 1+1 EV 03 - Euro 2 / SPR / SR / SENNA) • BAUGRUPPE GETRIEBE (F4 S / S 1+1 EV 03 - Euro 2 / SPR / SR / SENNA) • CONJUNTO CAMBIO (F4 S / S 1+1 EV 03 - Euro 2 / SPR / SR / SENNA)

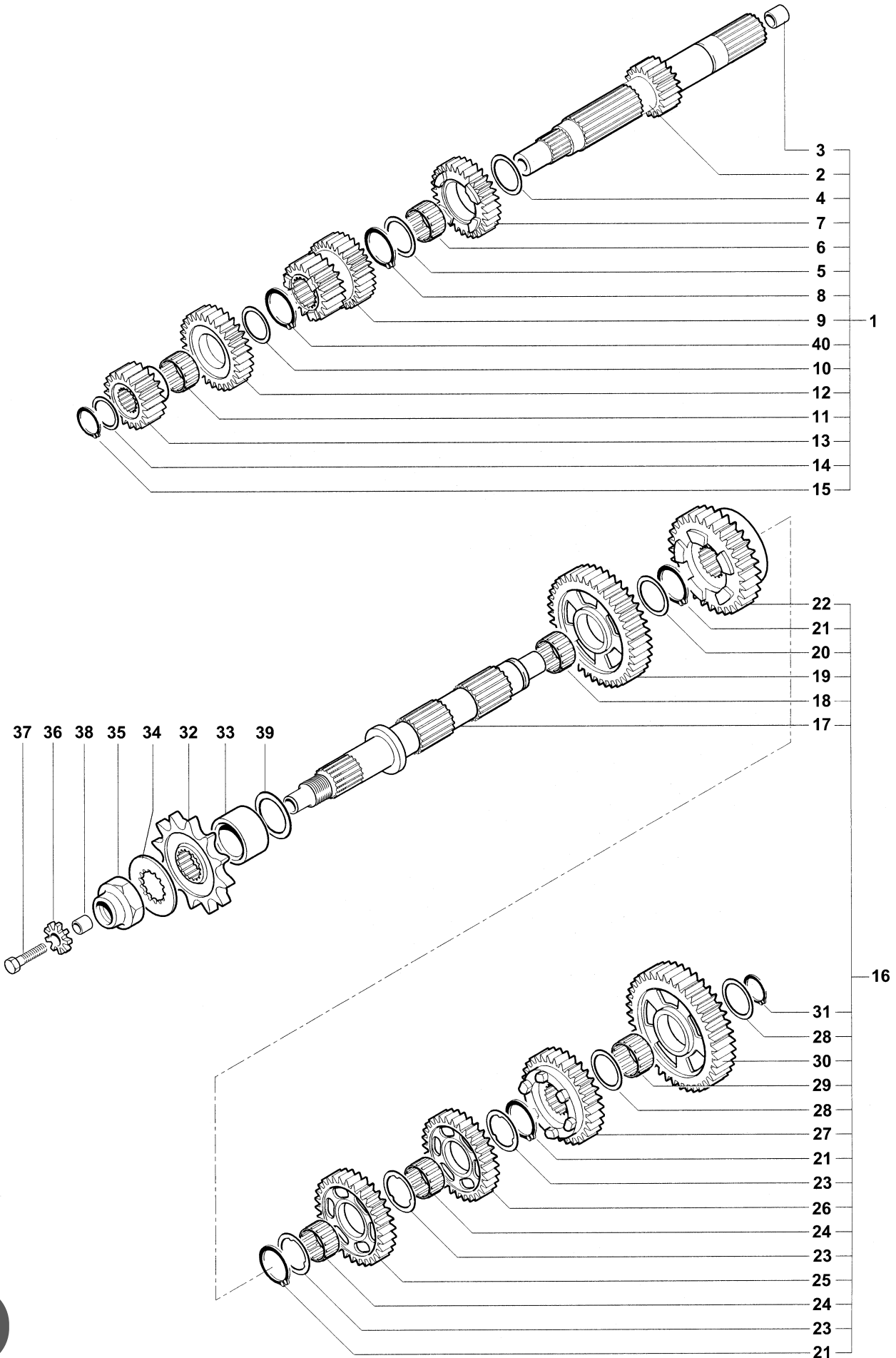

ASSIEME CAMBIO (F4 S / S 1+1 EV 03 - Euro 2 / SPR / SR / SENNA)

 CHANGE GEAR ASSEMBLY (F4 S / S 1+1 EV 03 - Euro 2 / SPR / SR / SENNA) • ENSEMBLE BOÎTE DE VITESSE
 (F4 S / S 1+1 EV 03 - Euro 2 / SPR / SR / SENNA) • BAUGRUPPE GETRIEBE (F4 S / S 1+1 EV 03 - Euro 2 / SPR /
 SR / SENNA) • CONJUNTO CAMBIO (F4 S / S 1+1 EV 03 - Euro 2 / SPR / SR / SENNA)



N.	Code	Q.ty	Note	750 S	750 S 1+1	SPR	SR-SR1+1	SENNA	► I FRAME I ►	► I ENGINE I ►
1	8000A2628	1		•	•					06540 I ► ► I 06742 07236 I ►
1	8000A3522	1	Euro 2	•	•					
1	800095960	1				•	•	•		
2	8000A2629	1		•	•					06540 I ► ► I 06742 07236 I ►
2	8000A2644	1	Euro 2	•	•					
2	800095961	1				•	•	•		
3	800086699	1		•	•					06540 I ► ► I 06742 07236 I ►
3	800086699	1				•	•	•		
4	8C0030362	1				•	•	•		
5	8000A0973	1		•	•					06540 I ► ► I 06742 07236 I ►
5	800096629	1				•	•	•		
6	8000A0370	1		•	•					06540 I ► ► I 06742 07236 I ►
6	800096618	1				•	•	•		
7	8000A2630	1		•	•					06540 I ► ► I 06742 07236 I ►
7	800095962	1				•	•	•		
8	8000A0975	1		•	•					06540 I ► ► I 06742 07236 I ►
8	66N221213	1				•	•	•		
9	8000A2631	1		•	•					06540 I ► ► I 06742 07236 I ►
9	800096586	1				•	•	•		
10	8D0081569	1		•	•					06540 I ► ► I 06742 07236 I ►
10	8000A0973	1	Euro 2	•	•					
10	8D0081569	1				•	•	•		
11	8A0025044	1		•	•					06540 I ► ► I 06742 07236 I ►
11	8000A0370	1	Euro 2	•	•					
11	8A0025044	1				•	•	•		
12	8000A2632	1		•	•					06540 I ► ► I 06742 07236 I ►
12	8000A3524	1	Euro 2	•	•					
12	800095964	1				•	•	•		
13	8000A2633	1		•	•					06540 I ► ► I 06742 07236 I ►



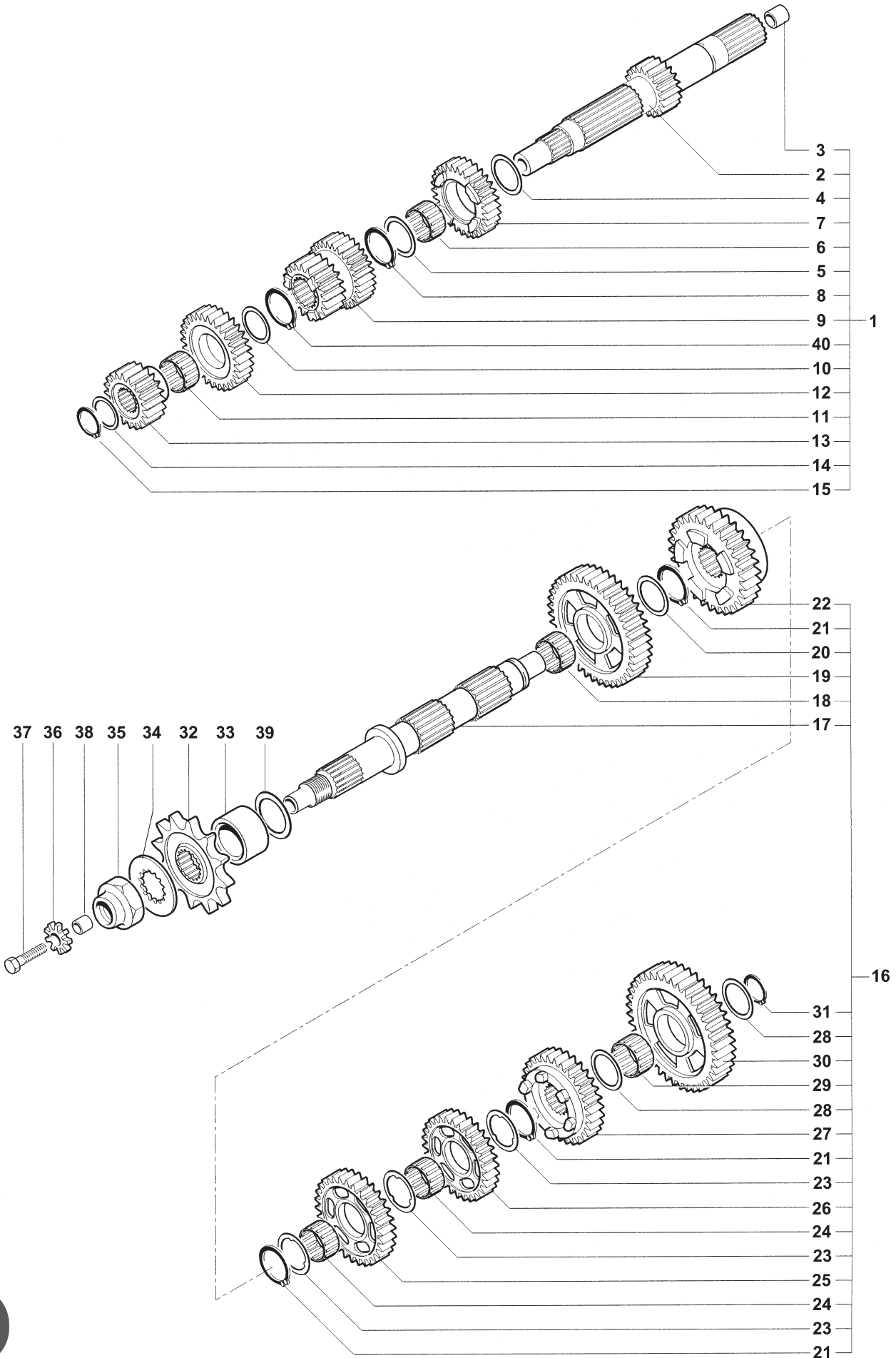

ASSIEME CAMBIO (F4 S / S 1+1 EV 03 - Euro 2 / SPR / SR / SENNA)

CHANGE GEAR ASSEMBLY (F4 S / S 1+1 EV 03 - Euro 2 / SPR / SR / SENNA) • ENSEMBLE BOÎTE DE VITESSE (F4 S / S 1+1 EV 03 - Euro 2 / SPR / SR / SENNA) • BAUGRUPPE GETRIEBE (F4 S / S 1+1 EV 03 - Euro 2 / SPR / SR / SENNA) • CONJUNTO CAMBIO (F4 S / S 1+1 EV 03 - Euro 2 / SPR / SR / SENNA)



ASSIEME CAMBIO (F4 S / S 1+1 EV 03 - Euro 2 / SPR / SR / SENNA)

 CHANGE GEAR ASSEMBLY (F4 S / S 1+1 EV 03 - Euro 2 / SPR / SR / SENNA) • ENSEMBLE BOÎTE DE VITESSE
 (F4 S / S 1+1 EV 03 - Euro 2 / SPR / SR / SENNA) • BAUGRUPPE GETRIEBE (F4 S / S 1+1 EV 03 - Euro 2 / SPR /
 SR / SENNA) • CONJUNTO CAMBIO (F4 S / S 1+1 EV 03 - Euro 2 / SPR / SR / SENNA)



N.	Code	Q.ty	Note	750 S	750 S 1+1	SPR	SR-SR1+1	SENNA	► I FRAME I ◄	► I ENGINE I ◄
13	8000A2645	1	Euro 2	•	•					
13	800095965	1				•	•	•		
14	8G0048590	1		•	•					06540 I► ► I 06742 07236 I►
14	8D0081569	1	Euro 2	•	•					
14	8G0048590	1				•	•	•		
15	66N221207	1		•	•					06540 I► ► I 06742 07236 I►
15	66N221210	1	Euro 2	•	•					
15	66N221207	1				•	•	•		
16	8000A2634	1		•	•					06540 I► ► I 06742 07236 I►
16	8000A3523	1	Euro 2	•	•					
16	800095966	1				•	•	•		
17	8000A0980	1		•	•					06540 I► ► I 06742 07236 I►
17	8000A1072	1	Euro 2	•	•					
17	800091901	1				•	•	•		
18	8000A0370	1		•	•					06540 I► ► I 06742 07236 I►
18	800096618	1				•	•	•		
19	8000A2635	1		•	•					06540 I► ► I 06742 07236 I►
19	8000A2650	1	Euro 2	•	•					
19	800095967	1				•	•	•		
20	8000A0982	1		•	•					06540 I► ► I 06742 07236 I►
20	8000A4196	1	Euro 2	•	•					
20	800096629	1				•	•	•		
21	8000A0990	3		•	•					06540 I► ► I 06742 07236 I►
21	66N221213	3				•	•	•		
22	8000A2636	1		•	•					06540 I► ► I 06742 07236 I►
22	800095968	1				•	•	•		
23	8000A0982	3		•	•					06540 I► ► I 06742 07236 I►
23	8000A4196	3	Euro 2	•	•					
23	800096629	3				•	•	•		
24	8000A0370	2		•	•					06540 I► ► I 06742 07236 I►
24	800096618	2				•	•	•		
25	8000A2637	1		•	•					06540 I► ► I 06742 07236 I►



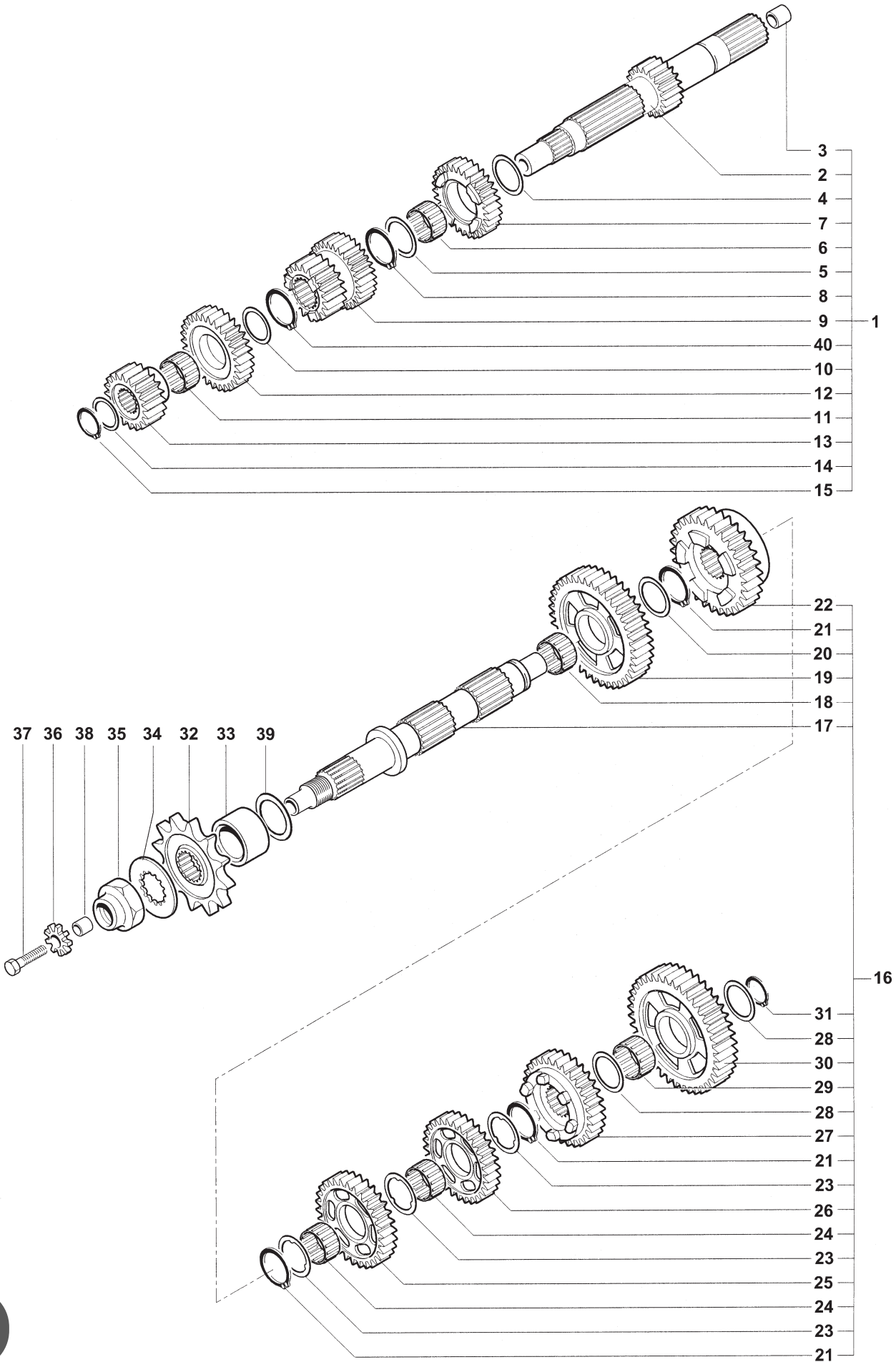

ASSIEME CAMBIO (F4 S / S 1+1 EV 03 - Euro 2 / SPR / SR / SENNA)

CHANGE GEAR ASSEMBLY (F4 S / S 1+1 EV 03 - Euro 2 / SPR / SR / SENNA) • ENSEMBLE BOÎTE DE VITESSE (F4 S / S 1+1 EV 03 - Euro 2 / SPR / SR / SENNA) • BAUGRUPPE GETRIEBE (F4 S / S 1+1 EV 03 - Euro 2 / SPR / SR / SENNA) • CONJUNTO CAMBIO (F4 S / S 1+1 EV 03 - Euro 2 / SPR / SR / SENNA)



ASSIEME CAMBIO (F4 S / S 1+1 EV 03 - Euro 2 / SPR / SR / SENNA)

 CHANGE GEAR ASSEMBLY (F4 S / S 1+1 EV 03 - Euro 2 / SPR / SR / SENNA) • ENSEMBLE BOÎTE DE VITESSE
 (F4 S / S 1+1 EV 03 - Euro 2 / SPR / SR / SENNA) • BAUGRUPPE GETRIEBE (F4 S / S 1+1 EV 03 - Euro 2 / SPR /
 SR / SENNA) • CONJUNTO CAMBIO (F4 S / S 1+1 EV 03 - Euro 2 / SPR / SR / SENNA)



N.	Code	Q.ty	Note	750 S	750 S 1+1	SPR	SR-SR1+1	SENNA	► I FRAME I ►	► I ENGINE I ►
25	800096592	1				•	•	•		
26	8000A2638	1		•	•					06540 I ► ► I 06742 07236 I ►
26	800095970	1				•	•	•		
27	8000A2639	1		•	•					06540 I ► ► I 06742 07236 I ►
27	800095971	1				•	•	•		
28	8000A0987	2		•	•					06540 I ► ► I 06742 07236 I ►
28	800096692	2				•	•	•		
29	8000A0370	1		•	•					06540 I ► ► I 06742 07236 I ►
29	8A0025044	1				•	•	•		
30	8000A2640	1		•	•					06540 I ► ► I 06742 07236 I ►
30	800095972	1				•	•	•		
31	66N221212	1		•	•					06540 I ► ► I 06742 07236 I ►
31	66N221210	1	Euro 2	•	•					
31	66N221210	1				•	•	•		
32	800098034	1		•	•					06540 I ► ► I 06742 07236 I ►
32	800098034	1				•	•	•		
33	8A0081466	1		•	•					06540 I ► ► I 06742 07236 I ►
33	8000A2319	1	Euro 2	•	•					
33	8A0081466	1				•	•	•		
34	800081451	1		•	•					06540 I ► ► I 06742 07236 I ►
34	800081451	1				•	•	•		
35	800091924	1		•	•					06540 I ► ► I 06742 07236 I ►
35	800091924	1				•	•	•		
36	800099064	1		•	•					06540 I ► ► I 06742 07236 I ►
36	800088343	1				•	•	•		
37	800062728	1		•	•					06540 I ► ► I 06742 07236 I ►
37	800062728	1				•	•	•		
38	800051549	1		•	•					06540 I ► ► I 06742 07236 I ►



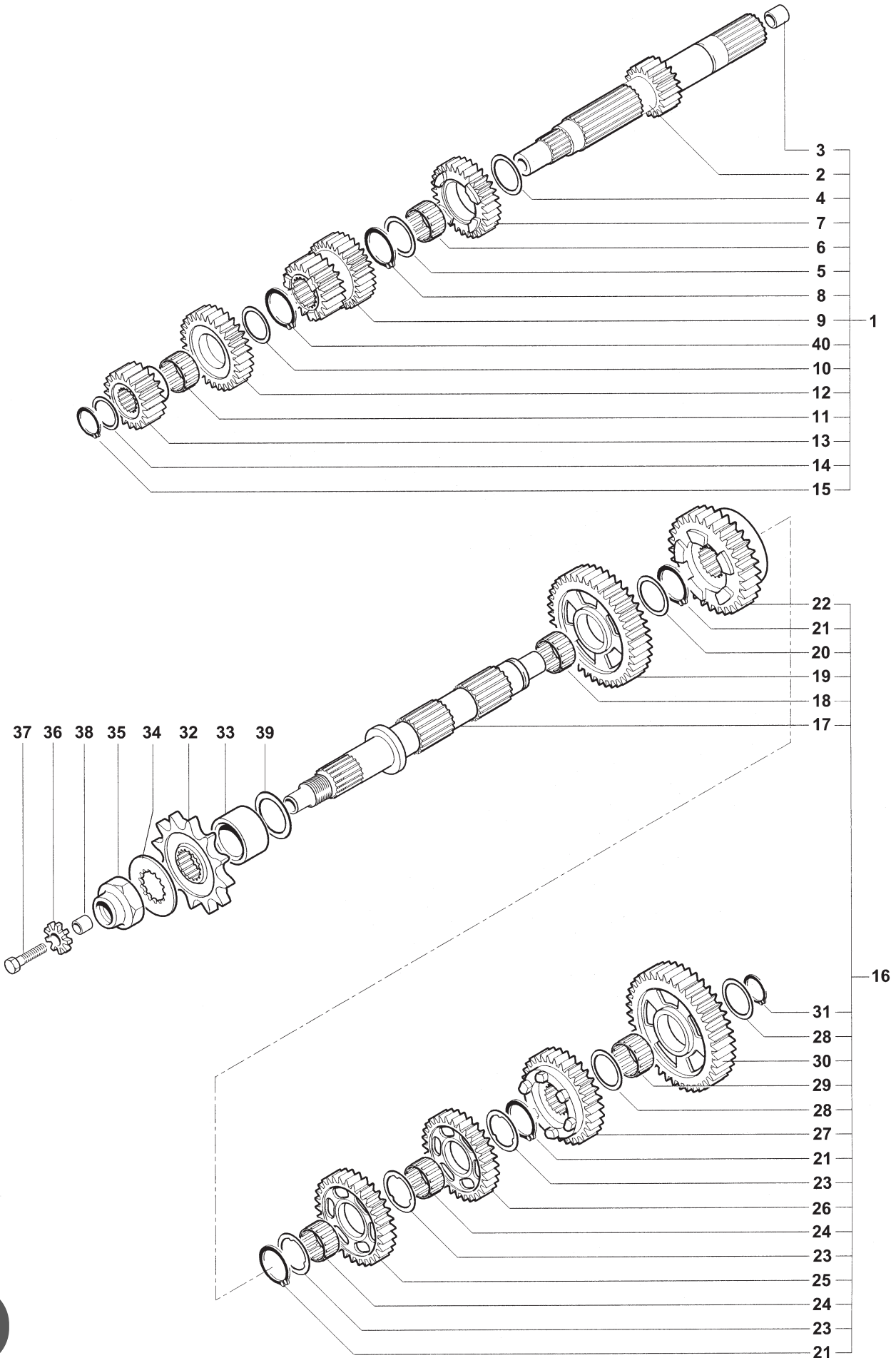

ASSIEME CAMBIO (F4 S / S 1+1 EV 03 - Euro 2 / SPR / SR / SENNA)

CHANGE GEAR ASSEMBLY (F4 S / S 1+1 EV 03 - Euro 2 / SPR / SR / SENNA) • ENSEMBLE BOÎTE DE VITESSE (F4 S / S 1+1 EV 03 - Euro 2 / SPR / SR / SENNA) • BAUGRUPPE GETRIEBE (F4 S / S 1+1 EV 03 - Euro 2 / SPR / SR / SENNA) • CONJUNTO CAMBIO (F4 S / S 1+1 EV 03 - Euro 2 / SPR / SR / SENNA)



ASSIEME CAMBIO (F4 S / S 1+1 EV 03 - Euro 2 / SPR / SR / SENNA)

 CHANGE GEAR ASSEMBLY (F4 S / S 1+1 EV 03 - Euro 2 / SPR / SR / SENNA) • ENSEMBLE BOÎTE DE VITESSE
 (F4 S / S 1+1 EV 03 - Euro 2 / SPR / SR / SENNA) • BAUGRUPPE GETRIEBE (F4 S / S 1+1 EV 03 - Euro 2 / SPR /
 SR / SENNA) • CONJUNTO CAMBIO (F4 S / S 1+1 EV 03 - Euro 2 / SPR / SR / SENNA)

N.	Code	Q.ty	Note	750 S	750 S 1+1	SPR	SR-SR1+1	SENNA	► I FRAME I ►	► I ENGINE I ►
38	800051549	1				•	•	•		
39	800096565	1	≠ 1.4	•	•					06540 I ► ► I 06742 07236 I ►
39	8000A1234	1	≠ 1.4 - Euro 2	•	•					
39	800096565	1	≠ 1.4			•	•	•		
39	8A0096565	1	≠ 1.5	•	•					06540 I ► ► I 06742 07236 I ►
39	8A00A1234	1	≠ 1.5 - Euro 2	•	•					
39	8A0096565	1	≠ 1.5			•	•	•		
39	8B0096565	1	≠ 1.6	•	•					06540 I ► ► I 06742 07236 I ►
39	8B00A1234	1	≠ 1.6 - Euro 2	•	•					
39	8B0096565	1	≠ 1.6			•	•	•		
40	8000A0975	1	Euro 2	•	•					





DOTAZIONI
OUTFIT • ÉQUIPEMENT
BORDWERKZEUG • EQUIPAMIENTO

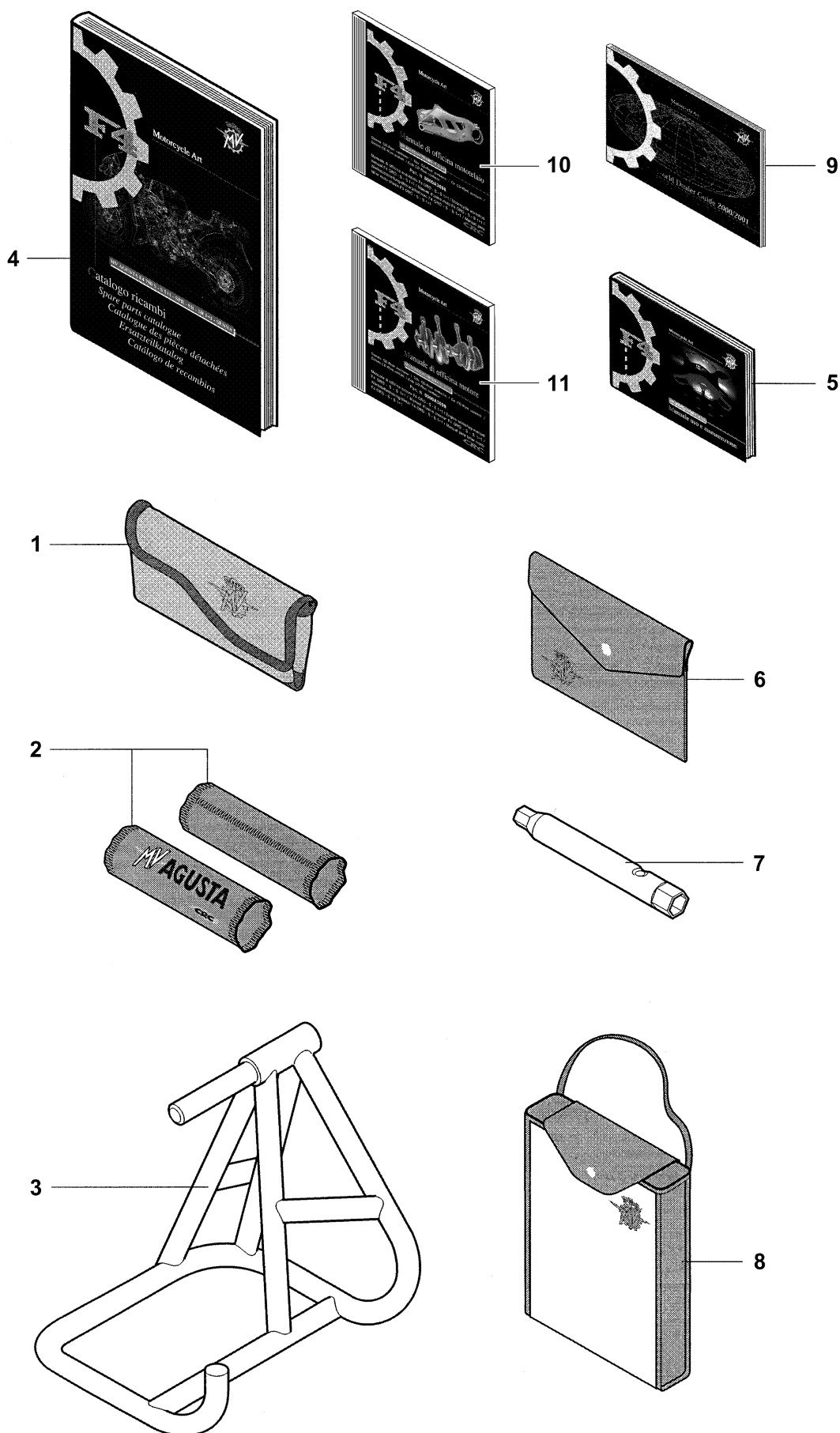



N.	Code	Q.ty	Note	750 S	S 1+1	SPR	SR-SR1+1	SENNÀ	Descrizione	Description	► I FRAME I ►	► I ENGINE I ►
1	800092850	1		•	•	•	•	•	Borsa attrezzi completa	Complete tool box		
2	800094318	2		•	•	•	•	•	Coprimanopola	Twist grip cover		
3	800092642	1		•	•	•	•	•	Cavalletto post.	Rear stand		
4	800098957	1		•	•	•	•	•	Catalogo ricambi	Spare parts catalogue		
5	800098956	1	I EV 02	•	•				Libretto uso e manutenzione	Use and maintenance manual	► I 004611	
5	8A0098956	1	GB EV 02	•	•				Libretto uso e manutenzione	Use and maintenance manual	► I 004611	
5	8B0098956	1	F EV 02	•	•				Libretto uso e manutenzione	Use and maintenance manual	► I 004611	
5	8C0098956	1	D EV 02	•	•				Libretto uso e manutenzione	Use and maintenance manual	► I 004611	
5	8D0098956	1	E EV 02	•	•				Libretto uso e manutenzione	Use and maintenance manual	► I 004611	
5	8A0098946	1	USA 1 EV 02	•					Owner's manual	Owner's manual	► I 100436	
5	8A0098946	1	USA 1 EV 02		•				Owner's manual	Owner's manual		
5	8000A1529	1	I EV 02	•	•				Libretto uso e manutenzione	Use and maintenance manual	004718 ►	
5	8A00A1529	1	GB EV 02	•	•				Libretto uso e manutenzione	Use and maintenance manual	004718 ►	
5	8B00A1529	1	F EV 02	•	•				Libretto uso e manutenzione	Use and maintenance manual	004718 ►	
5	8C00A1529	1	D EV 02	•	•				Libretto uso e manutenzione	Use and maintenance manual	004718 ►	
5	8D00A1529	1	E EV 02	•	•				Libretto uso e manutenzione	Use and maintenance manual	004718 ►	
5	8A00A1530	1	USA 1 EV 02	•					Owner's manual	Owner's manual	100437 ►	
5	8000A2533	1	I EV 03	•	•				Libretto uso e manutenzione	Use and maintenance manual		
5	8A00A2533	1	GB EV 03	•	•				Libretto uso e manutenzione	Use and maintenance manual		
5	8B00A2533	1	F EV 03	•	•				Libretto uso e manutenzione	Use and maintenance manual		
5	8C00A2533	1	D EV 03	•	•				Libretto uso e manutenzione	Use and maintenance manual		
5	8D00A2533	1	E EV 03	•	•				Libretto uso e manutenzione	Use and maintenance manual		
5	8000A2534	1	USA EV 03 Euro 2	•	•				Owner's manual	Owner's manual		
5	8000A3065	1	I Euro 2	•	•				Libretto uso e manutenzione	Use and maintenance manual		
5	8A00A3065	1	GB Euro 2	•	•				Libretto uso e manutenzione	Use and maintenance manual		
5	8B00A3065	1	F Euro 2	•	•				Libretto uso e manutenzione	Use and maintenance manual		
5	8C00A3065	1	D Euro 2	•	•				Libretto uso e manutenzione	Use and maintenance manual		
5	8D00A3065	1	E Euro 2	•	•				Libretto uso e manutenzione	Use and maintenance manual		





DOTAZIONI
OUTFIT • ÉQUIPEMENT
BORDWERKZEUG • EQUIPAMIENTO

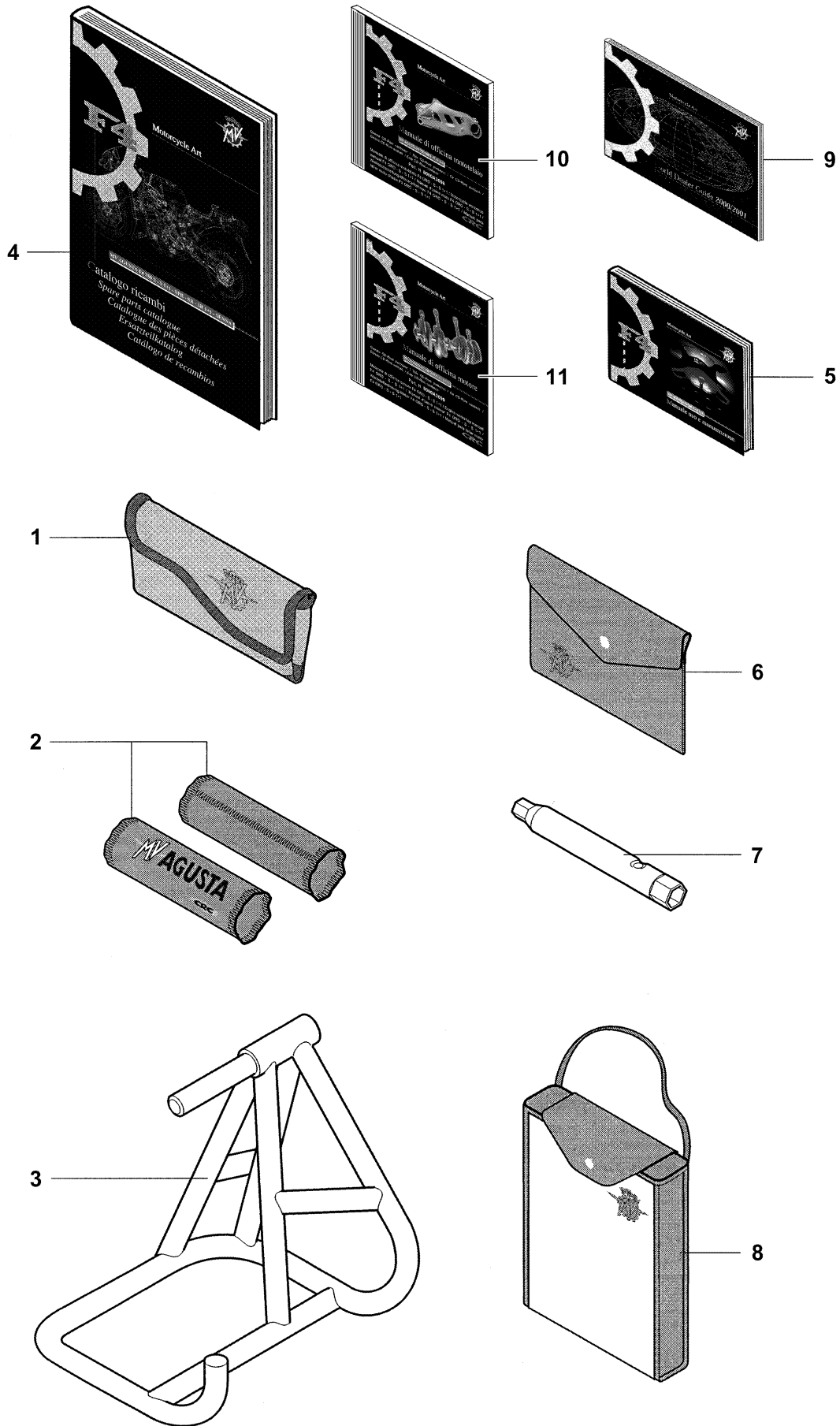



N.	Code	Q.ty	Note	750 S	S 1+1	SPR	SR-SR1+1	SENNA	Descrizione	Description	► I FRAME I ►	► I ENGINE I ►
5	8000A0960	1	I			•			Libretto uso e manutenzione	Use and maintenance manual		
5	8A00A0960	1	GB			•			Libretto uso e manutenzione	Use and maintenance manual		
5	8B00A0960	1	F			•			Libretto uso e manutenzione	Use and maintenance manual		
5	8C00A0960	1	D			•			Libretto uso e manutenzione	Use and maintenance manual		
5	8D00A0960	1	E			•			Libretto uso e manutenzione	Use and maintenance manual		
5	8000A0961	1	USA			•			Owner's manual	Owner's manual		
5	8000A3920	1	I				•		Libretto uso e manutenzione	Use and maintenance manual		
5	8A00A3920	1	GB				•		Libretto uso e manutenzione	Use and maintenance manual		
5	8B00A3920	1	F				•		Libretto uso e manutenzione	Use and maintenance manual		
5	8C00A3920	1	D				•		Libretto uso e manutenzione	Use and maintenance manual		
5	8D00A3920	1	E				•		Libretto uso e manutenzione	Use and maintenance manual		
5	8000A3921	1	USA				•		Owner's manual	Owner's manual		
5	8000A0958	1	I					•	Libretto uso e manutenzione	Use and maintenance manual		
5	8A00A0958	1	GB					•	Libretto uso e manutenzione	Use and maintenance manual		
5	8B00A0958	1	F					•	Libretto uso e manutenzione	Use and maintenance manual		
5	8C00A0958	1	D					•	Libretto uso e manutenzione	Use and maintenance manual		
5	8D00A0958	1	E					•	Libretto uso e manutenzione	Use and maintenance manual		
5	8A0098958	1	USA 1					•	Owner's manual	Owner's manual		
6	800093414	1		•	•	•	•	•	Portadocumenti	Document holder		
7	800089013	1		•	•	•	•	•	Chiave candela	Spark plug spanner		
8	800092853	1		•	•	•	•	•	Telo coprimoto	Tarpaulin		
9	800097886	1		•	•	•	•	•	World Dealer Guide	World Dealer Guide		
10	8000A3098	1		•	•	•	•	•	CD-Rom Manuale officina mototelaio	Motorcycle service manual CD-Rom		
11	8000A3099	1		•	•	•	•	•	CD-Rom Manuale officina motore	Workshop manual CD-Rom		





ATTREZZATURE DI SERVIZIO (CICLISTICA)

SERVICE TOOLS (FRAME) • MATÉRIEL (PARTIE CYCLE)

SPEZIALWERKZEUG (RAHMEN) • UTILLAJE DE SERVICIO (MOTOCICLETA)

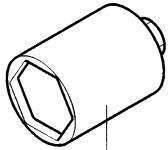

1

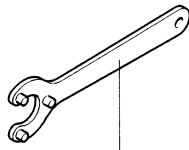

2

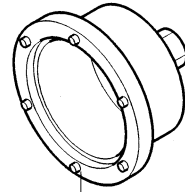

3

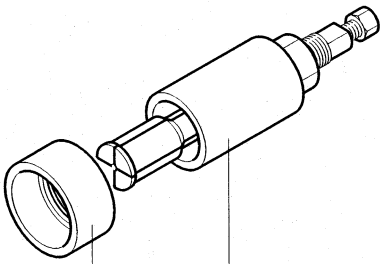

5

4

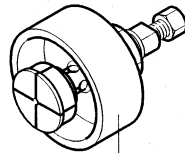

6



7

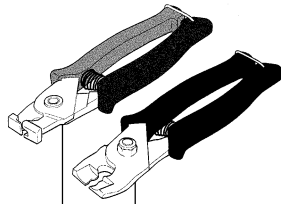

12

13

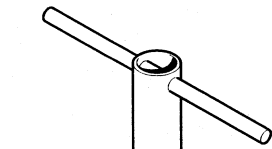

9

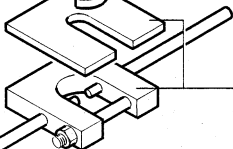

10

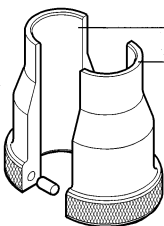

11

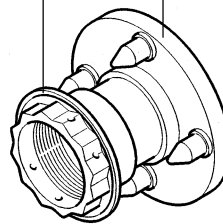

16

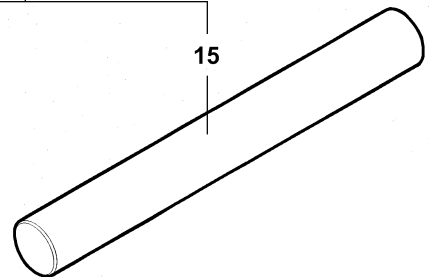

15

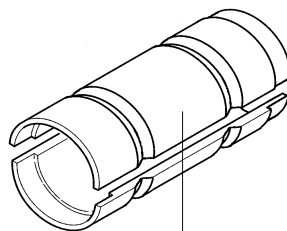

17

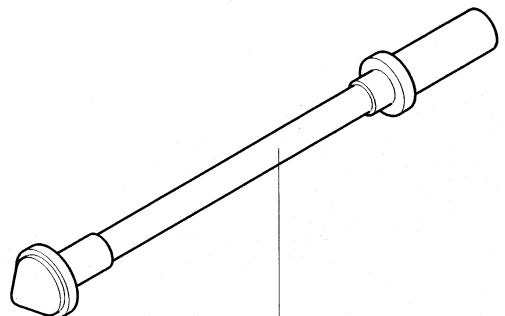

14

ATTREZZATURE DI SERVIZIO (CICLISTICA)
 SERVICE TOOLS (FRAME) • MATÉRIEL (PARTIE CYCLE)
 SPEZIALWERKZEUG (RAHMEN) • UTILLAJE DE SERVICIO (MOTOCICLETA)



N.	Code	Q.ty	Note	750 S	S 1+1	SPR	SR-SR1+1	SENNA	Descrizione	Description	► I FRAME I ►	► I ENGINE I ►
1	800092872	2		•	•	•	•	•	Chiave perno ruota anteriore	Front wheel spindle spanner		
2	800091645	1		•	•	•	•	•	Chiave ghiera cuscinetti sterzo	Steering bearing pin wrench		
3	800092857	1		•	•	•	•	•	Chiave ghiera eccentrico sterzo	Steering cam ring nut spanner		
4	800092860	1		•	•	•	•	•	Estrattore cuscinetti forcellone	Fork bearings puller		
5	800092861	1		•	•	•	•	•	Boccola estrattore cuscinetti forcellone	Fork bearings puller bushing		
6	800092862	1		•	•	•	•	•	Estrattore cuscinetti ruota anteriore	Front wheel bearings puller		
7	800092863	1		•	•	•	•	•	Chiave per CPC	CPC spanner		
8	800092864	1		•	•		•		Attrezzo sospensione anteriore	Front suspension tool		
8	800092864	1						•	Attrezzo sospensione anteriore	Front suspension tool	► I 004885	
8	800092864	1	USA					•	Attrezzo sospensione anteriore	Front suspension tool		
9	800094920	1		•	•		•		Attrezzo cartuccia	Cartridge tool		
9	800094920	1						•	Attrezzo cartuccia	Cartridge tool	► I 004885	
9	800094920	1	USA					•	Attrezzo cartuccia	Cartridge tool		
10	800094919	1		•	•		•		Attrezzo molla	Spring tool		
10	800094919	1						•	Attrezzo molla	Spring tool	► I 004885	
10	800094919	1	USA					•	Attrezzo molla	Spring tool		
11	800094918	1		•	•		•		Attrezzo para-polvere e paraolio	Dust cover and oil splash guard tool		
11	800094918	1						•	Attrezzo para-polvere e paraolio	Dust cover and oil splash guard tool	► I 004885	
11	800094918	1	USA					•	Attrezzo para-polvere e paraolio	Dust cover and oil splash guard tool		
12	800095850	1		•	•	•	•	•	Pinza monta/smonta fascette clic R	Pliers for CLIC R clamps assembly/disassembly		
13	800098321	1		•	•	•	•	•	Pinza inclinata monta fascette CLIC R	Clamp fitting pliers CLIC R		
14	800092866	1		•	•	•	•	•	Attrezzo montaggio pacco forcellone	Fork pack assembly tool		
15	8000A1953	1		•	•	•	•	•	Perno per albero di centraggio	Pin for centering shaft		
16	800092865	1		•	•	•	•	•	Attr. bilanciamento ruota posteriore	Rear wheel balancing tool		
17	8000A1039	1					•		Attrezzo para-polvere e paraolio	Dust cover and oil splash guard tool		
17	8000A1039	1	1					•	Attrezzo para-polvere e paraolio	Dust cover and oil splash guard tool	005464 I ►	

❶ Esclusi gli USA - USA excluded - Sauf les USA - Ausschließlich USA - Excluidos los USA

J01

2



ATTREZZATURE DI SERVIZIO (CICLISTICA)

SERVICE TOOLS (FRAME) • MATÉRIEL (PARTIE CYCLE)

SPEZIALWERKZEUG (RAHMEN) • UTILLAJE DE SERVICIO (MOTOCICLETA)

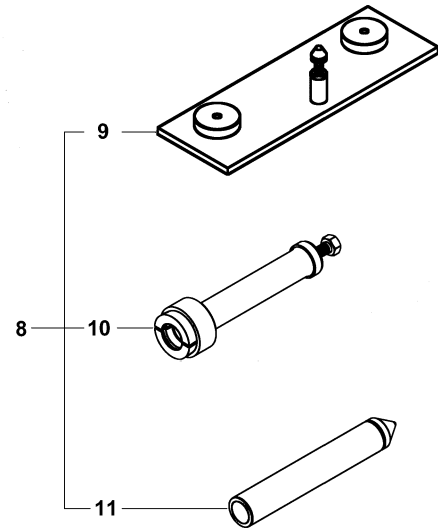
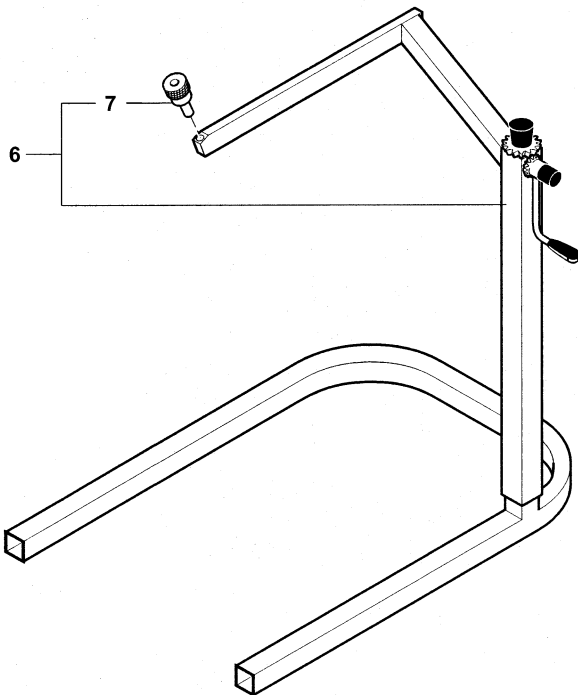
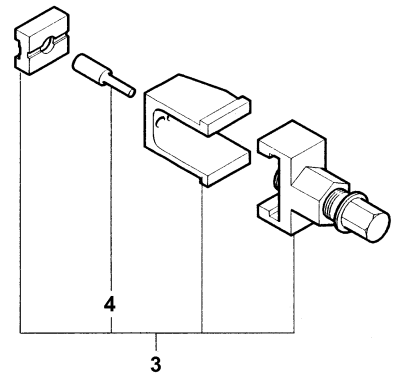
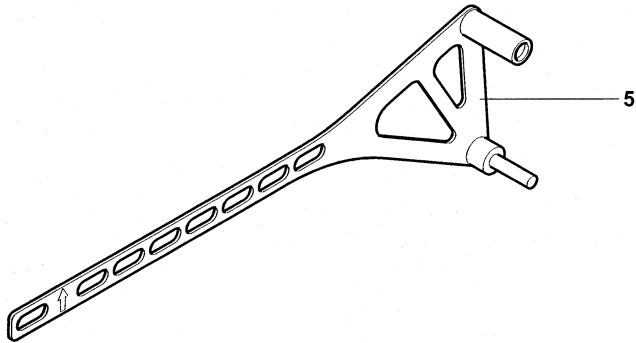
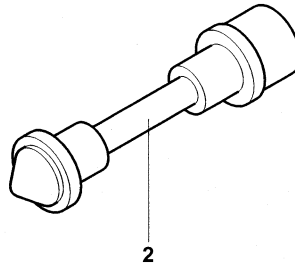
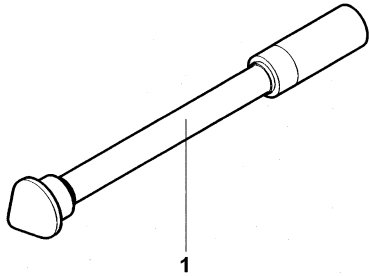

ATTREZZATURE DI SERVIZIO (CICLISTICA)

SERVICE TOOLS (FRAME) • MATÉRIEL (PARTIE CYCLE)

SPEZIALWERKZEUG (RAHMEN) • UTILLAJE DE SERVICIO (MOTOCICLETA)



N.	Code	Q.ty	Note	750 S	S 1+1	SPR	SR-SR1+1	SENNA	Descrizione	Description	► I FRAME I ►	► I ENGINE I ►
1	800092867	1		•	•	•	•	•	Attrezzo montaggio pacco bilanciere	Equaliser pack tool		
2	800092868	1		•	•	•	•	•	Attrezzo cuscinetti ruota anteriore	Front wheel bearings tool		
3	800095389	1		•	•	•	•	•	Attrezzo catena (passo 520:532)	Chain tool (pitch 520:532)		
4	800095390	1		•	•	•	•	•	Perno taglio e ribaditura (passo 520:532)	Cutting and riveting pin (pitch 520:532)		
5	800093347	1		•	•	•	•	•	Asta settaggio sospens. posteriore	Rear suspension setting rod		
6	800095807	1		•	•	•	•	•	Cavalletto anteriore	Front stand		
7	800095808	1		•	•	•	•	•	Perno cavalletto anteriore	Front stand pin		
8	800097887	1		•	•	•	•	•	Attrezzo cuscinetto perno di sterzo	Steering pin bearing tool		
9	800097888	1		•	•	•	•	•	Piastra di riscontro base di sterzo	Steering base plate		
10	800097889	1		•	•	•	•	•	Estrattore cuscinetto perno di sterzo	Steering pin bearing extractor		
11	800097890	1		•	•	•	•	•	Attrezzo montaggio cuscinetto perno di sterzo	Steering pin bearing assembly tool		



ATTREZZATURE DI SERVIZIO (MOTORE)

SERVICE TOOLS (ENGINE) • MATÉRIEL (MOTEUR)

SPEZIALWERKZEUG (MOTOR) • UTILLAJE DE SERVICIO (MOTOR)

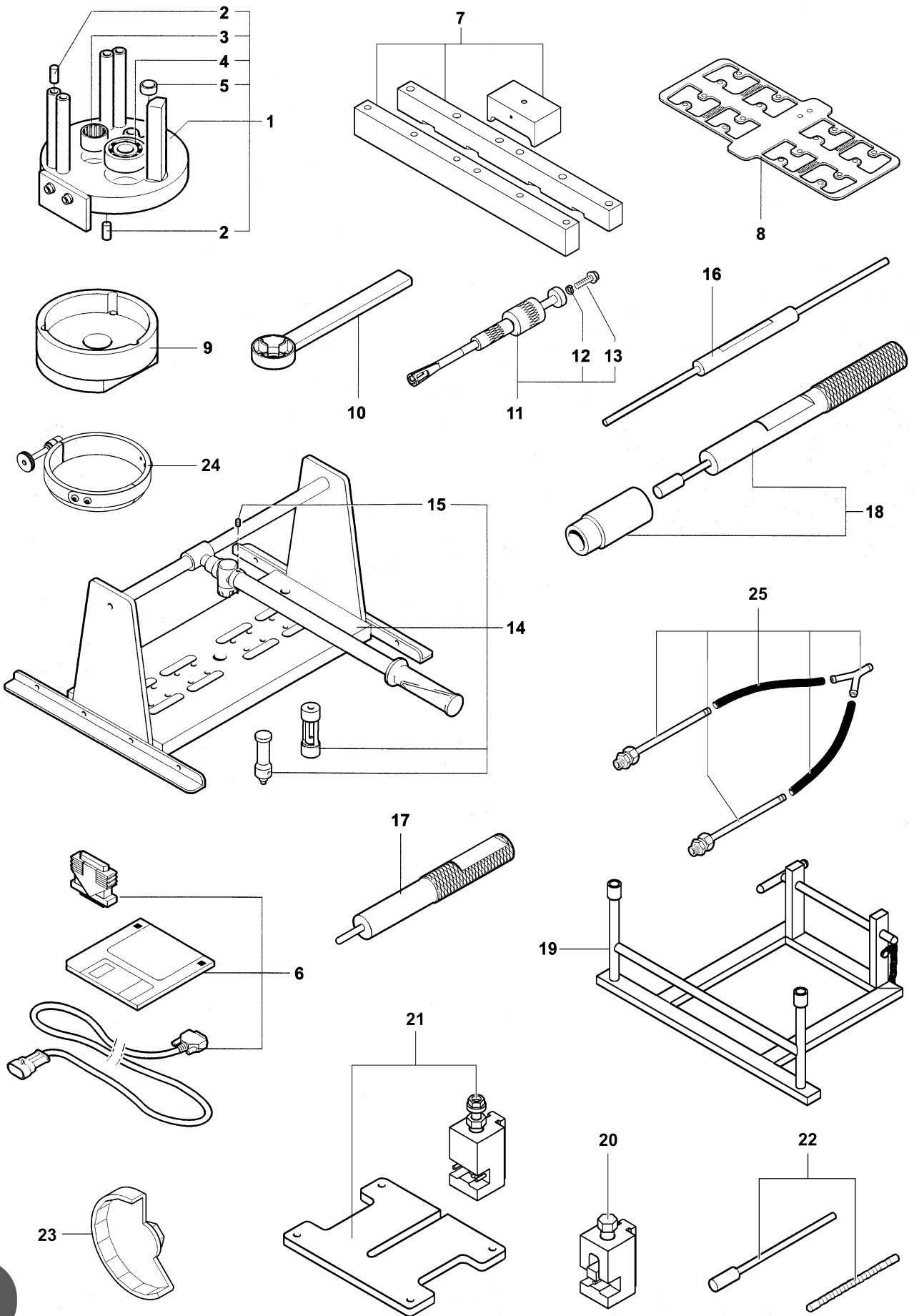

ATTREZZATURE DI SERVIZIO (MOTORE)
 SERVICE TOOLS (ENGINE) • MATÉRIEL (MOTEUR)
 SPEZIALWERKZEUG (MOTOR) • UTILLAJE DE SERVICIO (MOTOR)



N.	Code	Q.ty	Note	750 S	S 1+1	SPR	SR-SR1+1	SENNA	Descrizione	Description	► I FRAME I ►	► I ENGINE I ►
1	800094792	1		•	•	•	•	•	Attrezzo montaggio cambio	Gear change mounting tool		
2	800086119	8		•	•	•	•	•	Bussola di riferimento	Locating bush		
3	800081424	1		•	•	•	•	•	Cuscinetto	Bearing		
4	800086121	1		•	•	•	•	•	Cuscinetto	Bearing		
5	800087300	1		•	•	•	•	•	Cuscinetto	Bearing		
6	800093877	1		•	•	•	•	•	Software diagnostica	Diagnostics software		
7	8000A3406	1		•	•	•	•	•	Attrezzo misura sporgenza pistoni	Piston projection measuring tool		
8	800094797	1		•	•	•	•	•	Lastra sagomata copri testa	Head cover shaped plate		
9	800094795	1		•	•	•	•	•	Attrezzo bloccaggio rinvio albero alternatore	Alternator shaft transmission locking tool		
10	800094794	1		•	•	•	•	•	Attrezzo bloccaggio supporto parastrappi	Male flexible coupling support locking tool		
11	800094798	1		•	•	•	•	•	Attrezzo smontaggio gommini valvola	Valve rubber caps removal tool		
12	62N115538	1		•	•	•	•	•	Rosetta elastica	Spring washer		
13	8C0069056	3		•	•	•	•	•	Vite (TEF M8x30)	Screw (TEF M8x30)		
14	800094796	1		•	•	•	•	•	Attrezzo montaggio/ smontaggio valvole	Valve assembling/ disassembling tool		
15	800051521	2		•	•	•	•	•	Vite (M4x6 UNI 5923)	Screw (M4x6 UNI 5923)		
16	800095429	1		•	•	•	•	•	Tampone controllo	Gauge pad		
17	800095581	1		•	•	•	•	•	Punzone montaggio tenute valvola	Valve seals mounting punch		
18	8000A2385	1		•	•	•	•	•	Tampone montaggio guida	Guide mounting pad		
19	800097867	1		•	•	•	•	•	Supporto motore	Engine support		
20	8000A2280	1		•	•	•	•	•	Attrezzo chiusura catena distribuz.	Timing chain mounting tool		
21	8000A2281	1		•	•	•	•	•	Attrezzo apertura catena distribuz.	Timing chain cutting tool		
22	8000A2625	1		•	•	•	•	•	Broccia per guida valvole	Broach for valve guide		
23	800099010	1	①	•	•	•	•	•	Attrezzo smontaggio filtro olio	Oil filter removal tool		
23	8000A4317	1	②	•	•	•	•	•	Attrezzo smontaggio filtro olio	Oil filter removal tool		
24	8000A1432	1		•	•	•	•	•	Attrezzo stringifasce per montaggio pistoni	Piston ring assembly tool		
25	8000A4686	1		•	•	•	•	•	Attrezzatura per controllo CO	CO control tool assembly		

- ① Prima della sostituzione del Part. N° 31 - Tavola G06 • Before replacement of Part No. 31 - Table G06 • Avant de le remplacement du pièce N° 31 - Planche G06 • Bevor Wechsel von Teil Nr. 31 - Tafel G06 • Antes de la sustitución de la pieza N° 31 - Tabla G06.
- ② Dopo la sostituzione del part. N° 31 - Tavola G06 • After replacement of part No. 31 - Table G06 • Suite à le remplacement du pièce N° 31 - Planche G06 • Nach Wechsel von Teil Nr. 31 - Tafel G06 • Después de la sustitución de la pieza N° 31 - Tabla G06.



VARIANTI ESTERO

VERSIONS FOR FOREIGN COUNTRIES • VARIANTES ÉTRANGER
MODELLVARIANTEN AUSLAND • VARIANTES EXTRANJERO

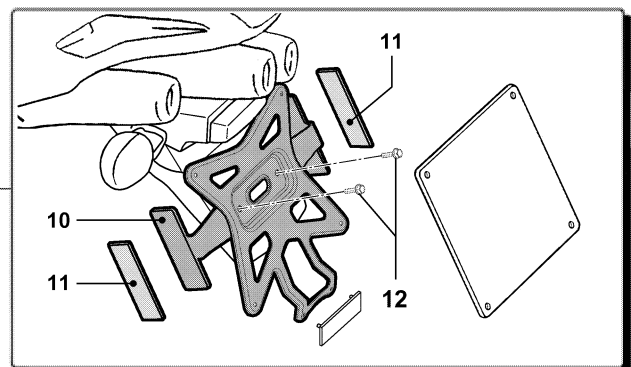
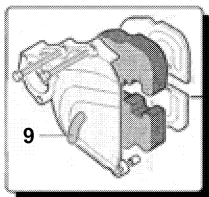
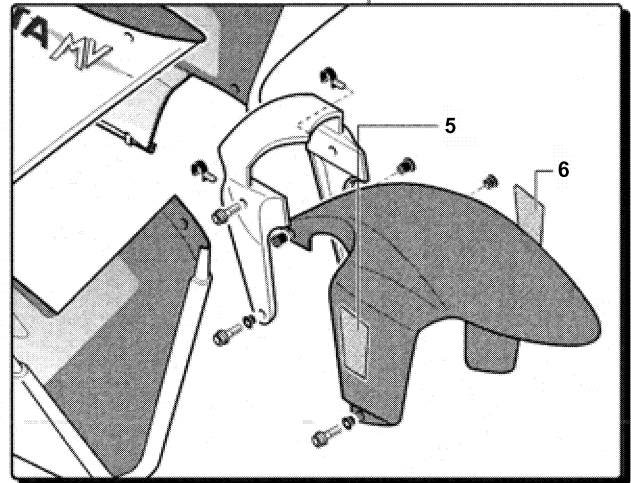
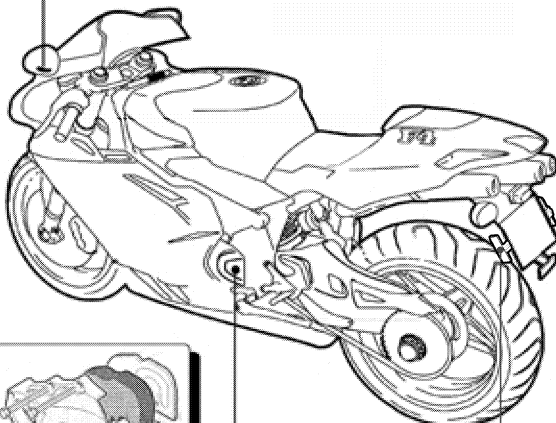
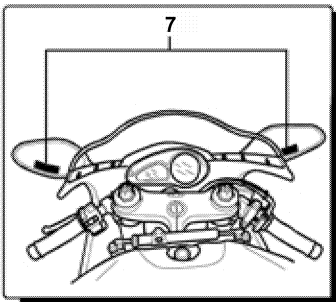
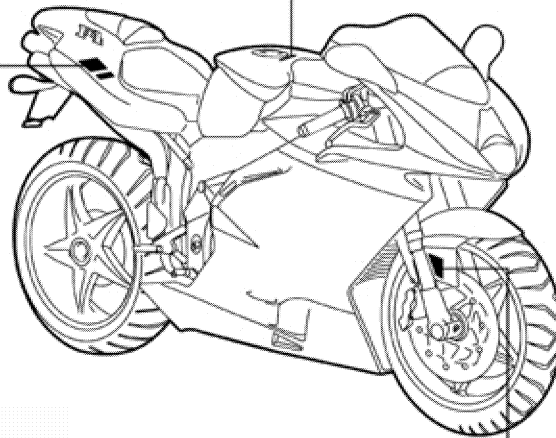
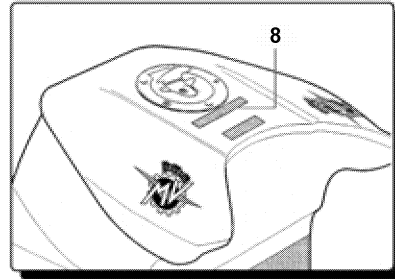
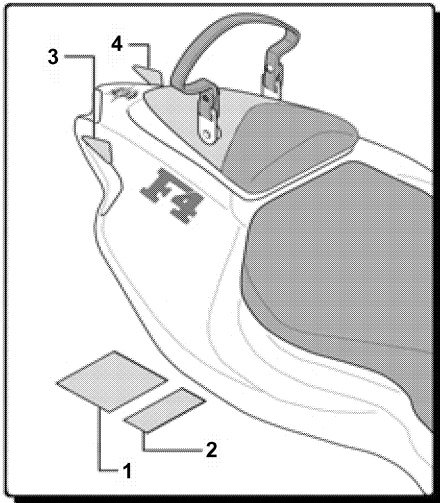

VARIANTI ESTERO

 VERSIONS FOR FOREIGN COUNTRIES • VARIANTES ÉTRANGER
 MODELLVARIANTEN AUSLAND • VARIANTES EXTRANJERO

N.	Code	Q.ty	Note	750 S	S 1+1	SPR	SR-SR1+1	SENNA	Descrizione	Description	► I FRAME I ►	► I ENGINE I ►
1	8000A0925	1	USA 1	•	•				Targhetta "Informazioni controllo emissioni"	Decal for "Vehicle emission control information"		
1	800098952	1	USA EV 02 EV 03	•	•				Targhetta "Informazioni controllo emissioni"	Decal for "Vehicle emission control information"		
1	8000A3056	1	USA Euro 2	•	•				Targhetta "Informazioni controllo emissioni"	Decal for "Vehicle emission control information"		
1	800099444	1	USA				•	•	Targhetta "Informazioni controllo emissioni"	Decal for "Vehicle emission control information"		
1	8000A0956	1	USA 1					•	Targhetta "Informazioni controllo emissioni"	Decal for "Vehicle emission control information"		
2	800094018	1	USA	•	•				Targhetta "Controllo emissioni"	Decal for "Noise emission control information"		
2	8A0094018	1	USA				•	•	Targhetta "Controllo emissioni"	Decal for "Noise emission control information"		
3	800095486	1	USA	•	•	•	•	•	Catadiottro destro per codone	Right reflector for tail piece		
4	800095487	1	USA	•	•	•	•	•	Catadiottro sinistro per codone	Left reflector for for tail piece		
5	800095484	1	USA	•	•	•	•	•	Catadiottro destro per parafango ant.	Right reflector front mudguard		
6	800095485	1	USA	•	•	•	•	•	Catadiottro sinistro per parafango ant.	Left reflector for front mudguard		
7	800094019	2	USA	•	•	•	•	•	Decal specchietto retrovisore	Decal for "Rear mirror"		
8	800095366	1	AUS	•	•	•	•	•	Targhetta "Benzina verde"	Decal for "Unleaded fuel"		
9	800095842	1	JPN	•	•	•	•	•	Targhetta "Ordine marce"	Decal for "The order of gear"		
10	8000A1825	1	AUS	•	•	•	•	•	Flangia portatarga/ catadiottri	Number plate holder/retro- reflectors flange		
11	80B073832	2	AUS	•	•	•	•	•	Catadiottro	Retroreflector		
12	800062726	2	AUS	•	•	•	•	•	Vite (TEF M6x14)	Screw (TEF M6x14)		



ASSIEME CANISTER (USA)

CARBON CANISTER ASSEMBLY (USA) • ENSEMBLE CANISTER (USA)
BAUGRUPPE CARBONKANISTER (USA) • CONJUNTO CANISTER (USA)

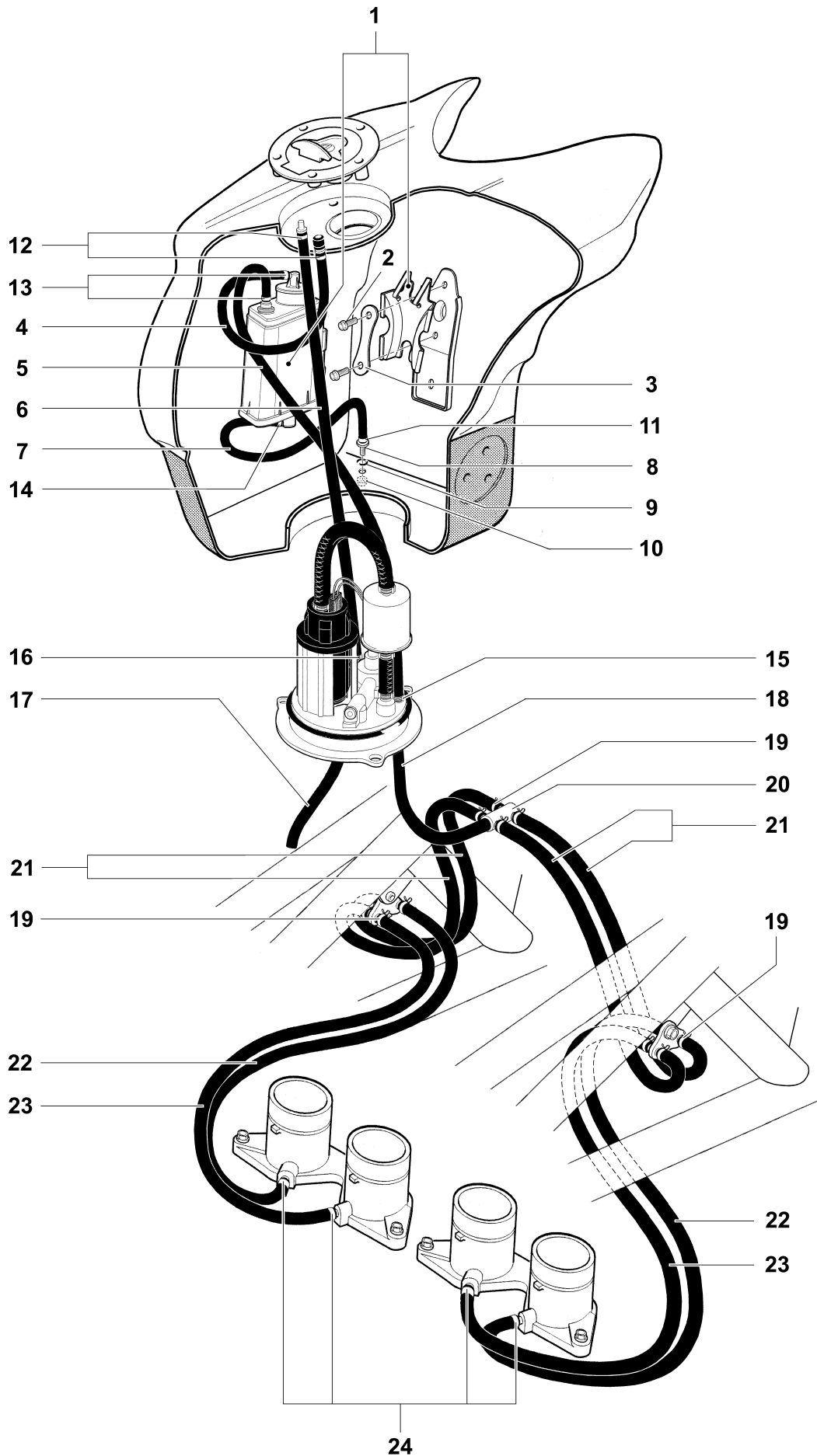

ASSIEME CANISTER (USA)

 CARBON CANISTER ASSEMBLY (USA) • ENSEMBLE CANISTER (USA)
 BAUGRUPPE CARBONKANISTER (USA) • CONJUNTO CANISTER (USA)

N.	Code	Q.ty	Note	750 S	750 S 1+1	SPR	SR-SR1+1	SENNA	► I FRAME I ►	► I ENGINE I ►
1	800097083	1	USA 1	•	•	•	•	•		
2	8D0067997	2	USA 1	•	•	•	•	•		
3	800097086	1	USA 1	•	•	•	•	•		
4	800098714	1	USA 1	•	•	•	•	•		
5	800097089	1	USA 1	•	•	•	•	•		
6	800090940	1	USA 1	•	•	•	•	•		
7	8A0090940	1	USA 1	•	•	•	•	•		
8	800095839	1	USA 1	•	•	•	•	•		
9	8A0023116	1	USA 1	•	•	•	•	•		
10	80B043928	1	USA 1	•	•	•	•	•		
11	8A0092256	1	USA 1	•	•	•	•	•		
12	8B0091687	2	USA 1	•	•	•	•	•		
13	800096458	2	USA 1	•	•	•	•	•		
14	8A0092256	1	USA 1	•	•	•	•	•		
15	8B0092256	1	USA 1	•	•	•	•	•		
16	8C0092256	1	USA 1	•	•	•	•	•		
17	800098950	1	USA 1	•	•	•	•	•		
18	800098715	1	USA 1	•	•	•	•	•		
19	8A0091634	12	USA 1	•	•	•	•	•		
20	800097088	1	USA 1	•	•	•	•	•		
21	800097090	4	USA 1	•	•	•	•	•		
22	800091037	2	USA 1	•	•	•	•	•		
23	8A0091037	2	USA 1	•	•	•	•	•		
24	800096458	4	USA 1	•	•	•	•	•		

1 Solo per moto USA (50 Stati) - Only for USA (50 States) bikes - Seulement pour les motos USA (50 États) - Nur für USA-50 Staaten Motorräder - Solamente para las motos de los USA (50 Estados).

INDICE CODICI / DENOMINAZIONI

CODEX / DESIGNATION INDEX • INDEX CODES / DÉNOMINATIONS

INHALTSVERZEICHNIS CODE • ÍNDICE CÓDIGOS / DENOMINACIONES

Code	Denominazione	Description	Désignation	Bezeichnung	Descripción	Table	N°
60N102467	VITE M4X25	SCREW M4X25	VIS M4X25	SCHRAUBE M4X25	TORNILLO M4X25	F04	14
60N102482	VITE M5X10	SCREW M5X10	VIS M5X10	SCHRAUBE M5X10	TORNILLO M5X10	E04	4
						E05	4
60N102509	VITE M6X20	SCREW M6X20	VIS M6X20	SCHRAUBE M6X20	TORNILLO M6X20	G14	13
60N102513	VITE M6X40	SCREW M6X40	VIS M6X40	SCHRAUBE M6X40	TORNILLO M6X40	G09	10
60N102517	VITE M6X60	SCREW M6X60	VIS M6X60	SCHRAUBE M6X60	TORNILLO M6X60	D03	17
						D04	7
60N102558	VITE M8X35	SCREW M8X35	VIS M8X35	SCHRAUBE M8X35	TORNILLO M8X35	G02	9
60N103834	VITE M6X14	SCREW M6X14	VIS M6X14	SCHRAUBE M6X14	TORNILLO M6X14	G11	6
60N107335	VITE M6X16	SCREW M6X16	VIS M6X16	SCHRAUBE M6X16	TORNILLO M6X16	G09	10
60N402562	VITE M8X55	SCREW M8X55	VIS M8X55	SCHRAUBE M8X55	TORNILLO M8X55	G01	54
61ND15064	DADO M8	NUT M8	ECROU M8	MUTTER M8	TUERCA M8	A01	21
61N115062	DADO M6	NUT M6	ECROU M6	MUTTER M6	TUERCA M6	D02	26
62N015676	ROSETTA	WASHER	RONDELLE	UNTERLEGSCHIEBE	ARANDELA	G15	17
62N015682	ROSETTA	WASHER	RONDELLE	UNTERLEGSCHIEBE	ARANDELA	G01	37
62N115538	ROSETTA ELASTICA	SPRING WASHER	RONDELLE ELASTIQUE	FEDERRING	ARANDELA ELASTICA	J03	12
62N115548	ROSETTA	WASHER	RONDELLE	UNTERLEGSCHIEBE	ARANDELA	E04	32
						E05	25
						F02	12
66N021203	ANELLO ELASTICO	SNAP RING	CIRCLIP	SPRENGRING	ARO	G06	2
66N021272	ANELLO ELASTICO	SNAP RING	CIRCLIP	SPRENGRING	ARO	G14	12
66N021313	ANELLO ELASTICO	SNAP RING	CIRCLIP	SPRENGRING	ARO	G05	3
66N221202	ANELLO ELASTICO	SNAP RING	CIRCLIP	SPRENGRING	ARO	G07	8
66N221207	ANELLO ELASTICO	SNAP RING	CIRCLIP	SPRENGRING	ARO	G10	14
						G17	15
66N221209	ANELLO ELASTICO	SNAP RING	CIRCLIP	SPRENGRING	ARO	G10	30
66N221210	ANELLO ELASTICO	SNAP RING	CIRCLIP	SPRENGRING	ARO	G17	15
						G17	31
66N221212	ANELLO ELASTICO	SNAP RING	CIRCLIP	SPRENGRING	ARO	G17	31
66N221213	ANELLO ELASTICO	SNAP RING	CIRCLIP	SPRENGRING	ARO	G10	20
						G17	8
						G17	21
66N221262	ANELLO ELASTICO	SNAP RING	CIRCLIP	SPRENGRING	ARO	G07	6
6BN021507	SFERA D 1/4"	BALL D 1/4"	BILLE D 1/4"	KUGEL Ø 1/4"	ESFERA D 1/4"	A03	32
800001199	ANELLO DI TENUTA	GROMMET	BAGUE D'ETANCHEITE	DICHTUNGSRING	RETEN	D02	29
800007719	BOCCOLA DI CENTRAGGIO	CENTERING BUSH	PION DE CENTRAGE	ZENTRIERBUCHSE	CASQUILLO DE CENTRAJE	G01	12
						G01	52
800017679	ANELLO DI TENUTA	GROMMET	BAGUE D'ETANCHEITE	DICHTUNGSRING	RETEN	G07	19
						G08	61
800018422	ANELLO DI TENUTA	GROMMET	BAGUE D'ETANCHEITE	DICHTUNGSRING	RETEN	G05	18
800019590	RULLINO D5X23.8	NEEDLE D5X23.8	PION D5X23.8	STIFT Ø 5X23.8	RODILLO D5X23.8	G06	6
800019789	ANELLO DI TENUTA	GROMMET	BAGUE D'ETANCHEITE	DICHTUNGSRING	RETEN	B06	16
						B07	16
800019965	ANELLO DI TENUTA	GROMMET	BAGUE D'ETANCHEITE	DICHTUNGSRING	RETEN	G13	18
800019971	RULLINO D4X15.8	NEEDLE D4X15.8	PION D4X15.8	STIFT Ø 4X15.8	RODILLO D4X15.8	G02	8
800021480	ROSETTA	WASHER	RONDELLE	UNTERLEGSCHIEBE	ARANDELA	D02	36
						D03	23
						D04	15
						E03	17
						G12	3
						G16	6
800022551	ANELLO DI TENUTA	GROMMET	BAGUE D'ETANCHEITE	DICHTUNGSRING	RETEN	G15	12
800023106	ANELLO DI TENUTA	GROMMET	BAGUE D'ETANCHEITE	DICHTUNGSRING	RETEN	G06	30
800023107	ANELLO DI TENUTA	GROMMET	BAGUE D'ETANCHEITE	DICHTUNGSRING	RETEN	F03	22
800023108	ANELLO DI TENUTA	GROMMET	BAGUE D'ETANCHEITE	DICHTUNGSRING	RETEN	G06	17
800023116	ANELLO DI TENUTA	GROMMET	BAGUE D'ETANCHEITE	DICHTUNGSRING	RETEN	G01	34
800028327	VITE M6X14	SCREW M6X14	VIS M6X14	SCHRAUBE M6X14	TORNILLO M6X14	G01	24
						G11	6

INDICE CODICI / DENOMINAZIONI

 CODEX / DESIGNATION INDEX • INDEX CODES / DÉNOMINATIONS
 INHALTSVERZEICHNIS CODE • ÍNDICE CÓDIGOS / DENOMINACIONES

Code	Denominazione	Description	Désignation	Bezeichnung	Descripción	Table	N°
800031113	ROSETTA	WASHER	RONDELLE	UNTERLEGSCHEIBE	ARANDELA	B06	2
						B07	2
800033552	SPURGO	DRAIN VALVE	VIS DE PURGE	ENTLÜFTUNGSSCHRAUBE	ESPURGO	D04	14
800034317	CUSCINETTO	BEARING	ROULEMENT	LAGER	COJINETE	G07	4
						G09	7
800035006	CUSCINETTO	BEARING	ROULEMENT	LAGER	COJINETE	G10	28
800035408	VITE M3X8	SCREW M3X8	VIS M3X8	SCHRAUBE M3X8	TORNILLO M3X8	G06	13
						G08	39
800035809	ANELLO DI TENUTA	GROMMET	BAGUE D'ETANCHEITE	DICHTUNGSRING	RETEN	G07	11
800036137	ROSETTA	WASHER	RONDELLE	UNTERLEGSCHEIBE	ARANDELA	G04	24
800036230	LAMPADA	BULB	AMPOULE	LAMPE	LAMPARA	F03	15
800036726	LAMPADA	BULB	AMPOULE	LAMPE	LAMPARA	F07	14
800037290	VITE AUTOFILETTANTE 2,9X16	TAPPING SCREW 2,9X16	VIS TARAUD 2,9X16	BLECHSCHRAUBE 2,9X16	TORNILLO AUTORROSCANTE 2,9X16	F01	9
800037901	DADO M6	NUT M6	ECROU M6	MUTTER M6	TUERCA M6	F04	20
						F06	16
800038520	RULLINO D4X8	NEEDLE D4X8	PION D4X8	STIFT Ø 4X8	RODILLO D4X8	G06	14
						G11	19
800038624	DADO M10	NUT M10	ECROU M10	MUTTER M10	TUERCA M10	G14	9
800039335	ROSETTA	WASHER	RONDELLE	UNTERLEGSCHEIBE	ARANDELA	G15	10
800040872	ANELLO DI TENUTA	GROMMET	BAGUE D'ETANCHEITE	DICHTUNGSRING	RETEN	G01	35
800041874	ANTIVIBRANTE	VIBRATION-DAMPER	ANTI-VIBRATIONS	SCHWINGUNGSDÄMPFER	ANTIVIBRANTE	G08	24
800042022	DADO M10	NUT M10	ECROU M10	MUTTER M10	TUERCA M10	B02	16
800042023	DADO M12	NUT M12	ECROU M12	MUTTER M12	TUERCA M12	A01	16
800042278	DADO M5	NUT M5	ECROU M5	MUTTER M5	TUERCA M5	G08	7
						G08	16
800044014	VITE M6X20	SCREW M6X20	VIS M6X20	SCHRAUBE M6X20	TORNILLO M6X20	F01	13
800044099	BUSSOLA	BUSH	DOUILLE	HÜLSE	CASQUILLO	F04	15
800044240	DADO M6	NUT M6	ECROU M6	MUTTER M6	TUERCA M6	A02	20
						A03	22
						G16	14
800047470	FUSIBILE 7,5 A	FUSE 7,5 A	FUSIBLE 7,5 A	SICHERUNG 7,5 A	FUSIBLE 7,5 A	F06	2
800047472	FUSIBILE 15A	FUSE 15A	FUSIBLE 15A	SICHERUNG 15A	FUSIBLE 15A	F06	3
800047763	ROSETTA	WASHER	RONDELLE	UNTERLEGSCHEIBE	ARANDELA	G06	24
800048245	DADO ELASTICO M6	SPRING NUT M6	ECROU AUTOFREINE M6	ELASTISCHE MUTTER M6	TUERCA ELASTICA M6	A02	13
						A03	13
						B01	10
						E01	2
						E02	28
						F03	3
						F07	16
						G08	21
800048551	CUSCINETTO	BEARING	ROULEMENT	LAGER	COJINETE	G14	4
800050679	ANELLO DI TENUTA	GROMMET	BAGUE D'ETANCHEITE	DICHTUNGSRING	RETEN	B06	6
						B07	6
800051191	CUSCINETTO	BEARING	ROULEMENT	LAGER	COJINETE	G11	10
800051521	VITE M4X6	SCREW M4X6	VIS M4X6	SCHRAUBE M4X6	TORNILLO M4X6	J03	15
800051549	BOCCOLA	BUSH	DOUILLE	BUCHSE	CASQUILLO	G04	5
						G07	17
						G10	37
						G11	38
						G17	38
800053724	FASCETTA IN GOMMA	RUBBER CLAMP	COLLIER EN CAOUTCHOUC	GUMMISCHELLE	CINTA DE GOMA	E04	10
						E05	10
						F01	21
						F04	21
						F05	4
						F06	12
						F06	23

INDICE CODICI / DENOMINAZIONI

CODEX / DESIGNATION INDEX • INDEX CODES / DÉNOMINATIONS

INHALTSVERZEICHNIS CODE • ÍNDICE CÓDIGOS / DENOMINACIONES

Code	Denominazione	Description	Désignation	Bezeichnung	Descripción	Table	N°						
800056359	ROSETTA	WASHER	RONDELLE	UNTERLEGSCHIEBE	ARANDELA	E04	22						
						E05	41						
						F07	8						
800056443	DADO M5	NUT M5	ECROU M5	MUTTER M5	TUERCA M5	E04	9						
						E05	9						
						F07	21						
800056444	FASCETTA IN NYLON	NYLON CLAMP	COLLIER EN NYLON	NYLONSCHELLE	CINTA DE NYLON	F06	11						
						G13	8						
800060577	VITE M6X20	SCREW M6X20	VIS M6X20	SCHRAUBE M6X20	TORNILLO M6X20	G01	55						
800062651	ANTIVIBRANTE	VIBRATION-DAMPER	ANTI-VIBRATIONS	SCHWINGUNGSDÄMPFER	ANTIVIBRANTE	A01	31						
						G08	12						
						G16	17						
800062652	BUSSOLA	BUSH	BAGUE	HÜLSE	CASQUILLO	G08	3						
800062724	ANTIVIBRANTE	VIBRATION-DAMPER	ANTI-VIBRATIONS	SCHWINGUNGSDÄMPFER	ANTIVIBRANTE	G08	69						
800062725	VITE M6X10	SCREW M6X10	VIS M6X10	SCHRAUBE M6X10	TORNILLO M6X10	A01	4						
						D01	12						
						D02	12						
						E04	23						
						F02	4						
						G01	51						
						G08	8						
						G08	17						
						800062726	VITE M6X14	SCREW M6X14	VIS M6X14	SCHRAUBE M6X14	TORNILLO M6X14	D02	43
												E02	8
G05	9												
G06	16												
G08	29												
G11	15												
G11	28												
G14	1												
K01	12												
800062727	VITE M6X16	SCREW M6X16	VIS M6X16	SCHRAUBE M6X16	TORNILLO M6X16							A01	34
						A02	14						
						A02	17						
						A03	14						
						A03	19						
						D02	38						
						E03	20						
						F02	6						
						F04	16						
						G05	16						
						G07	16						
						G07	21						
						800062728	VITE M6X20	SCREW M6X20	VIS M6X20	SCHRAUBE M6X20	TORNILLO M6X20	A01	12
D02	32												
E04	2												
E05	2												
F07	19												
G01	43												
G05	11												
G06	12												
G06	27												
G08	4												
G08	51												
G08	62												
G09	14												
G10	36												
G17	37												

INDICE CODICI / DENOMINAZIONI

 CODEX / DESIGNATION INDEX • INDEX CODES / DÉNOMINATIONS
 INHALTSVERZEICHNIS CODE • ÍNDICE CÓDIGOS / DENOMINACIONES

Code	Denominazione	Description	Désignation	Bezeichnung	Descripción	Table	N°
800062729	VITE M6X25	SCREW M6X25	VIS M6X25	SCHRAUBE M6X25	TORNILLO M6X25	G01	11
						G05	19
						G08	13
						G11	40
						G15	8
800062730	VITE M6X30	SCREW M6X30	VIS M6X30	SCHRAUBE M6X30	TORNILLO M6X30	G01	32
						G01	32
800062738	ROSETTA	WASHER	RONDELLE	UNTERLEGSCHEIBE	ARANDELA	E01	37
800064296	ANELLO DI TENUTA	GROMMET	BAGUE D'ETANCHEITE	DICHTUNGSRING	RETEN	G11	9
800064988	ROSETTA	WASHER	RONDELLE	UNTERLEGSCHEIBE	ARANDELA	G01	10
						G03	6
						G05	12
						G07	15
800065814	PARAOLIO	OIL SEAL	JOINT A LEVRE	ÖHLDIHTRING	RETENEDOR DE ACEITE	G04	7
800066308	ANTIVIBRANTE	VIBRATION-DAMPER	ANTI-VIBRATIONS	SCHWINGUNGSDÄMPFER	ANTIVIBRANTE	A02	16
						A03	18
800066339	ANTIVIBRANTE	VIBRATION-DAMPER	ANTI-VIBRATIONS	SCHWINGUNGSDÄMPFER	ANTIVIBRANTE	A02	12
						A03	12
800067412	BUSSOLA	BUSH	BAGUE	HÜLSE	CASQUILLO	G13	2
800067545	VITE M6X50	SCREW M6X50	VIS M6X50	SCHRAUBE M6X50	TORNILLO M6X50	G09	15
800067548	SUPPORTO ELASTICO	SPRING BEARING	SUPPORT ELASTIQUE	ELASTISCHES LAGERUNGSELEMENT	SOPORTE ELASTICO	F06	18
800067997	VITE M5X12	SCREW M5X12	VIS M5X12	SCHRAUBE M5X12	TORNILLO M5X12	G11	44
						G15	13
800069156	ROSETTA	WASHER	RONDELLE	UNTERLEGSCHEIBE	ARANDELA	G04	22
800069413	ANELLO DI TENUTA	GROMMET	BAGUE D'ETANCHEITE	DICHTUNGSRING	RETEN	G08	48
800069769	TAPPO CONICO	CONE-SHAPED PLUG	BOUCHON CONIQUE	KONISCHE GEWINDESCHRAUBE	TAPON CONOCO	G01	36
						G04	2
800070163	ROSETTA	WASHER	RONDELLE	UNTERLEGSCHEIBE	ARANDELA	B08	9
800070700	FASCETTA A MOLLA	SPRING CLAMP	COLLIER A RESSORT	FEDERSCHELLE	CINTA ELASTICA	D02	23
800070864	INTERRUPTORE STOP	STOP SWITCH	CONTACTEUR FEU STOP	BREMSLICHTSCHALTER	INTERRUPTOR DE STOP	D03	28
800070865	VITE INTERRUPTORE	SWITCH SCREW	VIS CONTACTEUR	SCHRAUBE FÜR SCHALTER	TORNILLO INTERRUPTOR	D03	29
800071007	SALTARELLO PER ROCCHETTO	SPROCKET RATCHET	CLIQUET	SPERRNOCKE FÜR KLEINRAD	MARTINETE PARA CORONA	G11	23
800071008	PUNTALE PER SALTARELLO	RATCHET PUSH ROD	POUSSOIR DE CLIQUET	METALLSPITZE FÜR SPERRNOCKE	PUNTAL PARA MARTINETE	G11	24
800071009	MOLLA	SPRING	RESSORT	FEDER	MUELLE	G11	25
800071010	NOTTOLINO DI SCORRIMENTO	SLIDING PAWL	BAGUE DE COULISSEMENT	LAUFZAHN	TRINQUETE DE DESLIZAMIENTO	G11	26
800072826	MOLLA	SPRING	RESSORT	FEDER	MUELLE	G11	35
800073529	OBLO' ISPEZIONE LIVELLO OLIO	OIL SIGHT GLASS	HUBLOT DE CONTROLE	SCHAUGLAS ÖLSTANDKONTROLLE	VENTANILLA DE INSPECCION NIVEL DE ACEITE	G01	40
800073558	ANELLO DI TENUTA	GROMMET	BAGUE D'ETANCHEITE	DICHTUNGSRING	RETEN	B04	15
						B05	15
800077921	VITE SCARICO SERBATOIO	FUEL TANK DRAIN SCREW	VIS DE VIDANGE RESERVOIR	TANK-ABLASSSCHRAUBE	TORNILLO VACIADO TANQUE	E03	16
800078219	FLANGIA CORONA	GEAR FLANGE	FLASQUE	ZAHNKRANZFLANSCH	BRIDA CORONA	C01	27
800078221	VITE	SCREW	VIS	SCHRAUBE	TORNILLO	B01	29
800078224	PARASTRAPPI PER CORONA	GEAR SPRING DRIVE	FLECTEUR POUR COURONNE	REISSCHUTZ FÜR ZAHNKRANZ	ACOPLAMIENTO FLEXIBLE PARA CORONA	C01	30
800079673	LAMPADA	BULB	AMPOULE	LAMPE	LAMPARA	F03	13
800080689	FILTRO OLIO (ASPIRAZIONE)	OIL FILTER (INTAKE)	FILTRE A HUILE (ADMISSION)	ÖLFILTER (ANSAUGFILTER)	FILTRO ACEITE (ASPIRACION)	G06	25
800080691	GUARNIZIONE	GASKET	JOINT	DICHTUNG	EMPAQUE	G01	41
800080695	GUARNIZIONE	GASKET	JOINT	DICHTUNG	EMPAQUE	G06	26
800080701	ALBERO POMPA OLIO	OIL PUMP SHAFT	ARBRE DE POMPE A HUILE	ÖLPUMPENWELLE	EJE BOMBA DE ACEITE	G06	7
800081164	ANELLO DI TENUTA	GROMMET	BAGUE D'ETANCHEITE	DICHTUNGSRING	RETEN	B06	17
						B07	17
800081174	DADO	NUT	ECROU	MUTTER	TUERCA	B06	14
						B07	14
800081221	CAPPUCCIO CANDELA	SPARK PLUG CAP	CAPUCHON DE BOUGIE	KERZENSTECKER	CAPUCHON BUJIA	G15	14

INDICE CODICI / DENOMINAZIONI

CODEX / DESIGNATION INDEX • INDEX CODES / DÉNOMINATIONS

INHALTSVERZEICHNIS CODE • ÍNDICE CÓDIGOS / DENOMINACIONES

Code	Denominazione	Description	Désignation	Bezeichnung	Descripción	Table	N°
800081227	SEMIFLANGIA TUBO SCARICO	EXHAUST PIPE HALF FLANGE	DEMI-BRIDE TUYAU D'ÉCHAPPEMENT	FLANSCHHÄLFTE AUSPUFFROHR	SEMIBRIDA TUBO ESCAPE	G16	9
800081236	ANELLO TENUTA ROTANTE	GROMMET ON REVOLVING PART	JOINT D'ÉTANCHEITE TOURNANT	DREHENDER DICHTUNGSRING	RETEN RODANTE	G07	10
800081237	ANELLO TENUTA FISSA	GROMMET ON FIXED PART	JOINT D'ÉTANCHEITE FIXE	FESTER DICHTUNGSRING	RETEN FIJO	G07	22
800081239	DISTANZIALE	SPACER	ENTRETOISE	ABSTANDHALTER	DISTANCIADOR	G07	5
800081261	PERNO RINVIO DISTRIBUZIONE	TIMING TRANSMISSION PIN	AXE RENVOI DISTRIBUTION	VORGELEGEWELLE VENTILSTEUERUNG	PERNO REENVIO DISTRIBUCION	G05	2
800081263	GUARNIZIONE SCARICO	EXHAUST GASKET	JOINT D'ÉCHAPPEMENT	AUSPUFFDICHTUNG	EMPAQUE ESCAPE	G16	2
800081269	COLLETTORE ENTRATA ACQUA	WATER INLET MANIFOLD	COLLECTEUR ENTREE D'EAU	WASSERFÄNGER	COLECTOR ENTRADA AGUA	G08	60
800081276	PRIGIONIERO	STUD BOLT	GOUJON	STIFTSCHRAUBE	ESPARRAGO	G04	4
800081280	MANICOTTO POMPA/COLLETTORE	PUMP/MANIFOLD SLEEVE	MANCHON POMPE/COLLECTEUR	VERBINDUNGSSTUTZEN PUMPE/KOLLEKTOR	MANGUITO ACOPLAMIENTO BOMBA/COLECTOR	G08	59
800081283	TERMOSTATO	THERMOSTAT	THERMOSTAT	THERMOSTAT	TERMOSTATO	G08	49
800081304	ANELLO DI TENUTA	GROMMET	BAGUE D'ÉTANCHEITE	DICHTUNGSRING	RETEN	G13	13
800081315	SEMICUSCINETTO DI BIELLA (ROSSO)	BIG END HALF BEARING (RED)	DEMI-COUSSINET DE BIELLE (ROUGE)	PLEUEL- LAGERSCHALENHÄLFTE (ROT)	SEMICOJINETE DE BIELLA (ROJO)	G02	5
800081316	SEMICUSCINETTO DI BANCO (ROSSO)	CRANKSHAFT BEARING (RED)	HALF DEMI-COUSSINET DE PALIER (ROUGE)	KURBELWELLEN- LAGERSCHALENHÄLFTE (ROT)	SEMICOJINETE PRINCIPAL (ROJO)	G01	17
800081317	SEMICUSCINETTO DI BANCO (ROSSO)	CRANKSHAFT HALF BEARING (RED)	DEMI-COUSSINET DE PALIER (ROUGE)	KURBELWELLEN- LAGERSCHALENHÄLFTE (ROT)	SEMICOJINETE PRINCIPAL (ROJO)	G01	16
800081357	INGRANAGGIO POMPA OLIO	OIL PUMP GEAR	PIGNON DE POMPE A HUILE	ÖLPUMPENZAHNRAD	ENGRANAJE BOMBA DE ACEITE	G06	3
800081362	ROTORE ESTERNO POMPA OLIO	OIL PUMP OUTER ROTOR	ROTOR EXTERIEUR POMPE A HUILE	ÄUSSERER ÖLPUMPENROTOR	ROTOR ESTERNO BOMBA DE ACEITE	G06	9
800081363	ROTORE INTERNO POMPA OLIO	OIL PUMP INNER ROTOR	ROTOR INTERIEUR POMPE A HUILE	INNERER ÖLPUMPENROTOR	ROTOR INTERNO BOMBA DE ACEITE	G06	8
800081364	ROTORE ESTERNO POMPA OLIO	OIL PUMP OUTER ROTOR	ROTOR EXTERIEUR POMPE A HUILE	ÄUSSERER ÖLPUMPENROTOR	ROTOR ESTERNO BOMBA DE ACEITE	G06	4
800081365	ROTORE INTERNO POMPA OLIO	OIL PUMP INNER ROTOR	ROTOR INTERIEUR POMPE A HUILE	INNERER ÖLPUMPENROTOR	ROTOR INTERNO BOMBA DE ACEITE	G06	5
800081380	PERNO	PIN	AXE	WELLE	PERNO	G14	15
800081381	PIASTRINA	PLATE	PLAQUETTE	BLECH	PLACA	G14	16
800081388	MOTORINO AVVIAMENTO	STARTER	DEMARREUR	ANLASSERMOTOR	MOTOR DE ARRANQUE	G15	6
800081393	VITE FISSAGGIO SUPPORTO	SUPPORT CLAMP SCREW	VIS DE FIXATION SUPPORT	BEFESTIGUNGSSCHRAUBE HALTERUNG	TORNILLO FIJACION SOPORTE	G14	7
800081402	PERNO COMANDO FRIZIONE	CLUTCH CONTROL PIN	POUSSOIR DE DEBRAYAGE	KUPPLUNGSSZAPFEN	PERNO ACCIONAMIENTO EMBRAGUE	G09	11
800081409	RACCORDO FILTRO OLIO	OIL FILTER UNION	RACCORD FILTRE A HUILE	ANSCHLUSS ÖLFILTER	RACOR FILTRO ACEITE	G01	20
800081412	TAPPO DI CHIUSURA	PLUG	BOUCHON	VERSCHLUSS	TAPON	G01	15
800081413	PIASTRINA	PLATE	PLAQUETTE	BLECH	PLACA	G01	27
800081418	PRIGIONIERO	STUD BOLT	GOUJON	STIFTSCHRAUBE	ESPARRAGO	G01	28
800081419	PRIGIONIERO	STUD BOLT	GOUJON	STIFTSCHRAUBE E	SPARRAGO	G01	29
800081422	CUSCINETTO	BEARING	ROULEMENT	LAGER	COJINETE	G01	22
800081424	CUSCINETTO	BEARING	ROULEMENT	LAGER	COJINETE	G01	30
						J03	3
800081443	PIATTELLO DI CONTENIMENTO	HOLDING CAP	FLASQUE	RÜCKHALTEBLECH	CAZOLETA DE RETENCION	G06	10
800081445	SUPPORTO PARASTRAPPI	SPRING DRIVE SUPPORT	SUPPORT FLECTEUR	REISSCHUTZHALTERUNG	SOPORTE EMBRAGUE DE SEGURIDAD	G14	5
800081451	ROSETTA DI SICUREZZA	SAFETY WASHER	RONDELLE DE SURETE	SICHERUNGSSCHEIBE	ARANDELA DE SEGURIDAD	G09	2
						G10	33
						G17	34
800081453	ANELLO DI TENUTA	GROMMET	BAGUE D'ÉTANCHEITE	DICHTUNGSRING	RETEN	G14	11
800081461	FLANGIA ALTERNATORE	ALTERNATOR FLANGE	STATOR	LICHTMASCHINENFLANSCH	BRIDA ALTERNADOR	G14	10
800081478	CILINDRO COMANDO FRIZIONE	CLUTCH CONTROL CYLINDER	CYLINDRE RECEPTEUR DEBRAYAGE	KUPPLUNGSSZYLINDER	CILINDRO ACCIONAMIENTO EMBRAGUE	G09	13
800081508	PIATTO SPINGIDISCHI	DISK THRUST PLATE	PLATEAU DE PRESSION	DRUCKTELLER	PLATO DE PRESION	G09	6

INDICE CODICI / DENOMINAZIONI

 CODEX / DESIGNATION INDEX • INDEX CODES / DÉNOMINATIONS
 INHALTSVERZEICHNIS CODE • ÍNDICE CÓDIGOS / DENOMINACIONES

Code	Denominazione	Description	Désignation	Bezeichnung	Descripción	Table	N°
800081510	DISCO CONDOTTO LISCIO	PLAIN DRIVEN PLATE	DISQUE LISSE GLATTE	GEFÜHRTE SCHEIBE	DISCO CONDUCTIDO LISO	G09	5
800081511	DISCO FRIZIONE GUARNITO	LINED CLUTCH DISK	DISQUE GARNI	KUPPLUNGSSCHEIBE MIT BELAG	DISCO EMBRAGUE CON JUNTA	G09	4
800081516	MOLLA	SPRING	RESSORT	FEDER	MUELLE	G09	8
800081517	ROSETTA	WASHER	RONDELLE	UNTERLEGSSCHEIBE	ARANDELA	G09	18
800081519	BUSSOLA	BUSH	BAGUE	HÜLSE	BUJE	G09	9
800081535	BOCCOLA	BUSH	DOUILLE	BUCHSE	BUJE	G03	7
800081536	VITE M6X1	SCREW M6X1	VIS M6X1	SCHRAUBE M6X1	TORNILLO M6X1	G03	5
						G07	14
800081538	GIRANTE	ROTOR	ROTOR	PUMPENRAD	RODETE	G07	7
800081539	ALBERO GIRANTE	ROTOR SHAFT	ARBRE DU ROTOR	PUMPENRADWELLE EJE	RODETE	G07	9
800081547	DADO FISSAGGIO TESTA	HEAD STOP NUT	ECROU DE FIXATION	MUTTER	TUERCA FIJACION CULATA		
			CULASSE	ZYLINDERKOPFBEFESTIGUNG		G04	21
800081552	PATTINO FISSO	FIXED GUIDE SHOE	PATIN FIXE	FESTE KETTENFÜHRUNG	PATIN FIJO	G05	10
800081565	INGRANAGGIO 5°	5th GEAR	PIGNON 5°	ZAHNRAD 5. GANG	ENGRANAJE 5°	G10	6
800081566	BUSSOLA	BUSH	BAGUE	HÜLSE	BUJE	G10	5
						G10	17
800081573	INGRANAGGIO 2°	2nd GEAR	PIGNON 2°	ZAHNRAD 2. GANG	ENGRANAJE 2°	G10	18
800081575	INGRANAGGIO 3°	3rd GEAR	PIGNON 3°	ZAHNRAD 3. GANG	ENGRANAJE 3°	G10	24
800081576	INGRANAGGIO 4°	4th GEAR	PIGNON 4°	ZAHNRAD 4. GANG	ENGRANAJE 4°	G10	25
800081577	BOCCOLA	BUSH	BAGUE	BUCHSE	BUJE	G10	23
800081578	ROSETTA	WASHER	RONDELLE	UNTERLEGSSCHEIBE	ARANDELA	G10	22
800081579	INGRANAGGIO 5°	5th GEAR	PIGNON 5°	ZAHNRAD 5. GANG	ENGRANAJE 5°	G10	26
800081580	INGRANAGGIO 1°	1st GEAR	PIGNON 1°	ZAHNRAD 1. GANG	ENGRANAJE 1°	G10	29
800081583	FORCELLA INNESTO MARCE	SHIFTING FORK	FOURCHETTE DE SELECTION	SCHALTGABEL	HORQUILLA ENGRANE MARCHA	G11	16
800081584	FORCELLA INNESTO MARCE	SHIFTING FORK	FOURCHETTE DE SELECTION	SCHALTGABEL	HORQUILLA ENGRANE MARCHA	G11	17
800081585	PERNO PER FORCELLA	FORK PIN	AXE DE FOURCHETTE	SCHALTGABELWELLE	PERNO PARA HORQUILLA	G11	18
800081590	PIASTRINA	PLATE	PLAQUETTE	BLECH	PLACA	G11	27
800081628	VITE AUTOFILETTANTE 2,9X6,5	TAPPING SCREW 2,9X6,5	VIS TARAUD 2,9X6,5	BLECHSCHRAUBE 2,9X6,5	TORNILLO AUTOENROSCANTE 2,9X6,5	A02	6
						A03	6
800082695	PERNO	PIN	AXE	ZAPFEN	PERNO	D03	39
						D04	34
800082708	VITE PIEDINO FORCELLA	FORK FOOT SCREW	VIS PIED DE FOURCHE	SCHRAUBE GABELFUSS	TORNILLO PATA HORQUILLA	B03	3
						B06	3
						B07	3
800082728	TAPPO	PLUG	BOUCHON	VERSCHLUSS	TAPON	D03	32
800082733	SERBATOIO OLIO FRENO ANTERIORE	FRONT BRAKE FLUID SUPPLY TANK	RESERVOIR DE LIQUIDE FREIN AVANT	BREMFLÜSSIGKEITSBEHÄLTER VORDERRADBREMSE	DEPOSITO ACEITE FRENO DELANTERO	D03	31
800082743	PERNO RITENUTA PASTIGLIE	PAD STOP PIN	AXE DE MAINTIEN DES PLAQUETTES	RÜCKHALTEBOLZEN BREMSBELÄGE	PERNO RETENCION PASTILLAS	C01	23
						C02	12
800082746	MOLLA RITEGNO PASTIGLIE	PAD CHECK SPRING	PLAQUETTE D'APPUI	RÜCKHALTEFEDER BREMSBELÄGE	MUELLE RETENCION PASTILLAS	C01	22
800082748	COPPIA PASTIGLIE FRENO POSTERIORE	REAR BRAKE PADS	PAIRE DE PLAQUETTES FREIN ARRIÈRE	BREMSBELAGPAAR HINTERRADBREMSE	PAR DE PASTILLAS DE FRENO	C01	21
800082750	GHIERA PERNO RUOTA ANTERIORE	FRONT WHEEL PIN RING NUT	ECROU AXE DE ROUE AVANT	NUTMUTER VORDERRADACHSE	VIROLA PERNO RUEDA DELANTERA	C02	8
800082752	PERNO RUOTA ANTERIORE	FRONT WHEEL PIN	AXE DE ROUE AVANT	VORDERRADACHSE	PERNO RUEDA DELANTERA	C02	7
800082753	PINZA FRENO POSTERIORE	REAR BRAKE CALIPER	ETRIER FREIN ARRIÈRE	BREMSSATTEL HINTERRADBREMSE	PINZA FRENO TRASERO	C01	20
800082758	DISCO FRENO ANTERIORE	FRONT BRAKE DISK	DISQUE FREIN AVANT	BREMSSSCHEIBE VORDERRADBREMSE	DISCO FRENO DELANTERO	C02	5
800082759	DISCO FRENO ANTERIORE	FRONT BRAKE DISK	DISQUE FREIN AVANT	BREMSSSCHEIBE VORDERRADBREMSE	DISCO FRENO DELANTERO	C02	5

**INDICE CODICI / DENOMINAZIONI**

CODEX / DESIGNATION INDEX • INDEX CODES / DÉNOMINATIONS

INHALTSVERZEICHNIS CODE • ÍNDICE CÓDIGOS / DENOMINACIONES

Code	Denominazione	Description	Désignation	Bezeichnung	Descripción	Table	N°
800082760	DISCO FRENO POSTERIORE	REAR BRAKE DISK	DISQUE FREIN ARRIÈRE	BREMSSCHEIBE HINTERRADBREMSE	DISCO FRENO TRASERO	C01	11
800082769	TERMINALE SX	LH END	TETE G.	LINKES ANSCHLUSSTEIL	TERMINAL IZQUIERDO	B08	2
800082775	BUSSOLA	BUSH	BAGUE	HÜLSE	CASQUILLO	B08	7
800082776	ANTIVIBRANTE	VIBRATION-DAMPER	ANTI-VIBRATIONS	SCHWINGUNGSDÄMPFER	ANTIVIBRANTE	B08	5
800084182	PASTIGLIA REGOLAZIONE GIOCO (SP.1.60)	CLEARANCE ADJUSTING PAD (THICKNESS 1.60)	PASTILLE DE CALAGE (SP.1.60)	EINSTELLPLÄTTCHEN VENTILSPIEL (STÄRKE 1.60)	PASTILLA REGULACION JUEGO (SP.1.60)	G05	21
800084858	DISTANZIALE	SPACER	ENTRETOISE	ABSTANDHALTER	DISTANCIADOR	B02	13
800084859	BUSSOLA SX FORCELLONE	FORK LH BUSH	DOUILLE G. BRAS OSCILLANT	LINKE SCHWINGENBUCHSE	CASQUILLO IZQUIERDA HORQUILLA	B01	7
800084863	VITE PER BILANCIERE	EQUALIZER SCREW	VIS DE BALANCIER	SCHRAUBE FÜR HINTERRADSWINGE	TORNILLO PARA BALANCIN	B02	15
800084865	VITE INF. FISSAGGIO MOTORE	ENGINE LOWER CLAMP SCREW	VIS INF. ANCRAGE MOTEUR	UNTERE MOTOR- BEFESTIGUNGSSCHRAUBE	TORNILLO INFERIOR FIJACION MOTOR	A01	15
800084866	VITE SUP. FISSAGGIO MOTORE	ENGINE UPPER CLAMP SCREW	VIS SUP. ANCRAGE MOTEUR	OBERE MOTOR- BEFESTIGUNGSSCHRAUBE	TORNILLO SUPERIOR FIJACION MOTOR	A01	14
800084867	VITE M12X30	SCREW M12X30	VIS M12X30	SCHRAUBE M12X30	TORNILLO M12X30	A01	17
800084868	VITE INF. BIELLA SOSPENSIONE	SUSPENSION SUPPORT LOWER SCREW	VIS INF. BIELLETTE DE SUSPENSION	UNTERE SCHRAUBE AUFHÄNGUNGS-SCHUBSTANGE	TORNILLO INF. BIELLA SUSPENSION	B02	6
800084869	VITE ANT. FISSAGGIO MOTORE	ENGINE FRONT CLAMP SCREW	VIS AV. ANCRAGE MOTEUR	VORDERE MOTOR- BEFESTIGUNGSSCHRAUBE	TORNILLO DELANTERO FIJACION MOTOR	A01	6
800084871	PIASTRINA	PLATE	PLAQUETTE	BLECH	PLACA	A01	5
800084872	DISTANZIALE	SPACER	ENTRETOISE	ABSTANDHALTER	DISTANCIADOR	B01	2
800084873	BUSSOLA DX FORCELLONE	FORK RH BUSH	BAGUE D. BRAS OSCILLANT	RECHTE SCHWINGENBUCHSE	CASQUILLO DER. HORQUILLA	B01	9
800084874	BUSSOLA	BUSH	BAGUE	HÜLSE	CASQUILLO	B02	5
800084875	REGISTRO	REGISTER	ECROU DE REGLAGE	EINSTELLVORRICHTUNG	REGULADOR	B02	3
800084882	TELAIO	CHASSIS	CADRE	RAHMEN	BASTIDOR	A01	1
800084889	VITE DISCO FRENO POSTERIORE	REAR BRAKE DISK SCREW	VIS DISQUE FREIN ARRIÈRE	SCHRAUBE BREMSSCHEIBE HINTERRADBREMSE	TORNILLO DISCO FRENO TRASERO	C01	12
800084890	FLANGIA DISCO FRENO POSTERIORE	REAR BRAKE DISK FLANGE	FLASQUE DISQUE FREIN ARRIÈRE	BREMSSCHEIBENFLANSCH HINTERRADBREMSE	BRIDA DISCO FRENO TRASERO	C01	9
800084891	DADO M7	NUT M7	ECROU M7	MUTTER M7	TUERCA M7	C01	13
800084893	ROSETTA	WASHER	RONDELLE	UNTERLEGSCHNEIBE	ARANDELA	C01	16
800084894	ROSETTA	WASHER	RONDELLE	UNTERLEGSCHNEIBE	ARANDELA	C01	32
800084898	FERMAGLIO	CLIP	JONC	KLEMMRING	BROCHE	C01	19
800084899	FERMAGLIO	CLIP	JONC	KLEMMRING	BROCHE	C01	34
800084902	VITE PER SPINA	PIN SCREW	VIS	SCHRAUBE FÜR STIFT	TORNILLO PARA PERNO	C01	10
800084903	DADO DX RUOTA POST.	REAR WHEEL RH NUT	ECROU D. ROUE ARRIERE	RECHTE MUTTER HINTERRAD	TUERCA DER. RUEDA TRASERA	C01	33
800084904	DADO SX RUOTA POST.	REAR WHEEL LH NUT	ECROU G. ROUE ARRIERE	LINKE MUTTER HINTERRAD	TUERCA IZQ. RUEDA TRASERA	C01	18
800084909	ANELLO DI TENUTA	GROMMET	BAGUE D'ETANCHEITE	DICHTUNGSRING	RETEN	C01	5
800084913	ANELLO ELASTICO	SNAP RING	CIRCLIP	SPRENGRING	ARO	C01	17
800084915	VITE DI FASATURA	TIMING SCREW	VIS DE CALAGE	SCHRAUBE PHASENAUSRICHTUNG	TORNILLO PARA FASE	A01	26
800084917	RADIATORE ACQUA SUPERIORE	UPPER WATER COOLER	RADIATEUR D'EAU SUPERIEUR	OBERER KÜHLER	RADIADOR AGUA SUPERIOR	G08	1
800084918	RADIATORE ACQUA INFERIORE	LOWER WATER COOLER	RADIATEUR D'EAU INFERIEUR	UNTERER KÜHLER	RADIADOR AGUA INFERIOR	G08	10
800084919	ELETTOVENTOLA INFERIORE	LOWER HEATER FAN	ELECTROVENTILATEUR INFERIEUR	UNTERES KÜHLGEBLÄSE	ELECTROVENTILADOR INFERIOR	G08	14
800084924	CORONA	GEAR	COURONNE	ZAHNKRANZ	CORONA	C01	28
800084934	SUPPORTO ELETTOVENTOLA	HEATER FAN SUPPORT	SUPPORT D'ELECTROVENTILATEUR	KÜHLGEBLÄSEHALTERUNG	SOPORTE ELECTROVENTILADOR	G08	15
800084936	CUSCINETTO	BEARING	ROULEMENT	LAGER	COJINETE	B01	5
800084937	ANELLO DI TENUTA	GROMMET	BAGUE D'ETANCHEITE	DICHTUNGSRING	RETEN	B01	6
800084938	CUSCINETTO	BEARING	ROULEMENT	LAGER	COJINETE	B01	3
800084939	ANELLO ELASTICO	SNAP RING	CIRCLIP	SPRENGRING	ARO	B01	4

INDICE CODICI / DENOMINAZIONI

 CODEX / DESIGNATION INDEX • INDEX CODES / DÉNOMINATIONS
 INHALTSVERZEICHNIS CODE • ÍNDICE CÓDIGOS / DENOMINACIONES

Code	Denominazione	Description	Désignation	Bezeichnung	Descripción	Table	N°
800084945	CUSCINETTO	BEARING	ROULEMENT	LAGER	COJINETE	B02	11
800084946	ANELLO DI TENUTA	GROMMET	BAGUE D'ETANCHEITE	DICHTUNGSRING	RETEN	B02	12
800084952	DADO M10	NUT M10	ECROU M10	MUTTER M10	TUERCA M10	C01	29
800085068	VITE FISSAGGIO BIELLA	CONNECTING ROD CLAMP SCREW	VIS DE FIXATION	BIELLE PLEUEL BEFESTIGUNGSSCHRAUBE	TORNILLO FIJACION BIELLA	G02	4
800085071	VITE M6X35	SCREW M6X35	VIS M6X35	SCHRAUBE M6X35	TORNILLO M6X35	G04	6
800085493	BUSSOLA	BUSH	BAGUE	HÜLSE	CASQUILLO	G11	32
800085495	SALTARELLO FISSA MARCE	GEARS STOP RATCHET	DOIGT DE VERROUILLAGE	SPERRNOCKE GANGWAHL	TRIQUETE FIJACION MARCHAS	G11	29
800086107	ROSETTA	WASHER	RONDELLE	UNTERLEGSCHEIBE	ARANDELA	G11	31
800086114	PIASTRA	PLATE	PLAQUE	PLATTE	PLACA	G11	5
800086116	CUSCINETTO	BEARING	ROULEMENT	LAGER	COJINETE	G11	4
800086117	GUARNIZIONE	GASKET	JOINT	DICHTUNG	EMPAQUE	G11	2
800086119	BOCCOLA DI RIFERIMENTO	DOWEL BUSH	PION DE CENTRAGE	ZENTRIERBUCHSE	BOCCOLA DI RIFERIMENTO	G01	14
						J03	2
800086121	CUSCINETTO	BEARING	ROULEMENT	LAGER	COJINETE	J03	4
800086131	BOCCOLA	BUSH	PION	BUCHSE	BUJE	G11	47
800086132	VALVOLA REGOLAZ. PRESSIONE	PRESSURE ADJUSTING VALVE	SOUPAPE REGULATRICE DE PRESSION	VENTIL DRUCKEINSTELLUNG	VALVULA REGULACION PRESION	G06	23
800086201	POMPA OLIO COMPLETA	OIL PUMP ASSEMBLY	POMPE A HUILE COMPLETE	ÖLPUMPE KOMPLETT	BOMBA DE ACEITE COMPLETA	G06	1
800086208	BUSSOLA	BUSH	BAGUE	HÜLSE	CASQUILLO	G14	2
800086223	ANELLO DI TENUTA	GROMMET	BAGUE D'ETANCHEITE	DICHTUNGSRING	RETEN	G15	2
800086395	VITE M15X22	SCREW M15X22	VIS M15X22	SCHRAUBE M15X22	TORNILLO M15X22	B01	32
800086396	ROSETTA	WASHER	RONDELLE	UNTERLEGSCHEIBE	ARANDELA	B01	31
800086406	AMMORTIZZATORE DI STERZO	STEERING DAMPER	AMORTISSEUR DE DIRECTION	LENKUNGSDÄMPFER	AMORTIGUADOR DE DIRECCION	B08	1
800086407	LIMITATORE STERZATA	STEERING LIMITING DEVICE	LIMITEUR ANGLE DE BRAQUAGE	LENKBEGRENZER	LIMITADOR DE VIRAJE	B03	5
800086408	TERMINALE DX	RH END	TETE D.	RECHTES ANSCHLUSSTEIL	TERMINAL DERECHO	B08	3
800086409	SUPPORTO	SUPPORT	SUPPORT	HALTERUNG	SOPORTE	B08	11
800086436	GHIERA	RING NUT	ECROU	GEWINDERING	VIROLA	B03	10
800086447	BUSSOLA	BUSH	BAGUE	HÜLSE	CASQUILLO	B02	14
800086459	CAPPUCCIO	CAP	CAPUCHON	KAPPE	CAPUCHON	F03	4
800086500	ANELLO DI TENUTA	GROMMET	BAGUE D'ETANCHEITE	DICHTUNGSRING	RETEN	B06	11
						B07	11
800086501	PARAPOLVERE	DUST COVER	JOINT-POUSSIÈRE	STAUBSCHUTZRING	GUARDAPOLVO	B06	9
						B07	9
800086503	BOCCOLA	BUSH	PION	BUCHSE	BUJE	B06	13
						B07	13
800086699	BUSSOLA	BUSH	BAGUE	HÜLSE	CASQUILLO	G10	3
800086702	ANELLO DI TENUTA	GROMMET	BAGUE D'ETANCHEITE	DICHTUNGSRING	RETEN	C01	15
						G07	13
800086726	RUOTA FONICA	PHONIC WHEEL	ROUE PHONIQUE	SENSOR RADDREHUNG	RUEDA FONICA	G02	7
800086727	DADO FISSAGGIO RUOTA FONICA	PHONIC WHEEL STOP NUT	ECROU ANCRAGE ROUE PHONIQUE	BEFESTIGUNGSMUTTER SENSOR RADDREHUNG	TUERCA FIJACION RUEDA FONICA	G02	6
800086728	COPERCHIO	COVER	COUVERCLE	DECKEL	TAPA	G01	46
800086732	FLANGIA RITEGNO RUOTA LIBERA	FREEWHEEL CHECK FLANGE	FLASQUE DE MAINTIEN ROUE LIBRE	RÜCKHALTEFLANSCH FREILAUF	BRIDA RETENCION RUEDA LIBRE	G14	18
800086735	PATTINO MOBILE	MOVABLE PAD	PATIN MOBILE	BEWEGLICHE KETTENFÜHRUNG	PATIN MOVIL	G05	13
800086737	ROSETTA	WASHER	RONDELLE	UNTERLEGSCHEIBE	ARANDELA	G01	23
800087124	INTERRUTTORE SPIA FOLLE	NEUTRAL PILOT LIGHT SWITCH	CONTACTEUR VOYANT POINT MORT	SCHALTER INTERRUPTOR LEERLAUFKONTROLLE	LUZ TESTIGO NEUTRO	G15	9
800087288	INGRANAGGIO RUOTA LIBERA	FREEWHEEL GEAR	PIGNON ROUE LIBRE	ZAHNRAD FREILAUF	ENGRANAJE RUEDA LIBRE	G14	3
800087289	RUOTA LIBERA	FREEWHEEL	ROUE LIBRE	FREILAUF	RUEDA LIBRE	G14	17
800087290	SUPPORTO PARASTRAPPI	SPRING DRIVE SUPPORT	SUPPORT DE FLECTEUR	HALTERUNG REISSSCHUTZ	SOPORTE ACOPLAMIENTO FLEXIBLE	G14	6
800087299	ROCCHETTO SELETORE	SELECTOR SPROCKET	ROCHET SELECTEUR	KLEINRAD GANGWAHL	CORONA SELECTOR	G11	22

INDICE CODICI / DENOMINAZIONI

CODEX / DESIGNATION INDEX • INDEX CODES / DÉNOMINATIONS

INHALTSVERZEICHNIS CODE • ÍNDICE CÓDIGOS / DENOMINACIONES

Code	Denominazione	Description	Désignation	Bezeichnung	Descripción	Table	N°
800087300	CUSCINETTO	BEARING	ROULEMENT	LAGER	COJINETE	G01	21
						J03	5
800087313	DISTANZIALE	SPACER	ENTRETOISE	ABSTANDHALTER	DISTANCIADOR	G09	19
800087441	SUPPORTO AMMORTIZZATORE	SHOCK ABSORBER SUPPORT	SUPPORT D'AMORTISSEUR	STOSSDÄMPFERBEFESTIGUNG	SOPORTE AMORTIGUADOR	B01	19
800087463	PIASTRINA	PLATE	PLAQUETTE	BLECH	PLACA	B01	12
800087465	PEDANA ANTERIORE SX	LH LOWER FOOTBOARD	CALE-PIED AVANT G.	VORDERE LINKE	ESTRIBO APOYAPIE		
				FUSSRASTE	DELANTERO IZQUIERDO	D01	7
800087466	PEDANA ANTERIORE DX	RH FRONT FOOTBOARD	CALE-PIED AVANT D.	VORDERE RECHTE	ESTRIBO APOYAPIE		
				FUSSRASTE	DELANTERO DERECHO	D02	7
800087467	TUBO OLIO FRENO ANTERIORE	FRONT BRAKE OIL PIPE	CANALISATION DE LIQUIDE FREIN AVANT	BREMSLEITUNG	TUBO ACEITE FRENO		
				VORDERRADBREMSE	DELANTERO	D03	21
800087468	TUBO OLIO FRIZIONE	CLUTCH OIL PIPE	CANALISATION DE LIQUIDE EMBRAYAGE	LEITUNG	TUBO ACEITE EMBRAGUE		
				KUPPLUNGSFLÜSSIGKEIT		D04	11
800087472	ANTIVIBRANTE	VIBRATION-DAMPER	ANTI-VIBRATIONS	SCHWINGUNGSDÄMPFER	ANTIVIBRANTE	A02	2
						A03	2
800087473	PATTINO SUPERIORE CATENA	CHAIN UPPER PAD	PATIN SUPERIEUR CHAINE	OBERE KETTENFÜHRUNG	PATIN SUPERIOR CADENA	B01	11
800087475	PATTINO INFERIORE CATENA	CHAIN LOWER PAD	PATIN INFERIEUR CHAINE	UNTERE KETTENFÜHRUNG	PATIN INFERIOR CADENA	B01	15
800087476	PATTINO CATENA	CHAIN PAD	PATIN CHAINE	KETTEN-FÜHRUNGSSCHUH	PATIN CADENA	A01	10
800087752	ANELLO DI TENUTA	GROMMET	BAGUE D'ETANCHEITE	DICHTUNGSRING	RETEN	G04	15
800087755	GUARNIZIONE	GASKET	JOINT	DICHTUNG	EMPAQUE	G04	18
800087756	GUARNIZIONE	GASKET	JOINT	DICHTUNG	EMPAQUE	G04	17
800087761	COPERCHIO TERMOSTATO	THERMOSTAT COVER	COUVERCLE DU THERMOSTAT	THERMOSTATDECKEL	TAPA TERMOSTATO	G08	50
800087771	GUARNIZIONE TESTA	HEAD GASKET	JOINT DE CULASSE	ZYLINDERKOPFDICHTUNG	JUNTA CULATA	G03	9
800087779	VITE FISSAGGIO COPERCHIO	COVER CLAMP SCREW	VIS DE FIXATION COUVERCLE	BEFESTIGUNGSSCHRAUBE	TORNILLO FIJACION TAPA		
				DECKEL		G04	19
800087781	ALBERO A CAMME (ASP.)	CAMSHAFT (INTAKE)	ARBRE A CAMES (ADM.)	NOCKENWELLE (EINLASS)	ARBOL DE LEVAS (ADM.)	G05	5
800087784	SUPPORTO PATTINO MOBILE	MOVABLE PAD SUPPORT	SUPPORT PATIN MOBILE	HALTERUNG BEWEGLICHE KETTENFÜHRUNG	SOPORTE PATIN MOVIL		
						G05	14
800087785	PERNO PATTINO MOBILE	PIN FOR MOVABLE PAD	AXE POUR PATIN MOBILE	ZAPFEN FÜR BEWEGLICHE KETTENFÜHRUNG	PERNO PARA PATIN MOVIL		
						G05	15
800087786	GUARNIZIONE	GASKET	JOINT	DICHTUNG	EMPAQUE	G01	49
800087792	GUARNIZIONE	GASKET	JOINT	DICHTUNG	EMPAQUE	G01	3
800088173	RELE' INTERMITTENZA	INTERMITTENCE RELAY	RELAIS CLIGNOTANTS	BLINKRELAIS	RELE' INTERMITENCIA	F04	2
800088342	ASTA COMANDO FRIZIONE	CLUTCH CONTROL ROD	TIGE DE DEBRAYAGE	KUPPLUNGSSTANGE	VARILLA ACCIONAMIENTO		
					EMBRAGUE	G09	12
800088343	RUOTA FONICA	PHONIC WHEEL	ROUE PHONIQUE	SENSOR RADDREHUNG	RUEDA FONICA	G17	36
800088344	PROTEZIONE	PROTECTION	PROTECTION	ABDECKUNG	PROTECCION	G11	43
800088346	SENSORE VELOCITÀ	SPEED SENSOR	CAPTEUR DE VITESSE	GESCHWINDIGKEITSSENSOR	SENSOR VELOCIDAD	G11	46
800088347	SPUGNA INSONORIZZANTE	SOUNDPROOFING SPONGE	MOUSSE INSONORISANTE	SCHALLDÄMPFERSCHWAMM	ESPONJA INSONORIZANTE	G11	42
800088415	ANELLO ELASTICO	SNAP RING	CIRCLIP	SPRENGRING	ANILLO ELASTICO	G10	7
800088416	INGRANAGGIO 6°	6th GEAR	PIGNON 6°	ZAHNRAD 6. GANG	ENGRANAJE 6°	G10	11
800088417	INGRANAGGIO 6°	6th GEAR	PIGNON 6°	ZAHNRAD 6. GANG	ENGRANAJE 6°	G10	21
800088418	CUSCINETTO	BEARING	ROULEMENT	LAGER	COJINETE	G09	17
800088515	CENTRALINA SICUREZZA	STARTER SAFETY	BOITIER DE SURETÉ DU	SICHERUNGSTEUERUNG	CENTRALITA DE SEGURIDAD		
	AVVIAMENTO	POWER UNIT	COMMANDE DEMARREUR	FÜR ANLASSER	DE ARRANQUE	F06	19
800088572	RELE'	RELAY	RELAIS	RELAIS	RELE'	F02	7
						F05	2
800088575	SENSORE TEMPERATURA OLIO	OIL TEMPERATURE SENSOR	CAPTEUR DE TEMPERATURE D'HUILE	SENSOR ÖLTEMPERATUR	SENSOR TEMPERATURA ACEITE	F05	1
						G15	18
800088585	FILTRO BENZINA	FUEL FILTER	FILTRE A ESSENCE	BENZINFILTER	FILTRO GASOLINA	G12	17
800089013	CHIAVE CANDELA	SPARK PLUG WRENCH	CLE A BOUGIE	KERZENSCHLÜSSEL	LLAVE PARA BUJIA	H01	7
800089274	ANELLO RITENUTA	RETAINING RING	JONC DE MAINTIEN	SCHLIESSRING	RETEN	B06	10
						B07	10
800089275	DISTANZIALE	SPACER	ENTRETOISE	ABSTANDHALTER	DISTANCIADOR	B06	12
						B07	12

INDICE CODICI / DENOMINAZIONI

 CODEX / DESIGNATION INDEX • INDEX CODES / DÉNOMINATIONS
 INHALTSVERZEICHNIS CODE • ÍNDICE CÓDIGOS / DENOMINACIONES

Code	Denominazione	Description	Désignation	Bezeichnung	Descripción	Table	N°
800089293	ANTIVIBRANTE	VIBRATION-DAMPER	ANTI-VIBRATIONS	SCHWINGUNGSDÄMPFER	ANTIVIBRANTE	E03	19
						E03	25
						F01	24
						F04	13
						F06	1
						G08	26
						G08	68
800089298	GOMMINO	RUBBER COVER	CAOUTCHOUC	GUMMI	GOMA	D01	18
						D02	18
800089299	BUSSOLA	BUSH	BAGUE	HÜLSE	CASQUILLO	G16	12
800089300	PIASTRINA	PLATE	PLAQUETTE	BLECH	PLACA	B01	13
800089302	ANTIVIBRANTE	VIBRATION-DAMPER	ANTI-VIBRATIONS	SCHWINGUNGSDÄMPFER	ANTIVIBRANTE	G16	1
800089303	VITE PER TERMINALE	END SCREW	VIS SCHRAUBE	FÜR ANSCHLUSSTEIL	TORNILLO PARA TERMINAL	B08	4
800089304	BUSSOLA	BUSH	BAGUE	HÜLSE	CASQUILLO	B08	6
800089305	VITE INTERRUPTORE ACCENSIONE	IGNITION LOCK SWITCH SCREW	VIS CONTACTEUR D'ALLUMAGE	SCHRAUBE ZÜNDSCHLOSS	TORNILLO INTERRUPTOR ENCENDIDO	A01	24
800089306	VITE BIELLA AMMORTIZZATORE STERZO	STEERING DAMPER SUPPORT SCREW	VIS BIELLETTE AMORTISSEUR DE DIRECTION	SCHRAUBE LENKUNGSDÄMPFER	TORNILLO BIELLA AMORTIGUADOR DIRECCION	B08	10
800089312	POMPA FRIZIONE	CLUTCH PUMP	MAITRE-CYLINDRE D'EMBRAYAGE	KUPPLUNGSPUMPE	BOMBA EMBRAGUE	D04	8
800089313	POMPA FRENO POSTERIORE	REAR BRAKE PUMP	MAITRE-CYLINDRE DE FREIN ARRIERE	BREMSPUMPE HINTERRADBREMSE	BOMBA FRENO TRASERO	D02	20
800089334	PROTEZIONE	PROTECTION	PROTECTION	VERKLEIDUNG	PROTECCION	D02	11
800089335	PROTEZIONE	PROTECTION	PROTECTION	VERKLEIDUNG	PROTECCION	D01	11
800089398	SENSORE PRESSIONE/ TEMPERATURA ARIA	AIR TEMPERATURE/ PRESSURE SENSOR	CAPTEUR PRESS./ TEMPERATURE AIR	SENSOR LUFTDRUCK/ TEMPERATUR	SENSOR PRESION / TEMPERATURA AIRE	F01	22
800089403	MANICOTTO ALIMENTAZIONE	FEED SLEEVE	MANCHON D'ALIMENTATION	MUFFE	MANGUITO ALIMENTACION	G13	20
800089404	FASCETTA A VITE	SCREW CLAMP	COLLIER A VIS	SCHRAUBENSHELLE	ABRAZADERA DE ROSCA	G13	22
800089405	RACCORDO ENTRATA POMPA ACQUA	WATER PUMP INLET UNION	RACCORD D'ENTREE POMPE A EAU	ANSCHLUSS EINLASS WASSERPUMPE	RACOR ENTRADA BOMBA AGUA	G07	18
800089406	ANELLO TENUTA	GROMMET	BAGUE D'ETANCHEITE	DICHTUNGSRING	RETEN	G11	39
800089410	ANELLO TENUTA	GROMMET	BAGUE D'ETANCHEITE	DICHTUNGSRING	RETEN	G11	7
800089412	COPERCHIO POMPA ACQUA	WATER PUMP COVER	COUVERCLE DE POMPE A EAU	WASSERPUMPENDECKEL	TAPA BOMBA AGUA	G07	12
800089422	PROTEZIONE	PROTECTION	PROTECTION	ABDECKUNG	PROTECCION	G01	50
800089424	ALBERO COMANDO SELETTORE	SELECTOR CONTROL SHAFT	ARBRE DE COMMANDE SELECTEUR	STEUERWELLE GANGWAHL	EJE MANDO SELECTOR	G11	33
800089425	TAPPO	PLUG	BOUCHON	VERSCHLUSS	TAPON	G01	18
800089426	ROSETTA	WASHER	RONDELLE	UNTERLEGSCHIEBE	ARANDELA	G01	19
800089427	POMPA ACQUA COMPLETA	WATER PUMP ASSEMBLY	POMPE A EAU COMPLETE	WASSERPUMPE KOMPLETT	BOMBA AGUA COMPLETA	G07	1
800089428	CORPO POMPA ACQUA COMPLETO	WATER PUMP CASING ASSEMBLY	CORPS DE POMPE A EAU COMPLET	WASSERPUMPENGEHÄUSE KOMPLETT	CUERPO BOMBA AGUA COMPLETA	G07	2
800089434	SCAMBIATORE OLIO	OIL COOLER	ECHANGEUR HUILE	ÖLTAUSCHER	CAMBIADOR DE ACEITE	G06	19
800089440	TUBO LUBRIFICAZIONE CAMBIO	CHANGE GEAR LUBRICATION PIPE	TUBE GRAISSAGE BOITE DE VITESSES	SCHMIERLEITUNG GETRIEBE	TUBO LUBRICACION CAMBIO	G01	26
800089445	RINVIO COMANDO DISTRIBUZIONE	TIMING CONTROL RENVOI TRANSMISSION	COMMANDE DE DISTRIBUTION	VORGELEGE VENTILSTEUERUNG	REENVIO MANDO DISTRIBUCION	G05	1
800089484	SPURGO	DRAIN SCREW	VIS DE PURGE	ENTLÜFTUNGSSCHRAUBE	ESPURGO	C01	24
						C02	13
800089491	PARAPOLVERE	DUST COVER	JOINT-POUSSIÈRE	STAUBSCHUTZRING	GUARDAPOLVO	C01	25
						C02	14
800089745	PIASTRINA	PLATE	PLAQUETTE	BLECH	PLACA	A01	2
800089747	PIASTRINA	PLATE	PLAQUETTE	BLECH	PLACA	A01	3
800089750	PERNO	PIN	AXE	ZAPFEN	PERNO	E01	22
800089751	ROSETTA	WASHER	RONDELLE	UNTERLEGSCHIEBE	ARANDELA	B01	36
						E01	23

INDICE CODICI / DENOMINAZIONI

CODEX / DESIGNATION INDEX • INDEX CODES / DÉNOMINATIONS

INHALTSVERZEICHNIS CODE • ÍNDICE CÓDIGOS / DENOMINACIONES

Code	Denominazione	Description	Désignation	Bezeichnung	Descripción	Table	N°
800089754	PIASTRINA	PLATE	PLAQUETTE	BLECH	PLACA	F04	12
800089757	DISTANZIALE	SPACER	ENTRETOISE	ABSTANDHALTER	DISTANCIADOR	B02	10
800089758	VITE FISSAGGIO SERBATOIO	FUEL TANK CLAMP SCREW	VIS DE FIXATION RESERVOIR	BEFESTIGUNGSSCHRAUBE	TORNILLO FIJACION	E03	27
800089759	LEVA COMANDO CAMBIO	GEAR LEVER	LEVIER DE SELECTION	SCHALTPEDALHEBEL	PALANCA ACCIONAMIENTO	D01	16
800089760	ECCENTRICO PER PEDALE	PEDAL ECCENTRIC	EXCENTRIQUE POUR PEDALE	EXZENTER FÜR HEBEL	EXCENTRICO PARA PEDAL	D01	17
						D02	17
800089770	SUPPORTO POMPA	PUMP SUPPORT	SUPPORT DE POMPE	BREMSPUMPENHALTERUNG	SOPORTE BOMBA	D02	30
800089771	SUPPORTO PEDANA ANTERIORE SX	LH FRONT FOOTBOARD SUPPORT	SUPPORT DE CALE-PIED AVANT GAUCHE	HALTERUNG VORDERE LINKE FUSSRASTE	SOPORTE ESTRIBO APOYAPIE DEL. IZQUIERDO	D01	1
800089772	SUPPORTO PEDANA ANTERIORE DX	RH FRONT FOOTBOARD SUPPORT	SUPPORT DE CALE-PIED AVANT DROITE	HALTERUNG VORDERE RECHTE FUSSRASTE	SOPORTE ESTRIBO APOYAPIE DEL. DERECHO	D02	1
800089773	BIELLA PER PEDANA SX	H FOOTBOARD SUPPORT	BIELLETTE DE CALE-PIED G.	STANGE LINKE FUSSRASTE	BIELA PARA APOYAPIE IZQ.	D01	2
800089774	BIELLA PER PEDANA DX	RH FOOTBOARD SUPPORT	BIELLETTE DE CALE-PIED D.	STANGE RECHTE FUSSRASTE	BIELA PARA APOYAPIE DER.	D02	2
800089777	PIASTRINA	PLATE	PLAQUETTE	BLECH	PLACA	D01	5
						D02	5
800089778	VITE PER ECCENTRICO	ECCENTRIC SCREW	VIS D'EXCENTRIQUE	SCHRAUBE FÜR EXZENTER	TORNILLO PARA EXCENTRICO	D01	6
						D02	6
800089782	CONTRAPPESO	COUNTERWEIGHT	CONTREPOIDS	GEGENGEWICHT	CONTRAPESO	D03	15
						D04	5
800089783	CONTRASTO BLOCCASTERZO	STEERING STOP	BUTEE DE VERROUILLAGE	DIRECTION AUFLAGE LENKERSCHLOSS	CONTRASTE BLOQUEADOR DE DIRECCION	B03	13
800089784	STAFFA DX SERBATOIO	FUEL TANK RH SUPPORT	PATTE D. RESERVOIR	RECHTE TANKBEFESTIGUNG	SOPORTE DER. DEPOSITO	E03	22
800089785	STAFFA SX SERBATOIO	FUEL TANK LH SUPPORT	PATTE G. RESERVOIR	LINKE TANKBEFESTIGUNG	SOPORTE IZQ. DEPOSITO	E03	23
800089786	VITE M6X21	SCREW M6X21	VIS M6X21	SCHRAUBE M6X21	TORNILLO M6X21	B01	14
						E02	27
						G08	25
800089787	BIELLETTA ROTAZIONE CODONE	TAIL HINGE	BIELLETTE ROTATION COQUE ARRIERE	DREHPLEUEL HECKTEIL	BIELA ROTACION COLA	E04	3
						E05	3
800089789	TUBO PER SCAMBIATORE	EXCHANGER PIPE	TUYAU POUR ECHANGEUR	LEITUNG FÜR WÄRMETAUSCHER	TUBO PARA CAMBIADOR	G08	64
800089791	TUBO MANDATA SCAMBIATORE	EXCHANGER DELIVERY PIPE	TUYAU REFOULEMENT ECHANGEUR	ZULEITUNG WÄRMETAUSCHER	TUBO ENVIO CAMBIADOR	G08	66
800089792	SEMIGUSCIO ANTERIORE TUBI	PIPE FRONT HALF BEARING	PLAQUETTE DE MAINTIEN CANALISATIONS	VORDERE LEITUNGS-KLAMMERHÄLFTE	SEMICASCO DELANTERO TUBOS	G08	70
800089799	CAPPUCCIO SX	LH CAP	CAPUCHON G.	LINKE KAPPE	CAPUCHON IZQUIERDO	G13	4
800089800	CAPPUCCIO DX	RH CAP	CAPUCHON D.	RECHTE KAPPE	CAPUCHON DERECHO	G13	5
800089801	PORTATUBO	PIPE CARRIER	PORTE-CANALISATION	LEITUNGSHALTERUNG	PORTATUBO	G13	1
800089802	SUPPORTO	SUPPORT	SUPPORT	HALTERUNG	SOPORTE	E04	1
						E05	1
800089965	CAVO MOTORINO AVVIAMENTO	STARTER CABLE	CABLE DU DEMARREUR	KABEL ANLASSERMOTOR	CABLE MOTOR DE ARRANQUE	F04	10
800089972	INTERRUTTORE MINIMA PRESSIONE OLIO	OIL MIN. PRESSURE SENSOR	MANOCONTACT PRESSION HUILE MIN.	ÖLDRUCKSCHALTER	INTERRUPTOR MINIMA PRESION ACEITE	G15	16
800090184	SENSORE RPM MOTORE	ENGINE RPM SENSOR	CAPTEUR COMPTE-TOURS	SENSOR MOTORDREHZAHL	SENSOR RPM MOTOR	G15	11
800090213	INTERRUTTORE PEDALE STOP	STOP PEDAL SWITCH	CONTACTEUR PEDALE DE STOP	BREMSLICHTSCHALTER BREMSPEDAL	INTERRUPTOR PEDAL STOP	F06	20
800090214	ETICHETTA	LABEL	ETIQUETTE	ETIKETT	ETIQUETA	F06	5
800090239	ANTIVIBRANTE	VIBRATION-DAMPER	ANTI-VIBRATIONS	SCHWINGUNGSDÄMPFER	ANTIVIBRANTE	F02	2
						F07	7
800090240	PIASTRINA	PLATE	PLAQUETTE	BLECH	PLACA	F02	13
800090241	SUPPORTO	SUPPORT	SUPPORT	HALTERUNG	SOPORTE	F02	3
800090242	VITE M7X60	SCREW M7X60	VIS M7X60	SCHRAUBE M7X60	TORNILLO M7X60	F03	21
800090243	MOLLA	SPRING	RESSORT	FEDER	MUELLE	E04	5
						E05	5

INDICE CODICI / DENOMINAZIONI

 CODEX / DESIGNATION INDEX • INDEX CODES / DÉNOMINATIONS
 INHALTSVERZEICHNIS CODE • ÍNDICE CÓDIGOS / DENOMINACIONES

Code	Denominazione	Description	Désignation	Bezeichnung	Descripción	Table	N°
800090244	TUBO CON RIDUZIONE	PIPE WITH ADAPTER	MANCHON DE REDUCTION	LEITUNG MIT REDUZIERSTÜCK	TUBO CON REDUCCION	G08	56
800090245	TUBO DI SPURGO	DRAIN PIPE	TUYAU DE PURGE	ENTLÜFTUNGSLEITUNG	TUBO DE ESPURGO	G08	32
800090249	FORNITURA SERRATURE	LOCKS KIT	FOURNITURE SERRURES	BAUSATZ SCHLÖSSER	SUMINISTRO CERRADURA	D05	1
800090250	DADO PER SERRATURA	LOCK NUT	ECROU POUR SERRURE	MUTTER FÜR SCHLOSS	TUERCA PARA CERRADURA	E04	6
						E05	6
800090251	TRASMISSIONE SERRATURA	LOCK TRANSMISSION	TRANSMISSION DE SERRURE	SEILZUG SCHLISSVORRICHTUNG	TRANSMISION CERRADURA	E04	7
800090265	SEMIGUSCIO INFERIORE	LOWER HALF BEARING	DEMI-COQUE INFERIEURE	UNTERE SCHALENHÄLFTE	SEMICASCO INFERIOR	D03	7
800090266	PIASTRINA	PLATE	PLAQUETTE	BLECH	PLACA	D03	9
800090271	TRASMISSIONE APERTURA GAS	THROTTLE OPENING TRANSMISSION	TRANSMISSION OUVERTURE DES GAZ	GASZUG ÖFFNUNG	TRANSMISION ABERTURA GAS	D03	12
800090272	TRASMISSIONE CHIUSURA GAS	THROTTLE CLOSING TRANSMISSION	TRANSMISSION FERMETURE DES GAZ	GASZUG SCHLIESSEN	TRANSMISION CIERRE GAS	D03	13
800090275	PEDALE FRENO POSTERIORE	REAR BRAKE PEDAL	PEDALE FREIN ARRIERE	BREMSPEDAL HINTERRADBREMSE	PEDAL FRENO TRASERO	D02	15
800090277	PEDALE CAMBIO	GEAR PEDAL	PEDALE DE SELECTION	SCHALTPEDAL	PEDAL CAMBIO	D01	15
800090279	CANNOTTO DI STERZO	STEERING TUBE	COLONNE DE DIRECTION	LENKROHR	TUBO DE LA DIRECCION	B03	8
800090280	GHIERA	RING NUT	ECROU	GEWINDERING	VIROLA	B03	11
800090282	TESTA DI STERZO	STEERING HEAD	TETE SUPERIEUR DIRECTION	LENKOPF CABEZA	TUBO DIRECCION	B03	12
800090284	BIELLETTA COMPLETA	SUPPORT ASSEMBLY	BIELLETTA COMPLETE	SCHUBSTANGE KOMPLETT	BIELA COMPLETA	B08	8
800090288	SPOILER PARAFANGO ANTERIORE	FRONT MUDGUARD SPOILER	SPOILER GARDE-BOUE AVANT	SPOILER VORDERER KOTFLÜGEL	SPOILER GUARDABARROS DELANTERO	E01	3
800090307	SUPPORTO FIANCHETTO DX	RH SIDE SUPPORT	SUPPORT DE CACHE D.	HALTERUNG RECHTES SEITENTEIL	SOPORTE LATERAL DERECHO	E03	18
800090312	PROTEZIONE	PROTECTION	PROTECTION	VERKLEIDUNG	PROTECCION	D02	31
800090313	TUBO OLIO FRENO POSTERIORE	REAR BRAKE OIL PIPE	CANALISATION DE LIQUIDE FREIN ARRIERE	BREMSLEITUNG HINTERRADBREMSE	TUBO ACEITE FRENO TRASERO	D02	34
800090314	SPINA ELASTICA	SPRING PIN	GOUPILLE FENDUE	SPANNSTIFT	PUA ELASTICA	D01	4
						D02	4
800090315	SERBATOIO OLIO FRENO POSTERIORE	REAR BRAKE FLUID SUPPLY TANK	RESERVOIR DE LIQUIDE FREIN ARRIERE	BREMSFLÜSSIGKEITSBEHÄLTER HINTERRADBREMSE	DEPOSITO ACEITE FRENO TRASERO	D02	21
800090316	DECAL	DECAL	ADHESIF	AUFKLEBER	CALCOMANIA	E01	9
						E04	14
						E05	18
800090317	DECAL	DECAL	ADHESIF	AUFKLEBER	CALCOMANIA	E01	25
800090318	DECAL	DECAL	ADHESIF	AUFKLEBER	CALCOMANIA	E01	18
800090319	DECAL	DECAL	ADHESIF	AUFKLEBER	CALCOMANIA	E01	19
						E01	26
800090320	DECAL	DECAL	ADHESIF	AUFKLEBER	CALCOMANIA	E04	13
						E05	17
800090321	DECAL	DECAL	ADHESIF	AUFKLEBER	CALCOMANIA	E02	17
800090322	DECAL	DECAL	ADHESIF	AUFKLEBER	CALCOMANIA	E03	7
800090344	PIASTRINA	PLATE	PLAQUETTE	BLECH	PLACA	E04	16
						E05	30
800090345	SUPPORTO	SUPPORT	SUPPORT	HALTERUNG	SOPORTE	E04	20
						E05	38
800090348	FILTRO ARIA	AIR FILTER	FILTRE A AIR	LUFTFILTER	FILTRO AIRE	E02	20
800090350	GUARNIZIONE	GASKET	JOINT	DICHTUNG	EMPAQUE	G13	14
800090355	CUSCINETTO	BEARING	ROULEMENT	LAGER	COJINETE	C02	2
800090356	DISTANZIALE	SPACER	ENTRETOISE	ABSTANDHALTER	DISTANCIADOR	C02	3
800090363	TAPPO	PLUG	CACHE	VERSCHLUSS	TAPON	F03	5
800090365	MASCHERA PROIETTORE	HEADLIGHT GRILLE	HABILLAGGE PROJECTEUR	SCHIEINWERFERMASKE	CUBRE PROYECTOR	F03	8
800090367	GUARNIZIONE	GASKET	JOINT	DICHTUNG	EMPAQUE	F03	17
800090368	MOLLETTA	SPRING	PINCE	KLAMMER	NUELE	F03	18
800090369	FANALE POSTERIORE COMPLETO	TAIL LAMP ASSEMBLY	FEU ARRIERE COMPLET	RÜCKLICHT KOMPLETT	PILOTO TRASERO COMPLETO	F07	1

**INDICE CODICI / DENOMINAZIONI**

CODEX / DESIGNATION INDEX • INDEX CODES / DÉNOMINATIONS

INHALTSVERZEICHNIS CODE • ÍNDICE CÓDIGOS / DENOMINACIONES

Code	Denominazione	Description	Désignation	Bezeichnung	Descripción	Table	N°
800090370	RETROVISORE DX CON INDICATORE	RH REARVIEW MIRROR WITH TURN INDICATOR	RETROVISEUR D. AVEC INDICATEUR	RECHTER RÜCKSPIEGEL MIT BLINKER	RETROVISOR DER. CON INDICADOR	F01	5
800090371	RETROVISORE SX CON INDICATORE	LH REARVIEW MIRROR WITH TURN INDICATOR	RETROVISEUR G. AVEC INDICATEUR	LINKER RÜCKSPIEGEL MIT BLINKER	RETROVISOR IZQ. CON INDICADOR	F01	14
800090372	INDICATORE DI DIREZIONE POSTERIORE DX	RH REAR TURN INDICATOR	FEU CLIGNOTANT ARRIERE D.	HINTERER RECHTER BLINKER	INDICADOR DE DIRECCION TRASERO DERECHO	F07	12
800090373	INDICATORE DI DIREZIONE POST.SX	LH REAR TURN INDICATOR	FEU CLIGNOTANT ARRIERE G.	HINTERER LINKER BLINKER	INDICADOR DE DIRECCION TRASERO IZQUIERDO	F07	17
800090374	CATADIOTTRO	RETROREFLECTOR	REFLECTEUR	KATZENAUGE	CATAFARO	A02 A03	21 23
800090375	INTERRUTTORE CAVALLETTO LATERALE	SIDE STAND SWITCH	CONTACTEUR BEQUILLE LATERALE	SCHALTER SEITENSTÄNDER	INTERRUPTOR CABALLETE LATERAL	F04	17
800090378	BIELLETTA SILENZIATORE	SILENCER SUPPORT	BIELLETTA SILENCIEUX	FEDERUNG SCHALLDÄMPFER	BIELA SILENCIADOR	G16	16
800090379	SELLA PILOTA	DRIVER'S SADDLE	SELLE PILOTE	FAHRERSITZ	SILLIN PILOTO	E04 E05	24 22
800090380	ANTIVIBRANTE	VIBRATION-DAMPER	ANTI-VIBRATIONS	SCHWINGUNGSDÄMPFER	ANTIVIBRANTE	E04 E05	25 23
800090381	TAMPONE POSTERIORE SELLA	SADDLE REAR PAD	TAMPON ARRIERE SELLE	HINTERER SITZBANKPUFFER	TAPON TRASERO SILLIN	E04	28
800090386	CRUSCOTTO COMPLETO	DASHBOARD ASSEMBLY	COMBINE DE BORD COMPLET	ARMATURENBRETT KOMPLETT	TABLERO COMPLETO	F02	9
800090390	SUPPORTO COMPONENTI ELETTRICI	ELECTRICAL PARTS SUPPORT	SUPPORT COMPOSANTS ELECTRIQUES	HALTERUNG ELEKTRISCHE BAUTEILE	SOPORTE COMPONENTES ELECTRICOS	F04	1
800090391	BUSSOLA	BUSH	BAGUE	HÜLSE	CASQUILLO	B01	16
800090392	BUSSOLA	BUSH	BAGUE	HÜLSE	CASQUILLO	A01 E02	11 26
800090394	SUPPORTO RELE'	RELAY SUPPORT	SUPPORT DE RELAIS	RELAISHALTERUNG	SOPORTE RELE'	F04	4
800090399	PIOLO SUPPORTO PINZA FRENO POSTERIORE	REAR BRAKE CALIPER SUPPORT PIN	PIN DE SUPPORT ETRIER DE FREIN ARRIERE	HALTERUNG BREMSSATTEL HINTERRADBREMSE BOLZEN	PERNO SOPORTE PINZA FRENO TRASERO	B01	9
800090401	DADO M8 CON RONDELLA	NUT M8 WITH WASHER	ECROU M8 AVEC RONDELLE	MUTTER M8 MIT UNTERLEGSCHLEIBE	TUERCA M8 CON ARANDELA	A02 A03	10 10
800090405	CABLAGGIO INDICATORE ANTERIORE SX	LH FRONT INDICATOR WIRES	CABLAGE CLIGNOTANT AVANT G.	KABEL VORDERER LINKER BLINKER	CABLEADO INDICADOR DELANTERO IZQUIERDO	F01	11
800090406	CABLAGGIO INDICATORE ANTERIORE DX	RH FRONT INDICATOR WIRES	CABLAGE CLIGNOTANT AVANT D.	KABEL VORDERER RECHTER BLINKER	CABLEADO INDICADOR DELANTERO DERECHO	F01	18
800090415	BUSSOLA	BUSH	BAGUE	HÜLSE	CASQUILLO	F07	6
800090416	PERNO PEDANA	FOOTBOARD PIN	AXE CALE-PIED	FUSSRASTENBOLZEN	PERNO ESTRIBO APOYAPIE'	D01	8
800090417	FASCETTA IN GOMMA	RUBBER CLAMP	COLLIER EN CAOUTCHOUC	GUMMISCHELLE	CINTA DE GOMA	A01 G08	7 55
800090418	MOLLA	SPRING	RESSORT	FEDER	MUELLE	D01 D02	10 10
800090419	FLANGIA	FLANGE	FLASQUE	FLANSCH	BRIDA	G16	32
800090427	RICETTACOLO	CLIP	LOGEMENT	SPANNKLEMME	RECEPTACULO	E01	10
800090429	ANELLO ELASTICO	SNAP RING	CIRCLIP	SPRENGRING	ANILLO DE MUELLE	A03 D01 D02	31 9 9
800090890	DADO ELASTICO	SPRING NUT	ECROU AUTOFREINE	ELASTISCHE MUTTER	TUERCA ELASTICA	D03 D04	16 6
800090891	PERNO	PIN	AXE	ZAPFEN	PERNO	D03 D04	24 18
800090892	ANELLO ELASTICO	NAP RING	CIRCLIP	SPRENGRING	ANILLO DE MUELLE	D03 D04	25 19
800090893	ANTIVIBRANTE	VIBRATION-DAMPER	ANTI-VIBRATIONS	SCHWINGUNGSDÄMPFER	ANTIVIBRANTE	E04 E05	21 40
800090894	ROSETTA	WASHER	RONDELLE	UNTERLEGSCHLEIBE	ARANDELA	D02	28
800090897	ANELLO PARAPOLVERE	DUST COVER RING	JOINT-POUSSIÈRE	STAUBSCHUTZRING	ANILLO GUARDAPOLVO	B03	9

INDICE CODICI / DENOMINAZIONI

 CODEX / DESIGNATION INDEX • INDEX CODES / DÉNOMINATIONS
 INHALTSVERZEICHNIS CODE • ÍNDICE CÓDIGOS / DENOMINACIONES

Code	Denominazione	Description	Désignation	Bezeichnung	Descripción	Table	N°
800090905	PERNO	PIN	AXE	ZAPFEN	PERNO	E04	18
						E05	32
800090906	GOMMINO ANTIFILAMENTO	RUBBER HOLDING ELEMENT	CAOUTCHOUC DE CALAGE	HALTEGUMMI	GOMA DE RETENCION	E04	19
						E05	33
800090907	DADO M6	NUT M6	ECROU M6	MUTTER M6	TUERCA M6	B08	14
800090909	VITE AUTOFILETTANTE	TAPPING SCREW	VIS TARAUD	BLECHSCHRAUBE	TORNILLO		
	2,9X9,5	2,9X9,5	2,9X9,5	2,9X9,5	AUTOENRROSCANTE 2,9X9,5	F01	17
800090910	BUSSOLA	BUSH	BAGUE	HÜLSE	CASQUILLO	F01	23
						F06	6
800090912	PROIETTORE ANTERIORE	HEADLIGHT	PROJECTEUR AVANT	SCHWEINWERFER	PROYECTOR DELANTERO	F02	1
800090913	ANTIVIBRANTE	VIBRATION-DAMPER	ANTI-VIBRATIONS	SCHWINGUNGSDÄMPFER	ANTIVIBRANTE	F06	15
800090915	PIASTRINA	PLATE	PLAQUETTE	LECH	PLACA	F03	19
800090919	GUARNIZIONE	GASKET	JOINT	DICHTUNG	EMPAQUE	G12	8
800090920	POMPA BENZINA	FUEL PUMP	POMPE A ESSENCE	BENZINPUMPE	BOMBA GASOLINA	G12	9
800090921	SUPPORTO ELASTICO	SPRING SUPPORT	SUPPORT SOUPLE	ELASTISCHES LAGERUNGSELEMENT	SOPORTE ELASTICO	G12	12
800090923	GUARNIZIONE	GASKET	JOINT	DICHTUNG	EMPAQUE	E03	15
800090925	TERMINALE DI INNESTO	COUPLER	RACCORD	VERBINDUNGSTEIL	TERMINAL DE ACOPLAMIENTO	G12	5
800090927	TAPPO	PLUG	BOUCHON	VERSCHLUSS	TAPON	G12	2
800090929	REGOLATORE DI PRESSIONE	PRESSURE REGULATOR	REGULATEUR DE PRESSION	DRUCKREGLER	REGULADOR DE PRESION	G12	18
800090930	ANELLO ELASTICO	SNAP RING	CIRCLIP	SPRENGRING	ANILLO ELASTICO	G12	21
800090939	ANELLO DI TENUTA	GROMMET	BAGUE D'ETANCHEITE	DICHTUNGSRING	RETEN	G12	6
800090940	TUBO IN GOMMA	HOSE	DURIT	GUMMISCHLAUCH	TUBO DE GOMA	E03	8
						K02	6
800090942	BUSSOLA	BUSH	BAGUE	HÜLSE	CASQUILLO	G16	13
800090943	BUSSOLA	BUSH	BAGUE	HÜLSE	CASQUILLO	A01	32
						G08	11
						G16	18
800090945	ANELLO DI TENUTA	GROMMET	BAGUE D'ETANCHEITE	DICHTUNGSRING	RETEN	G08	34
800090946	AVVISATORE ACUSTICO	WARNING HOOPER	AVERTISSEUR SONORE	HUPE	CLAXON	F02	5
800090948	PARAFANGO ANTERIORE	FRONT MUDGUARD	GARDE-BOUE AVANT	VORDERER KOTFLÜGEL	GUARDABARRO DELANTERO	E01	1
800090963	PORTATARGA	NUMBER PLATE HOLDER	SUPPORT DE PLAQUE	NUMMERNRISCHILDBEFESTIGUNG	PORTAPLACA	A02	15
						A03	17
800090964	FIANCHETTO DX AIRBOX	AIRBOX RH SIDE	CACHE D. AIRBOX	RECHTES AIRBOX-SEITENTEIL	LATERAL DER. AIRBOX	E02	10
800090965	FIANCHETTO SX AIRBOX	AIRBOX LH SIDE	CACHE G. AIRBOX	LINKES AIRBOX-SEITENTEIL	LATERAL IZQ. AIRBOX	E02	9
800090972	TAPPO	PLUG	BOUCHON	VERSCHLUSS	TAPON	G16	7
800090973	BIELLETTA PER SCARICO	EXHAUST SUPPORT	BIELLETTE D'ECHAPPEMENT	SCHWINGPLEUEL FÜR AUSPUFF	BIELA PARA ESCAPE	A01	30
800090974	PIASTRINA	PLATE	PLAQUETTE	BLECH	PLACA	G16	20
800090977	PIOLO AGGANCIAMENTO FIANCHETTO	SIDE HOOK PIN	PION FIXATION CACHE	HAKEN FÜR SEITENTEIL	ESPIGA ENGANCHE LATERAL	E03	24
800090978	TAMPONE	PAD	TAMPON	PUFFER	TAPON	E03	4
800090979	TAMPONE	PAD	TAMPON	PUFFER	TAPON	B01	23
						F07	5
						F07	23
800090981	SUPPORTO FIANCHETTO SX	LH SIDE SUPPORT	SUPPORT DE CACHE G.	HALTERUNG LINKES SEITENTEIL	SOPORTE LATERAL IZQ.	E03	21
800090985	TARGHETTA LOGO CRC	CRC LOGO PLATE	MONOGRAMME CRC	SCHILD MARKENZEICHEN CRC	LETRERO LOGO CRC	E02	7
800090986	TARGHETTA LOGO CRC	CRC LOGO PLATE	MONOGRAMME CRC	SCHILD MARKENZEICHEN CRC	LETRERO LOGOCRC	E02	4
800090988	GRAFFETTA	CLIP	PLAQUETTE	KLEMME	GRAPA	G08	38
800090998	PIASTRINA	PLATE	PLAQUETTE	BLECH	CHAPA	B01	17
800090999	PIASTRINA	PLATE	PLAQUETTE	BLECH	CHAPA	B01	18
800091001	SUPPORTO	SUPPORT	SUPPORT	HALTERUNG	SOPORTE	F02	8
800091005	GRAFFETTA	CLIP	AGRAPHÉ	KLAMMER	GRAPA	E01	4
800091008	DADO ELASTICO M6	SPRING NUT M6	ECROU AUTOFREINE M6	ELASTISCHE MUTTER M6	TUERCA ELASTICA M6	E02	21
800091011	VALVOLA	VALVE	VALVE	VENTIL	VALVULA	C01	3
						C02	4

INDICE CODICI / DENOMINAZIONI

CODEX / DESIGNATION INDEX • INDEX CODES / DÉNOMINATIONS

INHALTSVERZEICHNIS CODE • ÍNDICE CÓDIGOS / DENOMINACIONES

Code	Denominazione	Description	Désignation	Bezeichnung	Descripción	Table	N°
800091022	DADO ELASTICO M4	SPRING NUT M4	ECROU AUTOFREINE M4	ELASTISCHE MUTTER M4	TUERCA ELASTICA M4	B01	27
						E01	15
800091027	PROTEZIONE	PROTECTION	PROTECTION	ABDECKUNG	PROTECCION	B02	8
800091029	STAFFA FISSAGGIO RADIATORI	RADIATORS CLAMP	PATTE DE MAINTIEN RADIATEUR	KÜHLERBEFESTIGUNG	SOPORTE FIJACION RADIADOR	G08	27
800091031	TUBO COLLEGAMENTO RADIATORI	RADIATORS COUPLING PIPE	TUYAU RACCORDEMENT RADIATEURS	ANSCHLUSSLEITUNG KÜHLER	TUBO CONEXION RADIADOR	G08	20
800091033	DADO M4	NUT M4	ECROU M4	MUTTER M4	TUERCA M4	A02	22
						A02	24
						A03	24
						A03	26
800091037	TUBO IN GOMMA	HOSE	DURIT	GUMMISCHLAUCH	TUBO DE GOMA	G13	19
						K02	22
800091064	PRIGIONIERO	STUD BOLT	GOIJON	STIFTSCHRAUBE	ESPARRAGO	G04	4
800091114	CAVI TELERUTTORE BATTERIA	BATTERY ELECTROMAGNETIC SWITCH CABLES	CABLES TELERUPTEUR BATTERIE	KABEL BATTERIE- FERNRELAIS	CABLES TELERRUPTOR BATERIA	F04	8
800091115	TELERUTTORE AVVIAMENTO	SOLENOID STARTER	TELERUPTEUR DU DEMARREUR	ANLASSER FERNRELAIS	TELERRUPTOR DE ARRANQUE	F04	5
800091216	COPERCHIO	COVER	COUVERCLE	DECKEL	TAPA	F06	4
800091217	GRUPPO CAVI ANTERIORE	FRONT CABLES SET	FAISCEAU AVANT	VORDERER KABELBAUM	CABLEADO DELANTERO	F03	14
800091235	BOBINE DI ACCENSIONE	IGNITION COILS	BOBINE D'ALLUMAGE	ZÜNDSPULEN	BOBINA DE ENCENDIDO	F04	11
800091533	COMMUTATORE DX	RH SWITCH	COMODO D.	RECHTER WECHSELSCHALTER	CONMUTADOR DER.	D03	20
800091534	COMMUTATORE SX	LH SWITCH	COMODO G.	LINKER WECHSELSCHALTER	CONMUTADOR IZQUIERDO	D04	10
800091596	FLAUTO BENZINA	FUEL DUCT	CONDUIT ESSENCE	BENZINROHR	CONDUCTO DE ALIMENTACION	G13	16
800091597	ANELLO DI TENUTA	GROMMET	BAGUE D'ETANCHEITE	DICHTUNGSRING	RETEN	G15	7
800091603	ANELLO ELASTICO	SNAP RING	CIRCLIP	SPRENGRING	ANILLO ELASTICO	G11	8
800091630	RETINA	NET	GRILLE	GITTERNETZ	REDECILLA	E02	2
800091631	RETINA	NET	GRILLE	GITTERNETZ	REDECILLA	E02	6
800091633	ANTIVIBRANTE	VIBRATION-DAMPER	ANTI-VIBRATIONS	SCHWINGUNGSDÄMPFER	ANTIVIBRANTE	E03	26
800091642	TARGHETTA TESTA STERZO	STEERING HEAD PLATE	MONOGRAMME TE SUP.	SCHILD LENKKOPF	ETIQUETA CABEZA DE DIRECCION	B03	16
800091645	CHIAVE GHIERA CUSCINETTI STERZO	STEERING BEARING RING NUT WRENCH	CLE A GRIFFES ROULEMENTS DIR.	SCHLÜSSEL GEWINDERING LENKLAGER	LLAVE VIROLA COJINETE DIRECCION	J01	2
800091648	SUPPORTO BATTERIA	BATTERY SUPPORT	SUPPORT DE BATTERIE	BATTERIEHALTER	SOPORTE BATERIA	A02	11
						A03	11
800091653	PIASTRINA	PLATE	PLAQUETTE	BLECH	PLACA	F04	18
						F07	10
800091655	PERNO FORCELLONE	FORK PIN	AXE DE BRAS OSCILLANT	SCHWINGENZAPFEN	PERNO HORQUILLA	B01	30
800091667	CUPOLINO	DASHBOARD GUARD	TETE DE CARENAGE	SPORTSCHEIBE	PROTECCION	E01	8
800091668	FIANCATA CARENA DX	RH FAIRING SIDE	FLANC DE CARENAGE D.	RECHTES KAROSSERIE- SEITENTEIL	LATERAL CARENADO DERECHO	E01	17
800091669	FIANCATA CARENA SX	LH FAIRING SIDE	FLANC DE CARENAGE G.	LINKES KAROSSERIE- SEITENTEIL	LATERAL CARENADO IZQUIERDO	E01	24
800091670	CONDOTTO ASPIRAZIONE DX	RH INTAKE DUCT	CONDUIT D'ADMISSION D.	RECHTER ANSAUGSTUTZEN	CONDUCTO DE ASPIRACION DERECHO	E02	1
800091671	CONDOTTO ASPIRAZIONE SX	LH INTAKE DUCT	CONDUIT D'ADMISSION G.	LINKER ANSAUGSTUTZEN	CONDUCTO DE ASPIRACION IZQUIERDO	E02	5
800091672	CODONE	TAIL	COQUE ARRIERE	HECKTEIL	COLA	E04	12
800091673	SERBATOIO BENZINA	FUEL TANK	RESERVOIR D'ESSENCE	BENZINTANK	DEPOSITO GASOLINA	E03	6
800091674	AIRBOX	AIRBOX	AIRBOX	AIRBOX	AIRBOX	E02	16
800091680	PROTEZIONE SCARICO	EXHAUST PROTECTION	PROTECTION ECHAPPEMENT	AUSPUFFVERKLEIDUNG	PROTECCION ESCAPE	G16	22
800091682	CATENA	CHAIN	CHAINE	KETTE	CADENA	C01	35
800091684	POLIELLISSOIDALE ANABBAGLIANTE	POLYELLIPSOIDAL LOWER BEAM	POLYELLIPSOIDAL CODE	POLYELLIPSOID ABBLENDLICHT	MULTIELIPSOIDAL LUZ DE CARRETERA	F03	10
800091685	POLIELLISSOIDALE ABBAGLIANTE	POLYELLIPSOIDAL UPPER BEAM	POLYELLIPSOIDAL PHARE	POLYELLIPSOID FERNLICHT	MULTIELIPSOIDAL LUZ DE CRUCE	F03	9
800091688	TUBO SCARICO-SFIATO SERBATOIO	EXHAUST PIPE-FUEL TANK BREATHING PIPE	TUYAU VIDANGE-EVENT RESERVOIR	ABLASS- ENTLÜFTUNGS- LEITUNG BENZINTANK	TUBO DESCARGA RESPIRADERO TANQUE	E03	13

INDICE CODICI / DENOMINAZIONI

 CODEX / DESIGNATION INDEX • INDEX CODES / DÉNOMINATIONS
 INHALTSVERZEICHNIS CODE • ÍNDICE CÓDIGOS / DENOMINACIONES

Code	Denominazione	Description	Désignation	Bezeichnung	Descripción	Table	N°
800091689	RACCORDO A Y	WYE	RACCORD EN Y	ZWEIWEGEANSCHLUSS	RACOR A Y	E03	12
800091690	TUBO SCARICO SERBATOIO	FUEL TANK DRAIN PIPE	TUYAU DE VIDANGE RESERVOIR	TANK-ABLASSLEITUNG TUBO	DESCARGA TANQUE	E03	11
800091691	VITE PER RACCORDI IDRAULICI	HYDRAULIC UNION SCREW	VIS POUR RACCORDS HYDRAULIQUE	SCHRAUBE FÜR ANSCHLÜSSE HYDRAULIKLEITUNGEN	TORNILLO PARA CONEXION HIDRAULICA	D04	13
800091692	VITE PER RACCORDI IDRAULICI	HYDRAULIC UNION SCREW	VIS POUR RACCORDS HYDRAULIQUE	SCHRAUBE FÜR ANSCHLÜSSE HYDRAULIKLEITUNGEN	TORNILLO PARA CONEXION HIDRAULICA	D02 D03 D04	35 22 12
800091693	GUARNIZIONE	GASKET	JOINT	DICHTUNG	EMPAQUE	A01	28
800091695	TUBO SFIATO SERBATOIO	FUEL TANK BREATHER PIPE	TUYAU D'EVENT RESERVOIR	TANK-ENTLÜFTUNGSLEITUNG	TUBO RESPIRADERO TENQUE	E03	10
800091697	VITE M8X30	SCREW M8X30	VIS M8X30	SCHRAUBE M8X30	TORNILLO M8X30	G11	48
800091707	TAPPO	PLUG	BOUCHON	VERSCHLUSS	TAPON	G08	36
800091886	INGRANAGGIO INTERMEDIO	IDLER GEAR	PIGNON INTERMEDIAIRE	ZWISCHEN-ZAHNRAD	ENGRANAJE INTERMEDIO	G14	14
800091891	INGRANAGGIO 3°-4°	3rd-4th GEAR	PIGNON 3°-4°	ZAHNRAD 3. GANG-4. GANG	ENGRANAJE 3°-4°	G10	8
800091893	INGRANAGGIO 2°	2nd GEAR	PIGNON 2°	ZAHNRAD 2. GANG	ENGRANAJE 2°	G10	12
800091895	TENDICATENA	CHAIN TIGHTENER	TENDEUR DE CHAINE	KETTENSPELLER	TENSIONADOR DE CADENA	G05	17
800091897	ALBERO MOTORE COMPLETO	DRIVING SHAFT ASSEMBLY	VILEBREQUIN COMPLET	KURBELWELLE KOMPLETT	CIGÜEÑAL COMPLETO	G02	1
800091898	ALBERO MOTORE	DRIVING SHAFT	VILEBREQUIN	KURBELWELLE	CIGÜEÑAL	G02	2
800091899	BIELLA COMPLETA	CONNECTING ROD ASSEMBLY	BIELLE COMPLETE	PLEUEL KOMPLETT	BIELA COMPLETA	G02	3
800091901	ALBERO SECONDARIO	TRANSMISSION SHAFT	ARBRE SECONDAIRE	VORGELEGEWELLE	ARBOL SECUNDARIO	G17	17
800091914	UGELLO OLIO PISTONE	PISTON OIL NOZZLE	TUYERE D'HUILE DE PISTON	ÖLDÜSE FÜR KOLBEN	TUBO DEL ACEITE PARA PISTON	G06	29
800091915	ASSIEME UGELLI OLIO PISTONI	PISTON OIL NOZZLES ASSEMBLY	ENSEMBLE TUYERES D'HUILE DE PISTONS	BAUGRUPPE ÖLDÜSEN FÜR KOLBEN	CONJUNTOTUBOS DEL ACEITE PARA PISTONES	G06	28
800091924	DADO M22	NUT M22	ECROU M22	MUTTER M22	TUERCA M22	G09 G10 G17	3 34 35
800091926	MOZZO PORTADISCHI	DISK HUB	NOIX D'EMBRAYAGE	KUPPLUNGSSCHEIBENNABE	CUBO PORTADISCOS	G09	1
800091927	ALBERO PRIMARIO COMPLETO	MAIN SHAFT ASSEMBLY	ARBRE PRIMAIRE COMPLET	HAUPTANTRIEBSWELLE KOMPLETT	ARBOL PRIMARIO COMPLETO	G10	2
800092185	FANALE TARGA	NUMBER PLATE LIGHT	ECLAIREUR	NUMMERN-SCHILDBELEUCHTUNG	LUZ PLACA	F07	20
800092246	TUBO PER SCAMBIATORE	EXCHANGER PIPE	TUBE POUR ECHANGEUR	LEITUNG FÜR WÄRMETAUSCHER	TUBO PARA CAMBIADOR	G08	74
800092247	FASCETTA IN GOMMA	RUBBER CLAMP	COLLIER EN CAOUTCHOUC	GUMMISCHELLE	CINTA DE GOMA	D04 F02 F04 F05 F06 G08	36 14 22 3 8 30
800092248	FASCETTA IN GOMMA	RUBBER CLAMP	COLLIER EN CAOUTCHOUC	GUMMISCHELLE	CINTA DE GOMA	D04 E04 E05 F04 F05 F06 G08 G15	16 11 11 23 6 9 41 19
800092251	TUBO SFIATO VAPORI OLIO	OIL VAPORS BREATHER PIPE	TUYAU D'EVENT VAPEURS D'HUILE	ÖLDAMPF- ENTLÜFTUNGSLEITUNG	TUBO RESPIRADERO VAPORES DE ACEITE	E02	23
800092256	FASCETTA CLIC R	CLIC R CLAMP	COLLIER CLIC R	SHELLE CLIC R	ABRAZADERA	G08	31
800092257	TARGHETTA BATTERIA	BATTERY DATA PLATE	PLAQUETTE BATTERIE	BATTERIE-TYPENSCHILD	ETIQUETA BATERIA	A02 A03	3 3
800092261	TERMORIFLETTENTE	THERMOREFLECTOR	THERMOREFLECTEUR	HITZESCHUTZ	TERMOREVERBERANTE	E01	20
800092262	TERMORIFLETTENTE	THERMOREFLECTOR	THERMOREFLECTEUR	HITZESCHUTZ	TERMOREVERBERANTE	E01	21
800092263	TERMORIFLETTENTE	THERMOREFLECTOR	THERMOREFLECTEUR	HITZESCHUTZ	TERMOREVERBERANTE	E01	27
800092264	TERMORIFLETTENTE	THERMOREFLECTOR	THERMOREFLECTEUR	HITZESCHUTZ	TERMOREVERBERANTE	E01	28
800092265	TERMORIFLETTENTE	THERMOREFLECTOR	THERMOREFLECTEUR	HITZESCHUTZ	TERMOREVERBERANTE	E01	31

INDICE CODICI / DENOMINAZIONI

 CODEX / DESIGNATION INDEX • INDEX CODES / DÉNOMINATIONS
 INHALTSVERZEICHNIS CODE • ÍNDICE CÓDIGOS / DENOMINACIONES

Code	Denominazione	Description	Désignation	Bezeichnung	Descripción	Table	N°
800092266	TERMORIFLETTENTE	THERMOREFLECTOR	THERMOREFLECTEUR	HITZESCHUTZ	TERMOREVERBERANTE	E01	30
800092270	DADO FISSAGGIO	FUEL TANK LOWER	ECROU DE FIXATION	UNTERE BEFESTIGUNGSMUTTER	TUERCA FIJACION	E03	28
	INFERIORE SERBATOIO	STOP NUT	INFERIEUR DE RESERVOIR	BENZINTANK	INFERIOR TANQUE		
800092272	SOTTOCARENA	UNDERFAIRING	SABOT DE CARENAGE	KAROSSERIE-UNTERTEIL	CARENADO INFERIOR	E01	29
800092433	SEMICONO PER VALVOLA	COTTERS	DEMI-CLAVETTE DE SOUPAPE	HALBKEGEL FÜR VENTIL	SEMICONO PARA VALVULA	G04	14
800092447	COPERCHIO TESTA	HEAD COVER	COUVRE-CULASSE	ZYLINDERKOPFDECKEL	TAPA CULATA	G04	16
800092449	COLLETTORE ALIMENTAZIONE	INDUCTION MANIFOLD	COLLECTEUR ALIMENTATION	VERSORGUNGSSTUTZEN	COLECTOR ALIMENTACION	G13	17
800092456	BICCHIERINO PER VALVOLA	VALVE CUP	GODET POUR SOUPAPE	VENTILBECHER	TAZA PARA VALVULA	G05	20
800092465	COPERCHIO	COVER	COUVERCLE	DECKEL	TAPA	G01	2
800092467	COPERCHIO	COVER	COUVERCLE	DECKEL	TAPA	G01	39
800092469	COPPA OLIO	OIL PAN	CARTER D'HUILE	ÖLWANNE	CARTER ACEITE	G01	48
800092470	SUPPORTO	SUPPORT	SUPPORT	HALTERUNG	SOPORTE	G01	31
800092473	TAPPO	PLUG	BOUCHON	VERSCHLUSS	TAPON	G01	44
800092478	ROSETTA	WASHER	RONDELLE	UNTERLEGSCHLEIBE	ARANDELA	G06	20
800092488	COPERCHIO CAMBIO	CHANGE GEAR COVER	COUVERCLE BOITE DE VITESSES	GETRIEBEDECKEL	TAPA CAMBIO	G11	1
800092490	MOLLA	SPRING	RESSORT	FEDER	MUELLE	G11	30
800092491	COPERCHIO SELETTORE	SELECTOR COVER	COUVERCLE SELECTEUR	DECKEL GANGWAHL	TAPA SELECTOR	G11	36
800092494	COPERCHIO CATENA	CHAIN COVER	COUVERCLE DE CHAINE	KETTENSCHUTZ	TAPA CADENA	G11	41
800092630	FERMAGLIO PER CAVI	CABLES CLIP	FIXATION POUR CABLES	KLEMMRING FÜR GASZÜGE	CLIP PARA CABLES	D03	14
800092631	ANTIVIBRANTE	VIBRATION-DAMPER	ANTI-VIBRATIONS	SCHWINGUNGSDÄMPFER	ANTIVIBRANTE	B01	21
800092642	CAVALLETTO POSTERIORE	REAR STAND	BEQUILLE ARRIERE	HINTERER STÄNDER	CABALLETE TRASERO	H01	3
800092649	MOLLA	SPRING	RESSORT	FEDER	MUELLE	G16	8
800092658	BUSSOLA	BUSH	BAGUE	HÜLSE	CASQUILLO	A01	36
800092659	VITE M5X8	SCREW M5X8	VIS M5X8	SCHRAUBE M5X8	TORNILLO M5X8	F02	10
800092660	PROTEZIONE	PROTECTION	PROTECTION	VERKLEIDUNG	PROTECCION	D02	37
800092661	FASCETTA IN NYLON	NYLON CLAMP	COLLIER EN NYLON	NYLONSCHELLE	CINTA DE NYLON	F02	17
						F06	10
						F07	22
						G08	9
800092662	BUSSOLA	BUSH	BAGUE	HÜLSE	CASQUILLO	A01	33
800092663	TAMPONE	PAD	TAMPON	PUFFER	TAPON	E02	18
800092664	DECAL	DECAL	ADHESIF	AUFKLEBER	CALCOMANIA	E03	1
800092666	TARGHETTA VETRINO	GLASS DATA PLATE	PLAQUETTE BULLE SCHILD	SCHIEBENGLAS	ETIQUETA VIDRIO	E01	13
800092667	TARGHETTA REGOLAZIONE	CHAIN ADJUSTMENT PLATE	PLAQUETTE REGLAGE	SCHILD	ETIQUETA REGULACION		
	CATENA		CHAINE	KETTENEINSTELLUNG	CADENA	B01	26
800092668	FASCETTA IN GOMMA	RUBBER CLAMP	COLLIER EN CAOUTCHOUC	GUMMISCHELLE	CINTA DE GOMA	D04	17
						F04	24
						F05	5
800092669	SEMIGUSCIO POSTERIORE	PIPES REAR HALF BEARING	PLAQUETTE DE MAINTIEN	HINTERE LEITUNGS-	SEMICASCO TRASERO		
	TUBI		CANALISATIONS	KLAMMERHÄLFTE	TUBOS	G08	71
800092670	BUSSOLA	BUSH	BAGUE	HÜLSE	CASQUILLO	B01	34
						E01	6
						E01	32
800092845	GAMBA SX COMPLETA	LH LEG ASSEMBLY	BRAS G. COMPLET	LINKES BEIN KOMPLETT	PATA HORQUILLA IZQUIERDA COMPLETA	B03	2
800092846	GAMBA DX COMPLETA	RH LEG ASSEMBLY	BRAS D. COMPLET	RECHTES BEIN KOMPLETT	PATA HORQUILLA DERECHA COMPLETA	B03	1
800092849	COPRICATENA SUPERIORE	UPPER CHAIN COVER	CARTER DE CHAINE SUPERIEUR	OBERER KETTENSCHUTZ	CUBRECADENA SUPERIOR	B01	22
800092850	BORSA ATTREZZI COMPLETA	TOOLS KIT	TROUSSE A OUTILS COMPLETE	WERKZEUGTASCHE KOMPLETT	BOLSA HERRAMIENTAS COMPLETA	H01	1
800092853	TELO COPRIMOTO	MOTORCYCLE COVER	BACHE	ABDECKPLANE FÜR MOTORRAD	LONA CUBREMOTO	H01	8
800092857	CHIAVE GHIERA	STEERING ECCENTRIC	CLE POUR ECROU	SCHLÜSSEL GEWINDERING	LLAVE VIROLA EXCENTRICO		
	ECCENTRICO STERZO	RING NUT WRENCH	DECENTRE DIR.	LENKEXZENTER	DIRECCION	J01	3
800092860	ESTRATTORE CUSCINETTI	FORK BEARING EXTRACTOR	EXTRACTEUR ROULEMENTS	AUSZIEHER	EXTRACTOR COJINETE		
	FORCELLONE		BRAS OSC.	SCHWINGENLAGER	HORQUILLA	J01	4

INDICE CODICI / DENOMINAZIONI

 CODEX / DESIGNATION INDEX • INDEX CODES / DÉNOMINATIONS
 INHALTSVERZEICHNIS CODE • ÍNDICE CÓDIGOS / DENOMINACIONES

Code	Denominazione	Description	Désignation	Bezeichnung	Descripción	Table	N°
800092861	BOCCOLA ESTRATTORE CUSCINETTI	BEARING EXTRACTOR BUSH	DOUILLE EXTRACTEUR ROULEMENTS	BUCHE LAGERAUSZIEHER	BUJE EXTRACTOR COJINETES	J01	5
800092862	ESTRATTORE CUSCINETTI RUOTA ANTERIORE	FRONT WHEEL BEARING EXTRACTOR	EXTRACTEUR ROULEMENTS ROUE AVANT	AUSZIEHER VORDERRADLAGER	EXTRACTOR COJINETES RUEDA DELANTERA	J01	6
800092863	CHIAVE CPC	CPC WRENCH	CLE CPC	SCHLÜSSEL CPC	LLAVE CPC	J01	7
800092864	ATTREZZO SOSPENSIONE ANTERIORE	FRONT SUSPENSION TOOL	OUTIL SUSPENSION AVANT	WERKZEUG VORDERRADAUFHÄNGUNG	UTIL SUSPENSION DELANTERA	J01	8
800092865	ATTREZZO BILANCIAMENTO RUOTA POSTERIORE	REAR WHEEL BALANCING TOOL	OUTIL EQUILIBRAGE ROUE ARRIERE	WERKZEUG AUSWUCHTEN HINTERRAD	UTIL BALANCEAMIENTO RUEDA TRASERA	J01	16
800092866	ATTREZZO PACCO FORCELLONE	FORK PACK TOOL	OUTIL PAQUET BRAS OSCILLANT	WERKZEUG SCHWINGENPAKET	UTIL PAQUETE HORQUILLA	J01	14
800092867	ATTREZZO PACCO BILANCIERE	EQUALIZER PACK TOOL	OUTIL PAQUET BALANCIER	WERKZEUG SCHWINGHEBELPAKET	UTIL PAQUETE BALANCIER	J02	1
800092868	ATTREZZO CUSCINETTI RUOTA ANTERIORE	FRONT WHEEL BEARINGS TOOL	OUTIL ROULEMENTS ROUE AVANT	WERKZEUG VORDERRADLAGER	UTIL COJINETE RUEDA DELANTERA	J02	2
800092872	CHIAVE PERNO RUOTA ANTERIORE	FRONT WHEEL PIN WRENCH	CLE AXE ROUE AVANT	SCHLÜSSEL LLAVE VORDERRADACHSE	PERNO RUEDA DELANTERA	J01	1
800092876	VITE M8X10	SCREW M8X10	VIS M8X10	SCHRAUBE M8X10	TORNILLO M8X10	F04	9
800092882	ROSETTA	WASHER	RONDELLE	UNTERLEGSCHIEBE	ARANDELA	B01 E01	37 16
800092886	MOLLA RITEGNO PASTIGLIE	PADS CHECK SPRING	PLAQUETTE D'APPUI	RÜCKHALTEFEDER BREMSBELÄGE	MUELLE RETENCION PASTILLAS	C02	11
800092889	TELAIETTO POSTERIORE	REAR FRAME	CADRE ARRIERE	HINTERER KLEINER RAHMEN	CHASIS TRASERO	A02	1
800092890	ECCENTRICO REGOLAZ. PEDANA DX	RH FOOTBOARD ADJUSTMENT ECCENTRIC	EXCENTRIQUE DE REGLAGE CALE-PIED D.	EINSTELLUNGSEXZENTER RECHTE FUSSRASTE	EXCENTRICO REGULACION ESTRIBO DERECHO	D02	3
800092891	ECCENTRICO REGOLAZ. PEDANA SX	LH FOOTBOARD ADJUSTMENT ECCENTRIC	EXCENTRIQUE DE REGLAGE CALE-PIED G.	EINSTELLUNGSEXZENTER LINKE FUSSRASTE	EXCENTRICO REGULACION ESTRIBO IZQUIERDO	D01	3
800092892	SEMIMANUBRIO DX	RH HALF HANDLEBAR	DEMI-GUIDON D.	RECHTE LENKERHÄLFTE	SEMIMANILLAR DERECHA	D03	1
800092893	SEMIMANUBRIO SX	LH HALF HANDLEBAR	DEMI-GUIDON G.	LINKE LENKERHÄLFTE	SEMIMANILLAR IZQUIERDA	D04	1
800092894	SEMIGUSCIO SUPERIORE	UPPER HALF BEARING	DEMI-COQUE SUPERIEURE	OBERE SCHALENHÄLFTE	SEMIGUSCIO SUPERIOR	D03	6
800093018	FUSIBILE 40A	FUSE 40A	FUSIBLE 40A	SICHERUNG 40A	FUSIBLE 40A	F04	6
800093297	VITE M5X8	SCREW M5X8	VIS M5X8	SCHRAUBE M5X8	TORNILLO M5X8	D03	10
800093298	LEVA FRIZIONE	CLUTCH LEVER	LEVIER D'EMBRAYAGE	KUPPLUNGSHEBEL	PALANCA EMBRAGUE	D04	20
800093299	PERNO PER LEVA	LEVER PIN	AXE DE LEVIER	HEBELBOLZEN	PERNO PARA PALANCA	D03 D04	26 21
800093300	DADO PER LEVA	LEVER NUT	ECROU DE LEVIER	MUTTER FÜR HEBEL	TUERCA PARA PALANCA	D03 D04	27 22
800093301	SERBATOIO OLIO FRENO ANTERIORE	FRONT BRAKE FLUID SUPPLY TANK	RESERVOIR LIQUIDE DE FREIN AVANT	BREMSFLÜSSIGKEITSBEHÄLTER VORDERRADBREMSE	DEPOSITO ACEITE FRENO DELANTERO	D03	30
800093302	DIAFRAMMA	DIAPHRAGM	DIAPHRAGME	MEMBRAN	DIAFRAGMA	D03	34
800093303	GUARNIZIONE	GASKET	JOINT	DICHTUNG	EMPAQUE	D03	35
800093306	ANELLO DI TENUTA	GROMMET	BAGUE D'ETANCHEITE	DICHTUNGSRING	RETEN	D03 D04	38 33
800093307	INTERRUPTORE FRIZIONE	CLUTCH SWITCH	CONTACTEUR EMBRAYAGE	KUPPLUNGSSCHALTER	INTERRUPTOR EMBRAGUE	D04	23
800093308	SERBATOIO OLIO POMPA FRIZIONE	CLUTCH PUMP OIL TANK	RESERV. FLUIDE MAITRE-CYLINDRE EMBRAYAGE	KUPPLUNGSFÜSSIGKEITS-BEHÄLTER	DEPOSITO ACEITE BOMBA EMBRAGUE	D04	25
800093309	SERBATOIO OLIO POMPA FRIZIONE	CLUTCH PUMP OIL TANK	RESERV. FLUIDE MAITRE-CYLINDRE EMBRAYAGE	KUPPLUNGSFÜSSIGKEITS-BEHÄLTER	DEPOSITO ACEITE BOMBA EMBRAGUE	D04	26
800093310	TAPPO	PLUG	BOUCHON	VERSCHLUSS	TAPON	D04	27
800093311	DIAFRAMMA	DIAPHRAGM	DIAPHRAGME	MEMBRAN	DIAFRAGMA	D04	29
800093312	GUARNIZIONE	GASKET	JOINT	DICHTUNG	EMPAQUE	D04	30
800093313	VITE M4X16	SCREW M4X16	VIS M4X16	SCHRAUBE M4X16	TORNILLO M4X16	D03 D04 D04	33 24 28
800093314	LEVA COMANDO FRENO POSTERIORE	REAR BRAKE LEVER	LEVIER DE COMMANDE FREIN ARRIERE	BREMSPEDALHEBEL HINTERRADBREMSE	PALANCA ACCIONAMIENTO FRENO TRASERO	D02	16

**INDICE CODICI / DENOMINAZIONI**

CODEX / DESIGNATION INDEX • INDEX CODES / DÉNOMINATIONS

INHALTSVERZEICHNIS CODE • ÍNDICE CÓDIGOS / DENOMINACIONES

Code	Denominazione	Description	Désignation	Bezeichnung	Descripción	Table	N°
800093317	COPRICATENA INFERIORE	LOWER CHAIN COVER	CARTER DE CHAINE INFERIEUR	UNTERER KETTENSCHUTZ	CUBRECADENA INFERIOR	B01	25
800093318	SEMIBIELLA SUPERIORE	UPPER HALF SUPPORT	DEMI-BIELLE SUPERIEURE	OBERE SCHUBSTANGENHÄLFTE	SEMIBIELLA SUPERIOR	B02	1
800093319	SEMIBIELLA INFERIORE	LOWER HALF SUPPORT	DEMI-BIELLE INFERIEURE	UNTERE SCHUBSTANGENHÄLFTE	SEMIBIELLA INFERIOR	B02	2
800093320	BILANCIERE COMPLETO	EQUALIZER ASSEMBLY	BALANCIER COMPLET	KIPPHEBEL KOMPLETT	BALANCIN COMPLETO	B02	9
800093323	ANELLO DI TENUTA	GROMMET	BAGUE D'ETANCHEITE	DICHTUNGSRING	RETEN	G12	19
800093324	ANELLO DI TENUTA	GROMMET	BAGUE D'ETANCHEITE	DICHTUNGSRING	RETEN	G12	20
800093328	SUPPORTO PROIETTORE ANTERIORE	HEADLIGHT SUPPORT	SUPPORT DE PROJECTEUR AVANT	SCHWEINWERFERHALTERUNG	SOPORTE PROYECTOR DELANTERO	F03	1
800093329	CAMINO DI VENTILAZIONE	VENT PIPE	CONDUIT D'AERATION	LÜFTUNGSZUG	CONDUCTO DE VENTILACION	F03	6
800093330	SUPPORTO POLIELLISSOIDALI	POLYELLIPSOID SUPPORT	SUPPORT POLYELLIPSOIDAUX	POLYELLIPSOIDHALTERUNG	SOPORTE MULTIELLIPOIDAL	F03	7
800093331	LAMPADA	BULB	AMPOULE	LAMPE	LAMPARA	F03	12
800093332	TRASPARENTE	GLASS	CABOCHON	BLINKERGLAS	TRASPARENTE	F01	6
800093333	TRASPARENTE	GLASS	CABOCHON	BLINKERGLAS	TRASPARENTE	F01	15
800093334	LENTE PER PROIETTORE	HEADLIGHT GLASS	LENTE PER PROJECTEUR	SCHWEINWERFERLINSE	LENTE PARA PROYECTOR	F03	16
800093335	FANALE POSTERIORE	TAIL LAMP	FEU ARRIERE	RÜCKLICHT	PILOTO TRASERO	F07	2
800093336	TRASPARENTE	GLASS	CABOCHON	BLINKERGLAS	TRASPARENTE	F07	13
800093337	TRASPARENTE	GLASS	CABOCHON	BLINKERGLAS	TRASPARENTE	F07	18
800093338	CHIAVE GREZZA	VIRGIN IGNITION LOCK KEY	CLE BRUTE	SCHLÜSSELROHLING	LLAVE NO ACABADA	D05	5
800093339	INTERRUTTORE ACCENSIONE CON CHIAVI	IGNITION LOCK SWITCH WITH KEYS	CONTACTEUR D'ALLUMAGE AVEC CLES	ZÜNDSCHLOSS MIT SCHLÜSSELN	INTERRUPTOR DE ENCENDIDO CON LLAVE	D05	2
800093340	TAPPO SERB. CARBURANTE CON CHIAVI	FILLERCAP WITH KEYS	BOUCHON RES. CARBURANT AVEC CLES	TANKSCHLOSS MIT SCHLÜSSELN	TAPA DEL TANQUE DEL COMBUSTIBLE CON LLAVE	D05	3
800093341	SERRATURA SELLA CON CHIAVI	SADDLE LOCK WITH KEYS	SERRURE DE SELLE AVEC CLES	SITZBANKSCHLOSS MIT SCHLÜSSELN	CERRADURA SILLIN CON LLAVE	D05	4
800093345	DADO M3	NUT M3	ECROU M3	MUTTER M3	TUERCA M3	F01	20
800093346	VITE M3X10	SCREW M3X10	VIS M3X10	SCHRAUBE M3X10	TORNILLO M3X10	F01	19
800093347	ASTA SETTAGGIO SOSPENSIONE POST.	REAR SUSPENSION ADJSUTING ROD	TIGE DE REGLAGE SUSPENSION AR.	EINSTELLSTANGE HINTERRADFEDERUNG	VARILLA AJUSTE SUSPENSION TRASERA	J02	5
800093355	RIVETTO	RIVET	RIVET	NIETE	REMACHE	E02	3
800093359	STELO SX COMPLETO	LH STEM ASSEMBLY	TUBE G. COMPLET	LINKER SCHAFT KOMPLETT	VASTAGO IZQ. COMPLETO	B05	1
800093360	STELO DX COMPLETO	RH STEM ASSEMBLY	TUBE D. COMPLET	RECHTER SCHAFT KOMPLETT	VASTAGO DER. COMPLETO	B04	1
800093361	BOCCOLA	BUSH	BAGUE	BUCHSE	CASQUILLO	B04	3
						B05	3
800093362	BOCCOLA	BUSH	BAGUE	BUCHSE	CASQUILLO	B04	4
						B05	4
800093363	DISTANZIALE	SPACER	ENTRETOISE	ABSTANDHALTER	DISTANCIADOR	B04	5
						B05	5
800093364	PARAOILIO	OIL SEAL	JOINT A LEVRE	ÖLDICHTRING	RETENEDOR DE ACEITE	B04	6
						B05	6
800093365	ANELLO RITENUTA	RETAINING RING	JONC DE MAINTIEN	SCHLISSRING	RETEN	B04	7
						B05	7
800093366	PARAPOLVERE	DUST COVER	JOINT-POUSSIÈRE	STAUBSCHUTZRING	GUARDAPOLVO	B04	8
						B05	8
800093367	VITE DI REGOLAZIONE	ADJUSTING SCREW	VIS DE REGLAGE	EINSTELLSCHRAUBE	TORNILLO DE REGULACION	B04	9
						B05	9
800093368	ANELLO DI TENUTA	GROMMET	BAGUE D'ETANCHEITE	DICHTUNGSRING	RETEN	B04	10
						B05	10
800093370	FODERO	SLEEVE	FOURREAU	HÜLSE	ENVOLTURA	B04	11
						B05	11
800093371	CARTUCCIA	CARTRIDGE	CARTOUCHE	PATRONE	CARTUCHO	B04	12
						B05	12
800093372	ANELLO RITENUTA	RETAINING RING	JONC DE MAINTIEN	SCHLISSRING	RETEN	B04	13
						B05	13

INDICE CODICI / DENOMINAZIONI

 CODEX / DESIGNATION INDEX • INDEX CODES / DÉNOMINATIONS
 INHALTSVERZEICHNIS CODE • ÍNDICE CÓDIGOS / DENOMINACIONES

Code	Denominazione	Description	Désignation	Bezeichnung	Descripción	Table	N°
800093373	ASSIEME PACCO COMPRESSIONE	COMPRESSION PACK ASSEMBLY	ENSEMBLE PAQUET COMPRESSION	BAUGRUPPE KOMPRESSIOPAKET	CONJUNTO PAQUETE COMPRESION	B04	14
						B05	14
800093374	VITE DI REGOLAZIONE	ADJUSTING SCREW	VIS DE REGLAGE	EINSTELLSCHRAUBE	TORNILLO DE REGULACION	B04	16
						B05	16
800093391	ANELLO DI CENTRAGGIO	CENTERING RING	BAGUE DE CENTRAGE	ZENTRIERRING	ANILLO DE CENTRAJE	B04	17
						B05	17
800093392	ROSETTA	WASHER	RONDELLE	UNTERLEGSCHEIBE	ARANDELA	B04	18
						B05	18
800093393	VITE FISSAGGIO CARTUCCIA	CARTRIDGE CLAMP SCREW	VIS DE FIXATION CARTOUCHE	BEFESTIGUNGSSCHRAUBE PATRONE	TORNILLO FIJACION CARTUCHO	B04	19
						B05	19
800093394	MOLLA	SPRING	RESSORT	FEDER	MUELLE	B04	20
						B05	20
800093395	Distanziale	SPACER	ENTRETOISE	ABSTANDHALTER	DISTANCIADOR	B04	21
						B05	21
800093396	BOCCOLA	BUSH	BAGUE	BUCHSE	CASQUILLO	B04	22
						B05	22
800093397	ROSETTA	WASHER	RONDELLE	UNTERLEGSCHEIBE	ARANDELA	B04	23
						B05	23
800093398	TAPPO COMPLETO	PLUG ASSEMBLY	BOUCHON COMPLET	VERSCHLUSS KOMPLETT	TAPON COMPLETO	B04	24
						B05	24
800093399	ANELLO DI TENUTA	GROMMET	BAGUE D'ETANCHEITE	DICHTUNGSRING	RETEN	B04	25
						B05	25
800093400	ANELLO DI TENUTA	GROMMET	BAGUE D'ETANCHEITE	DICHTUNGSRING	RETEN	B04	26
						B05	26
800093401	ANELLO DI TENUTA	GROMMET	BAGUE D'ETANCHEITE	DICHTUNGSRING	RETEN	B04	27
						B05	27
800093402	ANELLO ELASTICO	SNAP RING	CIRCLIP	SPRENGRING	ANILLO ELASTICO	B04	28
						B05	28
800093403	STELO CON PIEDINO SX	STEM WITH LH FOOT	TUBE AVEC BASE G.	LINKER SCHAFT MIT FUSS	VASTAGO CON PIE' IZQ.	B05	2
800093404	STELO CON PIEDINO DX	STEM WITH RH FOOT	TUBE AVEC BASE D.	RECHTER SCHAFT MIT FUSS	VASTAGO CON PIE' DER.	B04	2
800093406	ADESIVO SHOWA	SHOWA STICKER	ADHESIF SHOWA	AUFKLEBER SHOWA	ADHESIVO SHOWA	B04	29
						B05	29
800093410	CONVOGLIATORE POMPA BENZINA	FUEL PUMP CONVEYOR	CONVOYEUR POMPE A ESSENCE	ZULEITUNG BENZINPUMPE	TRANSPORTADOR BOMBA GASOLINA	G12	10
800093411	ANELLO DI SICUREZZA	SAFETY RING	JONC	SICHERUNGSRING	ANILLO DE SEGURIDAD	G12	11
800093414	PORTADOCUMENTI	DOCUMENT HOLDER	POCHETTE POUR PAPIERS	DOKUMENTENMAPPE	PORTADOCUMENTOS	H01	6
800093416	VITE AUTOFILETTANTE 2,9X16	TAPPING SCREW 2,9X16	VIS TARAUD 2,9X16	BLECHSCHRAUBE 2,9X16	TORNILLO AUTOENRROSCANTE 2,9X16	F07	15
						F07	15
800093417	PORTALAMPADA	LAMP HOLDER	DOUILLE D'AMPOULE	LAMPENHALTERUNG	PORTALAMPARA	F01	7
800093418	LAMPADA	BULB	AMPOULE	LAMPE	LAMPARA	F01	8
800093419	GUARNIZIONE RETROVISORE SX	LH REARVIEW MIRROR GASKET	JOINT RETROVISEUR G.	LINKE RÜCKSPIEGELDICHTUNG	EMPAQUE RETROVISOR IZQUIERDO	F01	16
						F01	16
800093420	GUARNIZIONE RETROVISORE DX	RH REARVIEW MIRROR GASKET	JOINT RETROVISEUR D.	RECHTE RÜCKSPIEGELDICHTUNG	EMPAQUE RETROVISOR DERECHO	F01	12
						F01	12
800093851	VITE AUTOFILETTANTE 3,5X9,5	TAPPING SCREW 3,5X9,5	VIS TARAUD 3,5X9,5	BLECHSCHRAUBE 3,5X9,5	TORNILLO AUTOENRROSCANTE 3,5X9,5	F01	10
						F01	10
800093852	BASE DI STERZO CON PERNO	STEERING BASE WITH PIN	TETE INFERIEUR AVEC AXE	LENKAUFLAGE MIT ZAPFEN	BASE DE LA DIRECCION CON PERNO	B03	4
						B03	4
800093854	FORCELLONE POSTERIORE	REAR FORK	BRAS OSCILLANT	HINTERE SCHWINGE	HORQUILLA TRASERA	B01	1
800093855	COPRICATENA INFERIORE	LOWER CHAIN COVER	CARTER DE CHAINE INFERIEUR	UNTERER KETTENSCHUTZ	CUBRECADENA INFERIOR	B01	25
800093862	COPRI INTERRUPTORE ACCENSIONE	IGNITION LOCK SWITCH COVER	CACHE CONTACTEUR D'ALLUMAGE	ZÜNDSCHLOSSABDECKUNG	CUBRE INTERRUPTOR DE ENCENDIDO	A01	27
						A01	27
800093864	MAGLIA GIUNZIONE CATENA	CHAIN LINK	MAILLON DE JONCTION CHAINE	KETTENSCHLOSS	ESLABON UNION CADENA	C01	2

INDICE CODICI / DENOMINAZIONI

CODEX / DESIGNATION INDEX • INDEX CODES / DÉNOMINATIONS

INHALTSVERZEICHNIS CODE • ÍNDICE CÓDIGOS / DENOMINACIONES

Code	Denominazione	Description	Désignation	Bezeichnung	Descripción	Table	N°
800093877	SOFTWARE DIAGNOSTICA	DIAGNOSTIC SOFTWARE	LOGICIEL DIAGNOSTIC	DIAGNOSE-SOFTWARE	SOFTWARE DIAGNOSTICA	J03	6
800093990	ALBERO SECONDARIO	TRANSMISSION SHAFT	ARBRE SECONDAIRE	VORGELEGEWELLE	ARBOL SECUNDARIO	G10	16
800094018	TARGHETTA "RUMORE"	"NOISE" DATA PLATE	PLAQUETTE "BRUIT"	SCHILD "GERÄUSCHBELASTUNG"	ETIQUETA "RUIDOS"	K01	2
800094019	TARGHETTA "RETROVISORE"	"REARVIEW" MIRROR DATA PLATE	PLAQUETTE "RETROVISEUR"	SCHILD "RÜCKSPIEGEL"	ETIQUETA "RETROVISORES"	K01	7
800094020	TARGHETTA "VETRINO"	"GLASS" DATA PLATE	PLAQUETTE "BULLE"	SCHILD "SCHEIBENGLAS"	ETIQUETA "VIDRIO"	E01	13
800094022	PINZA FRENO ANTERIORE DX	RH FRONT BRAKE CALIPER	ETRIER DE FREIN AVANT D.	VORDERER RECHTER BREMSSATTEL	PINZA FRENO DELANTERA DERECHA	C02	15
800094023	PINZA FRENO ANTERIORE SX	LH FRONT BRAKE CALIPER	ETRIER DE FREIN AVANT G.	VORDERER LINKER BREMSSATTEL	PINZA FRENO DELANTERA IZQUIERDA	C02	9
800094024	COPPIA PASTIGLIE FRENO ANTERIORE	FRONT BRAKE PADS	PAIRE DE PLAQUETTES FREIN AVANT	BREMSBELAGPAAR VORDERRADBREMSE	PAR DE PASTILLAS FRENO DELANTERO	C02	10
800094025	POMPA FRENO ANTERIORE	FRONT BRAKE PUMP	MAITRE-CYLINDRE FREIN AVANT	BREMSPUMPE VORDERRADBREMSE	BOMBA FRENO DELANTERO	D03	18
800094030	PROTEZIONE FERMAGLIO	CLIP PROTECTION	PROTECTION	KLEMMRINGSICHERUNG	PROTECCION CLIP	C01	36
800094116	RELE' INIEZIONE	INJECTION RELAY	RELAIS D'INJECTION	EINSPRITZRELAIS	RELE' INYECCION	F06	17
800094164	TELAJETTO POSTERIORE	REAR FRAME	CADRE ARRIERE	HINTERER KLEINER RAHMEN	CHASIS TRASERO	A03	1
800094170	MOLLA	SPRING	RESSORT	FEDER	MUELLE	A03	33
800094171	BUSSOLA ROTAZIONE PEDANA POSTERIORE	REAR FOOTBOARD SWING BUSH	BAGUE ROTATION CALE-PIED ARRIERE	DREHBUCHSE HINTERE FUSSRASTE	CASQUILLO ROTACION ESTRIBO TRASERO	A03	29
800094172	TRASMISSIONE SERRATURA	LOCK TRANSMISSION	TRANSMISSION DE SERRURE	SEILZUG SCHLIESSVORRICHTUNG	TRANSMISION CERRADURA	E05	7
800094173	CODONE	TAIL	COQUE ARRIERE	HECKTEIL	COLA	E05	16
800094174	PARATIA PARACALORE	HEAT GUARD	PAROI ISOLANTE	HITZESCHUTZELEMENT	MAMPARO PARACALOR	A02 A03	25 15
800094176	SELLA PASSEGGERO	PILLION	SELLE PASSAGER	BEIFAHRERSITZ	SILLIN PASAJERO	E05	27
800094178	CINGHIA DI TRATTENUTA	HOLDING BELT	SANGLE	HALTERIEMEN	CORREA DE RETENCION	E05	28
800094179	SUPPORTO ANTERIORE CODONE	TAIL FRONT SUPPORT	SUPPORT AVANT COQUE ARRIERE	VORDERE HECKTEILHALTERUNG	SOPORTE DELANTERO COLA	E05	34
800094182	ANTIVIBRANTE	VIBRATION-DAMPER	ANTI-VIBRATIONS	SCHWINGUNGSDÄMPFER	ANTIVIBRANTE	E05	36
800094184	TUBO TERMOSTATO/ RADIATORE	THERMOSTAT/RADIATOR PIPE	CANALISATION THERMOSTAT/RADIATEUR	LEITUNG THERMOSTAT/ KÜHLER	TUBO TERMOSTATO/ RADIADOR	G08	45
800094185	TUBO RADIATORE/POMPA	RADIATOR/PUMP PIPE	CANALISATION RADIATEUR/ POMPE	LEITUNG KÜHLER/ PUMPE	TUBO RADIADOR /BOMBA	G08	54
800094186	TUBO CARICAMENTO RADIATORE	RADIATOR FILLING PIPE	CANALISATION DE REMPLISSAGE RADIATEUR	ZULEITUNG KÜHLER	TUBO CARGA RADIADOR	G08	42
800094187	AMMORTIZZATORE POST.	REAR SHOCK ABSORBER	AMORTISSEUR ARRIERE	HINTERER STOSSDÄMPFER	AMORTIGUADOR TRASERO	B02	17
800094194	SERRATURA SELLA	SADDLE LOCK	SERRURE DE SELLE	SITZBANKSCHLOSS	CERRADURA SILLIN	E05	12
800094275	FLANGIA INFERIORE SERBATOIO	FUEL TANK LOWER FLANGE	PLATEAU INFERIEUR DU RESERVOIR	UNTERE TANKFLANSCH	SOPORTE INFERIOR DEPOSITO	G12	1
800094276	TAMPONE DI APPOGGIO	SUPPORTING PAD	TAMPON D'APPUI	AUFLAGEPUFFER	TAPON DE APOYO	A02 A03	4 4
800094313	ROSETTA	WASHER	RONDELLE	UNTERLEGSCHIBE	ARANDELA	A02 A03	5 5
800094318	COPRIMANOPOLA	KNOB COVER	GAINÉ POUR POIGNEES	HANDGRIFFSCHUTZ	CUBRE PUÑO	H01	2
800094439	RELE' GENERALE	MAIN RELAY	RELAIS GENERALE	HAUPTRELAIS	RELE' GENERAL	F04	3
800094505	RITEGNO PER BATTERIA	BATTERY HOLDER	CALE POUR BATTERIE	BEFESTIGUNG FÜR BATTERIE	SUJETADOR PARA BATERIA	E04 E05	26 24
800094506	FLANGIA PORTATARGA/ CATADIOTTO	NUMBER PLATE HOLDER/ RETROREFLECTOR	FLASQUE SUPPORT DE PLAQUE/FLANGE REFLECTEUR	BEFESTIGUNGSFLANSCH NUMMERN SCHILDBEFESTI- GUNG/KATZENAUGE	BRIDA PORTAPLACA/ CATAFARROS	A02 A03	18 20
800094507	PROIETTORE ANTERIORE	HEADLIGHT	PROJECTEUR AVANT	SCHEINWERFER	PROYECTOR DELANTERO	F02	1
800094509	PROIETTORE ANTERIORE	HEADLIGHT	PROJECTEUR AVANT	SCHEINWERFER	PROYECTOR DELANTERO	F02	1
800094512	PERNO	PIN	AXE	ZAPFEN	PERNO	E05	13
800094517	ANTIVIBRANTE	VIBRATION-DAMPER	ANTI-VIBRATIONS	SCHWINGUNGSDÄMPFER	ANTIVIBRANTE	G08	2

INDICE CODICI / DENOMINAZIONI

 CODEX / DESIGNATION INDEX • INDEX CODES / DÉNOMINATIONS
 INHALTSVERZEICHNIS CODE • ÍNDICE CÓDIGOS / DENOMINACIONES

Code	Denominazione	Description	Désignation	Bezeichnung	Descripción	Table	N°
800094521	KIT DI FISSAGGIO POLIELLISSOIDALI	POLYELLIPSOIDS FIXING KIT	KIT DE FIXATION	BAUSATZ	KIT FIJACION		
			POLYELLIPSOIDAUX	POLYELLIPSOIDHALTERUNG	MULTIELIPSOIDAL	F03	11
800094522	POLIELLISSOIDALE ANABBAGLIANTE	POLYELLIPSOIDAL LOWER BEAM	POLYELLIPSOIDAL CODE	POLYELLIPSOID ABBLENDLICHT	MULTIELIPSOIDAL LUZ DE CARRETERA	F03	10
800094523	POLIELLISSOIDALE ANABBAGLIANTE	POLYELLIPSOIDAL LOWER BEAM	POLYELLIPSOIDAL CODE	POLYELLIPSOID ABBLENDLICHT	MULTIELIPSOIDAL LUZ DE CRUCE	F03	10
800094526	KIT FISSAGGIO GRUPPO OTTICO	OPTICAL UNIT FIXING KIT	KIT FIXATION GROUPE OPTIQUE	BAUSATZ HALTERUNG OPTISCHE EINHEIT	KIT FIJACION GRUPO OPTICO	F03	2
800094529	TUBO COMANDO GAS CON MANOPOLE	THROTTLE CONTROL PIPE WITH KNOBS	TUBE COMMANDE GAZ AVEC POIGNEES	ROHR GASGRIF MIT HANDGRIF	TUBO MANDO GAS CON PUÑO	D03	11
800094626	ANELLO DI TENUTA	GROMMET	BAGUE D'ETANCHEITE	DICHTUNGSRING	RETEN	G01	47
800094632	CERCHIO RUOTA ANTERIORE	FRONT RIM	JANTE ROUE AVANT	VORDERRADFELGE	LLANTA RUEDA DELANTERA	C02	1
800094637	KIT DI FISSAGGIO POLIELLISSOIDALI	POLYELLIPSOIDS FIXING KIT	KIT DE FIXATION	BAUSATZ	KIT FIJACION		
			POLYELLIPSOIDAUX	POLYELLIPSOIDHALTERUNG	MULTIELIPSOIDAL	F03	11
800094640	COMANDO GAS COMPLETO	THROTTLE CONTROL ASSEMBLY	COMMANDE GAZ COMPLETE	GASGRIF KOMPLETT	MANDO GAS COMPLETO	D03	5
800094643	ANELLO ELASTICO	SNAP RING	CIRCLIP	SPRENGRING	ANILLO ELASTICO	D03 D04	40 35
800094651	DADO ELASTICO M4	SPRING NUT M4	ECROU AUTOFREINE M4	ELASTISCHE MUTTER M4	TUERCA ELASTICA M4	E02	11
800094792	ATTREZZO MONTAGGIO CAMBIO	CHANGE GEAR ASSEMBLY TOOL	OUTIL MONTAGE BOITE DE VITESSES	WERKZEUG GETRIEBEMONTAGE	UTIL MONTAJE CAMBIO	J03	1
800094794	ATTREZZO SUPPORTO PARASTRAPPI	SPRING DRIVE SUPPORT TOOL	OUTIL SUPPORT FLECTEUR	WERKZEUG HALTERUNG REISSSCHUTZ FLEXIBLE	UTIL SOPORTE ACOPLAMIENTO	J03	10
800094795	ATTREZZO RINVIO ALBERO ALTERNATORE	ALTERNATOR SHAFT TRANSMISSION TOOL	OUTIL RENVOI ARBRE ALTERNATEUR	WERKZEUG VORGELEGE LICHTMASCHINENWELLE	UTIL REENVIO EJE ALTERNADOR	J03	9
800094796	ATTREZZO MONTA/SMONTA VALVOLE	VALVES ASSEMBLY/ DISASSEMBLY TOOL	OUTIL LEVE-SOUPAPE	WERKZEUG ZUM EIN-/AUSBAU VENTILE	UTIL MONTAJE DESMONTAJE VALVULA	J03	14
800094797	LASTRA SAGOMATA COPRI TESTA	HEAD COVER SHAPED PLATE	PLAQUE COUVRE-CULASSE	ABDECKSCHABLONE L ZYLINDERKOPF	AMINA PERFILADA CUBRE CULATA	J03	8
800094798	ATTREZZO GOMMINI VALVOLA	VALVE RUBBER RINGS TOOL	OUTIL CAOUTCHOUC SOUPAPE	WERKZEUG VENTILGUMMI	UTIL CAUCHOS VALVULA	J03	11
800094860	LAMPADA	BULB	AMPOULE	LAMPE	LAMPARA	F02	15
800094861	LAMPADA	BULB	AMPOULE	LAMPE	LAMPARA	F02	16
800094890	CAPPUCCIO POLO POSITIVO BATTERIA	BATTERY POSITIVE POLE CAP	CAPUCHON POLE POSITIF BATTERIE	KAPPE PLUSPOL BATTERIE	CAPUCHON POLO POSITIVO BATERIA	F04	25
800094895	TAPPO	PLUG	BOUCHON	VERSCHLUSS	TAPON	B01	33
800094896	CAPPUCCIO	CAP	CAPUCHON	KAPPE	CAPUCHON	G01	37
800094898	TAMPONE	PAD	TAMPON	PUFFER	TAPON	E02	25
800094899	INSERTO DX PER CODONE	TAIL RH INSERT	INSERT D. COQUE ARRIERE	RECHTER EINSATZ FÜR HECKTEIL	INJERTO DERECHO PARA COLA	E04 E05	29 20
800094918	ATTREZZO PARAPOLVERE E PARAOLIO	DUST COVER AND OIL SEAL TOOL	OUTIL JOINT-POUSSIERE ET JOINT A LEVRE	WERKZEUG STAUBSCHUTZRINGE UND ÖLDICHRINGE	UTIL GUARDAPOLVO Y RETEN DEL ACEITE	J01	11
800094919	ATTREZZO MOLLA	SPRING TOOL	OUTIL RESSORT	WERKZEUG FEDER	UTIL MUELLE	J01	10
800094920	ATTREZZO CARTUCCIA	CARTRIDGE TOOL	OUTIL CARTOUCHE	WERKZEUG PATRONE	UTIL CARTUCHO	J01	9
800095353	GRUPPO PRINCIPALE CAVI	MAIN CABLES SET	FAISCEAU PRINCIPAL	HAUPTKABELSTRANG	GRUPO CABLES PRINCIPALES	F01	4
800095366	TARGHETTA BENZINA	FUEL DATA PLATE	PLAQUETTE ESSENCE	SCHILD BENZIN	ETIQUETA GASOLINA	K01	8
800095382	DISTANZIALE	SPACER	ENTRETOISE	ABSTANDHALTER	DISTANCIADOR	E05	39
800095389	ATTREZZO CATENA	CHAIN TOOL OUTIL	CHAINE	WERKZEUG KETTE	UTIL CADENA	J02	3
800095390	PERNO TAGLIO E RIBADITURA	RIVETING AND CUTTING PIN	AXE COUPE ET RIVETAGE	SCHNITT- UND NIETZAPFEN	PERNO CORTE Y REMACHADO	J02	4
800095429	TAMPONE CONTROLLO	CONTROL PAD	TAMPON CONTROLE	KONTROLLPUFFER	TAPON CONTROL	J03	16
800095482	PUNTALINO	FAIRING POINT	COQUE	AUFLAGE	PUNTA	G08	22
800095484	CATADIOTTRO	RETROREFLECTOR	REFLECTEUR	KATZENAUGE	CATAFARO	K01	5
800095485	CATADIOTTRO	RETROREFLECTOR	REFLECTEUR	KATZENAUGE	CATAFARO	K01	6
800095486	CATADIOTTRO	RETROREFLECTOR	REFLECTEUR	KATZENAUGE	CATAFARO	K01	3
800095487	CATADIOTTRO	RETROREFLECTOR	REFLECTEUR	KATZENAUGE	CATAFARO	K01	4

INDICE CODICI / DENOMINAZIONI

CODEX / DESIGNATION INDEX • INDEX CODES / DÉNOMINATIONS

INHALTSVERZEICHNIS CODE • ÍNDICE CÓDIGOS / DENOMINACIONES

Code	Denominazione	Description	Désignation	Bezeichnung	Descripción	Table	N°
800095488	SCODELLINO	CAP	COUPELLE	FEDERTELLER	PLATILLO	E05	35
800095489	ELETTOVENTOLA SUPERIORE	UPPER HEATER FAN	ELECTROVENTILATEUR SUPERIEUR	OBERES KÜHLGEBLÄSE	ELECTROVENTILADOR SUPERIOR	G08	5
800095490	SUPPORTO ELETTOVENTOLA	HEATER FAN SUPPORT	SUPPORT HALTERUNG ELECTROVENTILATEUR	KÜHLGEBLÄSE	SOPORTE ELECTROVENTILADOR	G08	6
800095494	SUPPORTO STAFFA RADIATORE	RADIATOR SUPPORT	SUPPORT BRIDE RADIATEUR	KÜHLERBEFESTIGUNG	SOPORTE RADIADOR	G08	28
800095499	INSERTO SX PER CODONE	TAIL LH INSERT	INSERT G. COQUE ARRIERE	LINKER EINSATZ FÜR HECKTEIL	INJERTO IZQ. PARA COLA	E04 E05	30 21
800095500	ANTIVIBRANTE	VIBRATION-DAMPER	ANTI-VIBRATIONS	SCHWINGUNGSDÄMPFER	ANTIVIBRANTE	F07	5
800095502	TUBO RITORNO SCAMBIATORE	EXCHANGER RETURN PIPE	CANALISATION RETOUR ECHANGEUR	RÜCKLEITUNG WÄRMETAUSCHER	TUBO RETORNO CAMBIADOR	G08	76
800095503	PIASTRINA SX	LH PLATE	PLAQUETTE G.	LINKES BLECH	PLACA IZQ.	G08	78
800095504	PIASTRINA DX	RH PLATE	PLAQUETTE D.	RECHTES BLECH	PLACA DER.	G08	67
800095505	ROSETTA	WASHER	RONDELLE	UNTERLEGSCHEIBE	ARANDELA	G06	18
800095508	VITE AUTOFILETTANTE 6X18	TAPPING SCREW 6X18	VIS TARAUD 6X18	BLECHSCHRAUBE 6X18	TORNILLO AUTOENROSCANTE 6X18	E05	15
800095581	PUNZONE MONTAGGIO TENUTE VALVOLA	VALVE SEAL ASSEMBLY TOOL	POUSSOIR MONTAGE JOINTS SOUPAPES	SCHLAGDORN VENTILDICHTUNGEN	MONTAGE PUNZON MONTAJE ESTANQUEIDAD VALVULA	J03	17
800095803	PROTEZIONE SERBATOIO	FUEL TANK PROTECTION	PROTECTION DERESERVOIR	BENZINTANK ABDECKUNG	PROTECCION PARA DEPOSITO	E03	14
800095804	TAMPONE	PAD	TAMPON	PUFFER	TAPON	G08	23
800095807	CAVALLETTO ANTERIORE	FRONT STAND	BEQUILLE AVANT	VORDERER STÄNDER	CABALLETE DELANTERO	J02	6
800095808	PERNO CAVALLETTO ANTERIORE	FRONT STAND PIN	AXE BEQUILLE AVANT	VORDERER STÄNDERBOLZEN	PERNO CABALLETE DELANTERO	J02	7
800095816	GUARNIZIONE	GASKET	JOINT	DICHTUNG	EMPAQUE	E02	24
800095817	ROSETTA	WASHER	RONDELLE	UNTERLEGSCHEIBE	ARANDELA	F01	26
800095828	ANTIVIBRANTE	VIBRATION-DAMPER	ANTI-VIBRATIONS	SCHWINGUNGSDÄMPFER	ANTIVIBRANTE	A03 E04 E05	37 32 19
800095829	GUARNIZIONE	GASKET	JOINT	DICHTUNG	EMPAQUE	A02 A03	26 16
800095839	TAPPO	PLUG	BOUCHON	VERSCHLUSS	TAPON	K02	8
800095840	TARGHETTA SERBATOIO	FUEL TANK DATA PLATE	PLAQUETTE RESERVOIR	SCHILD TANK	ETIQUETA DEPOSITO	E03	29
800095842	TARGHETTA MARCE	GEARS DATA PLATE	PLAQUETTE VITESSES	SCHILD GÄNGE	ETIQUETA MARCHAS	K01	9
800095845	SILENZIATORI DI SCARICO	SILENCERS	SILENCIEUX D'ECHAPPEMENT	SCHALLDÄMPFER	SILENCIADOR DE ESCAPE	G16	15
800095850	PINZA MONTA/SMONTA FASCETTE CLIC	CLIC CLAMPS ASSEMBLY/ DISASSEMBLY PLIERS	PINCE POUR COLLIERS CLIC	ZANGE EIN-/ AUSBAU SCHELLEN CLIC	PINZA MONTAJE/ DESMONTAJE ABRAZADERAS	J01	12
800095906	CANDELA NGK CR9EB	SPARK PLUG NGK CR9EB	BOUGIE NGK CR9EB	ZÜNDKERZE NGK CR9EB	BUJIA NGK CR9EB	G15	15
800095960	ALBERO PRIMARIO	MAIN SHAFT ASSEMBLY	ARBRE PRIMAIRE	HAUPTANTRIEBSWELLE	ARBOL PRIMARIO	G17	1
800095961	ALBERO PRIMARIO COMPLETO	MAIN SHAFT ASSEMBLY	ARBRE PRIMAIRE COMPLET	HAUPTANTRIEBSWELLE KOMPLETT	ARBOL PRIMARIO COMPLETO	G17	2
800095962	INGRANAGGIO 5°	5TH GEAR	PIGNON 5°	ZAHNRAD 5. GANG	ENGRANAJE 5°	G17	7
800095964	INGRANAGGIO 6°	6TH GEAR	PIGNON 6°	ZAHNRAD 6. GANG	ENGRANAJE 6°	G17	12
800095965	INGRANAGGIO 2°	2ND GEAR	PIGNON 2°	ZAHNRAD 2. GANG	ENGRANAJE 2°	G17	13
800095966	ALBERO SECONDARIO COMPLETO	TRANSMISSION SHAFT ASSEMBLY	ARBRE SECONDAIRE COMPLET	VORGELEGEWELLE KOMPLETT	ARBOL SECUNDARIO COMPLETO	G17	16
800095967	INGRANAGGIO 2°	2ND GEAR	PIGNON 2°	ZAHNRAD 2. GANG	ENGRANAJE 2°	G17	19
800095968	INGRANAGGIO 6°	6TH GEAR	PIGNON 6°	ZAHNRAD 6. GANG	ENGRANAJE 6°	G17	22
800095970	INGRANAGGIO 4°	4TH GEAR	PIGNON 4°	ZAHNRAD 4. GANG	ENGRANAJE 4°	G17	26
800095971	INGRANAGGIO 5°	5TH GEAR	PIGNON 5°	ZAHNRAD 5. GANG	ENGRANAJE 5°	G17	27
800095972	INGRANAGGIO 1°	1ST GEAR	PIGNON 1°	ZAHNRAD 1. GANG	ENGRANAJE 1°	G17	30
800096426	INGRANAGGIO PRIMARIA - ALTERNATORE	MAIN GEAR - ALTERNATOR GEAR	PIGNON PRIMAIRE - ALTERNATEUR	ZAHNRAD ANTRIEBSWELLE - LICHTMASCHINE	ENGRANAJE PRIMARIO - ALTERNADOR	G09	16
800096455	COMMUTATORE SX	LH SWITCH	COMODO G.	LINKER WECHSELSCHALTER	CONMUTADOR IZQ.	D04	10

INDICE CODICI / DENOMINAZIONI

 CODEX / DESIGNATION INDEX • INDEX CODES / DÉNOMINATIONS
 INHALTSVERZEICHNIS CODE • ÍNDICE CÓDIGOS / DENOMINACIONES

Code	Denominazione	Description	Désignation	Bezeichnung	Descripción	Table	N°
800096458	FASCETTA CLIC	SCREW CLIC CLAMP	COLLIER CLIC	SCHRAUBENSCHELLE CLIC	ABRAZADERA CLIC	G13	23
						K02	13
						K02	24
800096565	ROSETTA	WASHER	RONDELLE	UNTERLEGSCHLEIBE	ARANDELA	G17	39
800096586	INGRANAGGIO 3°-4°	3RD-4TH GEAR	PIGNON 3°-4°	ZAHNRAD 3.GANG-4.GANG	ENGRANAJE 3°-4°	G17	9
800096598	CATENA DISTRIBUZIONE APERTA	OPEN TIMING CHAIN	CHAINE DISTRIBUTION OUVERTE	VENTILSTEUERKETTE OFFEN	CADENA DISTRIBUCION ABIERTA	G05	6
800096618	CUSCINETTO	BEARING	ROULEMENT	LAGER	COJINETE	G17	6
						G17	18
						G17	24
800096629	ROSETTA	WASHER	RONDELLE	UNTERLEGSCHLEIBE	ARANDELA	G17	5
						G17	20
						G17	23
800096692	ROSETTA	WASHER	RONDELLE	UNTERLEGSCHLEIBE	ARANDELA	G17	28
800096738	CONDOTTO MANDATA OLIO	OIL DELIVERY DUCT	CONDUIT REFOULEMENT HUILE	ÖL-ZULEITUNG	CONDUCTO ENVIO ACEITE	G06	15
800096747	TAPPO	PLUG	BOUCHON	VERSCHLUSS	TAPON	G01	53
800097077	CAPPUCCIO	CAP	CAPUCHON	KAPPE	CAPUCHON	E05	14
800097083	CANISTER COMPLETO	CARBON CANISTER ASSEMBLY	CANISTER COMPLET	CARBONKANISTER KOMPLETT	CANISTER COMPLETO	K02	1
800097086	PIASTRINA CENTRAGGIO CANISTER	CANISTER CENTERING PLATE	PLAQUETTE DE CENTRAGE DU CANISTER	CARBONKANISTER-ZENTRIERENPLATTE	PLACA PARA CENTRO CANISTER	K02	3
800097088	RACCORDO A 5 VIE	5-WAY FITTING	RACCORD A 5 DIRECTIONS	5-WEISE ANSCHLUSS	RACOR A 5 VIAS	K02	20
800097089	TUBO IN GOMMA	HOSE	DURIT	GUMMISCHLAUCH	TUBO DE GOMA	K02	5
800097090	TUBO IN GOMMA	HOSE	DURIT	GUMMISCHLAUCH	TUBO DE GOMA	K02	21
800097102	CRUSCOTTO COMPLETO	DASHBOARD ASSEMBLY	COMBINE DE BORD COMPLET	ARMATURENBRETT KOMPLETT	TABLERO COMPLETO	F02	9
800097110	TUBO RITORNO SCAMBIATORE	EXCHANGER RETURN PIPE	CANALISATION RETOUR ECHANGEUR	RÜCKLEITUNG WÄRMETAUSCHER	TUBO RETORNO CAMBIADOR	G08	80
800097250	TESTA CILINDRI COMPLETA	CYLINDER HEAD ASSEMBLY	CULASSE COMPLETE	ZYLINDERKOPF KOMPLETT	CULATA COMPLETA	G04	1
800097278	STAFFA ALTERNATORE	ALTERNATOR CLAMP	BRIDE ALTERNATEUR	BEFESTIGUNG LICHTMASCHINE	BRIDA ALTERNADOR	G15	5
800097867	SUPPORTO MOTORE	ENGINE MOUNTING	SUPPORT MOTEUR	MOTORHALTER	SOPORTE MOTOR	J03	19
800097884	GRAFFETTA	CLIP	PLAQUETTE	KLEMME	GRAPA	G08	38
800097885	VITE INTERRUPTORE ACCENSIONE	IGNITION LOCK SWITCH SCREW	VIS CONTACTEUR D'ALLUMAGE	SCHRAUBE ZÜNDSCHLOSS	TORNILLO INTERRUPTOR ENCENDIDO	A01	24
800097886	WORLD DEALER GUIDE	WORLD DEALER GUIDE	WORLD DEALER GUIDE	WELTWEITES HÄNDLERVERZEICHNIS	WORLD DEALER GUIDE	H01	9
800097887	ATTREZZO CUSCINETTO PERNO STERZO	STEERING PIN BEARING TOOL	OUTIL ROULEMENT DIRECTION	WERKZEUG UTIL LENKLAGERZAPFEN	COJINETE PERNO DIRECCION	J02	8
800097888	PIASTRA DI RISCONTRO BASE DI STERZO	STEERING BASE CONTROL PLATE	PLAQUE D'APPUI TE INFERIEUR	AUFLAGEPLATTE LENKBASIS	PLACA DE CONTACTO BASE DIRECCION	J02	9
800097889	ESTRATTORE CUSCINETTO STERZO	STEERING BEARING EXTRACTOR	EXTRACTEUR ROULEMENT DIRECTION	AUSZIEHER LENKLAGER DIRECTION	EXTRACTOR COJINETE DIRECCION	J02	10
800097890	ATTREZZO MONTAGGIO CUSCINETTO STERZO	STEERING BEARING ASSEMBLY TOOL	OUTIL MONT. ROULEMENT DIRECTION	WERKZEUG MONTAGE LENKLAGER	UTIL MONTAJE COJINETE DIRECCION	J02	11
800097895	TERMORIFLETTENTE	THERMOREFLECTOR	THERMOREFLECTEUR	HITZESCHUTZ	TERMOREFLECTANTE	E01	33
800097900	PIASTRA DX TELAIO	CHASSIS RH PLATE	PLAQUE D. CADRE	RECHTE RAHMENPLATTE	PLACA DERECHA BASTIDOR	A01	9
800097917	CORNETTO DI ASPIRAZIONE	INTAKE DUCT	CONE D'ADMISSION	ANSAUGSTUTZEN	TUBO DE ASPIRACION	G13	15
800097918	VALVOLA (ASPIRAZIONE)	VALVE (INTAKE)	SOUPAPE (ADMISSION)	VENTIL (EINLASS)	VALVULA (ESCAPE)	G04	8
800097919	VALVOLA (SCARICO)	VALVE (EXHAUST)	SOUPAPE (ECHAPPEMENT)	VENTIL (AUSLASS)	VALVULA (ESCAPE)	G04	9
800098020	GRUPPO CILINDRI	CYLINDERS ASSEMBLY	GROUPE CYLINDRES	ZYLINDEREINHEIT	CONJUNTO CILINDROS	G03	1
800098021	PISTONE COMPLETO	PISTON ASSEMBLY	PISTON COMPLET	KOLBEN KOMPLETT	PISTON COMPLETO	G03	2
800098023	GRUPPO SEGMENTI PISTONE	PISTON RING ASSEMBLY	GROUPE SEGMENTS PISTON	BAUGRUPPE KOLBENRINGE	CONJUNTO AROS DEL PISTON	G03	3
800098027	SPINOTTO	PISTON PIN	AXE DE PISTON	KOLBENBOLZEN	PERNO DEL PISTON	G03	4
800098028	ANELLO ELASTICO	SNAP RING	CIRCLIP	SPRENGRING	ARO	G03	10
800098034	PIGNONE CATENA	CHAIN SPROCKET	PIGNON DE CHAINE	KETTENRITZEL	PIÑON CADENA	G10	31
						G17	32

INDICE CODICI / DENOMINAZIONI

CODEX / DESIGNATION INDEX • INDEX CODES / DÉNOMINATIONS

INHALTSVERZEICHNIS CODE • ÍNDICE CÓDIGOS / DENOMINACIONES

Code	Denominazione	Description	Désignation	Bezeichnung	Descripción	Table	N°
800098149	VITE FISSAGGIO TAMBURO SELETTORE	SELECTING DRUM CLAMP SCREW	VIS FIXATION TAMBOUR DE SELECTION	BEFESTIGUNGSSCHRAUBE GANGWAHLTROMMEL	TORNILLO FIJACION TAMBOR SELECTOR	G11	21
800098167	PARAOILIO	OIL SEAL	JOINT A LEVRE	ÖHLDIHRING	RETENEDOR DE ACEITE	G04	7
800098219	VITE M8X95	SCREW M8X95	VIS M8X95	SCHRAUBE M8X95	TORNILLO M8X95	G01	4
800098304	TUBO REGOLATORE	REGULATOR PIPE	TUYAU REGULATEUR	REGLERLEITUNG	TUBO REGULADOR	G12	23
800098305	FILTRO POMPA BENZINA	FUEL PUMP FILTER	FILTRE POMPE A ESSENCE	BENZINPUMPENFILTER	FILTRO BOMBA GASOLINA	G12	13
800098321	PINZA INCLINATA MONTA FASCETTE CLIC	CLIC CLAMPS ASSEMBLY	PLIERS PINCE INCLINEE MONTAGE COLLIERS CLIC	GEBogene ZANGE SCHELLEN CLIC	MONTAGE PINZA INCLINADA PARA MONTAR ABRAZADERAS	J01	13
800098328	SPOILER PARAFANGO ANTERIORE	FRONT MUDGUARD SPOILER	SPOILER GARDE-BOUE AVANT	SPOILER VORDERER KOTFLÜGEL	SPOILER GUARDABARROS DELANTERO	E01	3
800098331	PIASTRA SX TELAIO	CHASSIS LH PLATE	PLAQUE G. CADRE	LINKE RAHMENPLATTE	PLACA IZQUIERDA BASTIDOR	A01	8
800098404	CUSCINETTO	BEARING	ROULEMENT	LAGER	COJINETE	G01	25
800098405	CUSCINETTO	BEARING	ROULEMENT	LAGER	COJINETE	G01	25
800098468	MOTORE COMPLETO	ENGINE ASSEMBLY	MOTEUR COMPLET	MOTOR KOMPLETT	MOTOR COMPLETO	G01	56
800098527	CANDELA NGK R 0045-J10	SPARK PLUG NGK R0045-J10	BOUGIE NGK R 0045-J10	ZÜNDKERZE NGK R0045-J10	BUJIA NGK R 0045-J10	G15	15
800098670	MOLLA ESTERNA VALVOLA	VALVE OUTER SPRING	RESSORT EXTERIEUR SOUPAPE	ÄUSSERE VENTILFEDER	MUELLE EXTERNO VALVULA	G04	10
						G04	25
800098671	MOLLA INTERNA VALVOLA	VALVE INNER SPRING	RESSORT INTERIEUR SOUPAPE	INNERE VENTILFEDER	MUELLE INTERNO VALVULA	G04	11
						G04	26
800098679	GUARNIZIONE TESTA (SP. 1.45)	HEAD GASKET (THICKNESS 1.45)	JOINT DE CULASSE (EP. 1.45)	ZYLINDERKOPFDICHTUNG (STÄRKE 1.45)	JUNTA CULATA (SP. 1.45)	G03	8
800098714	TUBO IN GOMMA	HOSE	DURIT	GUMMISCHLAUCH	TUBO DE GOMA	K02	4
800098715	TUBO IN GOMMA	HOSE	DURIT	GUMMISCHLAUCH	TUBO DE GOMA	K02	18
800098882	ALBERO PRIMARIO	MAIN SHAFT ASSEMBLY	ARBRE PRIMAIRE	HAUPTANTRIEBSWELLE	ARBOL PRIMARIO	G10	1
800098883	ALBERO SECONDARIO	TRANSMISSION SHAFT	ARBRE SECONDAIRE	VORGELEGEWELLE	ARBOL SECUNDARIO	G10	15
800098931	INGRANAGGIO (ASPIRAZIONE)	GEAR (INTAKE)	PIGNON (ADMISSION)	ZAHNRAD (EINLASS)	ENGRANAJE (ADMISION)	G05	7
800098935	CONDOTTO ASPIRAZIONE SX	LH INTAKE DUCT	CONDUIT D'ADMISSION G.	LINKER ANSAUGSTUTZEN	CONDUCTO DE ASPIRACION IZQ.	E02	5
800098936	CONDOTTO ASPIRAZIONE DX	RH INTAKE DUCT	CONDUIT D'ADMISSION D.	RECHTER ANSAUGSTUTZEN	CONDUCTO DE ASPIRACION DER.	E02	1
800098943	SERBATOIO ESPANSIONE	EXPANSION TANK	VASE D'EXPANSION	AUSDEHNUNGSGEFÄSS	TANQUE DE EXPANSION	G08	33
800098950	TUBO SCARICO SERBATOIO	FUEL TANK DRAINING PIPE	TUYAU VIDANGE RESERVOIR	ABLASSLEITUNG BENZINTANK	TUBO DESCARGA TANQUE	K02	17
800098952	TARGHETTA "EMISSIONI"	"EMISSIONS" DATA PLATE	PLAQUETTE "EMISSIONS"	SCHILD "ABGASWERTE"	ETIQUETA "EMISIONES"	K01	1
800098956	LIBRETTO USO E MANUTENZIONE (I)	USE AND MAINTENANCE HANDBOOK (I)	LIVRET UTILISATION ET ENTRETIEN (I)	BEDIENUNGSANLEITUNG (I)	MANUAL DE MANTENIMIENTO (I)	H01	5
800098957	CATALOGO RICAMBI	SPARE PARTS CATALOGUE	CATALOGUE PIECES DETACHEES	ERSATZTEILKATALOG	CATALOGO RECAMBIOS	H01	4
800098962	SEPARATORE	SEPARATOR	SEPARATEUR	TRENNVORRICHTUNG	SEPARADOR	D03	36
						D04	31
800098979	DECAL	DECAL	ADHESIF	AUFKLEBER	CALCOMANIA	E01	25
800098980	DECAL	DECAL	ADHESIF	AUFKLEBER	CALCOMANIA	E01	18
800098981	FIANCATA CARENA SX	LH SIDE FAIRING	FLANC DE CARENAGE G.	LINKES KAROSSERIE- SEITENTEIL	LATERAL CARENADO IZQUIERDO	E01	24
800098982	FIANCATA CARENA DX	RH SIDE FAIRING	FLANC DE CARENAGE D.	RECHTES KAROSSERIE- SEITENTEIL	LATERAL CARENADO DERECHO	E01	17
800099010	ATTREZZO PER FILTRO OLIO	OIL FILTER TOOL	OUTIL POUR FILTRE A HUILE	WERKZEUG FÜR ÖLFILTER	UTIL PARA FILTRO ACEITE	J03	23
800099041	MOTORE COMPLETO	ENGINE ASSEMBLY	MOTEUR COMPLET	MOTOR KOMPLETT	MOTOR COMPLETO	G01	56
800099064	RUOTA FONICA	PHONIC WHEEL	ROUE PHONIQUE	SENSOR RADDREHUNG	RUEDA FONICA	G10	35
						G17	36
800099105	COPERCHIO	COVER	COUVERCLE	DECKEL	TAPA	G01	39
800099112	CODONE	TAIL	COQUE ARRIERE	HECKTEIL	COLA	E04	12
800099113	DECAL	DECAL	ADHESIF	AUFKLEBER	CALCOMANIA	E04	15
800099165	CUPOLINO	DASHBOARD GUARD	TETE DE CARENAGE	SPORTSCHEIBE	PROTECCION	E01	8
800099167	DECAL	DECAL	ADHESIF	AUFKLEBER	CALCOMANIA	E01	9
800099341	PIASTRINA DI FISSAGGIO	FIXING PLATE	PLAQUETTE DE FIXATION	BEFESTIGUNGSBLECH	PLACA DE FIJACION	D02	42
800099383	GUARNIZIONE SCARICO	EXHAUST GASKET	JOINT D'ECHAPPEMENT	AUSPUFFDICHTUNG	EMPAQUE ESCAPE	G16	2

INDICE CODICI / DENOMINAZIONI

 CODEX / DESIGNATION INDEX • INDEX CODES / DÉNOMINATIONS
 INHALTSVERZEICHNIS CODE • ÍNDICE CÓDIGOS / DENOMINACIONES

Code	Denominazione	Description	Désignation	Bezeichnung	Descripción	Table	N°
800099394	RACCORDO COLLETTORI 1-2	EXHAUST PIPES 1-2 UNION	RACCORD D'ÉCHAPPEMENT 1-2	ANSCHLUSS AUSPUFF 1-2	RACOR ESCAPE 1-2	G16	28
800099395	RACCORDO COLLETTORI 3-4	EXHAUST PIPES 3-4 UNION	RACCORD D'ÉCHAPPEMENT 3-4	ANSCHLUSS AUSPUFF 3-4	RACOR ESCAPE 3-4	G16	29
800099396	COLLETTORE CENTRALE	CENTRAL MANIFOLD	COLLECTEUR CENTRAL	MITTLERER ABGASKRÜMMER	COLECTOR CENTRAL	G16	30
800099413	SEMIGUSCIO INFERIORE	LOWER HALF BEARING	DEMI-COQUE INFÉRIEURE	UNTERE SCHALENHÄLFTE	SEMICASCO INFERIOR	D03	7
800099416	COMANDO GAS COMPLETO	THROTTLE CONTROL ASSEMBLY	COMMANDE GAZ COMPLETE	GASGRIF KOMPLETT	MANDO GAS COMPLETO	D03	5
800099422	COLLETTORE USCITA CILINDRO 1	CYLINDER 1 OUTPUT MANIFOLD	COLLECTEUR ÉCHAPPEMENT CYLINDRE 1	ABGASKRÜMMER ZYLINDER 1	COLECTOR SALIDA CILINDRO 1	G16	24
800099423	COLLETTORE USCITA CILINDRO 2	CYLINDER 2 OUTPUT MANIFOLD	COLLECTEUR ÉCHAPPEMENT CYLINDRE 2	ABGASKRÜMMER ZYLINDER 2	COLECTOR SALIDA CILINDRO 2	G16	25
800099424	COLLETTORE USCITA CILINDRO 3	CYLINDER 3 OUTPUT MANIFOLD	COLLECTEUR ÉCHAPPEMENT CYLINDRE 3	ABGASKRÜMMER ZYLINDER 3	COLECTOR SALIDA CILINDRO 3	G16	26
800099425	COLLETTORE USCITA CILINDRO 4	CYLINDER 4 OUTPUT MANIFOLD	COLLECTEUR ÉCHAPPEMENT CYLINDRE 4	ABGASKRÜMMER ZYLINDER 4	COLECTOR SALIDA CILINDRO 4	G16	27
800099444	TARGHETTA "EMISSIONI"	"EMISSIONS" DATA PLATE	PLAQUETTE "EMISSIONS"	SCHILD "ABGASWERTE"	ETIQUETA "EMISIONES"	K01	1
800099459	VITE FISSAGGIO SCAMBIATORE OLIO	OIL COOLER FIXING SCREW	VIS DE FIXATION ÉCHANGEUR HUILE	ÖLTAUSCHER BEFESTIGUNGSSCHRAUBE	TORNILLO FIJACION CAMBIADOR DE ACEITE	G06	22
800099476	VITE M8X130	SCREW M8X130	VIS M8X130	SCHRAUBE M8X130	TORNILLO M8X130	G01	7
800099497	TESTA CILINDRI COMPLETA	CYLINDER HEAD ASSEMBLY	CULASSE COMPLETE	ZYLINDERKOPF KOMPLETT	CULATA COMPLETA	G04	1
800099521	DISCO FRIZIONE GUARNITO	LINED CLUTCH DISK	DISQUE GARNI	KUPPLUNGSSCHEIBE MIT BELAG	CUBO PORTADISCOS	G09	4
800099561	CANDELA NGK CR9EKB	SPARK PLUG NGK CR9EKB	BOUGIE NGK CR9EKB	ZÜNDKERZE NGK CR9EKB	BUJIA NGK CR9EKB	G15	15
8000A0120	CATENA DI DISTRIBUZIONE CHIUUSA	CLOSED TIMING CHAIN	CHAÎNE DISTRIBUTION FERMEE	VENTILSTEUERKETTE GESCHLOSSEN	CADENA DISTRIBUCION CERRADA	G05	6
8000A0370	CUSCINETTO	BEARING	ROULEMENT	LAGER	COJINETE	G17	6
						G17	11
						G17	18
						G17	24
						G17	29
8000A0619	BASAMENTO COMPLETO	ENGINE BLOCK ASSEMBLY	CARTER MOTEUR COMPLET	KURBELGEHÄUSE KOMPLETT	BASE COMPLETA	G01	1
8000A0696	CANDELA CHAMPION G 54 V	SPARK PLUG CHAMPION G 54 V	BOUGIE CHAMPION G 54 V	ZÜNDKERZE CHAMPION G 54 V	BUJIA CHAMPION G 54 V	G15	15
8000A0780	INGRANAGGIO (SCARICO)	GEAR (EXHAUST)	PIGNON (ÉCHAPPEMENT)	ZAHNRAD (AUSLASS)	ENGRANAJE (ESCAPE)	G05	8
8000A0781	ALBERO A CAMME (SCARICO)	CAMSHAFT (EXHAUST)	ARBRE A CAMES (ECH.)	NOCKENWELLE (AUSLASS)	ARBOL DE LEVAS (ESCAPE)	G05	4
8000A0817	ANELLO DI TENUTA	GROMMET	BAGUE D'ÉTANCHEITE	DICHTUNGSRING	RETEN	B06	27
						B07	27
8000A0826	ANELLO DI TENUTA	GROMMET	BAGUE D'ÉTANCHEITE	DICHTUNGSRING	RETEN	B06	5
						B07	5
8000A0841	VITE M12X30	SCREW M12X30	VIS M12X30	SCHRAUBE M12X30	TORNILLO M12X30	B06	1
						B07	1
8000A0901	ROSETTA	WASHER	RONDELLE	UNTERLEGSCHLEIBE	ARANDELA	G11	14
8000A0925	TARGHETTA "EMISSIONI"	"EMISSIONS" DATA PLATE	PLAQUETTE "EMISSIONS"	SCHILD "ABGASWERTE"	ETIQUETA "EMISIONES"	K01	1
8000A0956	TARGHETTA "EMISSIONI"	"EMISSIONS" DATA PLATE	PLAQUETTE "EMISSIONS"	SCHILD "ABGASWERTE"	ETIQUETA "EMISIONES"	K01	1
8000A0958	LIBRETTO USO E MANUTENZIONE (I)	USE AND MAINTENANCE HANDBOOK (I)	LIVRET UTILISATION ET ENTRETIEN (I)	BEDIENUNGSANLEITUNG (I)	MANUAL DE MANTENIMIENTO (I)	H01	5
8000A0960	LIBRETTO USO E MANUTENZIONE (I)	USE AND MAINTENANCE HANDBOOK (I)	LIVRET UTILISATION ET ENTRETIEN (I)	BEDIENUNGSANLEITUNG (I)	MANUAL DE MANTENIMIENTO (I)	H01	5
8000A0961	OWNER'S MANUAL (USA 50 STATI)	OWNER'S MANUAL (USA 50 STATES)	OWNER'S MANUAL (USA 50 ETATS)	OWNER'S MANUAL (USA 50 STAATEN)	OWNER'S MANUAL (USA 50 ESTADOS)	H01	5
8000A0962	AMMORTIZZATORE POST.	REAR SHOCK ABSORBER	AMORTISSEUR ARRIERE	HINTERER STOSSDÄMPFER	AMORTIGUADOR TRASERO	B02	17
8000A0964	TARGHETTA REGOLAZIONE CATENA	CHAIN ADJUSTMENT PLATE	PLAQUETTE REGLAGE CHAÎNE	SCHILD KETTENEINSTELLUNG	ETIQUETA REGULACION CADENA	B01	26
8000A0973	ROSETTA	WASHER	RONDELLE	UNTERLEGSCHLEIBE	ARANDELA	G17	5
						G17	10
8000A0975	ANELLO ELASTICO	SNAP RING	CIRCLIP	SPRENGRING	ARO	G17	8
						G17	40
8000A0980	ALBERO SECONDARIO	TRANSMISSION SHAFT	ARBRE SECONDAIRE	VORGELEGEWELLE	ARBOL SECUNDARIO	G17	17

INDICE CODICI / DENOMINAZIONI

CODEX / DESIGNATION INDEX • INDEX CODES / DÉNOMINATIONS

INHALTSVERZEICHNIS CODE • ÍNDICE CÓDIGOS / DENOMINACIONES

Code	Denominazione	Description	Désignation	Bezeichnung	Descripción	Table	N°
8000A0982	ROSETTA	WASHER	RONDELLE	UNTERLEGSCHIEBE	ARANDELA	G17	20
						G17	23
8000A0987	ROSETTA	WASHER	RONDELLE	UNTERLEGSCHIEBE	ARANDELA	G17	28
8000A0990	ANELLO ELASTICO	SNAP RING	CIRCLIP	SPRENGRING	ARO	G17	21
8000A1039	ATTREZZO PARAPOLVERE E PARAOLIO	DUST COVER AND OIL SEAL TOOL	OUTIL JOINT-POUSSIÈRE ET JOINT A LEVRE	WERKZEUG STAUBSCHUTZRINGE UND ÖLDICHRINGE ACEITE	UTIL GUARDAPOLVO Y RETEN DE	J01	17
8000A1072	ALBERO SECONDARIO	TRANSMISSION SHAFT	ARBRE SECONDAIRE	VORGELEGEWELLE	ARBOL SECUNDARIO	G17	17
8000A1086	CUSCINETTO	BEARING	ROULEMENT	LAGER	COJINETE	G11	4
8000A1087	CUSCINETTO	BEARING	ROULEMENT	LAGER	COJINETE	G01	30
8000A1234	ROSETTA	WASHER	RONDELLE	UNTERLEGSCHIEBE	ARANDELA	G17	39
8000A1238	DADO M8	NUT M8	ECROU M8	MUTTER M8	TUERCA M8	G16	10
8000A1239	MOLLA	SPRING	RESSORT	FEDER	MUELLE	G16	8
						G16	31
8000A1287	MOTORE COMPLETO	ENGINE ASSEMBLY	MOTEUR COMPLET	MOTOR KOMPLETT	MOTOR COMPLETO	G01	56
8000A1295	VITE PER SEPARATORE	SEPARATOR SCREW	VIS DE SEPARATEUR	SCHRAUBE FÜR TRENNVORRICHTUNG	TORNILLO PARA SEPARADOR	D03	37
						D04	32
8000A1340	TESTA CILINDRI COMPLETA	CYLINDER HEAD ASSEMBLY	CULASSE COMPLETE	ZYLINDERKOPF KOMPLETT	CULATA COMPLETA	G04	1
8000A1345	PISTONE COMPLETO	PISTON ASSEMBLY	PISTON COMPLET	KOLBEN KOMPLETT	PISTON COMPLETO	G03	2
8000A1348	ALBERO A CAMME (ASP.)	CAMSHAFT (INTAKE)	ARBRE A CAMES (ADM.)	NOCKENWELLE (EINLASS)	ARBOL DE LEVAS (ADM.)	G05	5
8000A1349	ALBERO A CAMME (SCARICO)	CAMSHAFT (EXHAUST)	ARBRE A CAMES (ECH.)	NOCKENWELLE (AUSLASS)	ARBOL DE LEVAS (ESCAPE)	G05	4
8000A1355	CORNETTO DI ASPIRAZIONE	INTAKE DUCT	CONE D'ADMISSION	ANSAUGSTUTZEN	TUBO DE ASPIRACION	G13	15
8000A1400	SONDA RISERVA CARBURANTE	LOW FUEL PROBE	SONDE DE RESERVE CARBURANT	BENZINSTANDGEBER RESERVE	CAPTADOR RESERVA COMBUSTIBLE	G12	7
8000A1432	ATTREZZO MONTAGGIO PISTONI	PISTON ASSEMBLY TOOL	OUTIL MONTAGE PISTONS	WERKZEUG KOLBENMONTAGE	UTIL MONTAJE DEL PISTON	J03	24
8000A1438	DECAL	DECAL	ADHESIF	AUFKLEBER	CALCOMANIA	E04	15
						E05	20
8000A1440	KIT INIETTORE	INJECTOR KIT	KIT INJECTEUR	UMBAUSATZ EINSPRITZDÜSE	KIT INYECTOR	G13	11
8000A1442	KIT COLLETTORE BENZINA	FEED MANIFOLD KIT	KIT COLLECTEUR D'ESSENCE	UMBAUSATZ VERSORGUNGSSTUTZEN	KIT COLECTOR DE GASOLINA	G13	16
8000A1450	KIT SENSORE FARFALLA	THROTTLE VALVE SENSOR KIT	KIT CAPTEUR DE PAPILLON	UMBAUSATZ DROSSELKLAPPESENSOR	KIT SENSOR DE VALVULA DE MARIPOSA	G13	12
8000A1453	STAFFA BOWDEN	BOWDEN BRACKET	BRIDE BOWDEN	BOWDEN BEFESTIGUNG	BRIDA BOWDEN	G13	25
8000A1455	KIT VITE REGOLAZIONE	ADJUSTMENT SCREW KIT	KIT VIS DE REGLAGE	UMBAUSATZ EINSTELLUNGSSCHRAUBE	KIT TORNILLO DE REGULACION	G13	27
8000A1486	AMMORTIZZATORE POST.	REAR SHOCK ABSORBER	AMORTISSEUR ARRIERE	HINTERER STOSSDÄMPFER	AMORTIGUADOR TRASERO	B02	17
8000A1488	FASCETTA CON VITE	CLAMP WITH SCREW	COLLIER AVEC VIS	SHELLE MIT SCHRAUBE	CINTA CON TORNILLO	G06	32
8000A1494	CODONE	TAIL	COQUE ARRIERE	HECKTEIL	COLA	E04	12
8000A1495	CODONE	TAIL	COQUE ARRIERE	HECKTEIL	COLA	E05	16
8000A1520	KIT DECAL	DECAL KIT	ADHESIF KIT	UMBAUSATZ AUFKLEBER	KIT CALCOMANIA	E04	15
						E05	20
8000A1529	LIBRETTO USO E MANUTENZIONE (I)	USE AND MAINTENANCE HANDBOOK (I)	LIVRET UTILISATION ET ENTRETIEN (I)	BEDIENUNGSANLEITUNG (I)	MANUAL DE MANTENIMIENTO (I)	H01	5
8000A1544	PIASTRINA PER SCAMBIATORE	PLATE FOR OIL COOLER	PLAQUETTE DE ECHANGEUR HUILE	BLECH FÜR ÖLTAUSCHER	PLACA PARA CAMBIADOR DE ACEITE	G06	21
8000A1556	AMMORTIZZATORE POST.	REAR SHOCK ABSORBER	AMORTISSEUR ARRIERE	HINTERER STOSSDÄMPFER	AMORTIGUADOR TRASERO	B02	17
8000A1558	TUBO MANDATA BENZINA	FUEL DELIVERY PIPE	CANALISATION REFOULEMENT ESSENCE	BENZIN-ZULEITUNG	TUBO ENVIO GASOLINA	G13	9
8000A1792	FASCETTA METALLICA	METAL CLAMP	COLLIER METALLIQUE	METALLSHELLE	CINTA METALICA	G08	18
8000A1825	FLANGIA PORTATARGA/ CATADIOTTRI	NUMBER PLATE HOLDER/ RETROREFLECTORS FLANGE	FLASQUE SUPPORT DE PLAQUE/REFLECTEURS	BEFESTIGUNGSFLANSCH NUMMERN SCHILDBEFESTI- GUNG/KATZENAUGE	BRIDA PORTAPLACA/ CATAFARROS	K01	10
8000A1839	BICCHIERINO PER VALVOLA	VALVE CUP	GODET POUR SOUPAPE	VENTILBECHER	TAZA PARA VALVULA	G05	20

INDICE CODICI / DENOMINAZIONI

 CODEX / DESIGNATION INDEX • INDEX CODES / DÉNOMINATIONS
 INHALTSVERZEICHNIS CODE • ÍNDICE CÓDIGOS / DENOMINACIONES

Code	Denominazione	Description	Désignation	Bezeichnung	Descripción	Table	N°
8000A1859	GRUPPO VITE DI REGOLAZIONE	ADJUSTING SCREW SET	GROUPE VIS DE REGLAGE	EINSTELLSCHRAUBE EINHEIT	GRUPO TORNILLO DE REGULACIÓN	B06	7
						B07	7
8000A1860	BOCCOLA	BUSH	BAGUE	HÜLSE	CASQUILLO	B06	8
						B07	8
8000A1863	PARAPOLVERE	DUST COVER	JOINT-POUSSIÈRE	STAUBSCHUTZRING	GUARDAPOLVO	B06	19
						B07	19
8000A1864	PIEDINO DX COMPLETO	RH FOOT ASSEMBLY	BASE D. COMPLETE	RECHTER FUSS KOMPLETT	PIE' DERECHO COMPLETO	B06	20
8000A1865	PIEDINO SX COMPLETO	LH FOOT ASSEMBLY	BASE G. COMPLETE	LINKER FUSS KOMPLETT	PIE' IZQUIERDO COMPLETO	B07	20
8000A1867	ROSETTA	WASHER	RONDELLE	UNTERLEGSCHEIBE	ARANDELA	B06	23
						B07	23
8000A1868	DISTANZIALE	SPACER	ENTRETOISE	ABSTANDHALTER	DISTANCIADOR	B06	24
						B07	24
8000A1869	FODERO	SLEEVE	FOURREAU	HÜLSE	ENVOLTURA	B06	25
						B07	25
8000A1870	ANELLO DI TENUTA	GROMMET	BAGUE D'ÉTANCHEITE	DICHTUNGSRING	RETEN	B06	26
						B07	26
8000A1871	TAPPO COMPLETO	PLUG ASSEMBLY	BOUCHON COMPLET	VERSCHLUSS KOMPLETT	TAPON COMPLETO	B06	28
						B07	28
8000A1872	DECAL	DECAL	ADHESIF	AUFKLEBER	CALCOMANIA	B06	29
						B07	29
8000A1940	MOLLA ESTERNA VALVOLA	VALVE OUTER SPRING	RESSORT EXTERIEUR SOUPAPE	ÄUSSERE VENTILFEDER	MUELLE EXTERNO VALVOLA	G04	10
8000A1941	MOLLA INTERNA VALVOLA	VALVE INNER SPRING	RESSORT INTERIEUR SOUPAPE	INNERE VENTILFEDER	MUELLE INTERNO VALVOLA	G04	11
8000A1953	PERNO PER ALBERO DI CENTRAGGIO	PIN FOR CENTERING	AXE POUR ARBRE	BOLZEN FÜR	PERNO PARA EJE	J01	15
		SHAFT	DE CENTRAGE	ZENTRIERWELLE	DE CENTRAJE		
8000A2180	ANELLO DI TENUTA	GROMMET	BAGUE D'ÉTANCHEITE	DICHTUNGSRING	RETEN	D03	42
8000A2181	ANELLO DI TENUTA	GROMMET	BAGUE D'ÉTANCHEITE	DICHTUNGSRING	RETEN	D03	41
8000A2216	CARTUCCIA	CARTRIDGE	CARTOUCHE	PATRONE	CARTUCHO	B06	15
						B07	15
8000A2217	ASSIEME PACCO COMPRESSIONE	COMPRESSION PACK ASSEMBLY	ENSEMBLE PAQUET COMPRESSION	BAUGRUPPE KOMPRESSIONSPAKET	CONJUNTO PAQUETE COMPRESION	B06	18
						B07	18
8000A2218	DISTANZIALE E BOCCOLA	SPACER AND BUSH	ENTRETOISE ET BAGUE	ABSTANDHALTER UND HÜLSE	DISTANCIADOR Y CASQUILLO	B06	21
						B07	21
8000A2219	MOLLA	SPRING	RESSORT	FEDER	MUELLE	B06	22
						B07	22
8000A2280	ATTREZZO CHIUSURA CATENA DISTRIBUZIONE	TIMING CHAIN	OUTIL MONTAGE	WERKZEUG VENTIL-	UTIL MONTAJE CADENA	J03	20
		MOUNTING TOOL	CHAÎNE DISTRIBUTION	STEUERKETTENBAU	DE LA DISTRIBUCION		
8000A2281	ATTREZZO APERTURA CATENA DISTRIBUZIONE	TIMING CHAIN	OUTIL COUPE	WERKZEUG VENTIL-	UTIL CORTE CADENA	J03	21
		CUTTING TOOL	CHAÎNE DISTRIBUTION	STEUERKETTENSCHNITT	DE LA DISTRIBUCION		
8000A2306	GUIDA VALVOLA COMPLETO	VALVE GUIDE ASSEMBLY	GUIDE DE SOUPAPE COMPLETE	VENTILFÜHRUNG KOMPLETT	GUIA VALVOLA COMPLETA	G04	27
8000A2318	CUSCINETTO	BEARING	ROULEMENT	LAGER	COJINETE	G11	3
8000A2319	DISTANZIALE	SPACER	ENTRETOISE	ABSTANDHALTER	DISTANCIADOR	G17	33
8000A2363	CAVI TELERUTTORE BATTERIA	BATTERY ELECTROMAGNETIC	CABLES TELERUPTEUR	KABEL BATTERIE-	CABLES TELERRUPTOR	F04	8
		SWITCH CABLES	BATTERIE	FERNRELAIS	BATERIA		
8000A2365	CODONE	TAIL	COQUE ARRIERE	HECKTEIL	COLA	E04	12
8000A2366	DECAL	DECAL	ADHESIF	AUFKLEBER	CALCOMANIA	E04	15
						E05	20
8000A2367	CODONE	TAIL	COQUE ARRIERE	HECKTEIL	COLA	E05	16
8000A2385	TAMPONE MONTAGGIO GUIDA	GUIDE ASSEMBLY PAD	TAMPON MONTAGE GUIDE	PUFFER MONTAGE FÜHRUNG	TAPON MONTAJE GUIAS	J03	18
8000A2392	DECAL	DECAL	ADHESIF	AUFKLEBER	CALCOMANIA	E01	34
8000A2393	DECAL	DECAL	ADHESIF	AUFKLEBER	CALCOMANIA	E01	35
8000A2394	DECAL	DECAL	ADHESIF	AUFKLEBER	CALCOMANIA	F01	27
8000A2395	DECAL	DECAL	ADHESIF	AUFKLEBER	CALCOMANIA	E04	34
8000A2396	DECAL	DECAL	ADHESIF	AUFKLEBER	CALCOMANIA	E04	33

INDICE CODICI / DENOMINAZIONI

CODEX / DESIGNATION INDEX • INDEX CODES / DÉNOMINATIONS

INHALTSVERZEICHNIS CODE • ÍNDICE CÓDIGOS / DENOMINACIONES

Code	Denominazione	Description	Désignation	Bezeichnung	Descripción	Table	N°
8000A2397	DECAL	DECAL	ADHESIF	AUFKLEBER	CALCOMANIA	E01	36
8000A2398	FIANCATA CARENA DX	RH FAIRING SIDE	FLANC DE CARENAGE D.	RECHTES KAROSSERIE-SEITENTEIL	LATERAL CARENADO DERECHO	E01	17
8000A2399	FIANCATA CARENA SX	LH FAIRING SIDE	FLANC DE CARENAGE G.	LINKES KAROSSERIE-SEITENTEIL	LATERAL CARENADO IZQUIERDO	E01	24
8000A2400	CUPOLINO	DASHBOARD GUARD	TETE DE CARENAGE	SPORTSCHEIBE	PROTECCION	E01	8
8000A2401	RETROVISORE SX CON INDICATORE	LH REARVIEW MIRROR WITH TURN INDICATOR	RETROVISEUR G. AVEC INDICATEUR	LINKER RÜCKSPIEGEL MIT BLINKER	RETROVISOR IZQUIERDO CON INDICADOR	F01	14
8000A2402	RETROVISORE DX CON INDICATORE	RH REARVIEW MIRROR WITH TURN INDICATOR	RETROVISEUR D. AVEC INDICATEUR	RECHTER RÜCKSPIEGEL MIT BLINKER	RETROVISOR DERECHO CON INDICADOR	F01	5
8000A2462	CRUSCOTTO COMPLETO	DASHBOARD ASSEMBLY	COMBINE DE BORD COMPLET	ARMATURENBRETT KOMPLETT	TABLERO COMPLETO	F02	9
8000A2533	LIBRETTO USO E MANUTENZIONE (I)	USE AND MAINTENANCE HANDBOOK (I)	LIVRET UTILISATION ET ENTRETIEN (I)	BEDIENUNGSANLEITUNG (I)	MANUAL DE MANTENIMIENTO (I)	H01	5
8000A2534	OWNER'S MANUAL (USA 50 STATI)	OWNER'S MANUAL (USA 50 STATES)	OWNER'S MANUAL (USA 50 ETATS)	OWNER'S MANUAL (USA 50 STAATEN)	OWNER'S MANUAL (USA 50 ESTADOS)	H01	5
8000A2591	INGRANAGGIO (ASPIRAZIONE)	GEAR (INTAKE)	PIGNON (ADMISSION)	ZAHNRAD (EINLASS)	ENGRANAJE (ADMISION)	G05	7
8000A2592	INGRANAGGIO (SCARICO)	GEAR (EXHAUST)	PIGNON (ECHAPPEMENT)	ZAHNRAD (AUSLASS)	ENGRANAJE (ESCAPE)	G05	8
8000A2625	BROCCIA PER GUIDA VALVOLE	BROACH FOR VALVE GUIDE	BROCHE POUR GUIDE DE SOUPAPE	VENTILFÜHRUNGSRÄUMEN	MANDRIL PARA GUIA VALVOLA	J03	22
8000A2628	ALBERO PRIMARIO COMPLETO	MAIN SHAFT ASSEMBLY	ARBRE PRIMAIRE COMPLET	HAUPTANTRIEBSWELLE KOMPLETT	ARBOL PRIMARIO COMPLETO	G17	1
8000A2629	ALBERO PRIMARIO	MAIN SHAFT ASSEMBLY	ARBRE PRIMAIRE	HAUPTANTRIEBSWELLE	ARBOL PRIMARIO	G17	2
8000A2630	INGRANAGGIO 5°	5TH GEAR	PIGNON 5°	ZAHNRAD 5. GANG	ENGRANAJE 5°	G17	7
8000A2631	INGRANAGGIO 3°-4°	3RD-4TH GEAR	PIGNON 3°-4°	ZAHNRAD 3.-4. GANG	ENGRANAJE 3°-4°	G17	9
8000A2632	INGRANAGGIO 6°	6TH GEAR	PIGNON 6°	ZAHNRAD 6. GANG	ENGRANAJE 6°	G17	12
8000A2633	INGRANAGGIO 2°	2ND GEAR	PIGNON 2°	ZAHNRAD 2. GANG	ENGRANAJE 2°	G17	13
8000A2634	ALBERO SECONDARIO COMPLETO	TRANSMISSION SHAFT ASSEMBLY	ARBRE SECONDAIRE COMPLET	VORGELEGEWELLE KOMPLETT	ARBOL SECUNDARIO COMPLETO	G17	16
8000A2635	INGRANAGGIO 2°	2ND GEAR	PIGNON 2°	ZAHNRAD 2. GANG	ENGRANAJE 2°	G17	19
8000A2636	INGRANAGGIO 6°	6TH GEAR	PIGNON 6°	ZAHNRAD 6. GANG	ENGRANAJE 6°	G17	22
8000A2637	INGRANAGGIO 3°	3RD GEAR	PIGNON 3°	ZAHNRAD 3. GANG	ENGRANAJE 3°	G17	25
8000A2638	INGRANAGGIO 4°	4TH GEAR	PIGNON 4°	ZAHNRAD 4. GANG	ENGRANAJE 4°	G17	26
8000A2639	INGRANAGGIO 5°	5TH GEAR	PIGNON 5°	ZAHNRAD 5. GANG	ENGRANAJE 5°	G17	27
8000A2640	INGRANAGGIO 1°	1ST GEAR	PIGNON 1°	ZAHNRAD 1. GANG	ENGRANAJE 1°	G17	30
8000A2644	ALBERO PRIMARIO	MAIN SHAFT ASSEMBLY	ARBRE PRIMAIRE	HAUPTANTRIEBSWELLE	ARBOL PRIMARIO	G17	2
8000A2645	INGRANAGGIO 2°	2ND GEAR	PIGNON 2°	ZAHNRAD 2. GANG	ENGRANAJE 2°	G17	13
8000A2650	INGRANAGGIO 2°	2ND GEAR	PIGNON 2°	ZAHNRAD 2. GANG	ENGRANAJE 2°	G17	19
8000A2734	DECAL	DECAL	ADHESIF	AUFKLEBER	CALCOMANIA	B01	35
8000A2753	TARGHETTA REGOLAZIONE CATENA	CHAIN ADJUSTMENT PLATE	PLAQUETTE REGLAGE CHAINE	SCHILD KETTENEINSTELLUNG	ETIQUETA REGULACION CADENA	B01	26
8000A2762	TERMORIFLETTENTE	THERMOREFLECTOR	THERMOREFLECTEUR	HITZESCHUTZ	TERMOREVERBERANTE	F06	25
8000A3026	BIELLA COMPLETA	CONNECTING ROD ASSEMBLY	BIELLE COMPLETE	PLEUEL KOMPLETT	BIELA COMPLETA	G02	3
8000A3056	TARGHETTA "EMISSIONI"	"EMISSIONS" DATA PLATE	PLAQUETTE "EMISSIONS"	SCHILD "ABGASWERTE"	ETIQUETA "EMISIONES"	K01	1
8000A3065	LIBRETTO USO E MANUTENZIONE (I)	USE AND MAINTENANCE HANDBOOK (I)	LIVRET UTILISATION ET ENTRETIEN (I)	BEDIENUNGSANLEITUNG (I)	MANUAL DE MANTENIMIENTO (I)	H01	5
8000A3081	MAGLIA GIUNZIONE CATENA	CHAIN LINK	MAILLON DE JONCTION CHAINE	KETTENSCHLOSS	ESLABON UNION CADENA	C01	2
8000A3098	CD-ROM MANUALE OFFICINA MOTOTELAIO	CHASSIS OVERHAUL HANDBOOK CD-ROM	CD-ROM MANUEL MECANIQUE GENERALE	WERKSTATTHANDBUCH MOTORRADRAHMEN CD-ROM	CD-ROM MANUAL PARA TALLERES VEHICULO	H01	10
8000A3099	CD-ROM MANUALE OFFICINA MOTORE	ENGINE OVERHAUL HANDBOOK CD-ROM	CD-ROM MANUEL D'ATELIER MOTEUR	WERKSTATTHANDBUCH MOTOR CD-ROM	CD-ROM MANUAL PARA TALLERES MOTOR	H01	11
8000A3226	ANTIVIBRANTE	VIBRATION-DAMPER	ANTI-VIBRATIONS	SCHWINGUNGSDÄMPFER	ANTIVIBRANTE	A02 A03	12 12
8000A3227	BATTERIA	BATTERY	BATTERIE	BATTERIE	BATERIA	F06	22
8000A3281	ANELLO DI TENUTA	GROMMET	BAGUE D'ETANCHEITE	DICHTUNGSRING	RETEN	G06	33
8000A3381	MOTORE COMPLETO	ENGINE ASSEMBLY	MOTEUR COMPLET	MOTOR KOMPLETT	MOTOR COMPLETO	G01	56

INDICE CODICI / DENOMINAZIONI

 CODEX / DESIGNATION INDEX • INDEX CODES / DÉNOMINATIONS
 INHALTSVERZEICHNIS CODE • ÍNDICE CÓDIGOS / DENOMINACIONES

Code	Denominazione	Description	Désignation	Bezeichnung	Descripción	Table	N°
8000A3385	TESTA CILINDRI COMPLETA	CYLINDER HEAD ASSEMBLY	CULASSE COMPLETE	ZYLINDERKOPF KOMPLETT	CULATA COMPLETA	G04	1
8000A3406	ATTREZZO MISURA SPORGENZA PISTONI	PISTON PROJECTION MEASURING TOOL	OUTIL MESURE DEPASSEMENT PISTONS	WERKZEUG ZUM MESSEN KOLBENÜBERSTAND	UTIL PARA MEDIR SOBRESALIDA DEL PISTON	J03	7
8000A3474	ROSETTA	WASHER	RONDELLE	UNTERLEGSCHIEBE	ARANDELA	A01	37
8000A3486	ROSETTA	WASHER	RONDELLE	UNTERLEGSCHIEBE	ARANDELA	G05	22
8000A3522	ALBERO PRIMARIO COMPLETO	MAIN SHAFT ASSEMBLY	ARBRE PRIMAIRE COMPLET	HAUPTANTRIEBSWELLE KOMPLETT	ARBOL PRIMARIO COMPLETO	G17	1
8000A3523	ALBERO SECONDARIO COMPLETO	TRANSMISSION SHAFT ASSEMBLY	ARBRE SECONDAIRE COMPLET	VORGELEGEWELLE KOMPLETT	ARBOL SECUNDARIO COMPLETO	G17	16
8000A3524	INGRANAGGIO 6°	6TH GEAR	PIGNON 6°	ZAHNRAD 6. GANG	ENGRANAJE 6°	G17	12
8000A3551	PIASTRA PORTAPINZA	CALIPER PLATE	SUPPORT D'ETRIER	BREMSSATTELHALTER	PLACA PORTAPINZA	C01	14
8000A3702	KIT FILTRO OLIO	OIL FILTER KIT	KIT FILTRE A HUILE	UMBAUSATZ ÖLFILTER	KIT FILTRO DE ACEITE	G06	31
8000A3732	SCODELLINO SUPERIORE	UPPER CAP	COUPELLE SUPERIEURE	OBERER FEDERTELLER	TEJUELO SUPERIOR	G04	12
8000A3733	PIATTELLO INFERIORE	LOWER CAP	COUPELLE INFERIEURE	UNTERER FEDERTELLER	ASIENTO INFERIOR	G04	13
8000A3749	CENTRALINA INIEZIONE	INJECTION POWER UNIT	BOITIER DE CONTROLE INJECTION	EINSPRITZ-STEUERUNG	CENTRALITA INECCION	F06	13
8000A3751	EPROM	EPROM	EPROM	EPROM	EPROM	F06	14
8000A3754	CUSCINETTO	BEARING	ROULEMENT	LAGER	COJINETE	G11	3
8000A3812	PARASTRAPPI ALTERNATORE	ALTERNATOR SPRING DRIVE	FLECTEUR ALTERNATEUR	REISSSCHUTZ LICHTMASCHINE	ACOPLAMIENTO FLEXIBLE ALTERNADOR	G14	8
8000A3823	LEVA FRENO ANTERIORE	FRONT BRAKE LEVER	LEVIER DE FREIN AVANT	VORDERRADBREMSEHEBEL	PALANCA FRENO DELANTERO	D03	43
8000A3920	LIBRETTO USO E MANUTENZIONE (I)	USE AND MAINTENANCE HANDBOOK (I)	LIVRET UTILISATION ET ENTRETIEN (I)	BEDIENUNGSANLEITUNG (I)	MANUAL DE MANTENIMIENTO (I)	H01	5
8000A3921	OWNER'S MANUAL (USA 50 STATI)	OWNER'S MANUAL (USA 50 STATES)	OWNER'S MANUAL (USA 50 ETATS)	OWNER'S MANUAL (USA 50 STAATEN)	OWNER'S MANUAL (USA 50 ESTADOS)	H01	5
8000A3935	COPRICATENA INFERIORE	LOWER CHAIN COVER	CARTER DE CHAINE INFERIEUR	UNTERER KETTENSCHUTZ	CUBRECADENA INFERIOR	B01	25
8000A4196	ROSETTA	WASHER	RONDELLE	UNTERLEGSCHIEBE	ARANDELA	G17	20
						G17	23
8000A4301	INGRANAGGIO (ASPIRAZIONE)	GEAR (INTAKE)	PIGNON (ADMISSION)	ZAHNRAD (EINLASS)	ENGRANAJE (ADMISION)	G05	7
8000A4302	INGRANAGGIO (SCARICO)	GEAR (EXHAUST)	PIGNON (ECHAPPEMENT)	ZAHNRAD (AUSLASS)	ENGRANAJE (ESCAPE)	G05	8
8000A4317	ATTREZZO PER FILTRO OLIO	OIL FILTER TOOL	OUTIL POUR FILTRE A HUILE	WERKZEUG FÜR ÖLFILTER	UTIL PARA FILTRO ACEITE	J03	23
8000A4508	REGISTRO	REGISTER	ECROU DE REGLAGE	EINSTELLVORRICHTUNG	REGULADOR	B02	3
8000A4686	ATTREZZATURA CONTROLLO CO	CO CONTROL TOOL ASSEMBLY	OUTIL CONTROLE DU CO	CO-KONTROLLE- HALTERUNG	UTIL CONTROL CO	J03	25
8000A4827	CORPO FARFALLATO	THROTTLE BODY	CORPS DE PAPILLON	DROSSELKÖRPER	CUERPO CON VALVULA DE MARIPOSA	G13	10
8000A9983	VETRINO CUPOLINO	DASHBOARD GUARD GLASS	BULLE	SPORTSCHEIBENGLAS	VIDRIO PROTECCION	E01	11
8000A9987	VETRINO CUPOLINO	DASHBOARD GUARD GLASS	BULLE	SPORTSCHEIBENGLAS	VIDRIO PROTECCION	E01	11
8000B2143	MOZZO ECCENTRICO	ECCENTRIC HUB	MOYEU DECENTRE	EXZENTERNABE	CUBO EXCENTRICO	C01	4
8000B2149	DISTANZIALE	PACER	ENTRETOISE	ABSTANDHALTER	DISTANCIADOR	C01	6
8000B3392	PERNO RUOTA POSTERIORE	REAR WHEEL PIN	AXE ROUE ARRIERE	HINTERRADACHSE	PERNO RUEDA TRASERA	C01	7
8000B3584	PIASTRINA AGGANCIO MOLLA SPRING FIXING BRACKET	HUB-PIN-SPACER KIT	PLAQUETTE D'ACCROCHEMENT DU RESSORT	PLÄTTCHEN FEDERANLENKUNG	PLACA FIJACION MUELLE	A01	22
8000B3986	MOLLA INTERNA	INNER SPRING	RESSORT INT.	INNENFEDER	MUELLE INT.	A01	39
8000B3987	MOLLA ESTERNA	OUTER SPRING	RESSORT EXT.	AUSSENFEDER	MUELLE EXT.	A01	38
8000B4782	PIASTRA	PLATE	PLAQUE	PLATTE	PLACA	A01	18
8000B4954	KIT MOZZO- PERNO- DISTANZIALE	HUB-PIN-SPACER KIT	KIT MOYEU-AXE- ENTRETOISE	BAUSATZ NABE-ACHSE- ABSTANDHALTER	KIT CUBO-PERNO- DISTANCIADOR	C01	37
8000B4955	DISTANZIALE	SPACER	ENTRETOISE	ABSTANDHALTER	DISTANCIADOR	C01	31
80A026970	VITE M5X16	SCREW M5X16	VIS M5X16	SCHRAUBE M5X16	TORNILLO M5X16	E04	8
						E05	8
80A047053	VITE M4X8	SCREW M4X8	VIS M4X8	SCHRAUBE M4X8	TORNILLO M4X8	A02	23
						A03	25
80A053546	PERNO PEDANA	FOOTBOARD PIN	AXE DE CALE-PIED	FUSSRASTENBOLZEN	PERNO ESTRIBO	A03	28
						D01	23
						D02	41

INDICE CODICI / DENOMINAZIONI

CODEX / DESIGNATION INDEX • INDEX CODES / DÉNOMINATIONS

INHALTSVERZEICHNIS CODE • ÍNDICE CÓDIGOS / DENOMINACIONES

Code	Denominazione	Description	Désignation	Bezeichnung	Descripción	Table	N°
80A053548	PERNO LEVA FRENO POSTERIORE	REAR BRAKE LEVER PIN	AXE LEVIER FREIN ARRIERE	BOLZEN BREMSPEDALHEBEL HINTERRADBREMSE	PERNO PALANCA FRENO TRASERO	D02	27
80A055757	FORCELLA POMPA FRENO POSTERIORE	REAR BRAKE PUMP FORK	FOURCHETTE MAITRE-CYL. FREIN ARRIERE	GABEL BREMSPUMPE HINTERRADBREMSE	HORQUILLA BOMBA FRENO TRASERO	D02	25
80A065535	VITE M5X14	SCREW M5X14	VIS M5X14	SCHRAUBE M5X14	TORNILLO M5X14	F06	7
80A081478	CILINDRO COMANDO FRIZIONE	CLUTCH CONTROL CYLINDER	CYLINDRE RECEPTEUR DEBRAYAGE	KUPPLUNGZYLINDER	CILINDRO ACCIONAMIENTO EMBRAGUE	G09	13
80A081584	FORCELLA INNESTO MARCE	SHIFTING FORK	FOURCHETTE DE SELECTION	SCHALTGABEL	HORQUILLA ENGRANE MARCHA	G11	17
80A084882	TELAIO	CHASSIS	CADRE	RAHMEN	BASTIDOR	A01	1
80A084901	SPINA	PIN	GOUJON	STIFT	PERNO	C01	8
80A086728	COPERCHIO	COVER	COUVERCLE	DECKEL	TAPA	G01	46
80A089782	CONTRAPPESO	COUNTERWEIGHT	CONTREPOIDS	GEGENGEWICHT	CONTRAPESO	D03 D04	15 5
80A090246	SUPPORTO SPECCHIO DX	RH MIRROR SUPPORT	SUPPORT DE RETROVISEUR D.	RECHTE RÜCKSPIEGEL- HALTERUNG	SOPORTE ESPEJO DERECHO	F01	1
80A090247	SUPPORTO SPECCHIO SX	LH MIRROR SUPPORT	SUPPORT DE RETROVISEUR G.	LINKE RÜCKSPIEGELHALTERUNG	SOPORTE ESPEJO IZQUIERDO	F01	2
80A090257	FIANCHETTO SX AIRBOX	AIRBOX LH SIDE CACHE G.	AIRBOX LINKES	AIRBOX-SEITENTEIL	LATERAL IZQUIERDO AIRBOX	E02	9
80A090258	FIANCHETTO DX AIRBOX	AIRBOX RH SIDE CACHE D.	AIRBOX RECHTES	AIRBOX-SEITENTEIL	LATERAL DERECHO AIRBOX	E02	10
80A090297	FIANCHETTO SX SERBATOIO	FUEL TANK LH SIDE	CACHE G. RESERVOIR	LINKE TANK- SEITENVERKLEIDUNG	LATERAL IZQUIERDO DEPOSITO	E03	5
80A090298	FIANCHETTO DX SERBATOIO	FUEL TANK RH SIDE	CACHE D. RESERVOIR	RECHTE TANK- SEITENVERKLEIDUNG	LATERAL DERECHO DEPOSITO	E03	3
80A090317	DECAL	DECAL	ADHESIF	AUFKLEBER	CALCOMANIA	E01	25
80A090318	DECAL	DECAL	ADHESIF	AUFKLEBER	CALCOMANIA	E01	18
80A090319	DECAL	DECAL	ADHESIF	AUFKLEBER	CALCOMANIA	E01	19 26
80A090321	DECAL	DECAL	ADHESIF	AUFKLEBER	CALCOMANIA	E02	17
80A090370	RETROVISORE DX CON INDICATORE	RH REARVIEW MIRROR WITH TURN INDICATOR	RETROVISEUR D. AVEC INDICATEUR	RECHTER RÜCKSPIEGEL MIT BLINKER	RETROVISOR DERECHO CON INDICADOR	F01	5
80A090371	RETROVISORE SX CON INDICATORE	LH REARVIEW MIRROR WITH TURN	RETROVISEUR G. AVEC INDICATEUR	LINKER RÜCKSPIEGEL MIT BLINKER	RETROVISOR IZQUIERDO CON INDICADOR	F01	14
80A090379	SELLA PILOTA	DRIVER'S SADDLE	SELLE PILOTE	FAHRERSITZ	SILLIN PILOTO	E04	24
80A090412	COPRI IMPIANTO ELETTRICO DX	RH ELECTRICAL EQUIPMENT COVER	CACHE EQUIPEMENT ELECTRIQUE D.	RECHTE ABDECKUNG ELEKTRISCHE ANLAGE	CUBRE INSTALACION ELECTRICA DERECHA	E02	13
80A090413	COPRI IMPIANTO ELETTRICO SX	LH ELECTRICAL EQUIPMENT COVER	CACHE EQUIPEMENT ELECTRIQUE G.	LINKE ABDECKUNG ELEKTRISCHE ANLAGE	CUBRE INSTALACION ELECTRICA IZQUIERDA	E02	14
80A090925	TERMINALE DI INNESTO	COUPLER	RACCORD	VERBINDUNGSTEIL	TERMINAL DE CONEXION	G12	4
80A091659	SUPPORTO PEDANA ANTERIORE SX	LH FRONT FOOTBOARD SUPPORT	SUPPORT DE CALE-PIED AVANT G.	HALTERUNG VORDERE LINKE FUSSRASTE	SOPORTE ESTRIBO DELANTERO IZQUIERDO	D01	21
80A091660	SUPPORTO PEDANA DX	RH FOOTBOARD SUPPORT	SUPPORT DE CALE-PIED D.	HALTERUNG RECHTE FUSSRASTE	SOPORTE ESTRIBO DERECHO	D02	39
80A091661	PEDANA SX	LH FOOTBOARD	CALE-PIED G.	LINKE FUSSRASTE	ESTRIBO IZQUIERDO	A03 D01	30 22
80A091662	PEDANA DX	RH FOOTBOARD	CALE-PIED D.	RECHTE FUSSRASTE	ESTRIBO DERECHO	A03 D02	35 40
80A091667	CUPOLINO	DASHBOARD GUARD	TETE DE CARENAGE	SPORTSCHEIBE	PROTECCION	E01	8
80A091668	FIANCATA CARENA DX	RH FAIRING SIDE	FLANC DE CARENAGE D.	RECHTES KAROSSERIE- SEITENTEIL	LATERAL CARENADO DERECHO	E01	17
80A091669	FIANCATA CARENA SX	LH FAIRING SIDE	FLANC DE CARENAGE G.	LINKES KAROSSERIE- SEITENTEIL	LATERAL CARENADO IZQUIERDO	E01	24
80A091673	SERBATOIO BENZINA	FUEL TANK	RESERVOIR D'ESSENCE	BENZINTANK	DEPOSITO GASOLINA	E03	6
80A091674	AIRBOX	AIRBOX	AIRBOX	AIRBOX	AIRBOX	E02	16
80A091680	PROTEZIONE SCARICO	EXHAUST PROTECTION	PROTECTION ECHAPPEMENT	AUSPUFFVERKLEIDUNG	PROTECCION ESCAPE	G16	22

INDICE CODICI / DENOMINAZIONI

 CODEX / DESIGNATION INDEX • INDEX CODES / DÉNOMINATIONS
 INHALTSVERZEICHNIS CODE • ÍNDICE CÓDIGOS / DENOMINACIONES

Code	Denominazione	Description	Désignation	Bezeichnung	Descripción	Table	N°
80A092272	SOTTOCARENA	UNDERFAIRING	SABOT DE CARENAGE	KAROSSERIE-UNTERTEIL	CARENADO INFERIOR	E01	29
80A092494	COPERCHIO CATENA	CHAIN COVER	COUVERCLE DE CHAINE	KETTENSCHUTZ	TAPA CADENA	G11	41
80A092671	COPRICATENA SUPERIORE	UPPER CHAIN COVER	CARTER DE CHAINE SUPERIEUR	OBERER KETTENSCHUTZ	CUBRECADENA SUPERIOR	B01	22
80A092845	GAMBA SX COMPLETA	LH LEG ASSEMBLY	BRAS G. COMPLET	LINKES BEIN KOMPLETT	PATA HORQUILLA IZQUIERDA COMPLETA	B03	2
80A092846	GAMBA DX COMPLETA	RH LEG ASSEMBLY	BRAS D. COMPLET	RECHTES BEIN KOMPLETT	PATA HORQUILLA DERECHA COMPLETA	B03	1
80A092892	SEMIMANUBRIO DX	RH HALF HANDLEBAR	DEMI-GUIDON D.	RECHTE LENKERHÄLFTE	SEMIMANILLAR DERECHA	D03	1
80A092893	SEMIMANUBRIO SX	LH HALF HANDLEBAR	DEMI-GUIDON G.	LINKE LENKERHÄLFTE	SEMIMANILLAR IZQUIERDA	D04	1
80A093322	COPRI INTERRUPTORE ACCENSIONE	IGNITION LOCK SWITCH COVER	CACHE CONTACTEUR D'ALLUMAGE	ZÜNDSCHLOSS- ABDECKUNG	CUBRE INTERRUPTOR DE ENCENDIDO	A01	27
80A093359	STELO SX COMPLETO	LH STEM ASSEMBLY	TUBE G. COMPLET	LINKER SCHAFT KOMPLETT	VASTAGO IZQ. COMPLETO	B05	1
80A093360	STELO DX COMPLETO	RH STEM ASSEMBLY	TUBE D. COMPLET	RECHTER SCHAFT KOMPLETT	VASTAGO DER. COMPLETO	B04	1
80A093403	STELO CON PIEDINO SX	STEM WITH LH FOOT	TUBE AVEC BASE G.	LINKER SCHAFT MIT FUSS	VASTAGO CON PIE' IZQ.	B05	2
80A093404	STELO CON PIEDINO DX	STEM WITH RH FOOT	TUBE AVEC BASE D.	RECHTER SCHAFT MIT FUSS	VASTAGO CON PIE' DER.	B04	2
80A094168	SUPPORTO PEDANA POSTERIORE DX	RH REAR FOOTBOARD SUPPORT	SUPPORT DE CALE-PIED ARRIERE D.	HALTERUNG HINTERE RECHTE FUSSRASTE	SOPORTE ESTRIBO TRASERO DERECHO	A03	34
80A094169	SUPPORTO PEDANA POSTERIORE SX	LH REAR FOOTBOARD SUPPORT	SUPPORT DE CALE-PIED ARRIERE G.	HALTERUNG HINTERE LINKE FUSSRASTE	SOPORTE ESTRIBO TRASERO IZQUIERDO	A03	27
80A094176	SELLA PASSEGGERO	PILLION	SELLE PASSAGER	BEIFAHRSITZ	SILLIN PASAJERO	E05	27
80A094632	CERCHIO RUOTA ANTERIORE	FRONT RIM	JANTE ROUE AVANT	VORDERRADFELGE	LLANTA RUEDA DELANTERA	C02	1
80A095845	SILENZIATORI DI SCARICO	SILENCERS	SILENCIEUX D'ECHAPPEMENT	SCHÄLLDAMPFER	SILENCIADOR DE ESCAPE	G16	15
80A098726	GAMBA DX COMPLETA	RH LEG ASSEMBLY	BRAS D. COMPLET	RECHTES BEIN KOMPLETT	PATA HORQUILLA DERECHA COMPLETA	B03	1
80A098727	GAMBA SX COMPLETA	LH LEG ASSEMBLY	BRAS G. COMPLET	LINKES BEIN KOMPLETT	PATA HORQUILLA IZQUIERDA COMPLETA	B03	2
80A098944	CODONE	TAIL	COQUE ARRIERE	HECKTEIL	COLA	E04	12
80A0A0963	COPRICATENA INFERIORE	LOWER CHAIN COVER	CARTER DE CHAINE INFERIEUR	UNTERER KETTENSCHUTZ	CUBRECADENA INFERIOR	B01	25
80A0A1558	TUBO RITORNO BENZINA	FUEL RETURN PIPE	CANALISATION DE RETOUR ESSENCE	BENZIN-RÜCKLEITUNG	TUBO RETORNO GASOLINA	G13	7
80A0A1857	STELO SX COMPLETO	LH STEM ASSEMBLY	TUBE G. COMPLET	LINKER SCHAFT KOMPLETT	VASTAGO IZQ. COMPLETO	B07	4
80A0A1858	STELO DX COMPLETO	RH STEM ASSEMBLY	TUBE D. COMPLET	RECHTER SCHAFT KOMPLETT	VASTAGO DER. COMPLETO	B06	4
80A0A2754	COPRICATENA INFERIORE	LOWER CHAIN COVER	CARTER DE CHAINE INFERIEUR	UNTERER KETTENSCHUTZ	CUBRECADENA INFERIOR	B01	25
80A0A3055	PARAFANGO ANTERIORE	FRONT MUDGUARD	GARDE-BOUE AVANT	VORDERER KOTFLÜGEL	GUARDABARROS DELANTERO	E01	1
80A0A4000	TARGHETTA PNEUMATICI	TYRES DATA PLATE	PLAQUETTE PNEUMATIQUES	SCHILD REIFEN	ETIQUETA NEUMATICOS	E01	12
80A0B3583	CAVALLETTO LATERALE	SIDE STAND	BEQUILLE LATERALE	SEITENSTÄNDER	CABALLETE LATERAL	A01	19
80A0B4792	KIT CAVALLETTO LATERALE	SIDE STAND KIT	KIT BEQUILLE LATERALE	BAUSATZ STÄNDER	KIT CABALLETE LATERAL	A01	40
80B043928	DADO M8	NUT M8	ECROU M8	MUTTER M8	TUERCA M8	A02	9
						A03	9
						G16	10
						K02	10
80B073832	CATADIOTTRO	RETROREFLECTOR	REFLECTEUR	KATZENAUGE	CATAFARO	K01	11
80B084882	TELAIO	CHASSIS	CADRE	RAHMEN	BASTIDOR	A01	1
80B090254	PARAFANGO ANTERIORE	FRONT MUDGUARD	GARDE-BOUE AVANT	VORDERER KOTFLÜGEL	GUARDABARROS DELANTERO	E01	1
80B090297	FIANCHETTO SX SERBATOIO	FUEL TANK LH SIDE	CACHE G. RESERVOIR	LINKE TANKVERKLEIDUNG	LATERAL IZQUIERDO DEPOSITO	E03	5
80B090298	FIANCHETTO DX SERBATOIO	FUEL TANK RH SIDE	CACHE D. RESERVOIR	RECHTE TANKVERKLEIDUNG	LATERAL DERECHO DEPOSITO	E03	3
80B090321	DECAL	DECAL	ADHESIF	AUFKLEBER	CALCOMANIA	E02	17
80B090370	RETROVISORE DX CON INDICATORE	RH REARVIEW MIRROR WITH TURN INDICATOR	RETROVISEUR D. AVEC INDICATEUR	RECHTER RÜCKSPIEGEL MIT BLINKER	RETROVISOR DERECHO CON INDICADOR	F01	5
80B090371	RETROVISORE SX CON INDICATORE	LH REARVIEW MIRROR WITH TURN INDICATOR	RETROVISEUR G. AVEC INDICATEUR	LINKER RÜCKSPIEGEL MIT BLINKER	RETROVISOR IZQUIERDO CON INDICADOR	F01	14
80B091667	CUPOLINO	DASHBOARD GUARD	TETE DE CARENAGE	SPORTSCHEIBE	PROTECCION	E01	8

INDICE CODICI / DENOMINAZIONI

CODEX / DESIGNATION INDEX • INDEX CODES / DÉNOMINATIONS

INHALTSVERZEICHNIS CODE • ÍNDICE CÓDIGOS / DENOMINACIONES

Code	Denominazione	Description	Désignation	Bezeichnung	Descripción	Table	N°
80B091668	FIANCATA CARENA DX	RH FAIRING SIDE	FLANC DE CARENAGE D.	RECHTES KAROSSERIE-SEITENTEIL	LATERAL CARENADO DERECHO	E01	17
80B091669	FIANCATA CARENA SX	LH FAIRING SIDE	FLANC DE CARENAGE G.	LINKES KAROSSERIE-SEITENTEIL	LATERAL CARENADO IZQUIERDO	E01	24
80B091672	CODONE	TAIL	COQUE ARRIERE	HECKTEIL	COLA	E04	12
80B091673	SERBATOIO BENZINA	FUEL TANK	RESERVOIR D'ESSENCE	BENZINTANK	DEPOSITO GASOLINA	E03	6
80B091674	AIRBOX	AIRBOX	AIRBOX	AIRBOX	AIRBOX	E02	16
80B092272	SOTTOCARENA	UNDERFAIRING	SABOT DE CARENAGE	KAROSSERIE-UNTERTEIL	CARENADO INFERIOR	E01	29
80B094176	SELLA PASSEGGERO	PILLION	SELLE PASSAGER	BEIFAHRERSITZ	SILLIN PASAJERO	E05	27
80B094632	CERCHIO RUOTA ANTERIORE	FRONT RIM	JANTE ROUE AVANT	VORDERRADFELGE	LLANTA RUEDA DELANTERA	C02	1
80B095845	SILENZIATORI DI SCARICO	SILENCERS	SILENCIEUX D'ECHAPPEMENT	SCHALLDÄMPFER	SILENCIADOR DE ESCAPE	G16	15
80B0A1494	CODONE	TAIL	COQUE ARRIERE	HECKTEIL	COLA	E04	12
80B0A1495	CODONE	TAIL	COQUE ARRIERE	HECKTEIL	COLA	E05	16
80B0A2365	CODONE	TAIL	COQUE ARRIERE	HECKTEIL	COLA	E04	12
80B0A2367	CODONE	TAIL	COQUE ARRIERE	HECKTEIL	COLA	E05	16
80C090297	FIANCHETTO SX SERBATOIO	FUEL TANK LH SIDE	CACHE G. RESERVOIR	LINKE TANKVERKLEIDUNG	LATERAL IZQ. DEPOSITO	E03	5
80C090298	FIANCHETTO DX SERBATOIO	FUEL TANK RH SIDE	CACHE D. RESERVOIR	RECHTE TANKVERKLEIDUNG	LATERAL DER. DEPOSITO	E03	3
80C090370	RETROVISORE DX CON INDICATORE	RH REARVIEW MIRROR WITH TURN INDICATOR	RETROVISOR D. AVEC INDICATEUR	RECHTER RÜCKSPIEGEL MIT BLINKER	RETROVISOR DERECHO CON INDICADOR	F01	5
80C090371	RETROVISORE SX CON INDICATORE	LH REARVIEW MIRROR WITH TURN INDICATOR	RETROVISOR G. AVEC INDICATEUR	LINKER RÜCKSPIEGEL MIT BLINKER	RETROVISOR IZQUIERDO CON INDICADOR	F01	14
80C091673	SERBATOIO BENZINA	FUEL TANK	RESERVOIR D'ESSENCE	BENZINTANK	TANQUE GASOLINA	E03	6
80C091674	AIRBOX	AIRBOX	AIRBOX	AIRBOX	AIRBOX	E02	16
80C092272	SOTTOCARENA	UNDERFAIRING	SABOT DE CARENAGE	KAROSSERIE-UNTERTEIL	CARENADO INFERIOR	E01	29
80D090297	FIANCHETTO SX SERBATOIO	FUEL TANK LH SIDE	CACHE G. RESERVOIR	LINKE TANKVERKLEIDUNG	LATERAL IZQ. DEPOSITO	E03	5
80D090298	FIANCHETTO DX SERBATOIO	FUEL TANK RH SIDE	CACHE D. RESERVOIR	RECHTE TANKVERKLEIDUNG	LATERAL DER. DEPOSITO	E03	3
80D0A3055	PARAFANGO ANTERIORE	FRONT MUDGUARD	GARDE-BOUE AVANT	VORDERER KOTFLÜGEL	GUARDABARROS DELANTERO	E01	1
80E0A3055	PARAFANGO ANTERIORE	FRONT MUDGUARD	GARDE-BOUE AVANT	VORDERER KOTFLÜGEL	GUARDABARROS DELANTERO	E01	1
8A0018246	LAMPADA	BULB	AMPOULE	LAMPE	LAMPARA	F07	3
8A0021774	CUSCINETTO	BEARING	ROULEMENT	LAGER	COJINETE	G11	13
8A0023116	ANELLO DI TENUTA	GROMMET	BAGUE D'ETANCHEITE	DICHTUNGSRING	RETEN	K02	9
8A0023120	ANELLO DI TENUTA	GROMMET	BAGUE D'ETANCHEITE	DICHTUNGSRING	RETEN	G01	45
8A0025044	CUSCINETTO	BEARING	ROULEMENT	LAGER	COJINETE	G10	10
						G17	11
						G17	29
8A0025082	ANELLO DI TENUTA	GROMMET	BAGUE D'ETANCHEITE	DICHTUNGSRING	RETEN	G04	20
8A0028855	ANELLO DI TENUTA	GROMMET	BAGUE D'ETANCHEITE	DICHTUNGSRING	RETEN	G07	3
						G11	37
8A0031106	ANELLO DI TENUTA	GROMMET	BAGUE D'ETANCHEITE	DICHTUNGSRING	RETEN	G01	33
8A0036022	ROSETTA	WASHER	RONDELLE	UNTERLEGSCHIEBE	ARANDELA	G11	12
8A0051549	BOCCOLA	BUSH	PION	BUCHSE	CASQUILLO	G01	13
8A0066531	VITE M5X25	SCREW M5X25	VIS M5X25	SCHRAUBE M5X25	TORNILLO M5X25	D05	6
8A0067545	VITE M6X35	SCREW M6X35	VIS M6X35	SCHRAUBE M6X35	TORNILLO M6X35	D02	33
						G01	5
						G07	20
8A0070266	TUBO SERBATOIO/ POMPA FRENO	FUEL TANK/BRAKE PUMP PIPE	CANALISATION RESERVOIR/ MAITRE-CYLINDRE	LEITUNG BREMSFLÜSSIGKEITS- BEHÄLTER/ BREMSPUMPE	TUBO TANQUE/ BOMBA FRENO	D02	22
8A0081221	CAPPUCCIO CANDELA	SPARK PLUG CAP	CAPUCHON BOUGIE	KERZENSTECKER	CAPUCHON BUJIA	G15	14
8A0081228	GUIDA VALVOLA	VALVE GUIDE	GUIDE DE SOUPAPE	VENTILFÜHRUNG	GUIA VALVULA	G04	3
8A0081315	SEMICUSCINETTO DI BIELLA (BLU)	BIG END HALF BEARING (BLUE)	DEMI-COUSSINET DI BIELLE (BLEU)	PLEUELGERHÄLFTE (BLAU)	SEMICOJINETE DE BIELA (AZUL)	G02	5
8A0081316	SEMICUSCINETTO DI BANCO (BLU)	CRANKSHAFT HALF BEARING (BLUE)	DEMI-COUSSINET DE PALIER (BLU)	KURBELWELLEN- LAGERHÄLFTE (BLAU)	SEMICOJINETE PRINCIPAL (AZUL)	G01	17
8A0081317	SEMICUSCINETTO DI BANCO (BLU)	CRANKSHAFT HALF BEARING (BLUE)	DEMI-COUSSINET DE PALIER (BLU)	KURBELWELLEN- LAGERHÄLFTE (BLAU)	SEMICOJINETE PRINCIPAL (AZUL)	G01	16

INDICE CODICI / DENOMINAZIONI

 CODEX / DESIGNATION INDEX • INDEX CODES / DÉNOMINATIONS
 INHALTSVERZEICHNIS CODE • ÍNDICE CÓDIGOS / DENOMINACIONES

Code	Denominazione	Description	Désignation	Bezeichnung	Descripción	Table	N°
8A0081387	ALTERNATORE	ALTERNATOR	ALTERNATEUR	LICHTMASCHINE	ALTERNADOR	G15	1
8A0081466	DISTANZIALE	SPACER	ENTRETOISE	ABSTANDHALTER	DISTANCIADOR	G10 G17	32 33
8A0081584	FORCELLA INNESTO MARCE	SHIFTING FORK	FOURCHETTE DE SELECTION	SCHALTGABEL	HORQUILLA ENGRANE MARCHA	G11	17
8A0082759	DISCO FRENO ANTERIORE	FRONT BRAKE DISK	DISQUE FREIN AV.	BREMSSSCHEIBE VORDERRADBREMSE	DISCO FRENO DELANTERO	C02	5
8A0084182	PASTIGLIA REGOLAZIONE GIOCO (SP.1.65)	CLEARANCE ADJUSTING PAD (THICKNESS 1.65)	PASTILLE DE CALAGE (EP.1.65)	EINSTELLPLÄTTCHEN VENTILSPIEL (STÄRKE 1.65)	PASTILLA REGULACION JUEGO (SP.1.65)	G05	21
8A0084857	BUSSOLA FISSAGGIO MOTORE	ENGINE FIXING BUSH	BAGUE ANCRAGE MOTEUR	MOTOR- BEFESTIGUNGSBUCHSE	BUJE FIJACION MOTOR	A01	13
8A0084924	CORONA	GEAR	COURONNE	ZAHNKRANZ	CORONA	C01	28
8A0084926	CORONA	GEAR	COURONNE	ZAHNKRANZ	CORONA	C01	28
8A0089306	VITE BIELLA AMMORTIZZATORE STERZO	STEERING DAMPER SUPPORT SCREW	VIS BIELLETTE AMORTISSEUR DE DIRECTION	SCHRAUBE LENKUNGSDÄMPFER	TORNILLO BIELLA AMORTIGUADOR DIRECCION	B08	13
8A0089416	ALBERO COMANDO FORCELLE	FORK CONTROL SHAFT	BARILLET DE SELECTION	STEUERWELLE SCHALTGABELN	EJE ACCIONAMIENTO HORQUILLA	G11	11
8A0089628	TARGHETTA CENTRALINA	POWER UNIT DATA PLATE	PLAQUETTE DE BOITIER DE CONTROLE	SCHILD FÜR STEUERUNG	ETIQUETA PARA CENTRALITA	F06	21
8A0089786	VITE M6X12	SCREW M6X12	VIS M6X12	SCHRAUBE M6X12	TORNILLO M6X12	B01	24
8A0090282	TESTA DI STERZO	STEERING HEAD	TETE SUPERIEUR DIRECTION	LENKKOPF	CABEZA TUBO DIRECCION	B03	12
8A0090320	DECAL	DECAL	ADHESIF	AUFKLEBER	CALCOMANIA	E04 E05	13 17
8A0090360	COLLETTORE USCITA CILINDRI 1-2	CYLINDERS 1-2 OUTPUT MANIFOLD	COLLECTEUR ECH. CYLINDRES 1-2	ABGASKRÜMMER ZYLINDER 1-2	COLACTOR SALIDA CILINDROS 1-2	G16	3
8A0090361	COLLETTORE USCITA CILINDRI 3-4	CYLINDERS 3-4 OUTPUT MANIFOLD	COLLECTEUR ECH. CYLINDRES 3-4	ABGASKRÜMMER ZYLINDER 3-4	COLECTOR SALIDA CILINDROS 3-4	G16	4
8A0090362	COLLETTORE CENTRALE	CENTRAL MANIFOLD	COLLECTEUR CENTRAL	MITTLERER ABGASKRÜMMER	COLECTOR CENTRAL	G16	5
8A0090901	VITE M4X13,7	SCREW M4X13,7	VIS M4X13,7	SCHRAUBE M4X13,7	TORNILLO M4X13,7	B01 E01 E02	28 14 12
8A0090904	VITE M5X14	SCREW M5X14	VIS M5X14	SCHRAUBE M5X14	TORNILLO M5X14	E04 E05	17 31
8A0090940	TUBO IN GOMMA	HOSE	DURIT	GUMMISCHLAUCH	TUBO DE GOMA	K02	7
8A0090944	BOCCHETTONE	FILLER	EMBOUT	STUTZEN	BOCA DE RELLENO	G08	35
8A0091025	FASCETTA CLIC R	CLIC R CLAMP	COLLIER CLIC R	SHELLE CLIC R	ABRAZADERA CLIC R	G08	63
8A0091037	TUBO IN GOMMA	HOSE	DURIT	GUMMISCHLAUCH	TUBO DE GOMA	G13 K02	24 23
8A0091634	FASCETTA A MOLLA	SPRING CLAMP	COLLIER A RESSORT	FEDERSHELLE	CINTA ELASTICA	G13 K02	6 19
8A0091696	PORTALAMPADA	LAMP HOLDER	DOUILLE D'AMPOULE	LAMPENHALTERUNG	PORTALAMPARA	F07	4
8A0091697	VITE M8X60	SCREW M8X60	VIS M8X60	SCHRAUBE M8X60	TORNILLO M8X60	G01	8
8A0092256	FASCETTA CLIC R	CLIC R CLAMP	COLLIER CLIC R	SHELLE CLIC R	ABRAZADERA	K02 K02	11 14
8A0092663	TAMPONE	PAD	TAMPON	PUFFER	TAPON	E02	19
8A0093346	VITE M3X10	SCREW M3X10	VIS M3X10	SCHRAUBE M3X10	TORNILLO M3X10	F01	17
8A0094018	TARGHETTA "RUMORE"	"NOISE" DATA PLATE	PLAQUETTE "BRUIT"	SCHILD "GERÄUSCHBELASTUNG"	ETIQUETA "RUIDOS"	K01	2
8A0095427	EPROM	EPROM	EPROM	EPROM	EPROM	F06	14
8A0095500	TAMPONE	PAD	TAMPON	PUFFER	TAPON	F07	23
8A0096565	ROSETTA	WASHER	RONDELLE	UNTERLEGSSCHEIBE	ARANDELA	G17	39
8A0097109	TUBO RADIATORE/POMPA	COOLER/PUMP PIPE	CANALISATION RADIATEUR/ POMPE	LEITUNG KÜHLER/PUMPE	TUBO RADIADOR/BOMBA	G08	53
8A0097739	TAMBURO SELETTOR MARCE	GEARS SELECTING DRUM	TAMBOUR DE SELECTION	GANGWAHLTROMMEL	TAMBOR SELECTOR MARCHA	G11	20
8A0098679	GUARNIZIONE TESTA (SP. 1.3)	HEAD GASKET (THICKNESS 1.3)	JOINT DE CULASSE (EP. 1.3)	ZYLINDERKOPFDICHTUNG (STÄRKE 1.3)	JUNTA CULATA (SP. 1.3)	G03	8

INDICE CODICI / DENOMINAZIONI

CODEX / DESIGNATION INDEX • INDEX CODES / DÉNOMINATIONS

INHALTSVERZEICHNIS CODE • ÍNDICE CÓDIGOS / DENOMINACIONES

Code	Denominazione	Description	Désignation	Bezeichnung	Descripción	Table	N°
8A0098946	OWNER'S MANUAL (USA 49 STATI)	OWNER'S MANUAL (USA 49 STATES)	OWNER'S MANUAL (USA 49 ETATS)	OWNER'S MANUAL (USA 49 STAATEN)	OWNER'S MANUAL (USA 49 ESTADOS)	H01	5
8A0098956	LIBRETTO USO E MANUTENZIONE (GB)	USE AND MAINTENANCE HANDBOOK (GB)	LIVRET UTILISATION ET ENTRETIEN (GB)	BEDIENUNGSANLEITUNG (GB)	MANUAL DE MANTENIMIENTO (GB)	H01	5
8A0098958	OWNER'S MANUAL (USA 49 STATI)	OWNER'S MANUAL (USA 49 STATES)	OWNER'S MANUAL (USA 49 ETATS)	OWNER'S MANUAL (USA 49 STAATEN)	OWNER'S MANUAL (USA 49 ESTADOS)	H01	5
8A0099394	RACCORDO COLLETTORI 1-2	EXHAUST PIPES 1-2 UNION	RACCORD D'ÉCHAPPEMENT 1-2	ANSCHLUSS AUSPUFF 1-2	RACOR ESCAPE 1-2	G16	28
8A0099395	RACCORDO COLLETTORI 3-4	EXHAUST PIPES 3-4 UNION	RACCORD D'ÉCHAPPEMENT 3-4	ANSCHLUSS AUSPUFF 3-4	RACOR ESCAPE 3-4	G16	29
8A0099396	COLLETTORE CENTRALE	CENTRAL MANIFOLD	COLLECTEUR CENTRAL	MITTLERER ABGASKRÜMMER	COLECTOR CENTRAL	G16	30
8A0099422	COLLETTORE USCITA CILINDRO 1	CYLINDER 1 OUTPUT MANIFOLD	COLLECTEUR ÉCHAPPEMENT CYLINDRE 1	ABGASKRÜMMER ZYLINDER 1	COLECTOR SALIDA CILINDRO 1	G16	24
8A0099423	COLLETTORE USCITA CILINDRO 2	CYLINDER 2 OUTPUT MANIFOLD	COLLECTEUR ÉCHAPPEMENT CYLINDRE 2	ABGASKRÜMMER ZYLINDER 2	COLECTOR SALIDA CILINDRO 2	G16	25
8A0099424	COLLETTORE USCITA CILINDRO 3	CYLINDER 3 OUTPUT MANIFOLD	COLLECTEUR ÉCHAPPEMENT CYLINDRE 3	ABGASKRÜMMER ZYLINDER 3	COLECTOR SALIDA CILINDRO 3	G16	26
8A0099425	COLLETTORE USCITA CILINDRO 4	CYLINDER 4 OUTPUT MANIFOLD	COLLECTEUR ÉCHAPPEMENT CYLINDRE 4	ABGASKRÜMMER ZYLINDER 4	COLECTOR SALIDA CILINDRO 4	G16	27
8A00A0958	LIBRETTO USO E MANUTENZIONE (GB)	USE AND MAINTENANCE HANDBOOK (GB)	LIVRET UTILISATION ET ENTRETIEN (GB)	BEDIENUNGSANLEITUNG (GB)	MANUAL DE MANTENIMIENTO (GB)	H01	5
8A00A0960	LIBRETTO USO E MANUTENZIONE (GB)	USE AND MAINTENANCE HANDBOOK (GB)	LIVRET UTILISATION ET ENTRETIEN (GB)	BEDIENUNGSANLEITUNG (GB)	MANUAL DE MANTENIMIENTO (GB)	H01	5
8A00A1234	ROSETTA	WASHER	RONDELLE	UNTERLEGSCHIEBE	ARANDELA	G17	39
8A00A1529	LIBRETTO USO E MANUTENZIONE (GB)	USE AND MAINTENANCE HANDBOOK (GB)	LIVRET UTILISATION ET ENTRETIEN (GB)	BEDIENUNGSANLEITUNG (GB)	MANUAL DE MANTENIMIENTO (GB)	H01	5
8A00A1530	OWNER'S MANUAL (USA 49 STATI)	OWNER'S MANUAL (USA 49 STATES)	OWNER'S MANUAL (USA 49 ETATS)	OWNER'S MANUAL (USA 49 STAATEN)	OWNER'S MANUAL (USA 49 ESTADOS)	H01	5
8A00A2306	GUIDA VALVOLA COMPLETO	VALVE GUIDE ASSEMBLY	GUIDE DE SOUPAPE COMPLETE	VENTILFÜHRUNG KOMPLETT	GUIA VALVULA COMPLETA	G04	27
8A00A2533	LIBRETTO USO E MANUTENZIONE (GB)	USE AND MAINTENANCE HANDBOOK (GB)	LIVRET UTILISATION ET ENTRETIEN (GB)	BEDIENUNGSANLEITUNG (GB)	MANUAL DE MANTENIMIENTO (GB)	H01	5
8A00A3048	COLLETTORE USCITA CILINDRI 1-2	CYLINDERS 1-2 OUTPUT MANIFOLD	COLLECTEUR ECH. CYLINDRES 1-2	ABGASKRÜMMER ZYLINDER 1-2	COLACTOR SALIDA CILINDROS 1-2	G16	3
8A00A3049	COLLETTORE USCITA CILINDRI 3-4	CYLINDERS 3-4 OUTPUT MANIFOLD	COLLECTEUR ECH. CYLINDRES 3-4	ABGASKRÜMMER ZYLINDER 3-4	COLECTOR SALIDA CILINDROS 3-4	G16	4
8A00A3050	COLLETTORE CENTRALE CON CATALIZZATORE	CENTRAL MANIFOLD WITH CATALYST	COLLECTEUR CENTRAL AVEC CATALYSEUR	MITTLERER ABGASKRÜMMER MIT KATALYSATOR	COLECTOR CENTRAL CON CATALIZADOR	G16	5
8A00A3065	LIBRETTO USO E MANUTENZIONE (GB)	USE AND MAINTENANCE HANDBOOK (GB)	LIVRET UTILISATION ET ENTRETIEN (GB)	BEDIENUNGSANLEITUNG (GB)	MANUAL DE MANTENIMIENTO (GB)	H01	5
8A00A3080	CATENA	CHAIN	CHAINE	KETTE	CADENA	C01	35
8A00A3749	CENTRALINA INIEZIONE (F)	INJECTION POWER UNIT (F)	BOITIER DE CONTROLE INJECTION (F)	EINSPRITZ-STEUERUNG (F)	CENTRALITA INYECCION (F)	F06	13
8A00A3751	EPROM (F)	EPROM (F)	EPROM (F)	EPROM (F)	EPROM (F)	F06	14
8A00A3920	LIBRETTO USO E MANUTENZIONE (GB)	USE AND MAINTENANCE HANDBOOK (GB)	LIVRET UTILISATION ET ENTRETIEN (GB)	BEDIENUNGSANLEITUNG (GB)	MANUAL DE MANTENIMIENTO (GB)	H01	5
8AA059572	VITE M5X12	SCREW M5X12	VIS M5X12	SCHRAUBE M5X12	TORNILLO M5X12	E04 E05 F07	27 26 11
8AA084924	CORONA	GEAR	COURONNE	ZAHNKRANZ	CORONA	C01	28
8AA090246	SUPPORTO SPECCHIO DX	RH MIRROR SUPPORT	SUPPORT DE RETROVISEUR D.	RECHTE RÜCKSPIEGEL- HALTERUNG	SOPORTE ESPEJO DERECHO	F01	1
8AA090247	SUPPORTO SPECCHIO SX	LH MIRROR SUPPORT	SUPPORT DE RETROVISEUR G.	LINKE RÜCKSPIEGELHALTERUNG	SOPORTE ESPEJO IZQUIERDO	F01	2
8AA090381	TAMPONE POSTERIORE SELLA	SADDLE REAR PAD	TAMPON ARRIERE SELLE	HINTERER SITZBANKPUFFER	TAPON TRASERO SILLIN	E04	28
8AA090431	PERNO	PIN	AXE	ZAPFEN	PERNO	A01	20
8AA090983	CERCHIO RUOTA POSTERIORE	REAR RIM	JANTE ROUE ARRIERE	HINTERRADFELGE	LLANTA RUEDA TRASERA	C01	1
8AA091672	CODONE	TAIL	COQUE ARRIERE	HECKTEIL	COLA	E04	12
8AA094173	CODONE	TAIL	COQUE ARRIERE	HECKTEIL	COLA	E05	16

INDICE CODICI / DENOMINAZIONI

 CODEX / DESIGNATION INDEX • INDEX CODES / DÉNOMINATIONS
 INHALTSVERZEICHNIS CODE • ÍNDICE CÓDIGOS / DENOMINACIONES

Code	Denominazione	Description	Désignation	Bezeichnung	Descripción	Table	N°
8AA0A1494	CODONE	TAIL	COQUE ARRIERE	HECKTEIL	COLA	E04	12
8AA0A1495	CODONE	TAIL	COQUE ARRIERE	HECKTEIL	COLA	E05	16
8AA0A2365	CODONE	TAIL	COQUE ARRIERE	HECKTEIL	COLA	E04	12
8AA0A2367	CODONE	TAIL	COQUE ARRIERE	HECKTEIL	COLA	E05	16
8AB090983	CERCHIO RUOTA POSTERIORE	REAR RIM	JANTE ROUE ARRIERE	HINTERRADFELGE	LLANTA RUEDA TRASERA	C01	1
8AC090983	CERCHIO RUOTA POSTERIORE	REAR RIM	JANTE ROUE ARRIERE	HINTERRADFELGE	LLANTA RUEDA TRASERA	C01	1
8B0036022	ROSETTA	WASHER	RONDELLE	UNTERLEGSCHEIBE	ARANDELA	G11	12
8B0057196	TAPPO	PLUG	BOUCHON	VERSCHLUSS	TAPON	G05	23
8B0066778	VITE AUTOFILETTANTE	TAPPING SCREW	VIS TARAUD	BLECHSCHRAUBE	TORNILLO		
	3,9X9,5	3,9X9,5	3,9X9,5	3,9X9,5	AUTORROSCANTE 3,9X9,5	G08	39
8B0067545	VITE M6X55	SCREW M6X55	VIS M6X55	SCHRAUBE M6X55	TORNILLO M6X55	G01	6
						G01	54
8B0069056	VITE M8X15	SCREW M8X15	VIS M8X15	SCHRAUBE M8X15	TORNILLO M8X15	D02	44
8B0070695	TAPPO	PLUG	BOUCHON	VERSCHLUSS	TAPON	A01	25
8B0081228	GUIDA VALVOLA	VALVE GUIDE	GUIDE DE SOUPAPE	VENTILFÜHRUNG	GUIA VALVULA	G04	3
8B0081315	SEMICUSCINETTO DI BIELLA (GIALLO)	BIG END HALF BEARING (YELLOW)	DEMI-COUSSINET DI BIELLE (JAUNE)	PLEUELLAGERHÄLFTE (GELB)	SEMICOJINETE DE BIELA (AMARILLO)	G02	5
8B0081316	SEMICUSCINETTO DI BANCO (GIALLO)	CRANKSHAFT HALF BEARING (YELLOW)	DEMI-COUSSINET DE PALIER (JAUNE)	KURBELWELLENLAGERHÄLFTE (GELB)	SEMICOJINETE PRINCIPAL (AMARILLO)	G01	17
8B0081317	SEMICUSCINETTO DI BANCO (GIALLO)	CRANKSHAFT HALF BEARING (YELLOW)	DEMI-COUSSINET DE PALIER (JAUNE)	KURBELWELLENLAGERHÄLFTE (GELB)	SEMICOJINETE PRINCIPAL (AMARILLO)	G01	16
8B0084182	PASTIGLIA REGOLAZIONE GIOCO (SP.1.70)	CLEARANCE ADJUSTING PAD (THICKNESS 1.70)	PASTILLE DE CALAGE (EP.1.70)	EINSTELLPLÄTTCHEN VENTILSPIEL (STÄRKE 1.70)	PASTILLA REGULACION JUEGO (SP.1.70)	G05	21
8B0084924	CORONA	GEAR	COURONNE	ZAHNKRANZ	CORONA	C01	28
8B0089516	CAPPUCCIO CONNETTORE DIAGNOSTICA	DIAGNOSTIC CONNECTOR CAP	CAPUCHON DU CONNECTEUR DIAGNOSTIC	DIAGNOSESTECKERKAPPE	CAPUCHON CONECTADOR DE LA DIAGNOSTICA	F06	24
8B0089786	VITE M6X25	SCREW M6X25	VIS M6X25	SCHRAUBE M6X25	TORNILLO M6X25	E02	15
8B0090425	VITE M6X10	SCREW M6X10	VIS M6X10	SCHRAUBE M6X10	TORNILLO M6X10	G16	21
8B0091687	FASCETTA A VITE	SCREW CLAMP	COLLIER A VIS	SCHRAUBENSHELLE	ABRAZADERA CON ROSCA	E03	9
						K02	12
8B0091697	VITE M8X65	SCREW M8X65	VIS M8X65	SCHRAUBE M8X65	TORNILLO M8X65	G11	49
8B0092249	FASCETTA CLIC R	CLIC R CLAMP	COLLIER CLIC R	SHELLE CLIC R	ABRAZADERA CLIC R	G08	75
8B0092256	FASCETTA CLIC R	CLIC R CLAMP	COLLIER CLIC R	SHELLE CLIC R	ABRAZADERA CLIC R	K02	15
8B0096565	ROSETTA	WASHER	RONDELLE	UNTERLEGSCHEIBE	ARANDELA	G17	39
8B0098219	VITE M8X85	SCREW M8X85	VIS M8X85	SCHRAUBE M8X85	TORNILLO M8X85	G15	4
8B0098679	GUARNIZIONE TESTA (SP. 1.2)	HEAD GASKET (THICKNESS 1.2)	JOINT DE CULASSE (EP. 1.2)	ZYLINDERKOPFDICHTUNG (STÄRKE 1.2)	JUNTA CULATA (SP. 1.2)	G03	8
8B0098956	LIBRETTO USO E MANUTENZIONE (F)	USE AND MAINTENANCE HANDBOOK (F)	LIVRET UTILISATION ET ENTRETIEN (F)	BEDIENUNGSANLEITUNG (F)	MANUAL DE MANTENIMIENTO (F)	H01	5
8B00A0958	LIBRETTO USO E MANUTENZIONE (F)	USE AND MAINTENANCE HANDBOOK (F)	LIVRET UTILISATION ET ENTRETIEN (F)	BEDIENUNGSANLEITUNG (F)	MANUAL DE MANTENIMIENTO (F)	H01	5
8B00A0960	LIBRETTO USO E MANUTENZIONE (F)	USE AND MAINTENANCE HANDBOOK (F)	LIVRET UTILISATION ET ENTRETIEN (F)	BEDIENUNGSANLEITUNG (F)	MANUAL DE MANTENIMIENTO (F)	H01	5
8B00A1234	ROSETTA	WASHER	RONDELLE	UNTERLEGSCHEIBE	ARANDELA	G17	39
8B00A1529	LIBRETTO USO E MANUTENZIONE (F)	USE AND MAINTENANCE HANDBOOK (F)	LIVRET UTILISATION ET ENTRETIEN (F)	BEDIENUNGSANLEITUNG (F)	MANUAL DE MANTENIMIENTO (F)	H01	5
8B00A2533	LIBRETTO USO E MANUTENZIONE (F)	USE AND MAINTENANCE HANDBOOK (F)	LIVRET UTILISATION ET ENTRETIEN (F)	BEDIENUNGSANLEITUNG (F)	MANUAL DE MANTENIMIENTO (F)	H01	5
8B00A3065	LIBRETTO USO E MANUTENZIONE (F)	USE AND MAINTENANCE HANDBOOK (F)	LIVRET UTILISATION ET ENTRETIEN (F)	BEDIENUNGSANLEITUNG (F)	MANUAL DE MANTENIMIENTO (F)	H01	5
8B00A3920	LIBRETTO USO E MANUTENZIONE (F)	USE AND MAINTENANCE HANDBOOK (F)	LIVRET UTILISATION ET ENTRETIEN (F)	BEDIENUNGSANLEITUNG (F)	MANUAL DE MANTENIMIENTO (F)	H01	5
8C0019590	RULLINO D5X15	NEEDLE D5X15	PION D5X15	STIFT Ø 5X15	RODILLO D5X15	G01	42
8C0030362	ROSETTA	WASHER	RONDELLE	UNTERLEGSCHEIBE	ARANDELA	G10	4
						G10	19
						G17	4

INDICE CODICI / DENOMINAZIONI

CODEX / DESIGNATION INDEX • INDEX CODES / DÉNOMINATIONS

INHALTSVERZEICHNIS CODE • ÍNDICE CÓDIGOS / DENOMINACIONES

Code	Denominazione	Description	Désignation	Bezeichnung	Descripción	Table	N°
8C0036022	ROSETTA	WASHER	RONDELLE	UNTERLEGSCHIEBE	ARANDELA	G11	12
8C0069056	VITE M8X30	SCREW M8X30	VIS M8X30	SCHRAUBE M8X30	TORNILLO M8X30	J03	13
8C0084182	PASTIGLIA REGOLAZIONE GIOCO (SP.1.75)	CLEARANCE ADJUSTING PAD (THICKNESS 1.75)	PASTILLE DE CALAGE (EP.1.75)	EINSTELLPLÄTTCHEN VENTILSPIEL (STÄRKE 1.75)	PASTILLA REGULACION JUEGO (SP.1.75)	G05	21
8C0085071	VITE M6X16	SCREW M6X16	VIS M6X16	SCHRAUBE M6X16	TORNILLO M6X16	G05	9
8C0090424	VITE M5X12	SCREW M5X12	VIS M5X12	SCHRAUBE M5X12	TORNILLO M5X12	G08	37
8C0090426	VITE M8 X 16	SCREW M8 X 16	VIS M8 X 16	SCHRAUBE M8 X 16	TORNILLO M8 X 16	C02	6
8C0091697	VITE M8X70	SCREW M8X70	VIS M8X70	SCHRAUBE M8X70	TORNILLO M8X70	G15	3
8C0092249	FASCETTA CLIC R	CLIC R CLAMP	COLLIER CLIC R	SHELLE CLIC R	ABRAZADERA CLIC R	G08	47
8C0092256	FASCETTA CLIC R	CLIC R CLAMP	COLLIER CLIC R	SHELLE CLIC R	ABRAZADERA CLIC R	E03 K02	30 16
8C0098956	LIBRETTO USO E MANUTENZIONE (D)	USE AND MAINTENANCE HANDBOOK (D)	LIVRET D'UTILISATION ET ENTRETIEN (D)	BEDIENUNGSANLEITUNG (D)	MANUAL DE MANTENIMIENTO (D)	H01	5
8C00A0958	LIBRETTO USO E MANUTENZIONE (D)	USE AND MAINTENANCE HANDBOOK (D)	LIVRET D'UTILISATION ET ENTRETIEN (D)	BEDIENUNGSANLEITUNG (D)	MANUAL DE MANTENIMIENTO (D)	H01	5
8C00A0960	LIBRETTO USO E MANUTENZIONE (D)	USE AND MAINTENANCE HANDBOOK (D)	LIVRET D'UTILISATION ET ENTRETIEN (D)	BEDIENUNGSANLEITUNG (D)	MANUAL DE MANTENIMIENTO (D)	H01	5
8C00A1529	LIBRETTO USO E MANUTENZIONE (D)	USE AND MAINTENANCE HANDBOOK (D)	LIVRET UTILISATION ET ENTRETIEN (D)	BEDIENUNGSANLEITUNG (D)	MANUAL DE MANTENIMIENTO (D)	H01	5
8C00A2533	LIBRETTO USO E MANUTENZIONE (D)	USE AND MAINTENANCE HANDBOOK (D)	LIVRET UTILISATION ET ENTRETIEN (D)	BEDIENUNGSANLEITUNG (D)	MANUAL DE MANTENIMIENTO (D)	H01	5
8C00A3065	LIBRETTO USO E MANUTENZIONE (D)	USE AND MAINTENANCE HANDBOOK (D)	LIVRET UTILISATION ET ENTRETIEN (D)	BEDIENUNGSANLEITUNG (D)	MANUAL DE MANTENIMIENTO (D)	H01	5
8C00A3920	LIBRETTO USO E MANUTENZIONE (D)	USE AND MAINTENANCE HANDBOOK (D)	LIVRET UTILISATION ET ENTRETIEN (D)	BEDIENUNGSANLEITUNG (D)	MANUAL DE MANTENIMIENTO (D)	H01	5
8D0009408	ROSETTA	WASHER	RONDELLE	UNTERLEGSCHIEBE	ARANDELA	G06	11
8D0018296	ROSETTA	WASHER	RONDELLE	UNTERLEGSCHIEBE	ARANDELA	G10	27
8D0061070	VITE M6X1	SCREW M6X1	VIS M6X1	SCHRAUBE M6X1	TORNILLO M6X1	E05	29
8D0066531	VITE M5x14	SCREW M5x14	VIS M5x14	SCHRAUBE M5x14	TORNILLO M5x14	E03	2
8D0067997	VITE M5X8	SCREW M5X8	VIS M5X8	SCHRAUBE M5X8	TORNILLO M5X8	F02 G04 G11 K02	11 23 45 2
8D0081569	ROSETTA	WASHER	RONDELLE	UNTERLEGSCHIEBE	ARANDELA	G10 G17 G17	9 10 14
8D0084182	PASTIGLIA REGOLAZIONE GIOCO (SP.1.80)	CLEARANCE ADJUSTING PAD (THICKNESS 1.80)	PASTILLE DE CALAGE (EP.1.80)	EINSTELLPLÄTTCHEN VENTILSPIEL (STÄRKE 1.80)	PASTILLA REGULACION JUEGO (SP.1.80)	G05	21
8D0090424	VITE M5X14	SCREW M5X14	VIS M5X14	SCHRAUBE M5X14	TORNILLO M5X14	A01 F01	29 25
8D0090425	VITE M6X14	SCREW M6X14	VIS M6X14	SCHRAUBE M6X14	TORNILLO M6X14	E01	7
8D0095427	EPROM (F)	EPROM (F)	EPROM (F)	EPROM (F)	EPROM (F)	F06	14
8D0098956	LIBRETTO USO E MANUTENZIONE (E)	USE AND MAINTENANCE HANDBOOK (E)	LIVRET D'UTILISATION ET ENTRETIEN (E)	BEDIENUNGSANLEITUNG (E)	MANUAL DE MANTENIMIENTO (E)	H01	5
8D00A0958	LIBRETTO USO E MANUTENZIONE (E)	USE AND MAINTENANCE HANDBOOK (E)	LIVRET D'UTILISATION ET ENTRETIEN (E)	BEDIENUNGSANLEITUNG (E)	MANUAL DE MANTENIMIENTO (E)	H01	5
8D00A0960	LIBRETTO USO E MANUTENZIONE (E)	USE AND MAINTENANCE HANDBOOK (E)	LIVRET D'UTILISATION ET ENTRETIEN (E)	BEDIENUNGSANLEITUNG (E)	MANUAL DE MANTENIMIENTO (E)	H01	5
8D00A1529	LIBRETTO USO E MANUTENZIONE (E)	USE AND MAINTENANCE HANDBOOK (E)	LIVRET UTILISATION ET ENTRETIEN (E)	BEDIENUNGSANLEITUNG (E)	MANUAL DE MANTENIMIENTO (E)	H01	5
8D00A2533	LIBRETTO USO E MANUTENZIONE (E)	USE AND MAINTENANCE HANDBOOK (E)	LIVRET UTILISATION ET ENTRETIEN (E)	BEDIENUNGSANLEITUNG (E)	MANUAL DE MANTENIMIENTO (E)	H01	5
8D00A3065	LIBRETTO USO E MANUTENZIONE (E)	USE AND MAINTENANCE HANDBOOK (E)	LIVRET UTILISATION ET ENTRETIEN (E)	BEDIENUNGSANLEITUNG (E)	MANUAL DE MANTENIMIENTO (E)	H01	5
8D00A3920	LIBRETTO USO E MANUTENZIONE (E)	USE AND MAINTENANCE HANDBOOK (E)	LIVRET UTILISATION ET ENTRETIEN (E)	BEDIENUNGSANLEITUNG (E)	MANUAL DE MANTENIMIENTO (E)	H01	5

INDICE CODICI / DENOMINAZIONI

 CODEX / DESIGNATION INDEX • INDEX CODES / DÉNOMINATIONS
 INHALTSVERZEICHNIS CODE • ÍNDICE CÓDIGOS / DENOMINACIONES

Code	Denominazione	Description	Désignation	Bezeichnung	Descripción	Table	N°
8D00B2690	VITE M8X30	SCREW M8X30	VIS M8X30	SCHRAUBE M8X30	TORNILLO M8X30	A01	23
8E0067997	VITE M5X10	SCREW M5X10	VIS M5X10	SCHRAUBE M5X10	TORNILLO M5X10	G08	72
						G13	3
						G13	26
8E0084182	PASTIGLIA REGOLAZIONE GIOCO (SP.1.85)	CLEARANCE ADJUSTING PAD (THICKNESS 1.85)	PASTILLE DE CALAGE (EP.1.85)	EINSTELLPLÄTTCHEN VENTILSPIEL (STÄRKE 1.85)	PASTILLA DE REGULACION JUEGO (SP.1.85)	G05	21
8E0087431	TUBO BENZINA	FUEL PIPE	CANALISATION ESSENCE	BENZINLEITUNG	TUBO GASOLINA	G12	15
8E0090425	VITE M6X16	SCREW M6X16	VIS M6X16	SCHRAUBE M6X16	TORNILLO M6X16	B03	6
						B08	12
8E0090426	VITE M8 X 20	SCREW M8 X 20	VIS M8 X 20	SCHRAUBE M8 X 20	TORNILLO M8 X 20	C01	26
8E0092249	FASCETTA CLIC R	CLIC R CLAMP	COLLIER CLIC R	SHELLE CLIC R	ABRAZADERA CLIC R	G08	43
8E0095427	EPROM	EPROM	EPROM	EPROM	EPROM	F06	14
8F0081569	ROSETTA	WASHER	RONDELLE	UNTERLEGSCHEIBE	ARANDELA	G10	10
8F0084182	PASTIGLIA REGOLAZIONE GIOCO (SP.1.90)	CLEARANCE ADJUSTING PAD (THICKNESS 1.90)	PASTILLE DE CALAGE (EP.1.90)	EINSTELLPLÄTTCHEN VENTILSPIEL (STÄRKE 1.90)	PASTILLA REGULACION JUEGO (SP.1.90)	G05	21
8F0090425	VITE M6X18	SCREW M6X18	VIS M6X18	SCHRAUBE M6X18	TORNILLO M6X18	F03	20
8F0090426	VITE M8x22	SCREW M8x22	VIS M8x22	SCHRAUBE M8x22	TORNILLO M8x22	D01	14
						D02	14
						D02	24
8F0092249	FASCETTA CLIC R	CLIC R CLAMP	COLLIER CLIC R	SHELLE CLIC R	ABRAZADERA CLIC R	G08	58
8F0095427	EPROM (F)	EPROM (F)	EPROM (F)	EPROM (F)	EPROM (F)	F06	14
8G0004551	ROSETTA	WASHER	RONDELLE	UNTERLEGSCHEIBE	ARANDELA	G11	34
8G0048590	ROSETTA	WASHER	RONDELLE	UNTERLEGSCHEIBE	ARANDELA	G10	13
						G17	14
8G0070266	TUBO SERBATOIO/ POMPA FRENO	FUEL TANK/BRAKE PUMP PIPE	CANALISATION RESERVOIR/ MAITRE-CYLINDRE	LEITUNG BREMSFLÜSSIGKEITS- BEHÄLTER/ BREMSPUMPE	TUBO TANQUE/ BOMBA FRENO	D02	22
8G0084182	PASTIGLIA REGOLAZIONE GIOCO (SP.1.95)	CLEARANCE ADJUSTING PAD (THICKNESS 1.95)	PASTILLE DE CALAGE (EP.1.95)	EINSTELLPLÄTTCHEN VENTILSPIEL (STÄRKE 1.95)	PASTILLA REGULACION JUEGO (SP.1.95)	G05	21
8G0088581	CENTRALINA INIEZIONE	INJECTION POWER UNIT	BOITIER DE CONTROLE INJECTION	EINSPRITZ-STEUERUNG	CENTRALITA INJECCION	F06	13
8G0090425	VITE M6X20	SCREW M6X20	VIS M6X20	SCHRAUBE M6X20	TORNILLO M6X20	B02	4
						D01	19
						D01	20
						D02	19
						D03	3
						D04	3
						E02	22
						G16	19
8G0090426	VITE M8x25	SCREW M8x25	VIS M8x25	SCHRAUBE M8x25	TORNILLO M8x25	A03	36
						B03	15
						D01	13
						D02	13
8G0092249	FASCETTA CLIC R	CLIC R CLAMP	COLLIER CLIC R	SHELLE CLIC R	ABRAZADERA CLIC R	G08	19
						G08	46
						G08	52
8H0067545	VITE M6X12	SCREW M6X12	VIS M6X12	SCHRAUBE M6X12	TORNILLO M6X12	A02	19
						A03	21
						E05	37
						E05	42
						G08	79
8H0082751	VITE M10X26	SCREW M10X26	VIS M10X26	SCHRAUBE M10X26	TORNILLO M10X26	C02	17
8H0084182	PASTIGLIA REGOLAZIONE GIOCO (SP.2.00)	CLEARANCE ADJUSTING PAD (THICKNESS 2.00)	PASTILLE DE CALAGE (EP.2.00)	EINSTELLPLÄTTCHEN VENTILSPIEL (STÄRKE 2.00)	PASTILLA REGULACION JUEGO (SP.2.00)	G05	21
8H0087431	TUBO BENZINA	FUEL PIPE	CANALISATION ESSENCE	BENZINLEITUNG	TUBO GASOLINA	G12	16

INDICE CODICI / DENOMINAZIONI

CODEX / DESIGNATION INDEX • INDEX CODES / DÉNOMINATIONS

INHALTSVERZEICHNIS CODE • ÍNDICE CÓDIGOS / DENOMINACIONES

Code	Denominazione	Description	Désignation	Bezeichnung	Descripción	Table	N°
8H0090424	VITE M5X22	SCREW M5X22	VIS M5X22	SCHRAUBE M5X22	TORNILLO M5X22	F04	19
8H0090425	VITE M6X22	SCREW M6X22	VIS M6X22	SCHRAUBE M6X22	TORNILLO M6X22	A01	35
						B03	7
						D03	8
						D03	19
						D04	9
8H0095427	EPROM	EPROM	EPROM	EPROM	EPROM	F06	14
8J0084182	PASTIGLIA REGOLAZIONE GIOCO (SP.2.05)	CLEARANCE ADJUSTING PAD (THICKNESS 2.05)	PASTILLE DE CALAGE (EP.2.05)	EINSTELLPLÄTTCHEN VENTILSPIEL (STÄRKE 2.05)	PASTILLA REGULACION JUEGO (SP.2.05)	G05	21
8J0090425	VITE M6X25	SCREW M6X25	VIS M6X25	SCHRAUBE M6X25	TORNILLO M6X25	B08	15
						D03	2
						D03	4
						D04	2
						D04	4
						F07	9
8J0090426	VITE M8X30	SCREW M8X30	VIS M8X30	SCHRAUBE M8X30	TORNILLO M8X30	A02	7
						A03	7
8J0095427	EPROM	EPROM	EPROM	EPROM	EPROM	F06	14
8K0084182	PASTIGLIA REGOLAZIONE GIOCO (SP.2.10)	CLEARANCE ADJUSTING PAD (THICKNESS 2.10)	PASTILLE DE CALAGE (EP.2.10)	EINSTELLPLÄTTCHEN VENTILSPIEL (STÄRKE 2.10)	PASTILLA REGULACION JUEGO (SP.2.10)	G05	21
8K0088581	CENTRALINA INIEZIONE (F)	INJECTION POWER UNIT (F)	BOITIER DE CONTROLE INJECTION (F)	EINSPRITZ-STEUERUNG (F)	CENTRALITA INJECCION (F)	F06	13
8K0090426	VITE M8X35	SCREW M8X35	VIS M8X35	SCHRAUBE M8X35	TORNILLO M8X35	A02	8
						A03	8
8L0082751	VITE M10X31	SCREW M10X31	VIS M10X31	SCHRAUBE M10X31	TORNILLO M10X31	B01	20
						C02	16
8L0084182	PASTIGLIA REGOLAZIONE GIOCO (SP.2.15)	CLEARANCE ADJUSTING PAD (THICKNESS 2.15)	PASTILLE DE CALAGE (EP.2.15)	EINSTELLPLÄTTCHEN VENTILSPIEL (STÄRKE 2.15)	PASTILLA REGULACION JUEGO (SP.2.15)	G05	21
8L0088581	CENTRALINA INIEZIONE	INJECTION POWER UNIT	BOITIER DE CONTROLE INJECTION	EINSPRITZ-STEUERUNG	CENTRALITA INJECCION	F06	13
8L0090424	VITE M5X30	SCREW M5X30	VIS M5X30	SCHRAUBE M5X30	TORNILLO M5X30	B03	14
8L0090425	VITE M6X30	SCREW M6X30	VIS M6X30	SCHRAUBE M6X30	TORNILLO M6X30	G16	11
8L0092249	FASCETTA CLIC R	CLIC R CLAMP	COLLIER CLIC R	SHELLE CLIC R	ABRAZADERA CLIC R	G08	73
8M0066179	TUBO IN GOMMA	HOSE	DURIT	GUMMISCHLAUCH	TUBO DE GOMA	G08	40
8M0084182	PASTIGLIA REGOLAZIONE GIOCO (SP.2.20)	CLEARANCE ADJUSTING PAD (THICKNESS 2.20)	PASTILLE DE CALAGE (EP.2.20)	EINSTELLPLÄTTCHEN VENTILSPIEL (STÄRKE 2.20)	PASTILLA REGULACION JUEGO (SP.2.20)	G05	21
8M0088581	CENTRALINA INIEZIONE (F)	INJECTION POWER UNIT (F)	BOITIER DE CONTROLE INJECTION (F)	EINSPRITZ-STEUERUNG (F)	CENTRALITA INJECCION (F)	F06	13
8M0090425	VITE M6X35	SCREW M6X35	VIS M6X35	SCHRAUBE M6X35	TORNILLO M6X35	E01	5
						G16	23
8M0092249	FASCETTA CLIC R	CLIC R CLAMP	COLLIER CLIC R	SHELLE CLIC R	ABRAZADERA CLIC R	G08	65
						G08	81
						G12	14
8M0095427	EPROM (F)	EPROM (F)	EPROM (F)	EPROM (F)	EPROM (F)	F06	14
8N0084182	PASTIGLIA REGOLAZIONE GIOCO (SP.2.25)	CLEARANCE ADJUSTING PAD (THICKNESS 2.25)	PASTILLE DE CALAGE (EP.2.25)	EINSTELLPLÄTTCHEN VENTILSPIEL (STÄRKE 2.25)	PASTILLA REGULACION JUEGO (SP.2.25)	G05	21
8N0095427	EPROM (JPN)	EPROM (JPN)	EPROM (JPN)	EPROM (JPN)	EPROM (JPN)	F06	14
8P0082751	VITE M10X45	SCREW M10X45	VIS M10X45	SCHRAUBE M10X45	TORNILLO M10X45	B02	7
8P0084182	PASTIGLIA REGOLAZIONE GIOCO (SP.2.30)	CLEARANCE ADJUSTING PAD (THICKNESS 2.30)	PASTILLE DE CALAGE (EP.2.30)	EINSTELLPLÄTTCHEN VENTILSPIEL (STÄRKE 2.30)	PASTILLA REGULACION JUEGO (SP.2.30)	G05	21
8P0088581	CENTRALINA INIEZIONE	INJECTION POWER UNIT	BOITIER DE CONTROLE INJECTION	EINSPRITZ-STEUERUNG	CENTRALITA INJECCION	F06	13
8P0095427	EPROM (JPN)	EPROM (JPN)	EPROM (JPN)	EPROM (JPN)	EPROM (JPN)	F06	14
8PA067545	VITE M6X22	SCREW M6X22	VIS M6X22	SCHRAUBE M6X22	TORNILLO M6X22	G13	21

INDICE CODICI / DENOMINAZIONI

 CODEX / DESIGNATION INDEX • INDEX CODES / DÉNOMINATIONS
 INHALTSVERZEICHNIS CODE • ÍNDICE CÓDIGOS / DENOMINACIONES

Code	Denominazione	Description	Désignation	Bezeichnung	Descripción	Table	N°
8Q0092249	FASCETTA CLIC R	CLIC R CLAMP	COLLIER CLIC R	SHELLE CLIC R	ABRAZADERA CLIC R	G08	44
8R0082751	VITE M10X50	SCREW M10X50	VIS M10X50	SCHRAUBE M10X50	TORNILLO M10X50	B02	19
8R0084182	PASTIGLIA REGOLAZIONE GIOCO (SP.2.35)	CLEARANCE ADJUSTING PAD (THICKNESS 2.35)	PASTILLE DE CALAGE (EP.2.35)	EINSTELLPLÄTTCHEN VENTILSPIEL (STÄRKE 2.35)	PASTILLA REGULACION JUEGO (SP.2.35)	G05	21
8R0088581	CENTRALINA INIEZIONE	INJECTION POWER UNIT	BOITIER DE CONTROLE INJECTION	EINSPRITZ-STEUERUNG	CENTRALITA INJECCION	F06	13
8R0095427	EPROM (JPN)	EPROM (JPN)	EPROM (JPN)	EPROM (JPN)	EPROM (JPN)	F06	14
8S0082751	VITE M10X55	SCREW M10X55	VIS M10X55	SCHRAUBE M10X55	TORNILLO M10X55	B02	18
8S0084182	PASTIGLIA REGOLAZIONE GIOCO (SP.2.40)	CLEARANCE ADJUSTING PAD (THICKNESS 2.40)	PASTILLE DE CALAGE (EP.2.40)	EINSTELLPLÄTTCHEN VENTILSPIEL (STÄRKE 2.40)	PASTILLA REGULACION JUEGO (SP.2.40)	G05	21
8S0090425	VITE M6X55	SCREW M6X55	VIS M6X55	SCHRAUBE M6X55	TORNILLO M6X55	F01	3
8S0092249	FASCETTA CLIC R	CLIC R CLAMP	COLLIER CLIC R	SHELLE CLIC R	ABRAZADERA CLIC R	G12	22
8S0095427	EPROM (JPN)	EPROM (JPN)	EPROM (JPN)	EPROM (JPN)	EPROM (JPN)	F06	14
8SA067545	VITE M6X8	SCREW M6X8	VIS M6X8	SCHRAUBE M6X8	TORNILLO M6X8	F04	7
						F04	9
8T0084182	PASTIGLIA REGOLAZIONE GIOCO (SP.2.45)	CLEARANCE ADJUSTING PAD (THICKNESS 2.45)	PASTILLE DE CALAGE (EP.2.45)	EINSTELLPLÄTTCHEN VENTILSPIEL (STÄRKE 2.45)	PASTILLA REGULACION JUEGO (SP.2.45)	G05	21
8T0088581	CENTRALINA INIEZIONE (F)	INJECTION POWER UNIT (F)	BOITIER DE CONTROLE INJECTION (F)	EINSPRITZ-STEUERUNG (F)	CENTRALITA INJECCION (F)	F06	13
8U0084182	PASTIGLIA REGOLAZIONE GIOCO (SP.2.50)	CLEARANCE ADJUSTING PAD (THICKNESS 2.50)	PASTILLE DE CALAGE (EP.2.50)	EINSTELLPLÄTTCHEN VENTILSPIEL (STÄRKE 2.50)	PASTILLA REGULACION JUEGO (SP.2.50)	G05	21
8U0088581	CENTRALINA INIEZIONE (JPN)	INJECTION POWER UNIT (JPN)	BOITIER DE CONTROLE INJECTION (JPN)	EINSPRITZ-STEUERUNG (JPN)	CENTRALITA INJECCION (JPN)	F06	13
8U0092249	FASCETTA CLIC R	CLIC R CLAMP	COLLIER CLIC R	SHELLE CLIC R	ABRAZADERA CLIC R	G08	57
8V0067545	VITE M6X135	SCREW M6X135	VIS M6X135	SCHRAUBE M6X135	TORNILLO M6X135	G01	9
8V0084182	PASTIGLIA REGOLAZIONE GIOCO (SP.2.55)	CLEARANCE ADJUSTING PAD (THICKNESS 2.55)	PASTILLE DE CALAGE (EP.2.55)	EINSTELLPLÄTTCHEN VENTILSPIEL (STÄRKE 2.55)	PASTILLA REGULACION JUEGO (SP.2.55)	G05	21
8V0088581	CENTRALINA INIEZIONE (JPN)	INJECTION POWER UNIT (JPN)	BOITIER DE CONTROLE INJECTION (JPN)	EINSPRITZ-STEUERUNG (JPN)	CENTRALITA INJECCION (JPN)	F06	13
8W0084182	PASTIGLIA REGOLAZIONE GIOCO (SP.2.60)	CLEARANCE ADJUSTING PAD (THICKNESS 2.60)	PASTILLE DE CALAGE (EP.2.60)	EINSTELLPLÄTTCHEN VENTILSPIEL (STÄRKE 2.60)	PASTILLA REGULACION JUEGO (SP.2.60)	G05	21
8W0088581	CENTRALINA INIEZIONE (JPN)	INJECTION POWER UNIT (JPN)	BOITIER DE CONTROLE INJECTION (JPN)	EINSPRITZ-STEUERUNG (JPN)	CENTRALITA INJECCION (JPN)	F06	13
8Y0088581	CENTRALINA INIEZIONE (JPN)	INJECTION POWER UNIT (JPN)	BOITIER DE CONTROLE INJECTION (JPN)	EINSPRITZ-STEUERUNG (JPN)	CENTRALITA INJECCION (JPN)	F06	13



A series of horizontal dotted lines for writing, spanning the width of the page.



MV AGUSTA S.p.A. - Servizio Assistenza Tecnica
Via Giovanni Macchi, 144 - 21100 Varese (VA) ITALY
Tel. (Italia) 800.36.44.06 - (estero) ++39 0332 254.712
Fax ++39 0332 329.379 - sito web "www.mvagusta.it"
Part. N. 800098957 Edizione N° 5