



Motorcycle Art

BRUTALE



MV AGUSTA BRUTALE 990 R - 1090 RR - BRUTALE

Catalogo ricambi

Spare parts catalogue

Catalogue des pièces détachées

Ersatzteilkatalog

Catálogo de recambios

© 2011

È vietata la riproduzione anche parziale di questo documento senza il consenso scritto della MV Agusta Motor S.p.A.

Part. n° 8000B3254 - Edizione n° 4
Stampato nel Marzo 2011



SCOPO DEL CATALOGO

Questo catalogo è stato realizzato per la sola ordinazione delle parti di ricambio.

Per ottenere qualsiasi altra informazione è necessario consultare il manuale d'officina o contattare direttamente il costruttore.

PURPOSE OF THE CATALOGUE

This catalogue has been designed for spare parts ordering only.

To obtain any other information you should check the servicing manual or contact the manufacturer directly.

ZWECK DES KATALOGS

Dieser Katalog dient ausschliesslich der Bestellung von Ersatzteilen.

Für alle weiteren Informationen im technischen Handbuch nachschlagen oder direkt den Hersteller kontaktieren.

VALIDITÀ DEL CATALOGO

Le informazioni contenute in questo catalogo si riferiscono unicamente ai motocicli con numero di matricola telaio uguale o superiore a: **(ZCGB510AA AV) 000011 (Brutale 990 R) / (ZCGB520AA AV) 000018 (Brutale 1090 RR)**

EFFECTIVENESS OF THE CATALOGUE

The information contained in this catalogue only refers to motorcycles with a frame serial number equal or upper than **(ZCGB510AA AV) 000011 (Brutale 990 R) / (ZCGB520AA AV) 000018 (Brutale 1090 RR)**.

GÜLTIGKEIT DES KATALOGS

Die Informationen in dieser Katalog enthalten gelten nur für die Motorrad mit ein Rahmennummer gleich oder mehr als **(ZCGB510AA AV) 000011 (Brutale 990 R) / (ZCGB520AA AV) 000018 (Brutale 1090 RR)**.

STRUTTURA DEL CATALOGO

Nell'illustrazione sono riportate alcune informazioni per interpretare il contenuto del catalogo.

CATALOGUE STRUCTURE

The picture contains some instructions on how to use the catalogue.

AUFBAU DES KATALOGS

In der Erläuterung sind einige Informationen für die richtige Interpretation des Kataloginhalts angeführt.

BUT DE CATALOGUE

Ce catalogue a été exclusivement réalisé pour commander des pièces détachées. Pour avoir toute autre information, consulter le manuel d'entretien ou bien prendre contact directement avec le constructeur.

FINALIDAD DEL CATÁLOGO

Este catálogo se ha realizado sólo para el pedido de las piezas de recambio. Para cualquier otra información es necesario consultar el manual de taller o ponerse en contacto directo con el fabricante.

VALIDITÉ DE CATALOGUE

Les informations contenu en ce catalogue se réfèrent uniquement à les motos avec un numéro de matricule du cadre égal ou supérieur à **(ZCGB510AA AV) 000011 (Brutale 990 R) / (ZCGB520AA AV) 000018 (Brutale 1090 RR)**.

VALIDEZ DEL CATÁLOGO

La información en el interior de este manual corresponde solo a las motocicletas con un número de matrícula bastidor a partir de **(ZCGB510AA AV) 000011 (Brutale 990 R) / (ZCGB520AA AV) 000018 (Brutale 1090 RR)**.

STRUCTURE DE CATALOGUE

L'illustration contient quelques renseignements pour mieux interpréter le contenu du catalogue.

ESTRUCTURA DEL CATÁLOGO

En la ilustración se dan algunas informaciones para interpretar el contenido del catálogo.

Numeri di riferimento, codice e quantità.
Reference numbers, code and quantity.
numéros de référence, code et quantité.
Bezugsnummern, Code und Menge.
Números de referencia, código y cantidad.

Specifiche (es: area di commercializzazione, caratteristiche costruttive, colori, note, ecc.)
Specifications (e.g. marketing area, construction characteristics, colours, notes etc.).
Specifications (par ex. zone de commercialisation, caractéristiques de construction, couleurs, notes etc.).
Spezifische Angaben (z.B. Handelsgebiet, Herstellungseigenschaften, Farben, Hinweise, usw.).
Especificaciones (ej: área de comercialización, características de fabricación, colores, notas, etc.).

Validità con riferimento matricola telaio e matricola motore.
Validity referred to frame serial number and engine serial number.
Validité concernant le matricule du châssis et le matricule du moteur.
Gültigkeit mit Bezug auf die Rahmen- und Motornummer.
Validez referida a la matrícula bastidor y matrícula motor.

N.	Code	Q.ty	Note	Brutale 990 R	Brutale 1090 RR	► I FRAME ►	► I ENGINE ►
1	80A0B2993	1		•	•		
2	8000B4014	1		•	•		
3	8000B3004	2		•	•		
4	800090417	2		•	•		
5	800097899	1		•	•		
5	80C097899	1			•		
6	800097900	1		•	•		
6	80C097900	1			•		
7	800087476	2		•	•		
8	80A090392	4		•	•		
9	8E00B2681	2		•	•		
10	8A0084857	2		•	•		
11	8000B2757	1		•	•		
12	8000B2756	1		•	•		
13	8000B2715	2		•	•		
14	8000B2750	2		•	•		
15	80A089804	1		•	•		
16	800089781	1		•	•		
16	80B089781	1			•		
17	80A090431	1		•	•		
18	80A090432	1		•	•		
19	800098706	1		•	•		

Modelli motocicletta.
Motorcycle models.
Modèles de moto.
Motorradmodelle.
Modelos motocicleta.

Numero di tavola e di edizione.
Plate and edition number.
Numéro de planche et d'édition.
Tafelnummer und Nummer der Ausgabe.
Número de tabla y de edición.

Note a piè di pagina.
Footnotes.
Notes au bas de la page.
Fussnoten.
Notas al pie de la página.

Numero di tabella e di edizione.
Table and edition number.
Numéro de tableau et d'édition.
Tabellenummer und Nummer der Ausgabe.
Número de ilustración y de edición.



INTRODUZIONE AL CATALOGO RICAMBI

INTRODUCTION TO THE SPARE PARTS CATALOGUE • INTRODUCTION AU CATALOGUE DES PIÈCES DÉTACHÉES
EINFÜHRUNG IN DEN ERSATZTEILKATALOG • INTRODUCCIÓN AL CATÁLOGO DE RECAMBIOS

SIMBOLI E ABBREVIAZIONI

- ▶ I Validità fino alla matricola **F USA** ...Valido solo per versione Francia, USA... **A B** ...Codice colore
▶ Validità dalla matricola **1 2** ...Note a piè pagina **≠** ...Spessore

SYMBOLS AND ABBREVIATIONS

- ▶ I Validity up to serial number
▶ Validity from serial number
F USA ...Valid for (France, Usa ...) version only
1 2 ...Footnotes
A B ...Colour code
≠ Thickness

SYMBOLS UND ABKÜRZUNGEN

- ▶ I Gültig ab der Kennummer
▶ Gültig bis zur Kennummer
F USA ...Gilt nur die Ausführung für Frankreich, die USA...
1 2 ...Fussnoten
A B ...Farbcode
≠ Stärke

SYMBOLS ET ABRÉVIATIONS

- ▶ I Validité jusqu'au matricule
▶ Validité à partir du matricule
F USA ...Valable uniquement pour la variante France, Usa, etc.
1 2 ...Notes au bas de la page
A B ...Code couleur
≠ Épaisseur

SÍMBOLOS Y ABBREVIACIONES

- ▶ I Validez hasta la matrícula
▶ Validez a partir de la matrícula
F USA ...Válido sólo para los modelos Francia, USA, ...
1 2 ...Notas al pie de la página
A B ...Código color
≠ Grosor

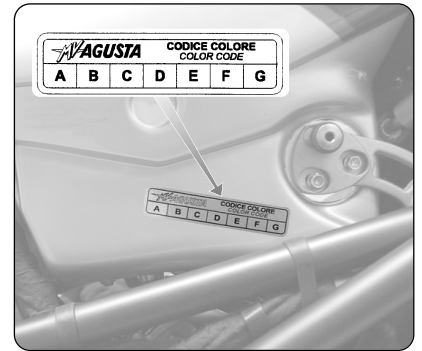

Le misure sono espresse in mm.
Measures are expressed in mm.
Les mesures sont exprimées en mm.
Die Masse sind in mm angegeben.
Las medidas están expresadas en mm.

COME CONSULTARE IL CATALOGO RICAMBI

- 1) Identificare la parte di interesse e relativo numero di tavola.
- 2) Rintracciare la tavola all'interno del catalogo.
- 3) Identificare la parte ed il relativo numero di riferimento all'interno della tavola esplosa.
- 4) Identificare il numero di codice della parte in base al numero di riferimento e al modello di motocicletta.
- 5) Controllare la presenza di note e validità.

HOW TO CHECK THE SPARE PARTS CATALOGUE

- 1) Locate your part of interest and the relevant plate number.
- 2) Find the plate in the catalogue.
- 3) Locate the part and the corresponding reference number within the exploded view plate.
- 4) Locate the part code number according to the reference number and the motorcycle model.
- 5) Check any footnotes and validity information.

COMMENT CONSULTER LE CATALOGUE DES PIÈCES DÉTACHÉES

- 1) Identifier la pièce qui vous intéresse et le numéro de planche correspondant.
- 2) Repérer la planche à l'intérieur du catalogue.
- 3) Identifier la pièce et le numéro de référence correspondant à l'intérieur de la planche éclatée.
- 4) Identifier le code de la pièce sur la base du numéro de référence et du modèle de moto.
- 5) Contrôler la présence de notes et la validité.

NACHSCHLAGEN IM ERSATZTEILKATALOG

- 1) Das gewünschte Ersatzteil und die entsprechende Tafel feststellen.
- 2) Die Tafel im Katalog suchen.
- 3) Das Teil und die dazugehörige Bezugsnummer auf der Explosions-tafel suchen.
- 4) Aufgrund der Bezugsnummer und des Motorradmodells den Code des Ersatzteils bestimmen.
- 5) Kontrollieren, ob Hinweise oder Angaben zur Gültigkeit angeführt sind.

COMO CONSULTAR EL CATALOGO DE RECAMBIOS

- 1) Identificar la parte que interesa y el correspondiente número de tabla.
- 2) Buscar la tabla en el interior del catálogo.
- 3) Identificar la pieza y el correspondiente número de referencia en el interior de la tabla de despiece.
- 4) Identificar el número de código de la pieza en función del número de referencia y del modelo de la motocicleta.
- 5) Controlar si hay notas y la validez.

N.	Code	Q.ty	Note	Bruttare 990 R	PI FRAME IP	PI ENGINE IP
1	80002664	1				
2	800019898	1				
3	80005962	1				
3	80E098314	1				
3	80C098314	1				

Indice figurativo.
Figurative index.
Index figuratif.
Bildverzeichnis.
Índice de figuras.

INTRODUZIONE AL CATALOGO RICAMBI

INTRODUCTION TO THE SPARE PARTS CATALOGUE • INTRODUCTION AU CATALOGUE DES PIÈCES DÉTACHÉES
EINFÜHRUNG IN DEN ERSATZTEILKATALOG • INTRODUCCIÓN AL CATÁLOGO DE RECAMBOS



COME ORDINARE LE PARTI DI RICAMBIO

Nel modulo di ordinazione riportare:

- 1 Il numero di codice della parte
- 2 La quantità richiesta
- 3 Il modello di motocicletta
- 4 Il numero di telaio

HOW TO ORDER SPARE PARTS

In the order form quote:

- 1 The part code number
- 2 Your required amount
- 3 The motorcycle model
- 4 The frame number

BESTELLUNG VON ERSATZTEILEN

In das Bestellformular sind einzutragen:

- 1 Der Code des Ersatzteils
- 2 Die gewünschte Anzahl
- 3 Das Motorradmodell
- 4 Die Rahmennummer

COMMENT COMMANDER LES PIÈCES DÉTACHÉES

Dans le formulaire de commande spécifier:

- 1 Le numéro de code de la pièce
- 2 La quantité voulue
- 3 Le modèle de moto
- 4 Le numéro de cadre

COMO PEDIR LAS PIEZAS DE RECAMBIO

Indicar en el impreso de pedido:

- 1 El número de código de la pieza
- 2 La cantidad solicitada
- 3 El modelo de motocicleta
- 4 El número de bastidor

FAC SIMILE SCHEDA DI ORDINAZIONE
ORDER FORM FACSIMILE
FAC-SIMILE DE LA FICHE DE COMMANDE
FAKSIMILE DES BESTELLBLÄTTER
FAC SIMIL FICHA DE PEDIDO

AGUSTA Motor S.p.A.

Data Date - Datum Datum - Fecha		Mittente Sender - Expéditeur Absender - Remitente		Cod. concessionario Dealer code - Code du concessionnaire Kartnummer des Vertragshändlers - Cod. concessionario	
Stock Stock - Stock Lagerbestand - Stock	<input type="checkbox"/>	Urgente Urgent - Urgent Dringend - Urgente	<input type="checkbox"/>	Modalità di spedizione Shipping information - Mode d'expédition Versandbestimmungen - Modalidad de envío	
Modello Model-Motocicleta Modèle-Motocicleta	Telaio Frame-Châssis Rahmen-Bastidor	Motore Engine-Motor Motor-Motor	Codice Code - Code Code - Codeign	Qty.	Modello Model-Motocicleta Modèle-Motocicleta
Telaio Frame-Châssis Rahmen-Bastidor	Motore Engine-Motor Motor-Motor	Codice Code - Code Code - Codeign	Qty.	Modello Model-Motocicleta Modèle-Motocicleta	Telaio Frame-Châssis Rahmen-Bastidor
Motore Engine-Motor Motor-Motor	Codice Code - Code Code - Codeign	Qty.	Modello Model-Motocicleta Modèle-Motocicleta	Telaio Frame-Châssis Rahmen-Bastidor	Motore Engine-Motor Motor-Motor
Codice Code - Code Code - Codeign	Qty.	Modello Model-Motocicleta Modèle-Motocicleta	Telaio Frame-Châssis Rahmen-Bastidor	Motore Engine-Motor Motor-Motor	Codice Code - Code Code - Codeign
Qty.		Modello Model-Motocicleta Modèle-Motocicleta	Telaio Frame-Châssis Rahmen-Bastidor	Motore Engine-Motor Motor-Motor	Codice Code - Code Code - Codeign

N.	Code	Qty	Note	Brutale 990 R	Brutale 1090 RR	► I FRAME ◀	► I ENGINE ◀
1	800092664	1		.	.		
2	8000A9698	1		.	.		

ASSEMBLEO SERBATOIO BENZINA
ECLAIRAGE ACCESSORI • ACCESSOIRES DE LA CARROSSERIE
BAGNAPPEL • INNEN - CONJUNTO DE DEPÓSITO GASOLINA

N.	Code	Qty	Note	Brutale 990 R	Brutale 1090 RR	► I FRAME ◀	► I ENGINE ◀
1	800010000	1					
2	800010000	1					
3	800010000	1					
4	800010000	1					
5	800010000	1					
6	800010000	1					
7	800010000	1					
8	800010000	1					
9	800010000	1					
10	800010000	1					
11	800010000	1					
12	800010000	1					
13	800010000	1					
14	800010000	1					
15	800010000	1					
16	800010000	1					
17	800010000	1					
18	800010000	1					
19	800010000	1					
20	800010000	1					
21	800010000	1					
22	800010000	1					
23	800010000	1					
24	800010000	1					
25	800010000	1					
26	800010000	1					
27	800010000	1					
28	800010000	1					
29	800010000	1					
30	800010000	1					

4
Numero di matricola telaio.
Frame serial number.
Numéro de matricule du cadre.
Rahmennummer.
Número de matrícula bastidor.

4
Numero di matricola motore.
Engine serial number.
Numéro de série moteur.
Motornummer.
Número de matrícula motor.



INDICE DESCRITTIVO

DESCRIPTIVE INDEX • INDEX DESCRIPTIF
BESCHREIBENDES INHALTSVERZEICHNIS • ÍNDICE DESCRIPTIVO

A01
3

ASSIEME TELAIO

FRAME ASSEMBLY • ENSEMBLE CADRE
BAUGRUPPE RAHMEN • CONJUNTO BASTIDOR

A02
2

ASSIEME TELAIO POSTERIORE

REAR FRAME ASSEMBLY • ENSEMBLE CADRE ARRIÈRE
BAUGRUPPE HINTERER RAHMEN • CONJUNTO BASTIDOR TRASERO

B01
3

ASSIEME FORCELLONE

SWINGING ARM ASSEMBLY • ENSEMBLE FOURCHE
BAUGRUPPE GABEL • CONJUNTO HORQUILLA

B02
2

ASSIEME SOSPENSIONE POSTERIORE

REAR SUSPENSION ASSEMBLY • ENSEMBLE SUSPENSION ARRIÈRE
BAUGRUPPE HINTERRADAUFHÄNGUNG • CONJUNTO SUSPENSIÓN TRASERA

B03
3

ASSIEME SOSPENSIONE ANTERIORE

FRONT SUSPENSION ASSEMBLY • ENSEMBLE SUSPENSION AVANT
BAUGRUPPE VORDERRADAUFHÄNGUNG • CONJUNTO SUSPENSIÓN DELANTERA

B04
2

FORCELLA DESTRA (B5 990 R / BRUTALE MY 2011)

RIGHT-HAND FORK (B5 990 R / BRUTALE MY 2011) • FOURCHE DROITE (B5 990 R / BRUTALE MY 2011)
RECHTE GABEL (B5 990 R / BRUTALE MY 2011) • HORQUILLA DERECHA (B5 990 R / BRUTALE MY 2011)

B05
2

FORCELLA SINISTRA (B5 990 R / BRUTALE MY 2011)

LEFT-HAND FORK (B5 990 R / BRUTALE MY 2011) • FOURCHE GAUCHE (B5 990 R / BRUTALE MY 2011)
LINKE GABEL (B5 990 R / BRUTALE MY 2011) • HORQUILLA IZQUIERDA (B5 990 R / BRUTALE MY 2011)

B06
2

FORCELLA DESTRA (BRUTALE 1090 RR)

RIGHT-HAND FORK (BRUTALE 1090 RR) • FOURCHE DROITE (BRUTALE 1090 RR)
RECHTE GABEL (BRUTALE 1090 RR) • HORQUILLA DERECHA (BRUTALE 1090 RR)

B07
2

FORCELLA SINISTRA (BRUTALE 1090 RR)

LEFT-HAND FORK (BRUTALE 1090 RR) • FOURCHE GAUCHE (BRUTALE 1090 RR)
LINKE GABEL (BRUTALE 1090 RR) • HORQUILLA IZQUIERDA (BRUTALE 1090 RR)

C01
3

ASSIEME RUOTA POSTERIORE

REAR WHEEL ASSEMBLY • ENSEMBLE ROUE ARRIÈRE
BAUGRUPPE HINTERRAD • CONJUNTO RUEDA TRASERA

C02
1

ASSIEME RUOTA ANTERIORE (B5 990 R / BRUTALE MY 2011)

FRONT WHEEL ASSEMBLY (B5 990 R / BRUTALE MY 2011) • ENSEMBLE ROUE AVANT (B5 990 R / BRUTALE MY 2011)
BAUGRUPPE VORDERRAD (B5 990 R / BRUTALE MY 2011) • CONJUNTO RUEDA DELANTERA (B5 990 R / BRUTALE MY 2011)

C03
2

ASSIEME RUOTA ANTERIORE (BRUTALE 1090 RR)

FRONT WHEEL ASSEMBLY (BRUTALE 1090 RR) • ENSEMBLE ROUE AVANT (BRUTALE 1090 RR)
BAUGRUPPE VORDERRAD (BRUTALE 1090 RR) • CONJUNTO RUEDA DELANTERA (BRUTALE 1090 RR)

D01
2

ASSIEME PEDANA SINISTRA

LEFT-HAND FOOTREST ASSEMBLY • ENSEMBLE REPOSE-PIEDS GAUCHE
BAUGRUPPE LINKES FUSSBRETT • CONJUNTO ESTRIBO IZQUIERDO

D02
2

ASSIEME PEDANA DESTRA

RIGHT-HAND FOOTREST ASSEMBLY • ENSEMBLE REPOSE-PIEDS DROIT
BAUGRUPPE RECHTES FUSSBRETT • CONJUNTO ESTRIBO DERECHO

**D03**
2**ASSIEME MANUBRIO (LATO DESTRO)**HANDLEBAR ASSEMBLY (RIGHT SIDE) • ENSEMBLE GUIDON (CÔTÉ DROIT)
BAUGRUPPE LENKER (RECHTE SEITE) • CONJUNTO MANILLAR (LADO DERECHO)**D04**
2**ASSIEME MANUBRIO (LATO SINISTRO)**HANDLEBAR ASSEMBLY (LEFT SIDE) • ENSEMBLE GUIDON (CÔTÉ GAUCHE)
BAUGRUPPE LENKER (LINKE SEITE) • CONJUNTO MANILLAR (LADO IZQUIERDO)**D05**
2**SERRATURE**LOCKS • VERROUILLAGES
SCHLÖSSER • CERRADURAS**E01**
3**ASSIEME CARENATURE**FAIRING ASSEMBLY • ENSEMBLE CARÉNAGE
BAUGRUPPE KAROSSERIE UND VERKLEIDUNG • CONJUNTO CARENADOS**E02**
3**ASSIEME CARENATURE**FAIRING ASSEMBLY • ENSEMBLE CARÉNAGE
BAUGRUPPE KAROSSERIE UND VERKLEIDUNG • CONJUNTO CARENADOS**E03**
1**ASSIEME AIRBOX**AIRBOX ASSEMBLY • ENSEMBLE AIRBOX
BAUGRUPPE AIRBOX • CONJUNTO AIRBOX**E04**
3**ASSIEME SERBATOIO BENZINA**FUEL TANK ASSEMBLY • ENSEMBLE RÉSERVOIR DE CARBURANT
BAUGRUPPE TANK • CONJUNTO DEPÓSITO GASOLINA**E05**
3**ASSIEME CODONE**REAR FAIRING ASSEMBLY • ENSEMBLE CARÉNAGE DE SELLE
BAUGRUPPE HECK • CONJUNTO COLÍN**F01**
4**IMPIANTO ELETTRICO**ELECTRIC SYSTEM • INSTALLATION ÉLECTRIQUE
ELEKTRISCHE ANLAGE • INSTALACIÓN ELÉCTRICA**F02**
1**PROIETTORE ANTERIORE**FRONT HEADLIGHT • PROJECTEUR AVANT
SCHEINWERFER • PROYECTOR DELANTERO**F03**
3**IMPIANTO ELETTRICO**ELECTRIC SYSTEM • INSTALLATION ÉLECTRIQUE
ELEKTRISCHE ANLAGE • INSTALACIÓN ELÉCTRICA**F04**
3**IMPIANTO ELETTRICO**ELECTRIC SYSTEM • INSTALLATION ÉLECTRIQUE
ELEKTRISCHE ANLAGE • INSTALACIÓN ELÉCTRICA**F05**
2**IMPIANTO ELETTRICO**ELECTRIC SYSTEM • INSTALLATION ÉLECTRIQUE
ELEKTRISCHE ANLAGE • INSTALACIÓN ELÉCTRICA**F06**
2**IMPIANTO ELETTRICO**ELECTRIC SYSTEM • INSTALLATION ÉLECTRIQUE
ELEKTRISCHE ANLAGE • INSTALACIÓN ELÉCTRICA



INDICE DESCRITTIVO

DESCRIPTIVE INDEX • INDEX DESCRIPTIF
BESCHREIBENDES INHALTSVERZEICHNIS • ÍNDICE DESCRIPTIVO

G01
2

ASSIEME CARTER MOTORE

CRANKCASE ASSEMBLY • ENSEMBLE CARTER DU MOTEUR
BAUGRUPPE MOTORGEHÄUSE • CONJUNTO CÁRTER MOTOR

G02
2

ASSIEME ALBERO MOTORE

CRANK SHAFT ASSEMBLY • ENSEMBLE VILEBREQUIN
BAUGRUPPE KURBELWELLE • CONJUNTO CIGÜEÑAL

G03
2

ASSIEME CILINDRI E PISTONI

CYLINDERS AND PISTONS ASSEMBLY • ENSEMBLE CYLINDRES ET PISTONS
BAUGRUPPE ZYLINDER UND KOLBEN • CONJUNTO CILINDROS Y PISTONES

G04
2

ASSIEME TESTATA

CYLINDER HEAD ASSEMBLY • ENSEMBLE CULASSE
BAUGRUPPE ZYLINDERKOPF • CONJUNTO CULATA

G05
2

DISTRIBUZIONE

TIMING SYSTEM • DISTRIBUTION
VENTILSTEUERUNG • DISTRIBUCIÓN

G06
2

LUBRIFICAZIONE

LUBRICATION SYSTEM • GRAISSAGE
SCHMIERSYSTEM • LUBRIFICACIÓN

G07
2

POMPA ACQUA

WATER PUMP • POMPE À EAU
WASSERPUMPE • BOMBA AGUA

G08
2

IMPIANTO DI RAFFREDDAMENTO

COOLING SYSTEM • CIRCUIT DE REFROIDISSEMENT
KÜHLSYSTEM • INSTALACIÓN DE REFRIGERACIÓN

G09
2

ASSIEME FRIZIONE (BRUTALE 990 R / BRUTALE MY 2011)

CLUTCH ASSEMBLY (B5 990 R / BRUTALE MY 2011) • ENSEMBLE EMBRAYAGE (B5 990 R / BRUTALE MY 2011)
BAUGRUPPE KUPPLUNG (B5 990 R / BRUTALE MY 2011) • CONJUNTO EMBRAGUE (B5 990 R / BRUTALE MY 2011)

G10
2

ASSIEME CAMBIO

CHANGE GEAR ASSEMBLY • ENSEMBLE BOÎTE DE VITESSE
BAUGRUPPE GETRIEBE • CONJUNTO CAMBIO

G11
3

SELETTORE CAMBIO

GEAR SELECTOR • SÉLECTEUR DE VITESSES
GANGSCHALTER • SELECTOR CAMBIO

G12
1

GRUPPO POMPA BENZINA

FUEL PUMP ASSEMBLY • GROUPE POMPE D'ALIMENTATION
BAUGRUPPE BENZINPUMPE • GRUPO BOMBA GASOLINA

G13
2

ALIMENTAZIONE MOTORE

FUEL SYSTEM • ALIMENTATION MOTEUR
MOTORVERSORGUNG • ALIMENTACIÓN MOTOR

G14
3

AVVIAMENTO

STARTING SYSTEM • DÉMARREUR
ANLASSERSYSTEM • PUESTA EN MARCHA



G15
3

IMPIANTO ELETTRICO MOTORE

ENGINE ELECTRIC SYSTEM • INSTALLATION ÉLECTRIQUE MOTEUR
 ELEKTRISCHE ANLAGE MOTOR • INSTALACIÓN ELÉCTRICA MOTOR

G16
4

IMPIANTO DI SCARICO

EXHAUST SYSTEM • ÉCHAPPEMENT
 ABGASANLAGE • INSTALACIÓN DE ESCAPE

G17
2

ASSIEME FRIZIONE (BRUTALE 1090 RR)

CLUTCH ASSEMBLY (BRUTALE 1090 RR) • ENSEMBLE EMBRAYAGE (BRUTALE 1090 RR)
 BAUGRUPPE KUPPLUNG (BRUTALE 1090 RR) • CONJUNTO EMBRAGUE (BRUTALE 1090 RR)

H01
2

DOTAZIONI

OUTFIT • ÉQUIPEMENT
 BORDWERKZEUG • EQUIPAMIENTO

J01
2

ATTREZZATURE DI SERVIZIO (CICLISTICA)

SERVICE TOOLS (FRAME) • MATÉRIEL (PARTIE CYCLE)
 SPEZIALWERKZEUG (RAHMEN) • UTILLAJE DE SERVICIO (MOTOCICLETA)

J02
2

ATTREZZATURE DI SERVIZIO (CICLISTICA)

SERVICE TOOLS (FRAME) • MATÉRIEL (PARTIE CYCLE)
 SPEZIALWERKZEUG (RAHMEN) • UTILLAJE DE SERVICIO (MOTOCICLETA)

J03
4

ATTREZZATURE DI SERVIZIO (MOTORE)

SERVICE TOOLS (ENGINE) • MATÉRIEL (MOTEUR)
 SPEZIALWERKZEUG (MOTOR) • UTILLAJE DE SERVICIO (MOTOR)

J04
3

ATTREZZATURE DI SERVIZIO (MOTORE)

SERVICE TOOLS (ENGINE) • MATÉRIEL (MOTEUR)
 SPEZIALWERKZEUG (MOTOR) • UTILLAJE DE SERVICIO (MOTOR)

K01
3

VARIANTI ESTERO

VERSIONS FOR FOREIGN COUNTRIES • VARIANTES ÉTRANGER
 MODELLVARIANTEN AUSLAND • VARIANTES EXTRANJERO

K02
1

ASSIEME CANISTER

CARBON CANISTER ASSEMBLY • ENSEMBLE CANISTER
 BAUGRUPPE CARBONKANISTER • CONJUNTO CANISTER

Z01
5

INDICE CODICI / DENOMINAZIONI

CODIX / DESIGNATION INDEX • INDEX CODES / DÉNOMINATIONS
 INHALTSVERZEICHNIS CODE • ÍNDICE CÓDIGOS / DENOMINACIONES



INDICE FIGURATIVO

FIGURATIVE INDEX • INDEX FIGURATIF
BILDVERZEICHNIS • ÍNDICE DE FIGURAS

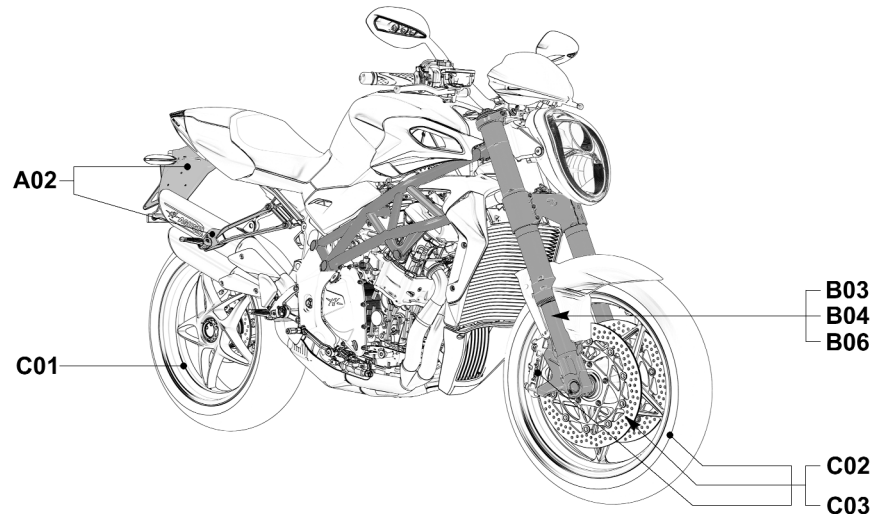
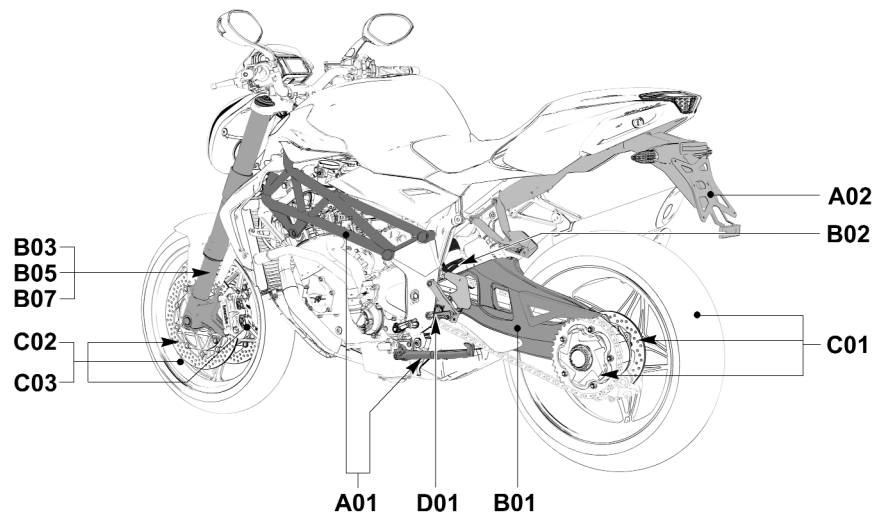
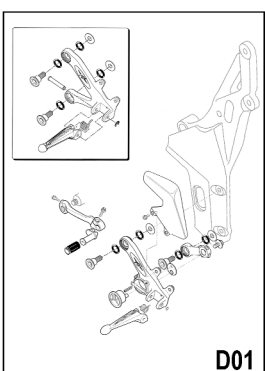
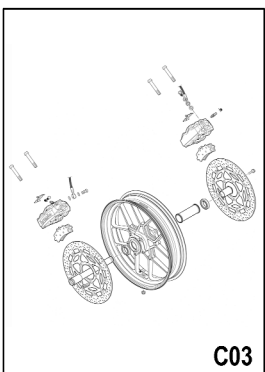
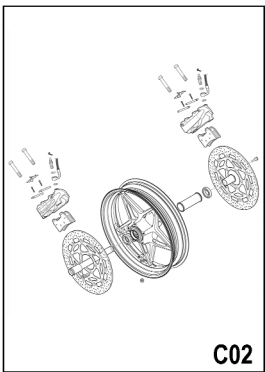
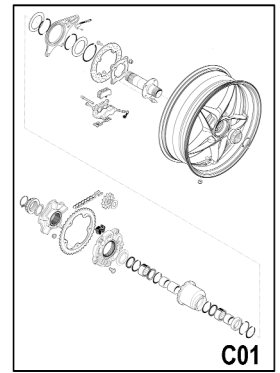
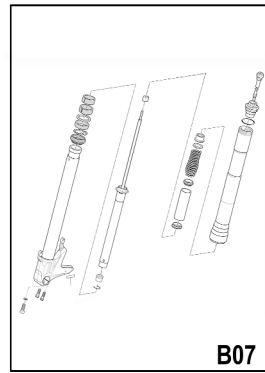
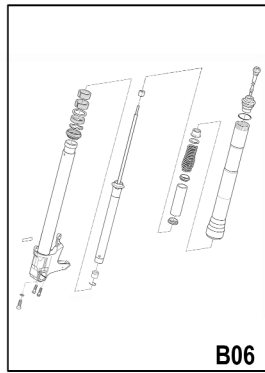
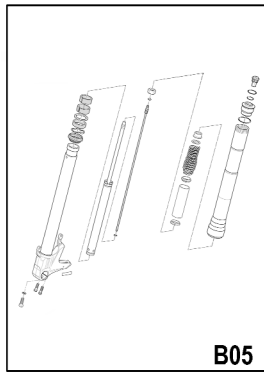
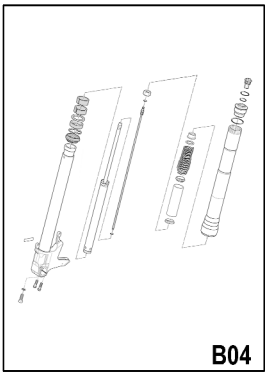
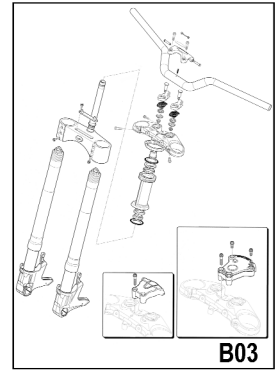
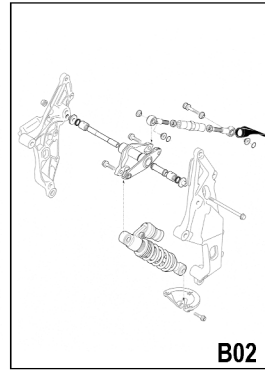
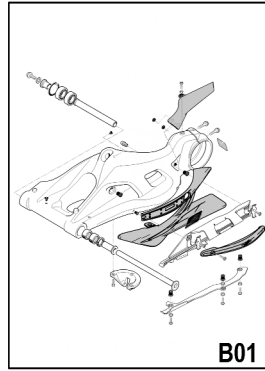
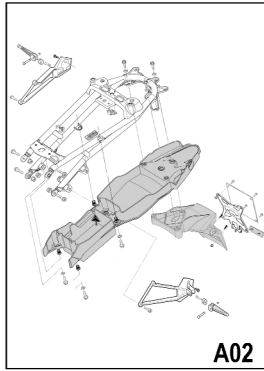
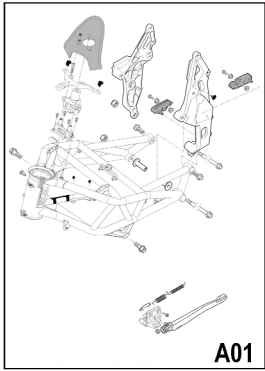

INDICE FIGURATIVO

FIGURATIVE INDEX • INDEX FIGURATIF
BILDVERZEICHNIS • ÍNDICE DE FIGURAS

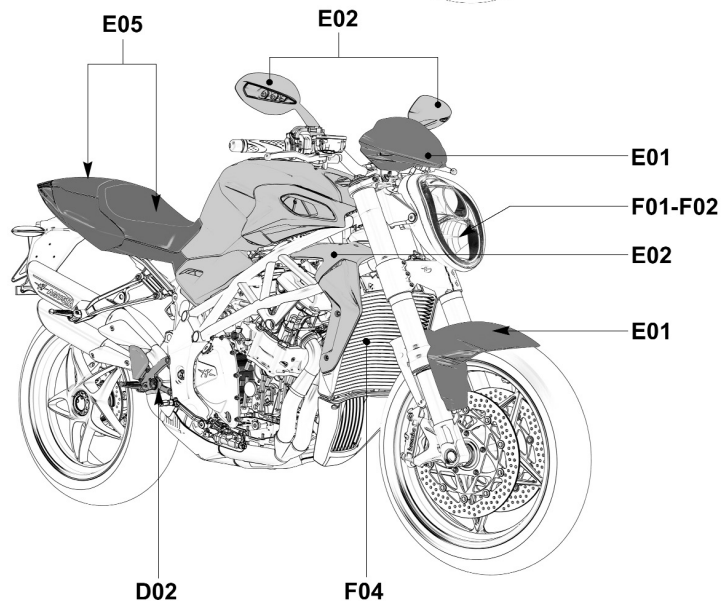
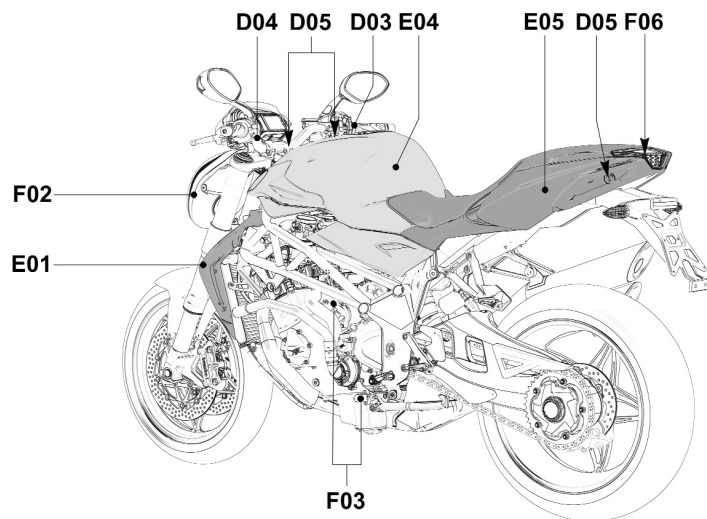
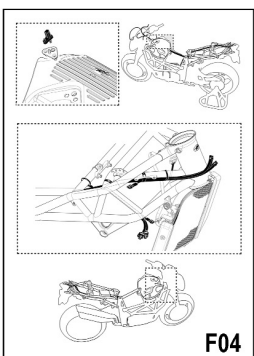
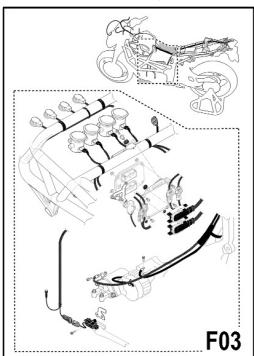
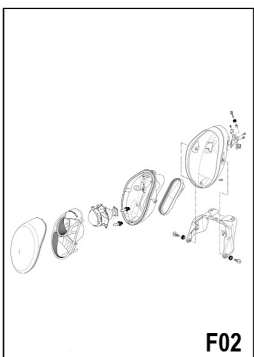
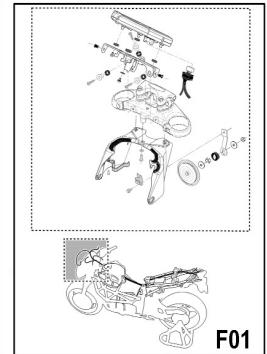
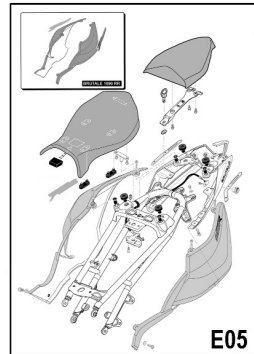
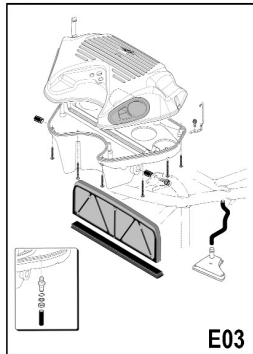
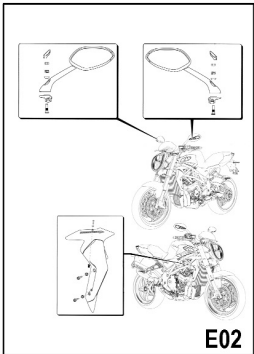
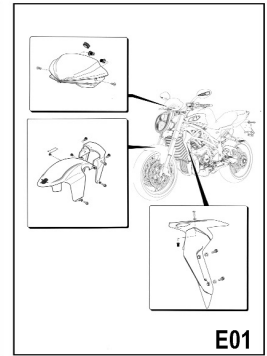
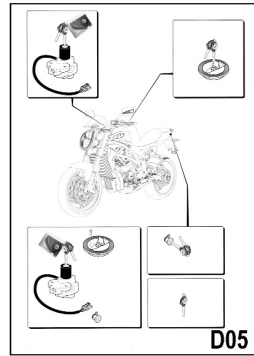
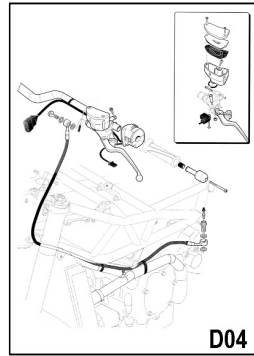
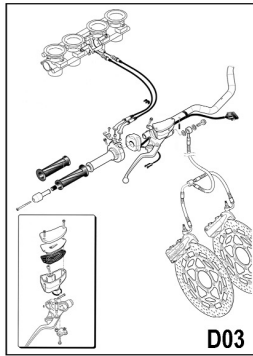
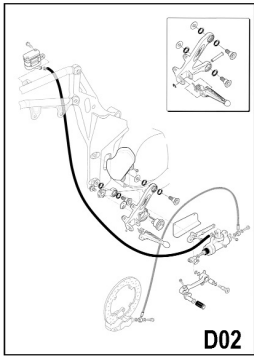



INDICE FIGURATIVO

FIGURATIVE INDEX • INDEX FIGURATIF
BILDVERZEICHNIS • ÍNDICE DE FIGURAS

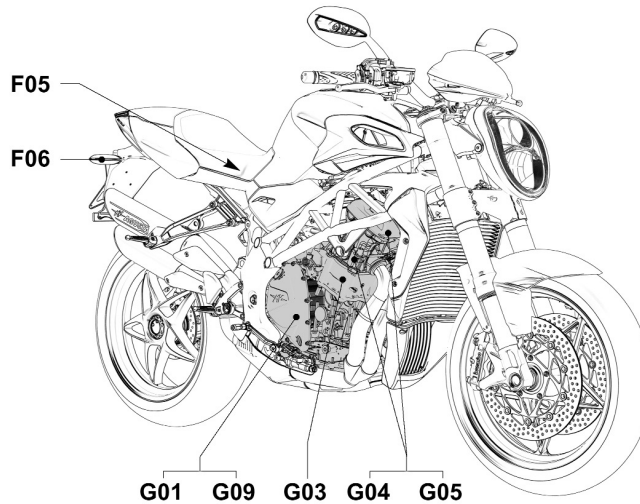
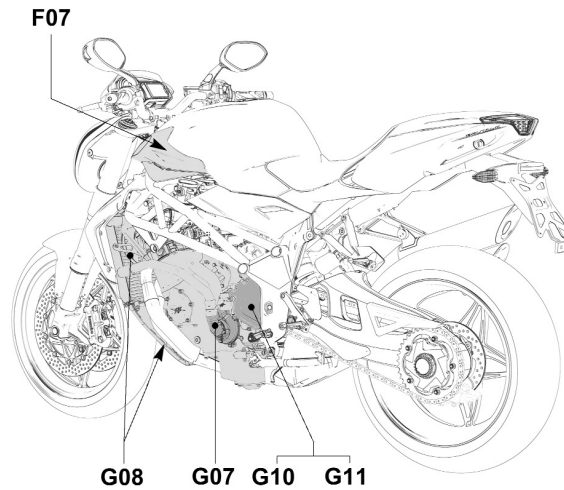
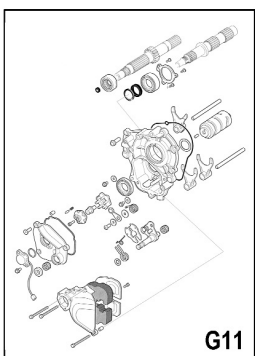
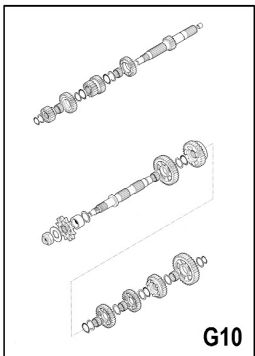
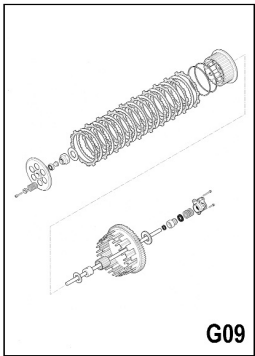
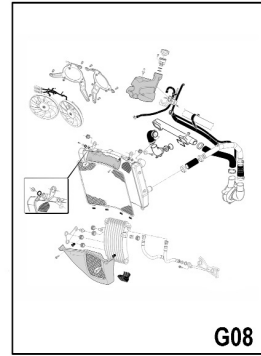
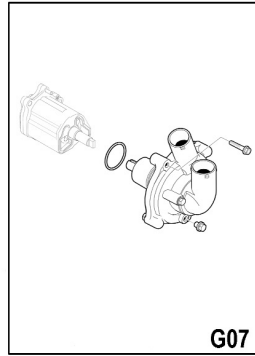
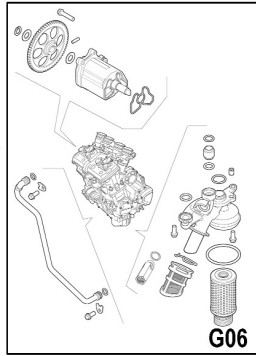
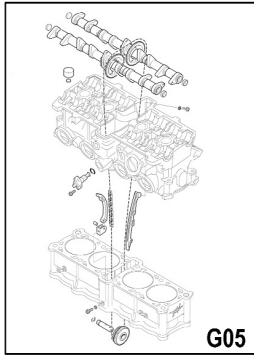
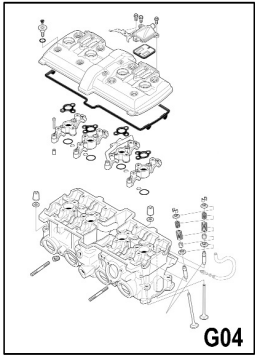
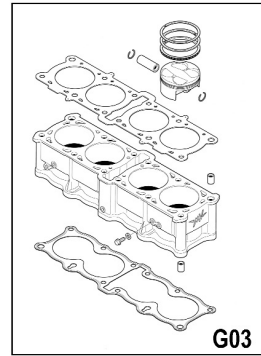
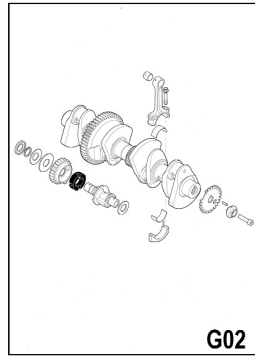
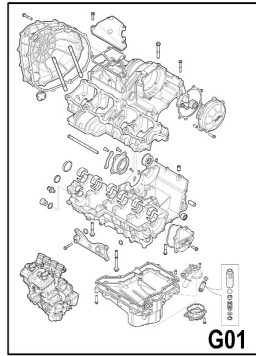
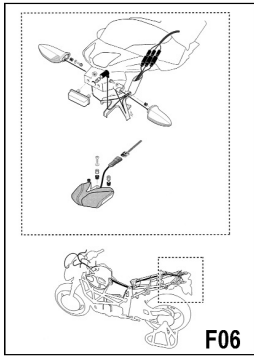
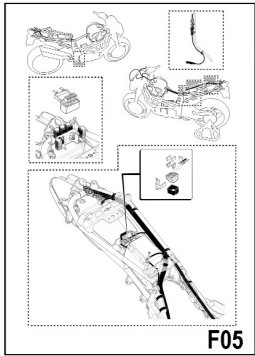

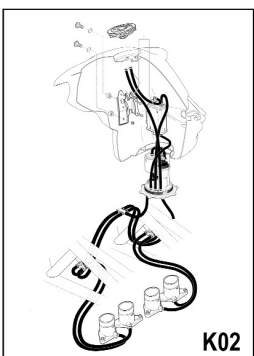
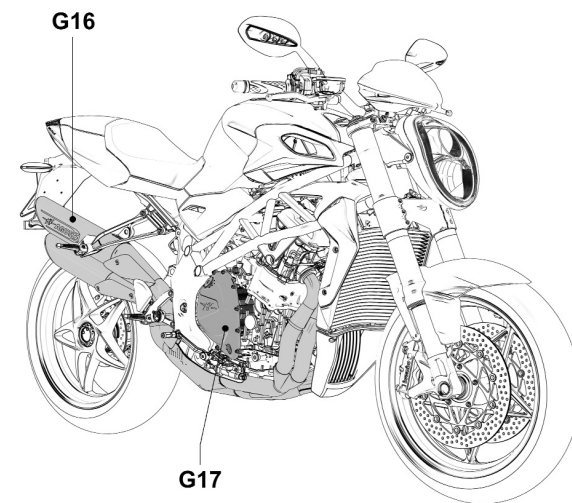
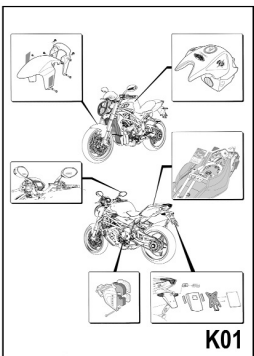
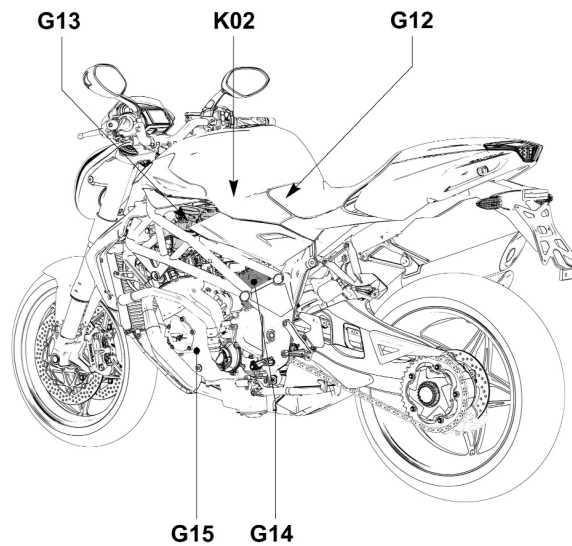
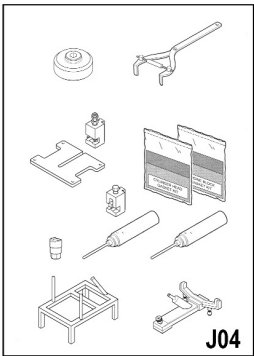
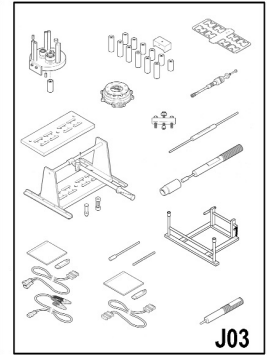
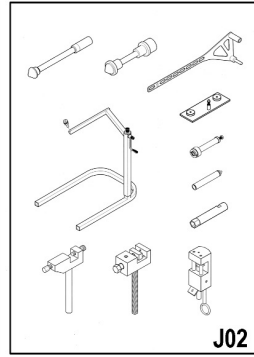
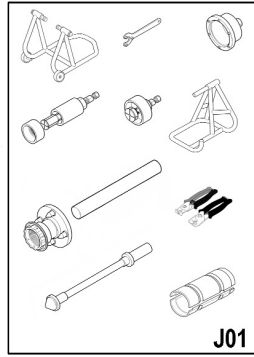
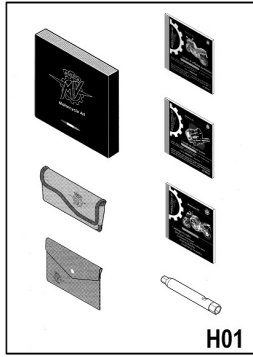
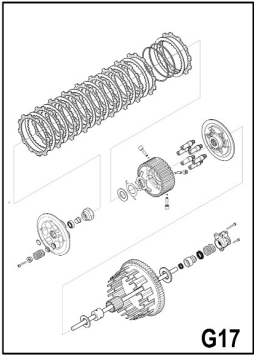
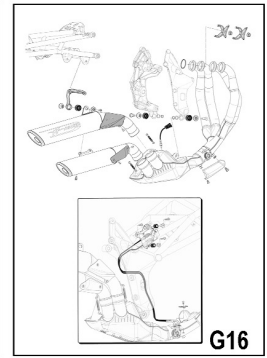
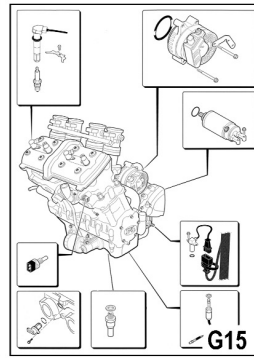
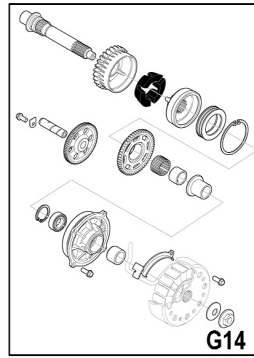
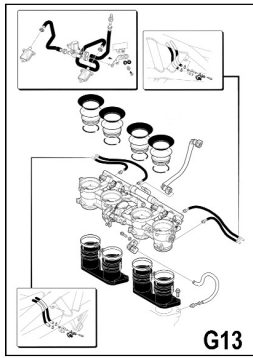
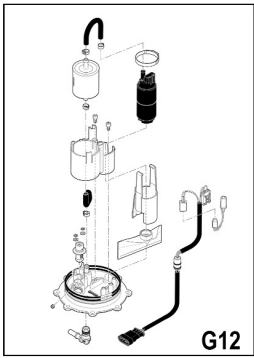



ASSIEME TELAIO
FRAME ASSEMBLY • ENSEMBLE CADRE
BAUGRUPPE RAHMEN • CONJUNTO BASTIDOR

Brutale 990 R / 1090 RR

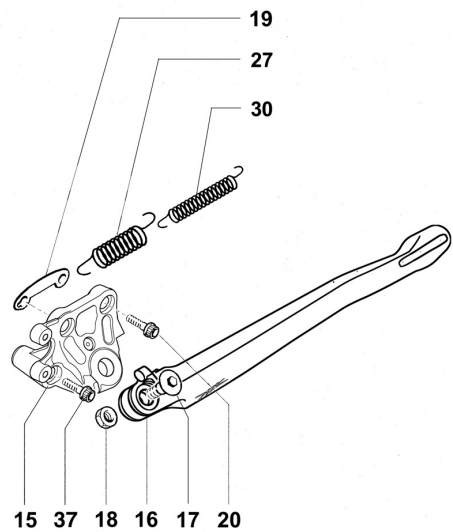
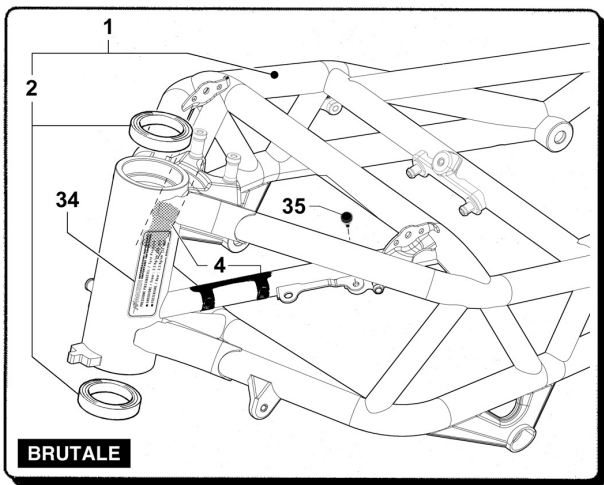
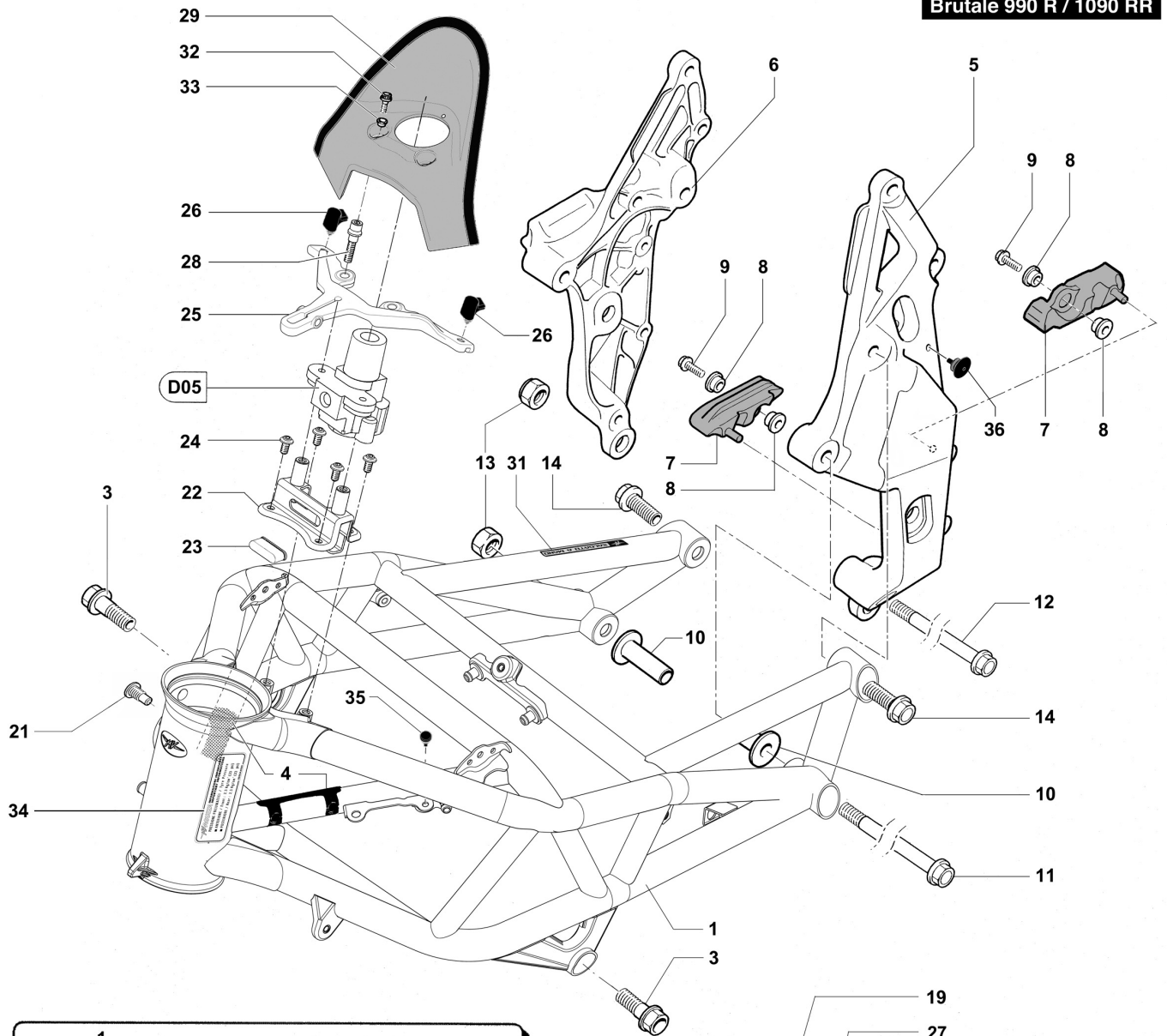

ASSIEME TELAIO

 FRAME ASSEMBLY • ENSEMBLE CADRE
 BAUGRUPPE RAHMEN • CONJUNTO BASTIDOR

N.	Code	Q.ty	Note	Brutale 990 R	Brutale 1090 RR	Brutale	► I FRAME I ►	► I ENGINE I ►
1	80A0B2993	1		.				
1	80A0B2993	1	A B C		.			
1	80B0B2993	1	D E		.			
1	80C0B2993	1	F		.			
1	80D0B4589	1				.		
2	8000B4784	2				.		
3	8000B3004	2		.	.	.		
4	800090417	2		.	.	.		
5	80A0B3977	1		.				
5	80B0B3977	1			.	.		
6	80A0B3976	1		.				
6	80B0B3976	1			.	.		
7	8000B3978	2		.	.	.		
8	80A090392	4		.	.	.		
9	8E00B2681	2		.	.	.		
10	8AA084857	2		.	.	.		
11	8000B2757	1		.	.	.		
12	8000B2756	1		.	.	.		
13	8000B2715	2		.	.	.		
14	8000B2750	2		.	.	.		
15	8000B3974	1		.	.	.		
16	8000B3583	1		.	.	.		
17	80A090431	1		.	.	.		
18	80A090432	1		.	.	.		
19	8000B3584	1		.	.	.		
20	8B00B2690	2		.	.	.		
21	800084915	1		.	.	.		
22	8000B2979	1		.	.	.		
23	800099426	1		.	.	.		
24	8A00B2672	4		.	.	.		
25	8000B3085	1		.	.	.		
26	8000B2992	2		.	.	.		
27	8000B3987	1		.	.	.		
28	8000B2991	2		.	.	.		
29	8000B2984	1		.	.	.		
30	8000B3986	1		.	.	.		
31	8000B4203	1		.	.	.		
32	8C00B2687	2		.	.	.		
33	80A092658	2		.	.	.		
34	8000A4000	1	1	.	.	.		
35	800099419	2		.	.	.		
36	8000B4014	1		.	.	.	► I 001805	
37	8D00B2690	1		.	.	.		

1 Esclusi gli USA - USA excluded - Sauf les USA - Ausschließlich USA - Excluidos los USA.

B5 1090 RR: **A D** Versione Rosso/Argento - Red/Silver version - Version Rouge/Argent - Rot/Silber Version - Versión Rojo/Plata.

B E Versione Bianco/Nero - White/Black version - Version Blanche/Noire - Weiße/Schwarze Version - Versión Blanca/Negra.

C Versione Nero/Antracite - Black/Anthracite version - Version Noire/Anthracite - Schwarze/Anthrazit Version - Versión Negra/Antracita.

F Versione Argento/Grigio Titanium - Silver/Titanium Grey version - Version Argent/Gris Titanium - Silber/Grau Titanium Version - Versión Plata/Gris Titanium.

A01

3



ASSIEME TELAIO POSTERIORE

REAR FRAME ASSEMBLY • ENSEMBLE CADRE ARRIÈRE

BAUGRUPPE HINTERER RAHMEN • CONJUNTO BASTIDOR TRASERO

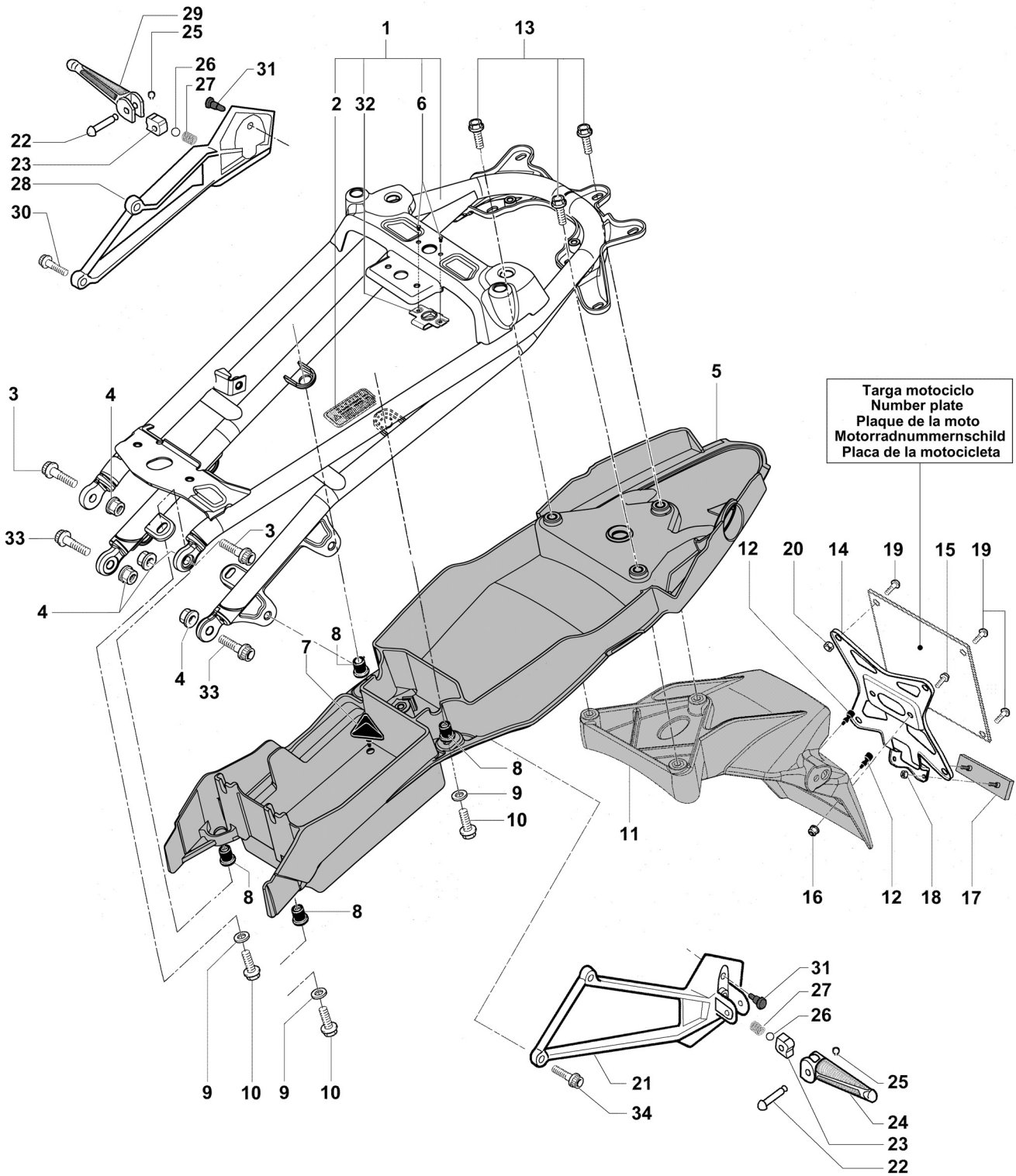

ASSIEME TELAIO POSTERIORE

REAR FRAME ASSEMBLY • ENSEMBLE CADRE ARRIÈRE

BAUGRUPPE HINTERER RAHMEN • CONJUNTO BASTIDOR TRASERO



N.	Code	Q.ty	Note	Brutale 990 R	Brutale 1090 RR	Brutale	► I FRAME I ►	► I ENGINE I ►
1	8000B3147	1		•	•			
1	8000B4770	1				•		
2	800092257	1		•	•	•		
3	8D00B2690	2		•	•	•		
4	8000B2712	4		•	•	•		
5	8000B2986	1		•	•	•		
6	800094279	2		•	•			
7	800066339	4		•	•	•		
8	800048245	4		•	•	•		
9	800089751	4		•	•	•		
10	8B00B2672	4		•	•	•		
11	8A0099120	1		•	•	•		
12	800099419	2	①	•	•	•		
13	8E00B2681	3		•	•	•		
14	8000B3982	1	①	•	•	•		
15	8B00B2681	2	②	•	•	•		
16	8000B2710	2		•	•	•		
17	800090374	1		•	•	•		
18	8000B2706	2		•	•	•		
19	8000B2673	4		•	•	•		
20	8000B2706	4		•	•	•		
21	80B094169	1		•	•	•		
22	8B00B2769	2		•	•	•		
23	800094171	2		•	•	•		
24	80A091661	1		•	•	•		
25	800090429	2		•	•	•		
26	6BN021507	2		•	•	•		
27	800094170	2		•	•	•		
28	80B098721	1		•	•	•		
29	80A091662	1		•	•	•		
30	8D00B2690	2		•	•	•		
31	800095828	2		•	•	•		
32	800069150	1		•	•			
33	8C00B2690	2		•	•	•		
34	8B00B2690	2		•	•	•		

① Esclusi gli USA (vedi tavola K01) - USA excluded (see table K01) - Sauf les USA (voir planche K01) - Ausschließlich USA (siehe Tafel K01) - Excluidos los USA (ver tabla K01).

② Esclusa l'Australia (vedi tavola K01) - Australia excluded (see table K01) - Sauf l'Australie (voir planche K01) - Ausschließlich Australien (siehe Tafel K01) - Excluida la Australia (ver tabla K01).



ASSIEME FORCELLONE
SWINGING ARM ASSEMBLY • ENSEMBLE FOURCHE
BAUGRUPPE GABEL • CONJUNTO HORQUILLA

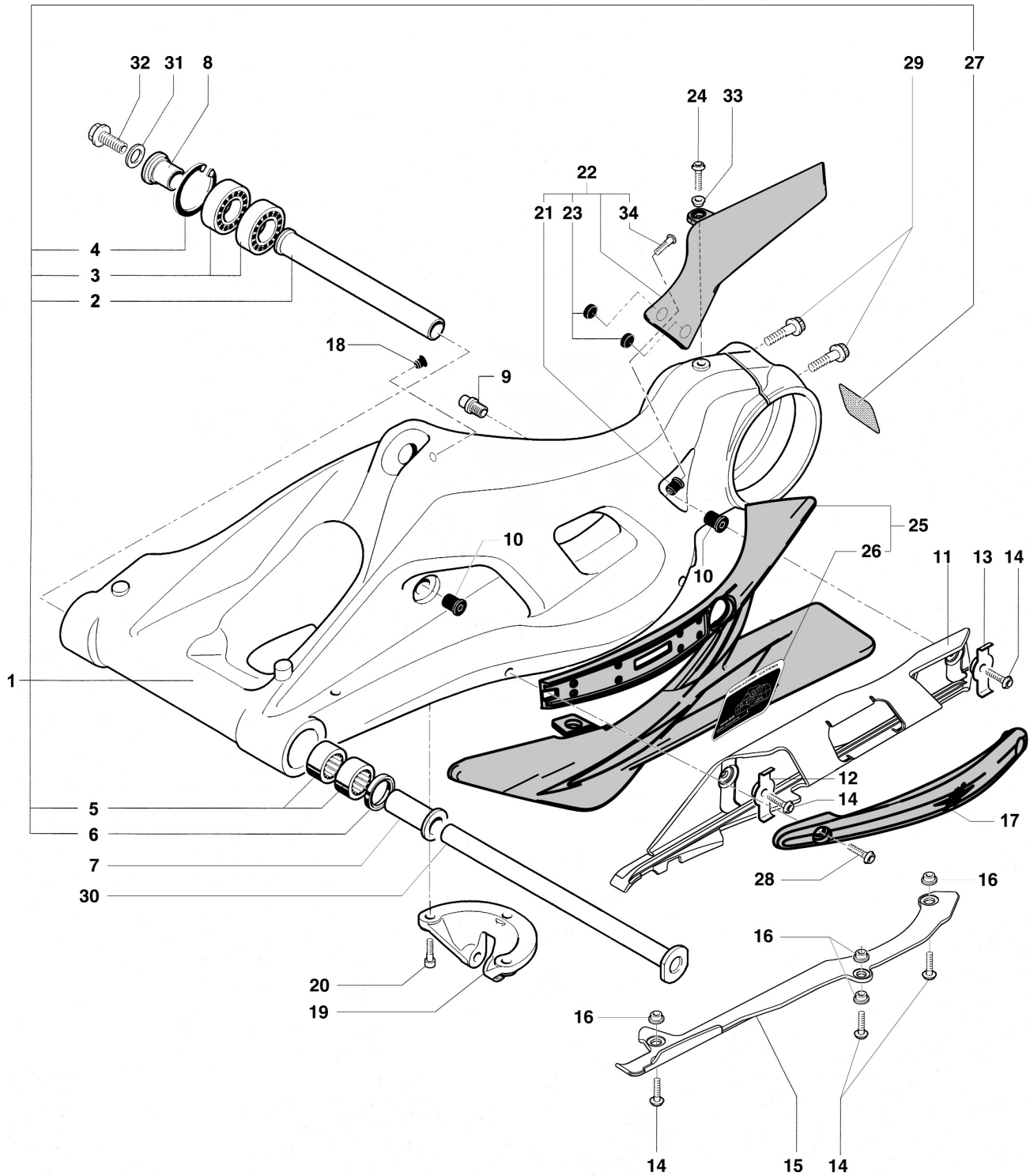

ASSIEME FORCELLONE

 SWINGING ARM ASSEMBLY • ENSEMBLE FOURCHE
 BAUGRUPPE GABEL • CONJUNTO HORQUILLA



N.	Code	Q.ty	Note	Brutale 990 R	Brutale 1090 RR	Brutale	► I FRAME I ►	► I ENGINE I ►
1	8A00B3614	1		•				
1	8AA0B3614	1			•	•		
2	800084872	1		•	•	•		
3	800084938	2		•	•	•		
4	800084939	1		•	•	•		
5	800084936	2		•	•	•		
6	800084937	1		•	•	•		
7	800084859	1		•	•	•		
8	800084873	1		•	•	•		
9	8000B2762	1		•	•	•		
10	800048245	2		•	•	•		
11	8000B3622	1		•	•	•		
12	800087463	1		•	•	•		
13	800089300	1		•	•	•		
14	8B00B2672	5		•	•	•		
15	8000B3623	1		•	•	•		
16	800090391	4		•	•	•		
17	8000B3629	1		•	•	•		
18	8000A4539	3		•	•	•		
19	800087441	1		•	•	•		
20	8D00B2691	3		•	•	•		
21	800091022	1		•	•	•		
22	8000B5319	1		•	•	•		
23	800090979	2		•	•	•		
24	8A00B2672	1		•	•	•		
25	8000B4016	1		•	•	•		
26	8000B4015	1		•	•	•		
27	8000A2734	1		•	•	•		
28	8B00B2688	2		•	•	•		
29	8000B2752	2		•	•	•		
30	800091655	1		•	•	•		
31	8000B2728	1		•	•	•		
32	8000B2751	1		•	•	•		
33	80A090392	1		•	•	•		
34	8A0090901	1		•	•	•		



ASSIEME SOSPENSIONE POSTERIORE

REAR SUSPENSION ASSEMBLY • ENSEMBLE SUSPENSION ARRIÈRE

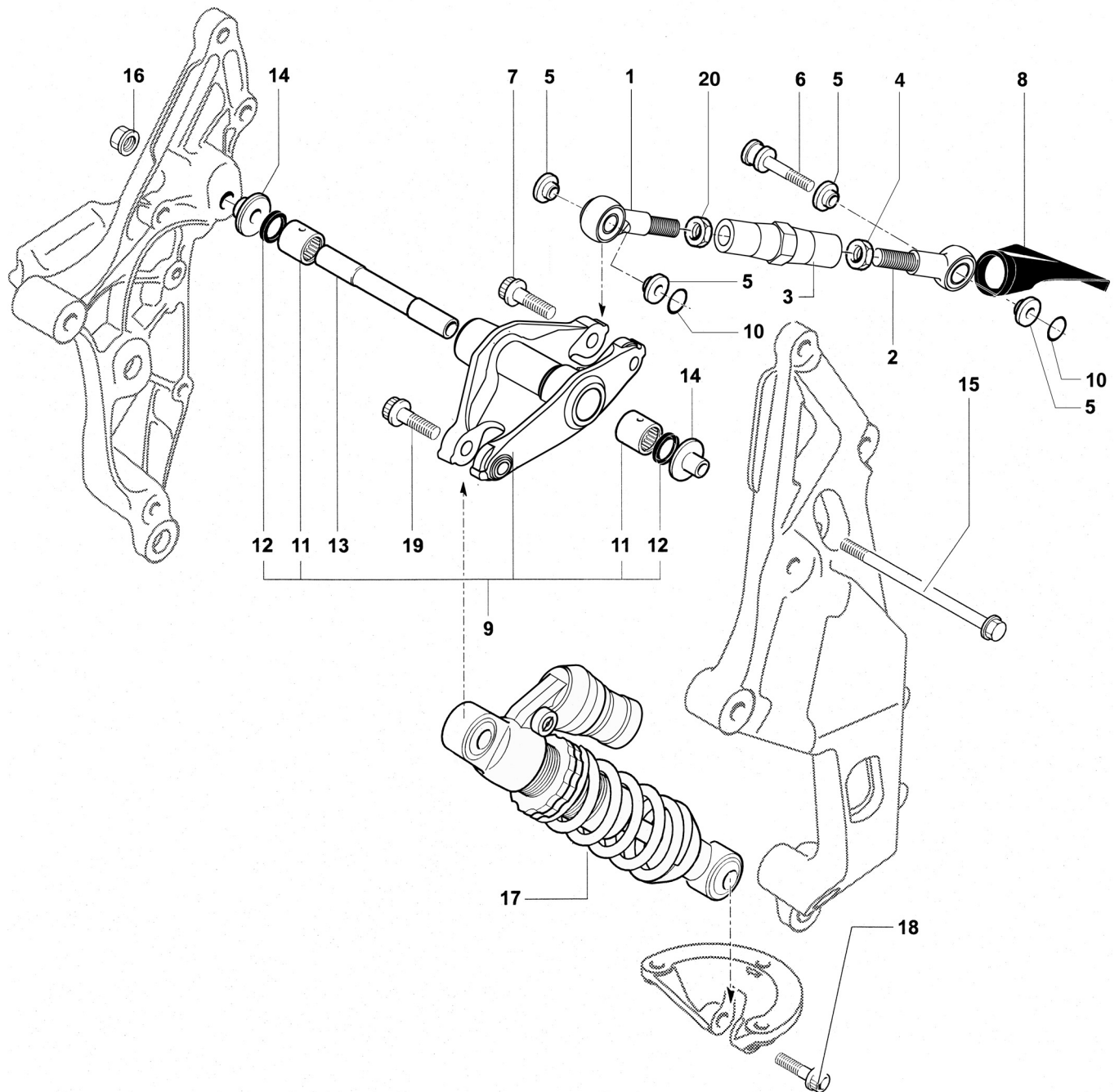
BAUGRUPPE HINTERRADAUFHÄNGUNG • CONJUNTO SUSPENSIÓN TRASERA



ASSIEME SOSPENSIONE POSTERIORE

REAR SUSPENSION ASSEMBLY • ENSEMBLE SUSPENSION ARRIÈRE

BAUGRUPPE HINTERRADAUFHÄNGUNG • CONJUNTO SUSPENSIÓN TRASERA



N.	Code	Q.ty	Note	Brutale 990 R	Brutale 1090 RR	Brutale	► I FRAME I ►	► I ENGINE I ►
1	8000B3158	1		•	•	•		
2	8A00B3158	1		•	•	•		
3	8000B3157	1		•	•	•		
4	8A00B3159	1		•	•	•		
5	8000B3160	4		•	•	•		
6	8000B2763	1		•	•	•		
7	8G00B2691	1		•	•	•		
8	800091027	1		•	•	•		
9	8000B3980	1		•	•	•		
10	8000B3491	2		•	•	•		
11	800084945	2		•	•	•		
12	800084946	2		•	•	•		
13	800084858	1		•	•	•		
14	80A086447	2		•	•	•		
15	8000B2755	1		•	•	•		
16	8000B2714	1		•	•	•		
17	8000B3984	1		•		•		
17	8000B3985	1			•			
18	8J00B2691	1		•	•	•		
19	8H00B2691	1		•	•	•		
20	8000B3159	1		•	•	•		



ASSIEME SOSPENSIONE ANTERIORE

FRONT SUSPENSION ASSEMBLY • ENSEMBLE SUSPENSION AVANT

BAUGRUPPE VORDERRADAUFHÄNGUNG • CONJUNTO SUSPENSIÓN DELANTERA

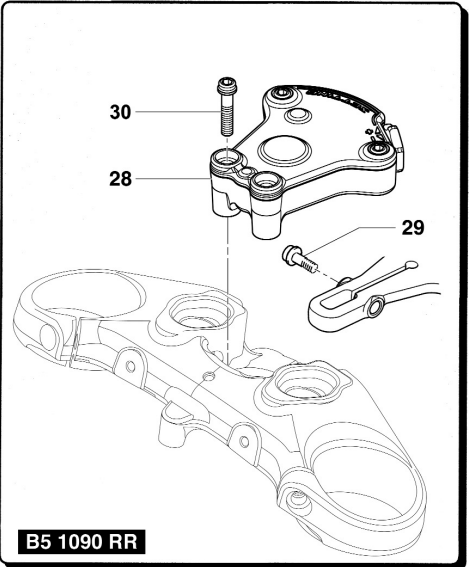
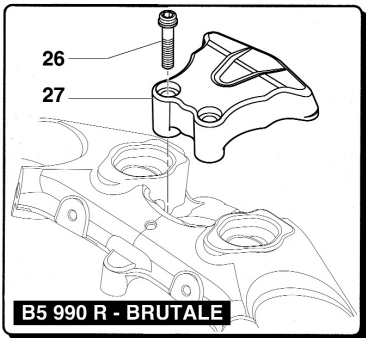
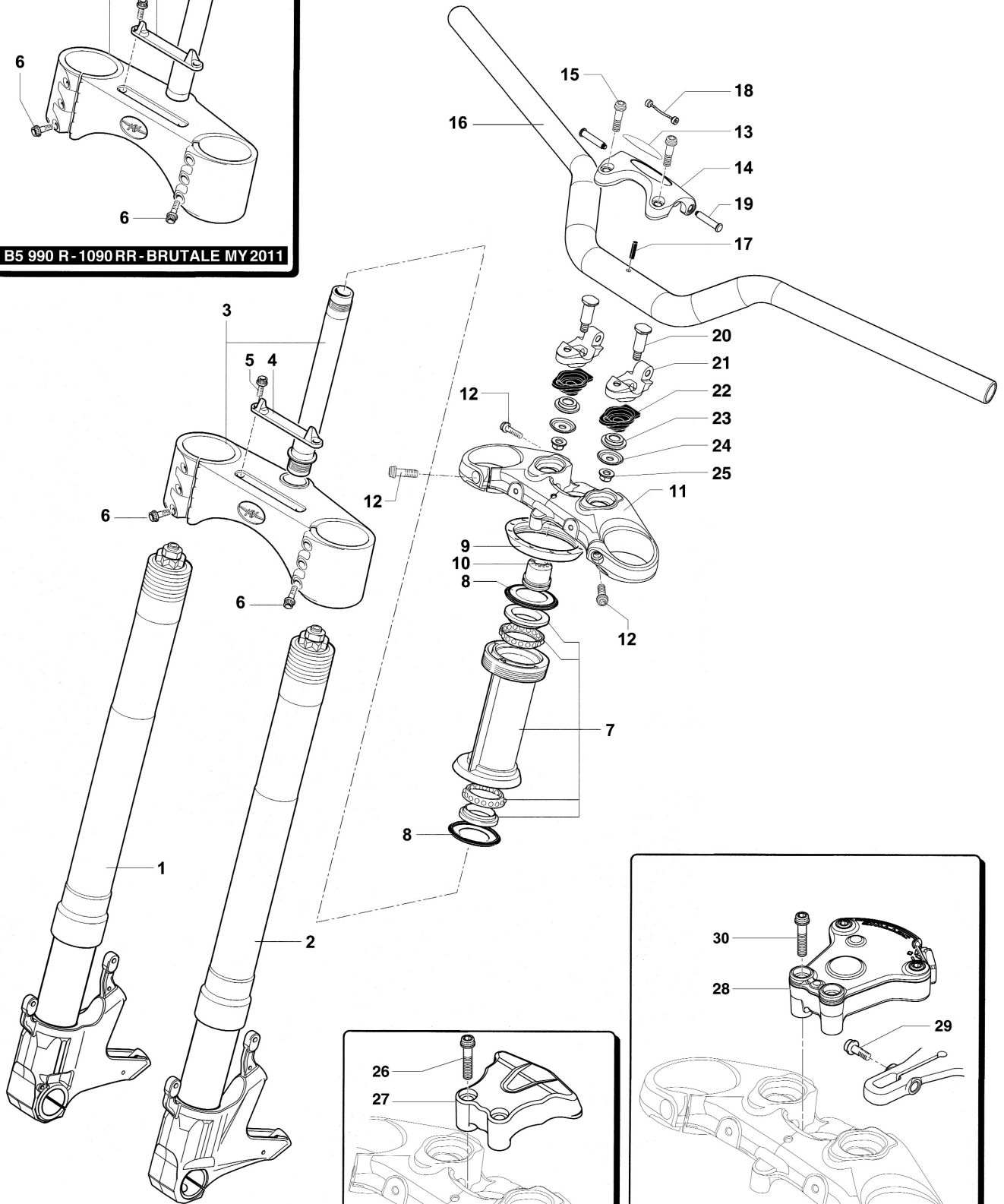
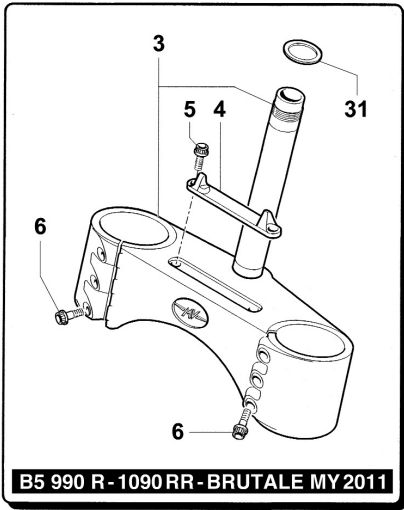

ASSIEME SOSPENSIONE ANTERIORE

FRONT SUSPENSION ASSEMBLY • ENSEMBLE SUSPENSION AVANT

BAUGRUPPE VORDERRADAUFHÄNGUNG • CONJUNTO SUSPENSIÓN DELANTERA



N.	Code	Q.ty	Note	Brutale 990 R	Brutale 1090 RR	Brutale	► I FRAME I ►	► I ENGINE I ►
1	8AA0B2514	1		•		•		
1	8B00B2158	1			•			
2	8AA0B2515	1		•		•		
2	8B00B2157	1			•			
3	8000B3340	1	MY 2010	•				
3	8000B4679	1	MY 2011	•		•		
3	80A0B3340	1	MY 2010		•			
3	80A0B4679	1	MY 2011		•			
4	8000B3090	1		•	•	•		
5	8B00B2688	2		•	•	•		
6	8E00B2688	6		•	•	•		
7	8B0090279	1		•	•			
8	800090897	2		•	•	•		
9	800086436	1		•	•			
10	8000B2982	1		•	•	•		
11	8000B3003	1		•	•	•		
12	8C00B2690	3		•	•	•		
13	8000B3154	1		•				
13	8000B3461	1			•			
13	8000B4982	1				•		
14	8000B3086	1		•	•	•		
15	8D00B2690	2		•	•	•		
16	8000B2978	1		•	•	•		
17	6AND55037	1		•	•	•		
18	800090906	1		•	•	•		
19	8000B3000	2		•	•	•		
20	8000B3114	2		•	•	•		
21	8000B2990	2		•	•	•		
22	8000B3440	2		•	•	•		
23	8000B3441	2		•	•	•		
24	8000B3474	2		•	•	•		
25	8000B2712	2		•	•	•		
26	8G00B2688	2		•		•		
27	8000B3155	1		•		•		
28	8000B3191	1			•			
29	8D00B2687	1			•			
30	8H00B2688	2			•			
31	8000B4363	1	MY 2011	•	•	•		



FORCELLA DESTRA (B5 990 R / BRUTALE MY 2011)

RIGHT-HAND FORK (B5 990 R / BRUTALE MY 2011) • FOURCHE DROITE (B5 990 R / BRUTALE MY 2011)
RECHTE GABEL (B5 990 R / BRUTALE MY 2011) • HORQUILLA DERECHA (B5 990 R / BRUTALE MY 2011)

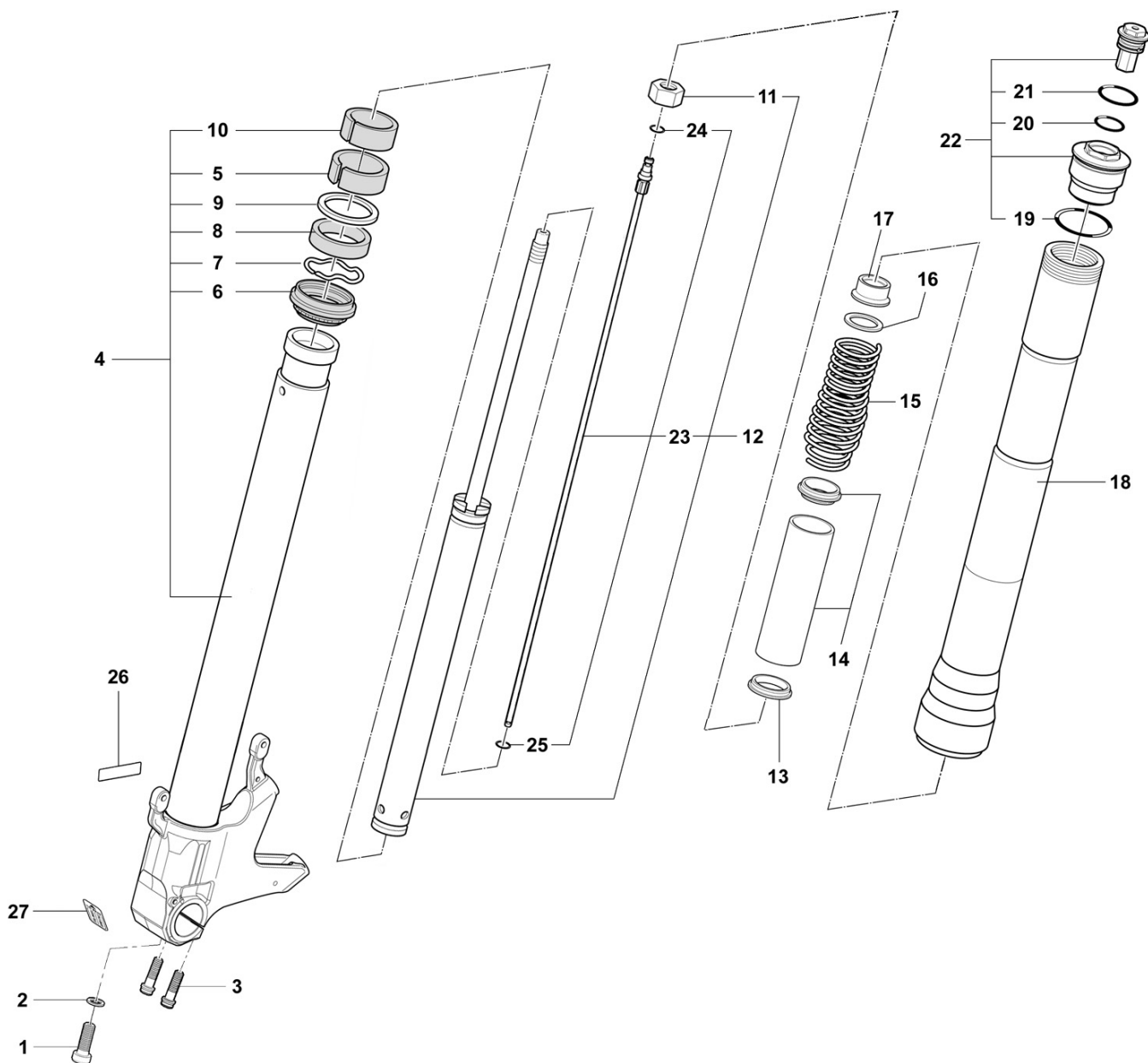

FORCELLA DESTRA (B5 990 R / BRUTALE MY 2011)RIGHT-HAND FORK (B5 990 R / BRUTALE MY 2011) • FOURCHE DROITE (B5 990 R / BRUTALE MY 2011)
RECHTE GABEL (B5 990 R / BRUTALE MY 2011) • HORQUILLA DERECHA (B5 990 R / BRUTALE MY 2011)

N.	Code	Q.ty	Note	Brutale 990 R	Brutale 1090 RR	Brutale	► I FRAME I ►	► I ENGINE I ►
1	800097784	1		•		•		
2	800046511	1		•		•		
3	8000B2689	2		•		•		
4	8A00B2132	1		•		•		
5	8000A1860	1		•		•		
6	8000A4690	1		•		•		
7	800089274	1		•		•		
8	800086500	1		•		•		
9	800089275	1		•		•		
10	800086503	1		•		•		
11	800081174	1		•		•		
12	8000B4258	1		•		•		
13	8000A1863	1		•		•		
14	8000B2518	1		•		•		
15	8000B2137	1		•		•		
16	8000A1867	1		•		•		
17	8000A1868	1		•		•		
18	8000B4261	1		•		•		
19	8000A1870	1		•		•		
20	800023118	1		•		•		
21	8000B2548	1		•		•		
22	8000B4262	1		•		•		
23	8000B4260	1		•		•		
24	8000A0817	1		•		•		
25	800023105	1		•		•		
26	8000A8286	1		•		•		
27	8000B4628	1		•		•		



FORCELLA SINISTRA (B5 990 R / BRUTALE MY 2011)

LEFT-HAND FORK (B5 990 R / BRUTALE MY 2011) • FOURCHE GAUCHE (B5 990 R / BRUTALE MY 2011)
LINKE GABEL (B5 990 R / BRUTALE MY 2011) • HORQUILLA IZQUIERDA (B5 990 R / BRUTALE MY 2011)

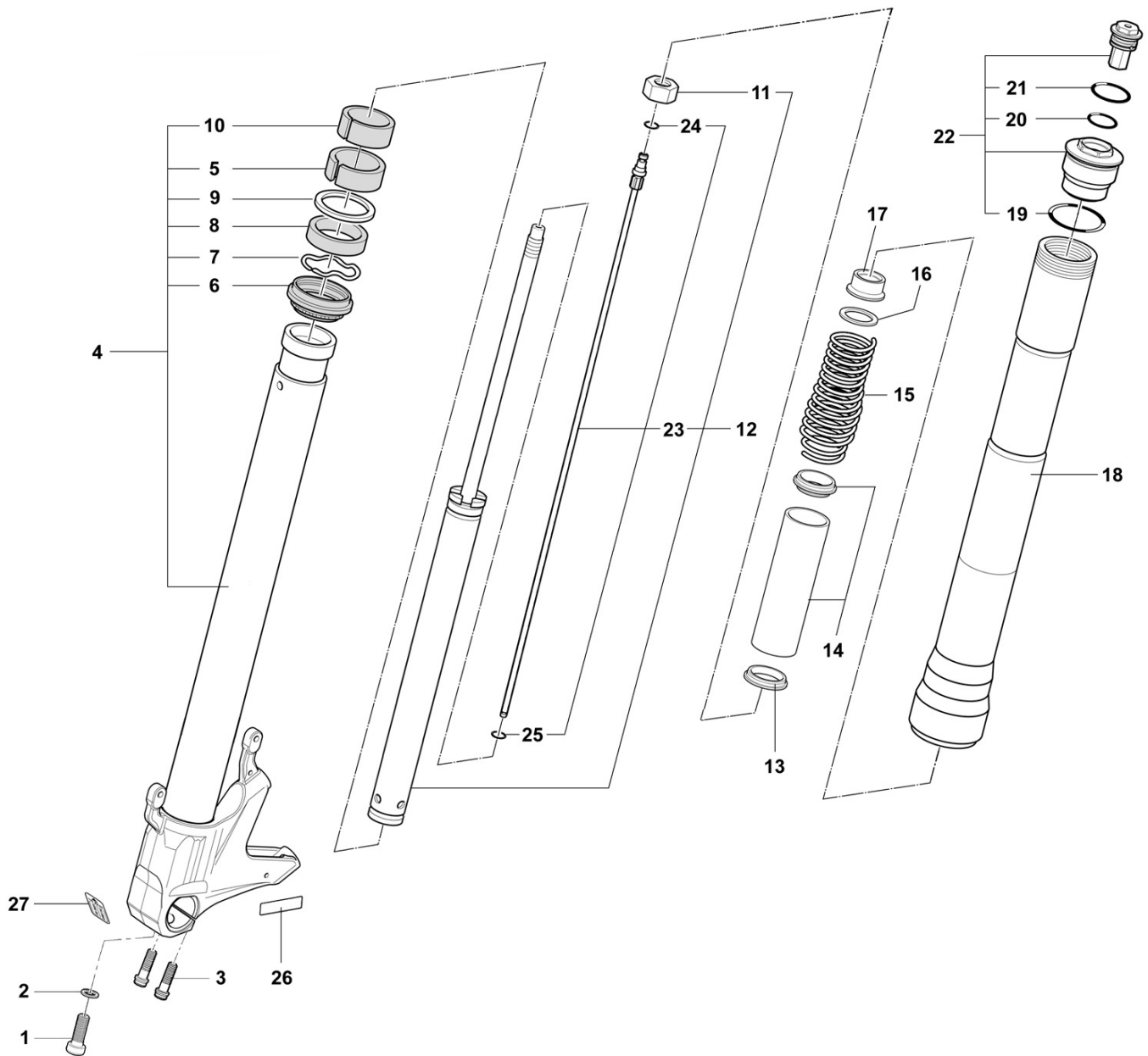

FORCELLA SINISTRA (B5 990 R / BRUTALE MY 2011)LEFT-HAND FORK (B5 990 R / BRUTALE MY 2011) • FOURCHE GAUCHE (B5 990 R / BRUTALE MY 2011)
LINKE GABEL (B5 990 R / BRUTALE MY 2011) • HORQUILLA IZQUIERDA (B5 990 R / BRUTALE MY 2011)

N.	Code	Q.ty	Note	Brutale 990 R	Brutale 1090 RR	Brutale	► I FRAME I ►	► I ENGINE I ►
1	800097784	1		•		•		
2	800046511	1		•		•		
3	8000B2689	2		•		•		
4	8A00B2131	1		•		•		
5	8000A1860	1		•		•		
6	8000A4690	1		•		•		
7	800089274	1		•		•		
8	800086500	1		•		•		
9	800089275	1		•		•		
10	800086503	1		•		•		
11	800081174	1		•		•		
12	8000B4259	1		•		•		
13	8000A1863	1		•		•		
14	8000B2518	1		•		•		
15	8000B2137	1		•		•		
16	8000A1867	1		•		•		
17	8000A1868	1		•		•		
18	8000B4261	1		•		•		
19	8000A1870	1		•		•		
20	800023118	1		•		•		
21	8000B2548	1		•		•		
22	8A00B4262	1		•		•		
23	8000B4260	1		•		•		
24	8000A0817	1		•		•		
25	800023105	1		•		•		
26	8000A8286	1		•		•		
27	8000B4628	1		•		•		



FORCELLA DESTRA (BRUTALE 1090 RR)

RIGHT-HAND FORK (BRUTALE 1090 RR) • FOURCHE DROITE (BRUTALE 1090 RR)
RECHTE GABEL (BRUTALE 1090 RR) • HORQUILLA DERECHA (BRUTALE 1090 RR)

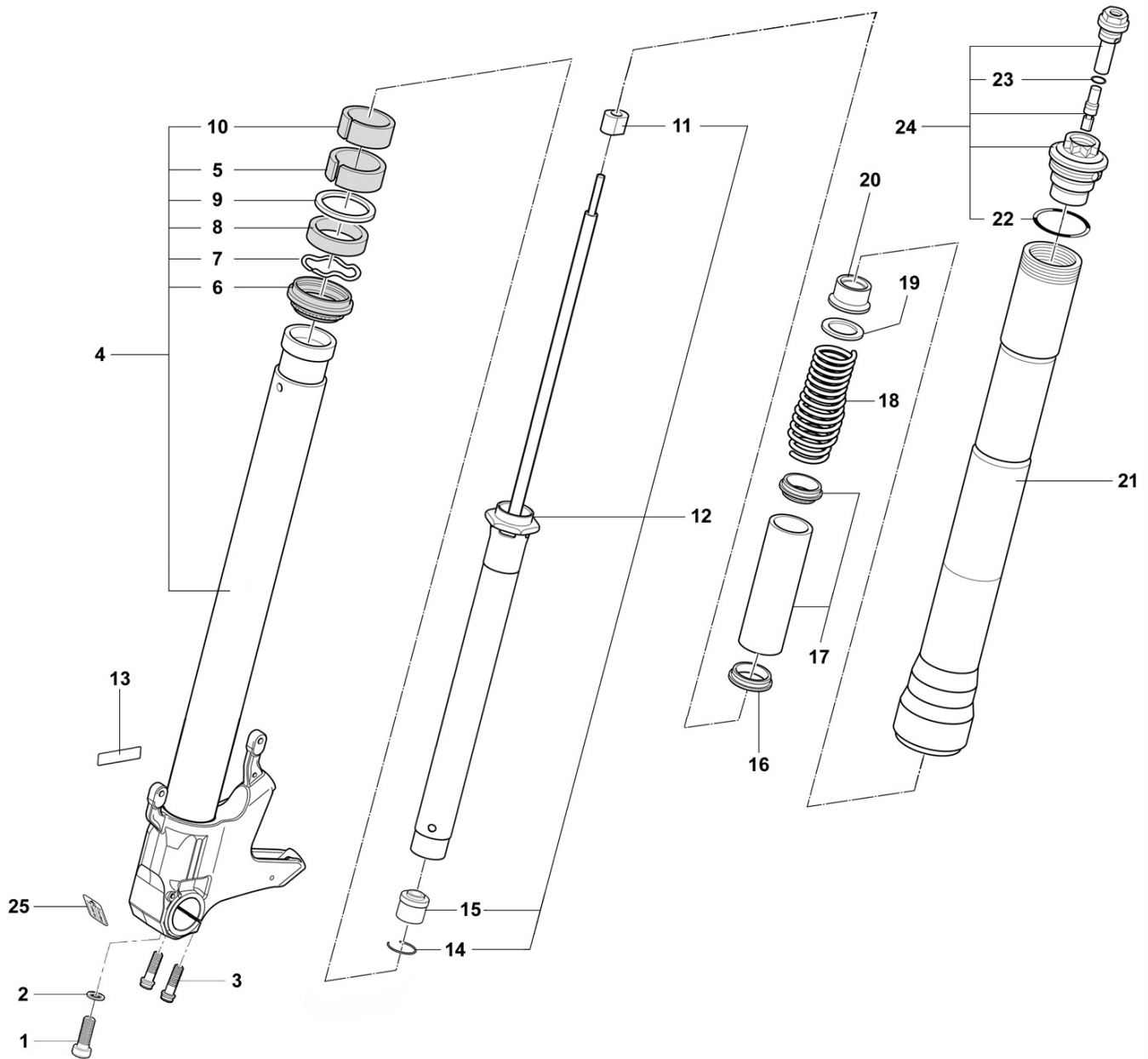

FORCELLA DESTRA (BRUTALE 1090 RR)RIGHT-HAND FORK (BRUTALE 1090 RR) • FOURCHE DROITE (BRUTALE 1090 RR)
RECHTE GABEL (BRUTALE 1090 RR) • HORQUILLA DERECHA (BRUTALE 1090 RR)

N.	Code	Q.ty	Note	Brutale 990 R	Brutale 1090 RR	Brutale	► I FRAME I ►	► I ENGINE I ►
1	800097784	1			•			
2	800046511	1			•			
3	8000B2689	2			•			
4	8B00B2160	1			•			
5	8000A1860	1			•			
6	8000A4690	1			•			
7	800089274	1			•			
8	800086500	1			•			
9	800089275	1			•			
10	800086503	1			•			
11	800081174	1			•			
12	8000B4263	1			•			
13	8000A8286	1			•			
14	800081164	1			•			
15	8000B4275	1			•			
16	8000A1863	1			•			
17	8000B2164	1			•			
18	8000B2137	1			•			
19	8000A1867	1			•			
20	8000A1868	1			•			
21	8000B4261	1			•			
22	8000A1870	1			•			
23	8000A0817	1			•			
24	8000B4265	1			•			
25	8000B4628	1			•			



FORCELLA SINISTRA (BRUTALE 1090 RR)

LEFT-HAND FORK (BRUTALE 1090 RR) • FOURCHE GAUCHE (BRUTALE 1090 RR)
LINKE GABEL (BRUTALE 1090 RR) • HORQUILLA IZQUIERDA (BRUTALE 1090 RR)

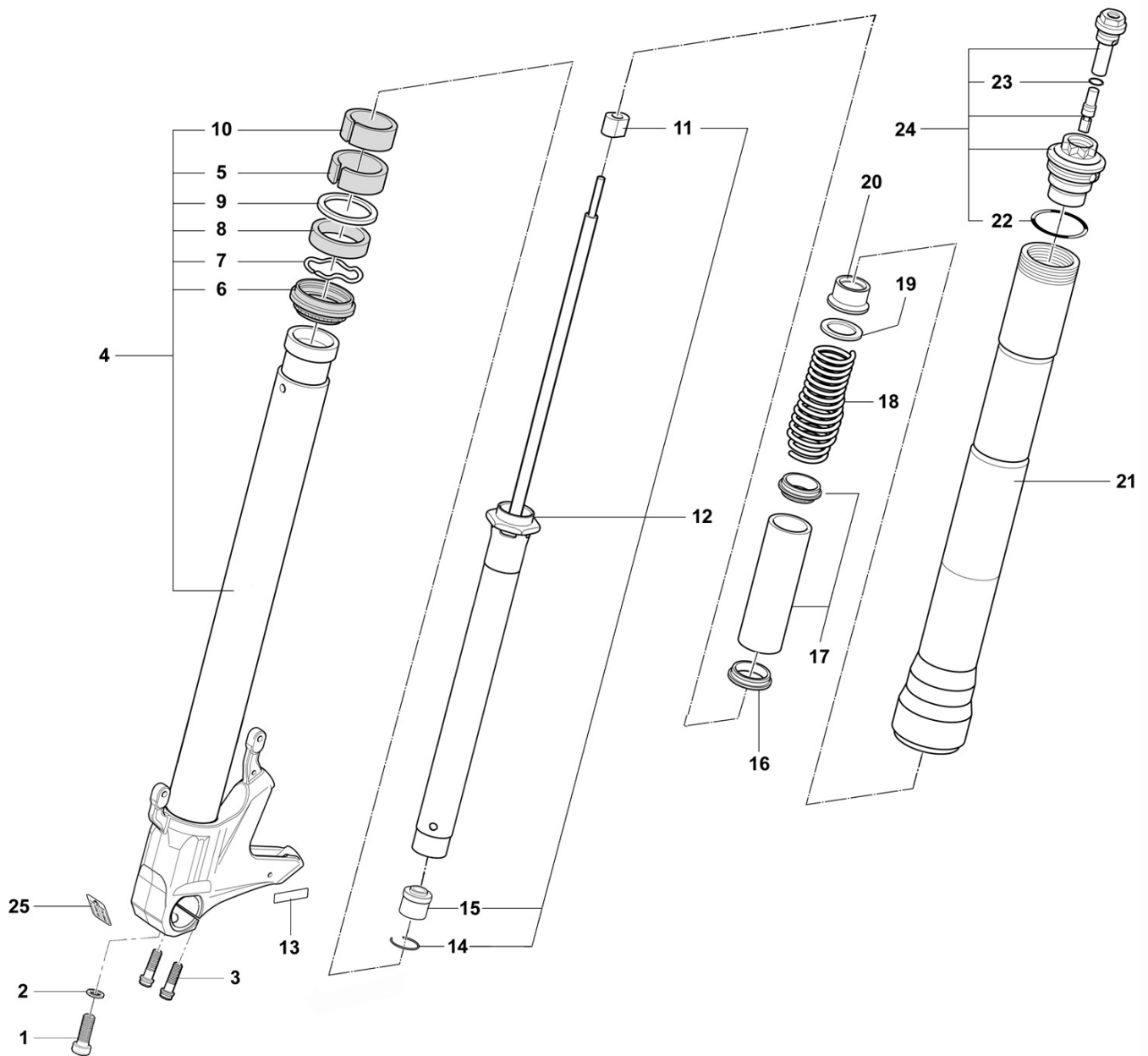

FORCELLA SINISTRA (BRUTALE 1090 RR)LEFT-HAND FORK (BRUTALE 1090 RR) • FOURCHE GAUCHE (BRUTALE 1090 RR)
LINKE GABEL (BRUTALE 1090 RR) • HORQUILLA IZQUIERDA (BRUTALE 1090 RR)

N.	Code	Q.ty	Note	Brutale 990 R	Brutale 1090 RR	Brutale	► I FRAME I ►	► I ENGINE I ►
1	800097784	1			•			
2	800046511	1			•			
3	8000B2689	2			•			
4	8B00B2159	1			•			
5	8000A1860	1			•			
6	8000A4690	1			•			
7	800089274	1			•			
8	800086500	1			•			
9	800089275	1			•			
10	800086503	1			•			
11	800081174	1			•			
12	8000B4264	1			•			
13	8000A8286	1			•			
14	800081164	1			•			
15	8000B4275	1			•			
16	8000A1863	1			•			
17	8000B2164	1			•			
18	8000B2137	1			•			
19	8000A1867	1			•			
20	8000A1868	1			•			
21	8000B4261	1			•			
22	8000A1870	1			•			
23	8000A0817	1			•			
24	8A00B4265	1			•			
25	8000B4628	1			•			



ASSIEME RUOTA POSTERIORE

REAR WHEEL ASSEMBLY • ENSEMBLE ROUE ARRIÈRE
BAUGRUPPE HINTERRAD • CONJUNTO RUEDA TRASERA

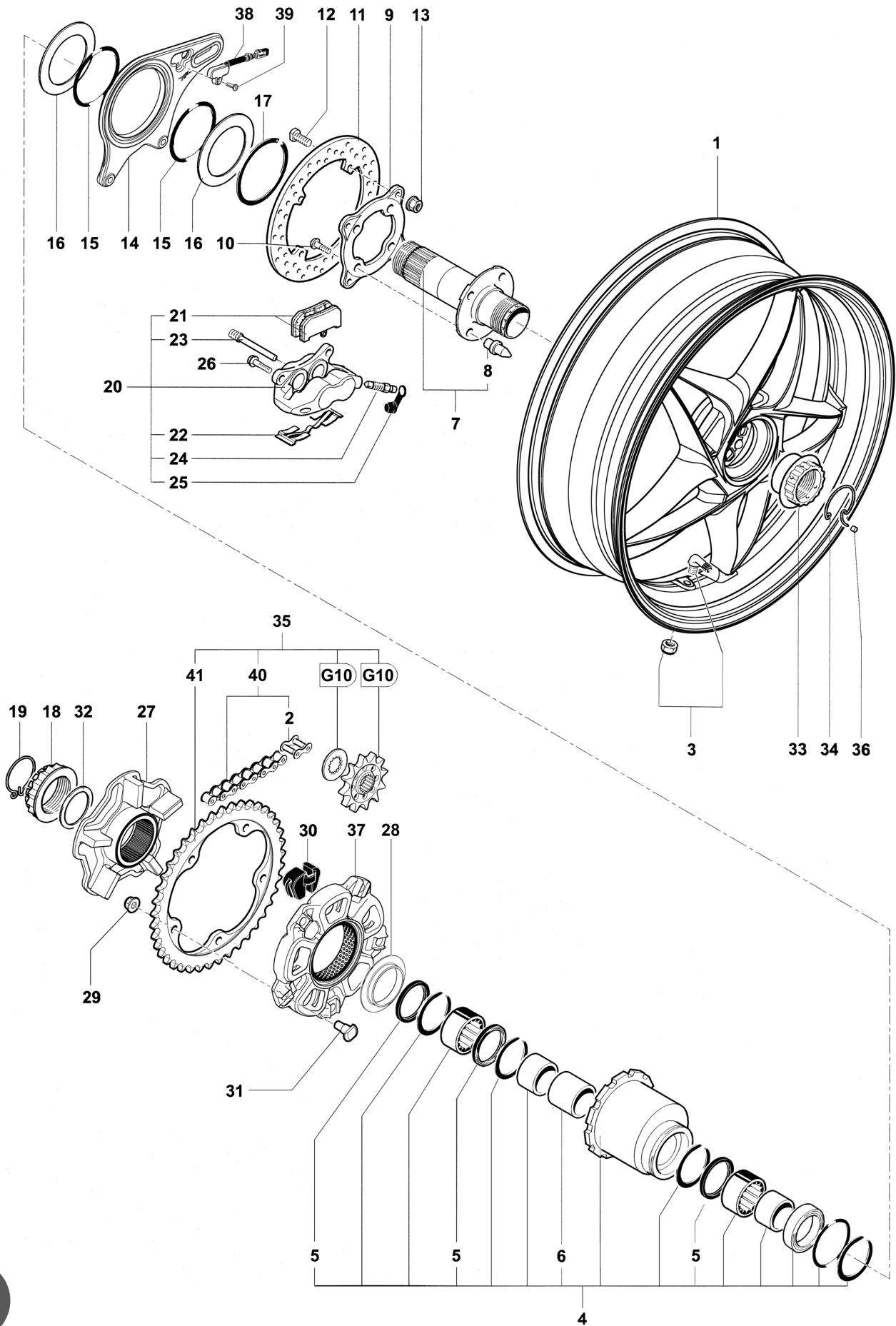

ASSIEME RUOTA POSTERIORE

 REAR WHEEL ASSEMBLY • ENSEMBLE ROUE ARRIÈRE
 BAUGRUPPE HINTERRAD • CONJUNTO RUEDA TRASERA



N.	Code	Q.ty	Note	Brutale 990 R	Brutale 1090 RR	Brutale	► I FRAME I ►	► I ENGINE I ►
1	80A0B3098	1		•				
1	80A0B3347	1			•			
1	80B0B3098	1				•		
2	8000B1438	1	①	•	•	•		
3	8000B3195	1		•	•	•		
4	8000B2143	1		•	•	•		
5	800084909	3		•	•	•		
6	8000B2149	1		•	•	•		
7	8000B3198	1		•	•	•		
8	80A084901	4		•	•	•		
9	800084890	1		•	•	•		
10	80A084902	4		•	•	•		
11	8A00B1654	1		•	•	•		
12	8000B2767	4		•	•	•		
13	800084891	4		•	•	•		
14	8A00B0976	1		•	•	•		
15	800086702	2		•	•	•		
16	800084893	2		•	•	•		
17	800084913	1		•	•	•		
18	800084904	1		•	•	•		
19	800084898	1		•	•	•		
20	80A082753	1		•	•	•		
21	800082748	1		•	•	•		
22	800082746	1		•	•	•		
23	800082743	1		•	•	•		
24	800089484	1		•	•	•		
25	800089491	1		•	•	•		
26	8A00B2690	2		•	•	•		
27	8000B2145	1		•	•	•		
28	8000B2150	1		•	•	•		
29	8000B2712	5		•	•	•		
30	8000B2151	5		•	•	•		
31	80A0A3248	5		•	•	•		
32	800084894	1		•	•	•		
33	800084903	1		•	•	•		
34	800084899	1		•	•	•		
35	8000B4033	1		•	•	•		
35	8000B5437	1				•		
36	800094030	1		•	•	•		
37	8000B3390	1		•	•	•		
38	8000B2967	1		•	•	•		
39	8B0090901	1		•	•	•		
40	8A00B1437	1		•	•	•		
41	80A0A3247	1	Z = 41	•	•			
41	8BA0A3247	1	Z = 40			•		

① Per catena di trasmissione Regina 525 ZRPK - For drive chain Regina 525 ZRPK - Pour chaîne de transmission Regina 525 ZRPK - Für Antriebskette Regina 525 ZRPK - Para cadena de transmisión Regina 525 ZRPK.

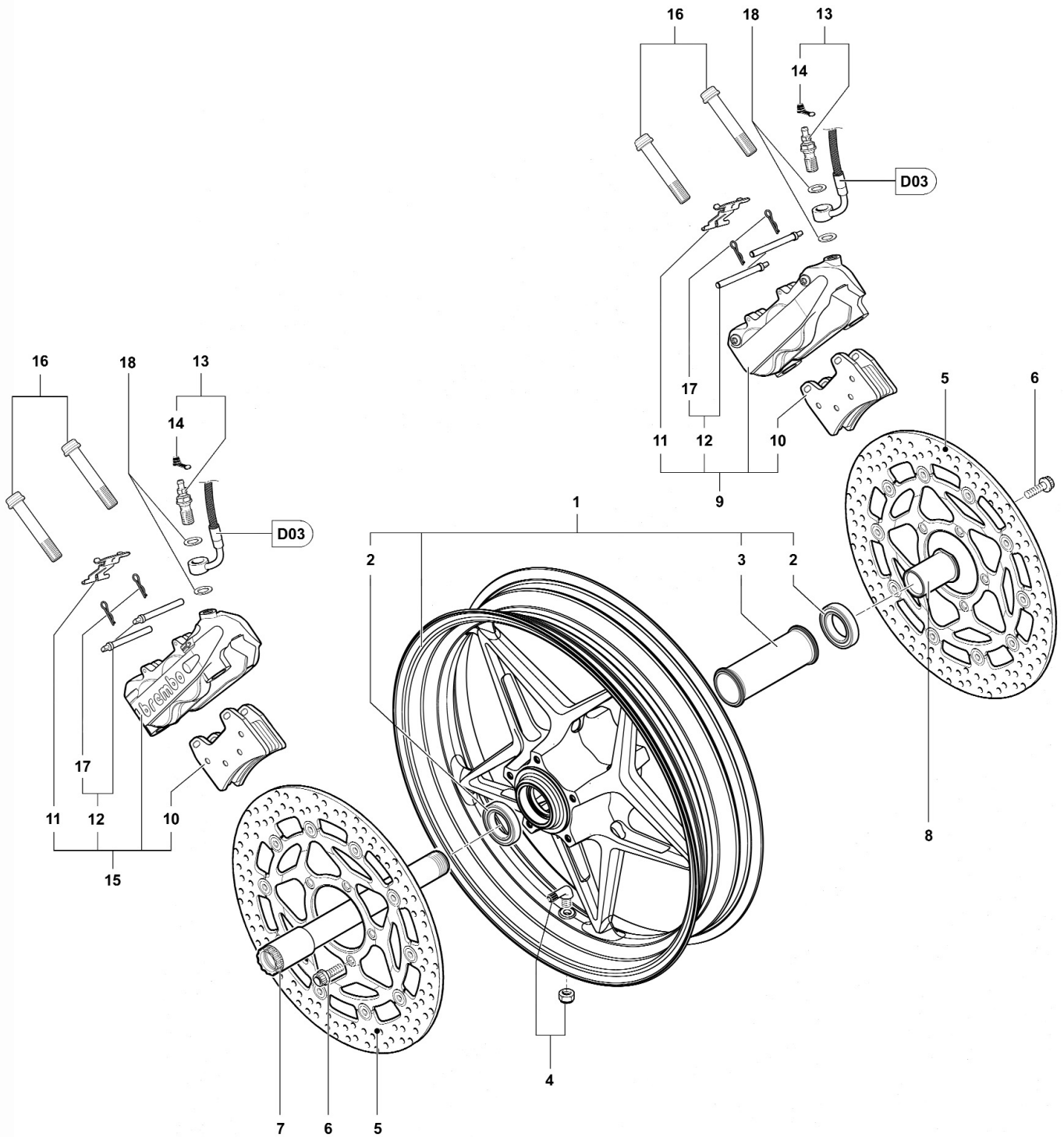

ASSIEME RUOTA ANTERIORE (B5 990 R / BRUTALE MY 2011)

FRONT WHEEL ASSEMBLY (B5 990 R / BRUTALE MY 2011) • ENSEMBLE ROUE AVANT (B5 990 R / BRUTALE MY 2011)
BAUGRUPPE VORDERRAD (B5 990 R / BRUTALE MY 2011) • CONJUNTO RUEDA DELANTERA (B5 990 R / BRUTALE MY 2011)



ASSIEME RUOTA ANTERIORE (B5 990 R / BRUTALE MY 2011)FRONT WHEEL ASSEMBLY (B5 990 R / BRUTALE MY 2011) • ENSEMBLE ROUE AVANT (B5 990 R / BRUTALE MY 2011)
BAUGRUPPE VORDERRAD (B5 990 R / BRUTALE MY 2011) • CONJUNTO RUEDA DELANTERA (B5 990 R / BRUTALE MY 2011)

N.	Code	Q.ty	Note	Brutale 990 R	Brutale 1090 RR	Brutale	► I FRAME I ►	► I ENGINE I ►
1	8000B3163	1		•				
1	80A0B3163	1				•		
2	8A0026846	2		•		•		
3	8000B3200	1		•		•		
4	8000B3195	1		•		•		
5	8AA082759	2		•		•		
6	8000B2690	10		•		•		
7	8A00A3468	1		•		•		
8	80A0A3469	1		•		•		
9	8000B1545	1		•		•		
10	8000B1593	2		•		•		
11	800088776	2		•		•		
12	800088773	2		•		•		
13	8000A3975	2		•		•		
14	800053259	2		•		•		
15	8000B1544	1		•		•		
16	8K00B2691	4		•		•		
17	800088777	2		•		•		
18	800021480	4		•		•		



ASSIEME RUOTA ANTERIORE (BRUTALE 1090 RR)

FRONT WHEEL ASSEMBLY (BRUTALE 1090 RR) • ENSEMBLE ROUE AVANT (BRUTALE 1090 RR)

BAUGRUPPE VORDERRAD (BRUTALE 1090 RR) • CONJUNTO RUEDA DELANTERA (BRUTALE 1090 RR)

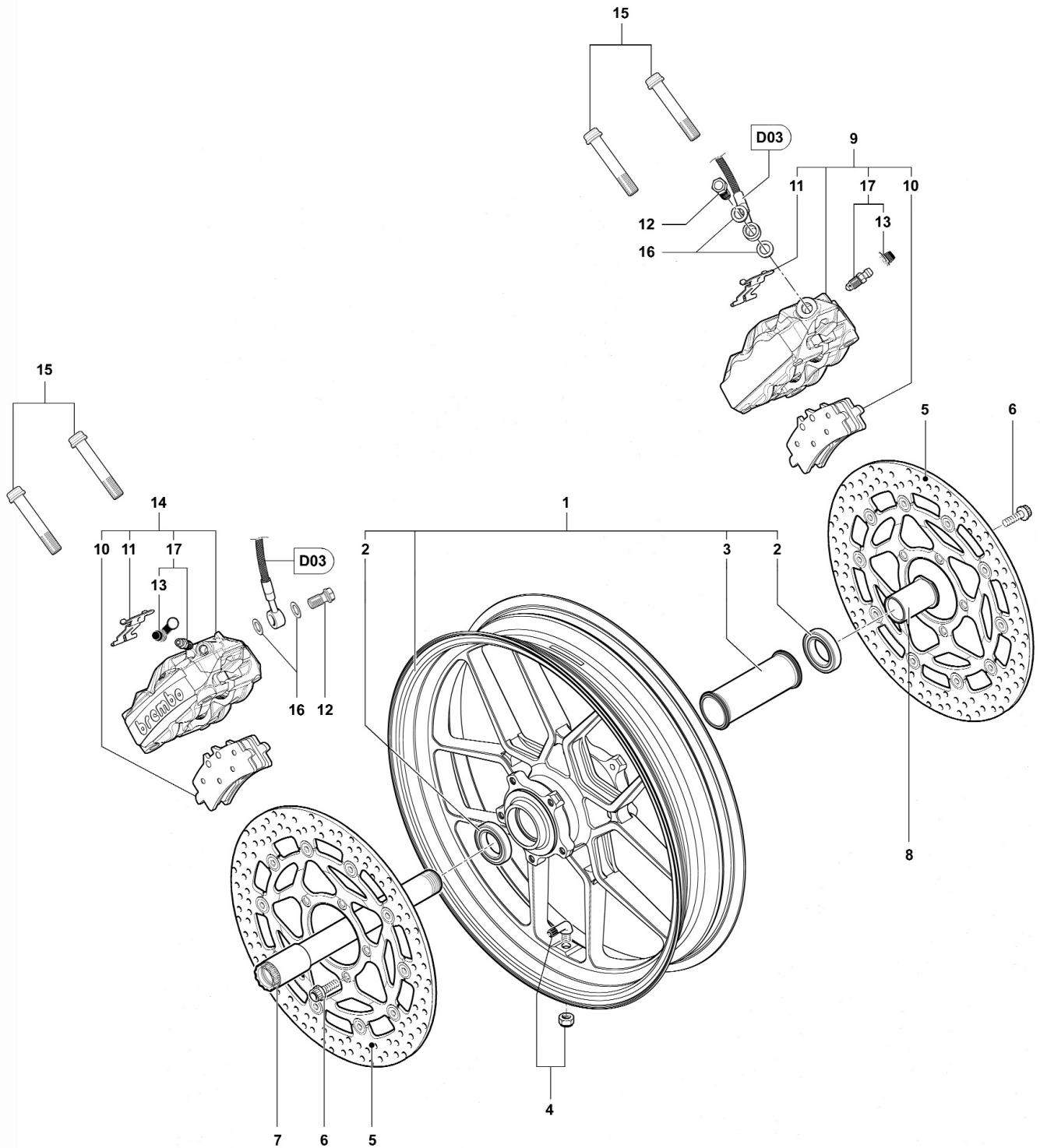

ASSIEME RUOTA ANTERIORE (BRUTALE 1090 RR)

FRONT WHEEL ASSEMBLY (BRUTALE 1090 RR) • ENSEMBLE ROUE AVANT (BRUTALE 1090 RR)

BAUGRUPPE VORDERRAD (BRUTALE 1090 RR) • CONJUNTO RUEDA DELANTERA (BRUTALE 1090 RR)



N.	Code	Q.ty	Note	Brutale 990 R	Brutale 1090 RR	Brutale	► I FRAME I ►	► I ENGINE I ►
1	8000B3352	1			•			
2	8A0026846	2			•			
3	8000B3672	1			•			
4	8000B3195	1			•			
5	8000B3353	2			•			
6	8A00B2690	10			•			
7	8A00A3468	1			•			
8	80A0A3469	1			•			
9	8000B1543	1			•			
10	8000B1601	2			•			
11	8000B1602	2			•			
12	8000B1948	2			•			
13	8000A2042	2			•			
14	8000B1542	1			•			
15	8K00B2691	4			•			
16	800021480	4			•			
17	8000A2041	2			•			



ASSIEME PEDANA SINISTRA

LEFT-HAND FOOTREST ASSEMBLY • ENSEMBLE REPOSE-PIEDS GAUCHE
BAUGRUPPE LINKES FUSSBRETT • CONJUNTO ESTRIBO IZQUIERDO

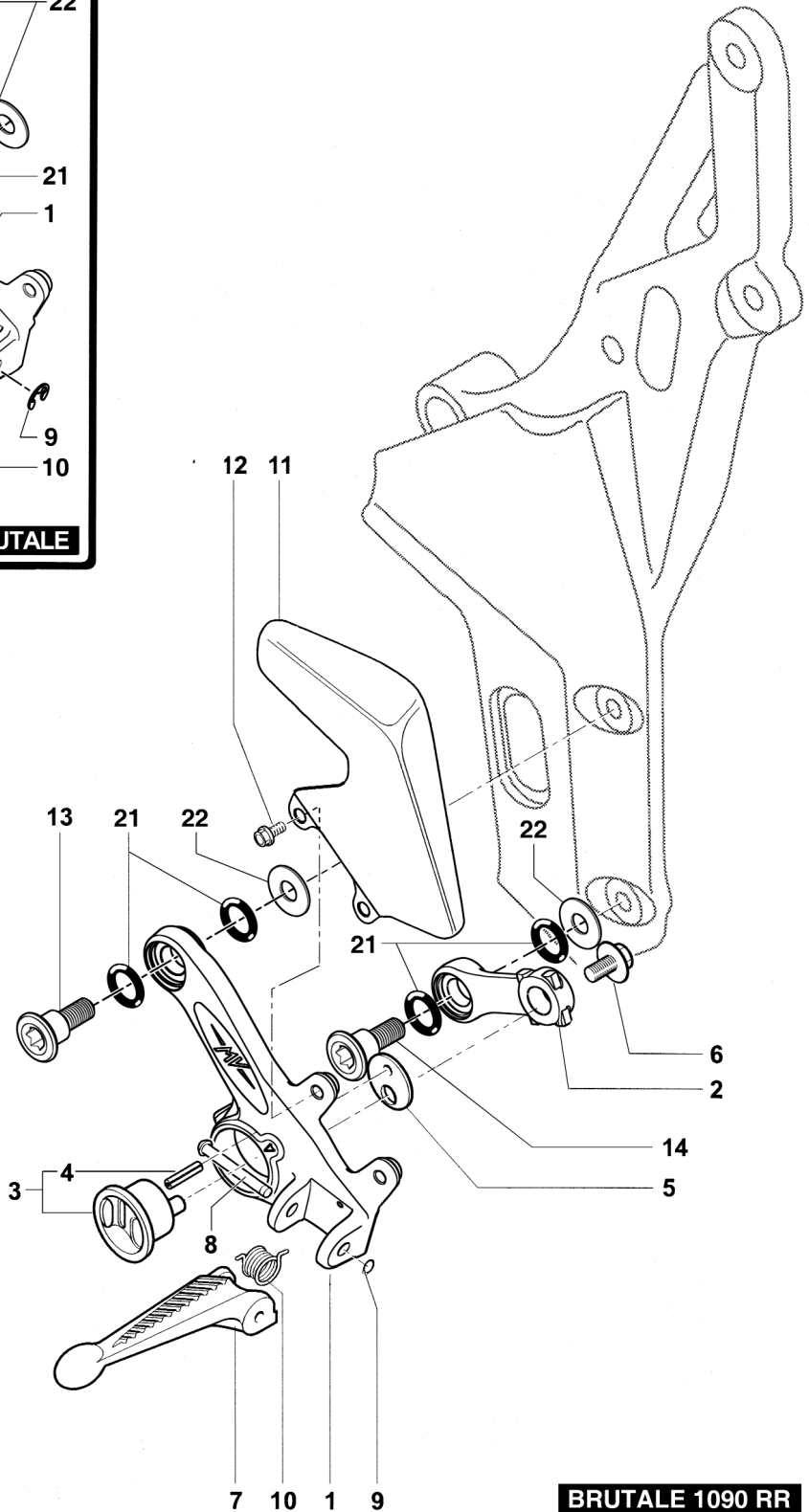
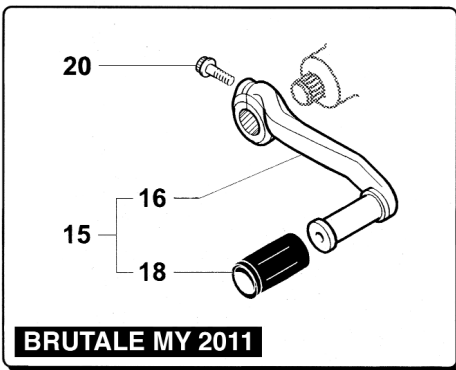
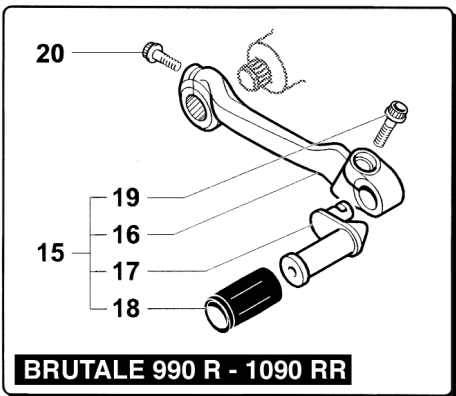
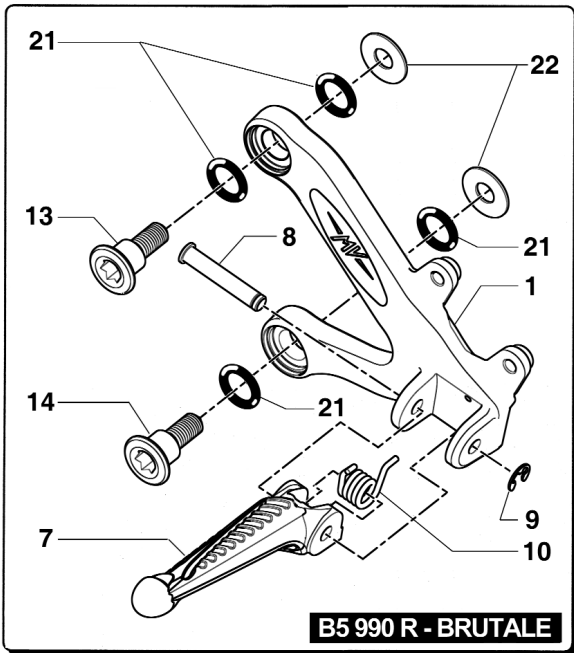

ASSIEME PEDANA SINISTRA

 LEFT-HAND FOOTREST ASSEMBLY • ENSEMBLE REPOSE-PIEDS GAUCHE
 BAUGRUPPE LINKES FUSSBRETT • CONJUNTO ESTRIBO IZQUIERDO

N.	Code	Q.ty	Note	Brutale 990 R	Brutale 1090 RR	Brutale	► I FRAME I ►	► I ENGINE I ►
1	8000B3499	1		•		•		
1	8000B3667	1			•			
2	8000B3669	1			•			
3	800092891	1			•			
4	800090314	1			•			
5	800089777	1			•			
6	8000B2749	1			•			
7	800087465	1		•	•	•		
8	80A090416	1		•	•	•		
9	800090429	1		•	•	•		
10	80A090418	1		•	•	•		
11	8000B4111	1		•	•	•		
12	8A00B2681	2		•	•	•		
13	8A00B3505	1		•	•	•		
14	8A00B3505	1		•	•	•		
15	8000B3103	1		•	•			
15	8000B4593	1				•		
16	800089759	1		•	•			
16	8000B4326	1				•		
17	800089760	1		•	•			
18	800089298	1		•	•	•		
19	8D00B2688	1		•	•			
20	8D00B2688	1		•	•	•		
21	800023114	4		•	•	•		
22	8000B2723	2		•	•	•		



ASSIEME PEDANA DESTRA

RIGHT-HAND FOOTREST ASSEMBLY • ENSEMBLE REPOSE-PIEDS DROIT
BAUGRUPPE RECHTES FUSSBRETT • CONJUNTO ESTRIBO DERECHO

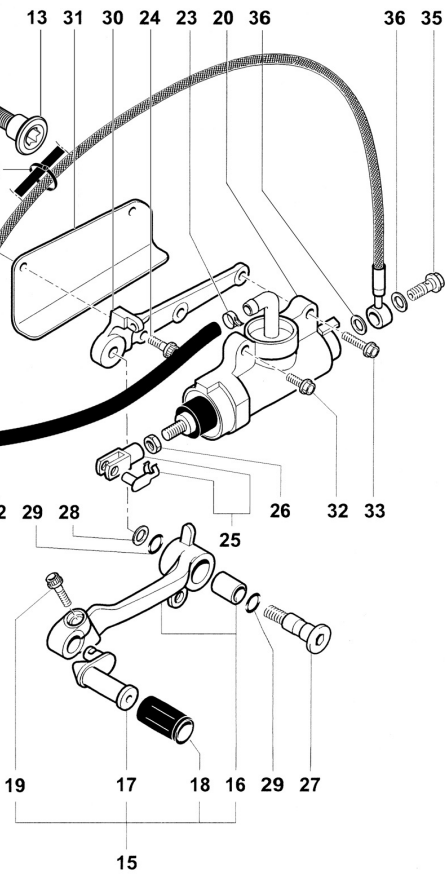
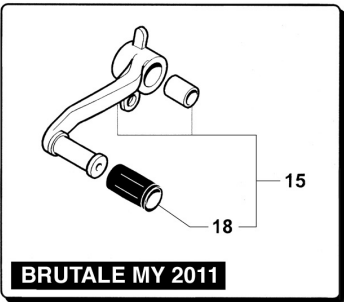
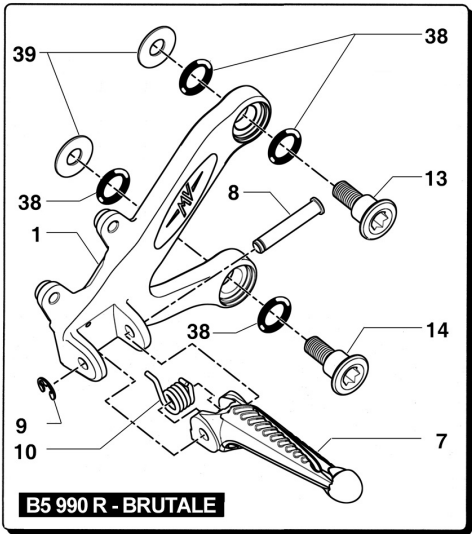
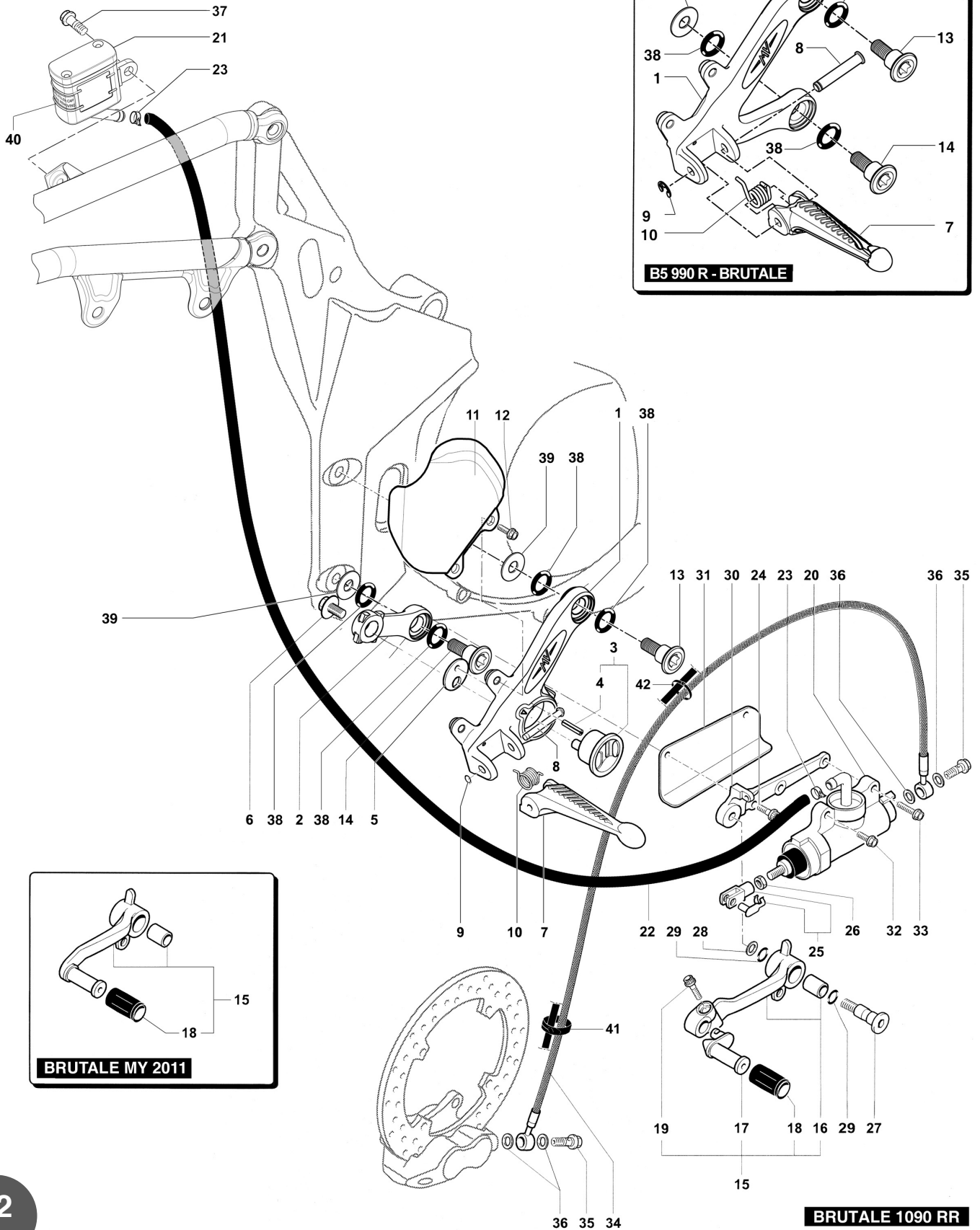

ASSIEME PEDANA DESTRA

 RIGHT-HAND FOOTREST ASSEMBLY • ENSEMBLE REPOSE-PIEDS DROIT
 BAUGRUPPE RECHTES FUSSBRETT • CONJUNTO ESTRIBO DERECHO



N.	Code	Q.ty	Note	Brutale 990 R	Brutale 1090 RR	Brutale	► I FRAME I ►	► I ENGINE I ►
1	8000B3500	1		•		•		
1	8000B3668	1			•			
2	8000B3669	1			•			
3	800092890	1			•			
4	800090314	1			•			
5	800089777	1			•			
6	8000B2749	1			•			
7	800087466	1		•	•	•		
8	80A090416	1		•	•	•		
9	800090429	1		•	•	•		
10	80A090418	1		•	•	•		
11	8000B4018	1		•	•	•		
12	8A00B2681	2		•	•	•		
13	8A00B3505	1		•	•	•		
14	8A00B3505	1		•	•	•		
15	8000B3101	1		•	•			
15	8000B4591	1				•		
16	800093314	1		•	•			
17	800089760	1		•	•			
18	800089298	1		•	•	•		
19	8D00B2688	1		•	•			
20	800089313	1		•	•	•		
21	800090315	1		•	•	•		
22	8J0070266	1		•	•	•		
23	800070700	2		•	•	•		
24	8B00B2690	1		•	•	•		
25	8000B2800	1		•	•	•		
26	61ND15062	1		•	•	•		
27	8A00B2802	1		•	•	•		
28	8000B2723	1		•	•	•		
29	800001199	2		•	•	•		
30	800089770	1		•	•	•		
31	800090312	1		•	•	•		
32	8E00B2681	1		•	•	•		
33	8J00B2681	1		•	•	•		
34	8000B3332	1		•	•	•		
35	80A091692	2		•	•	•		
36	800021480	4		•	•	•		
37	8B00B2681	1		•	•	•		
38	800023114	4		•	•	•		
39	8000B2723	2		•	•	•		
40	8000B3872	1		•	•	•		
41	800092668	1		•	•	•		
42	800056783	1		•	•	•		



ASSIEME MANUBRIO (LATO DESTRO)

HANDLEBAR ASSEMBLY (RIGHT SIDE) • ENSEMBLE GUIDON (CÔTÉ DROIT)

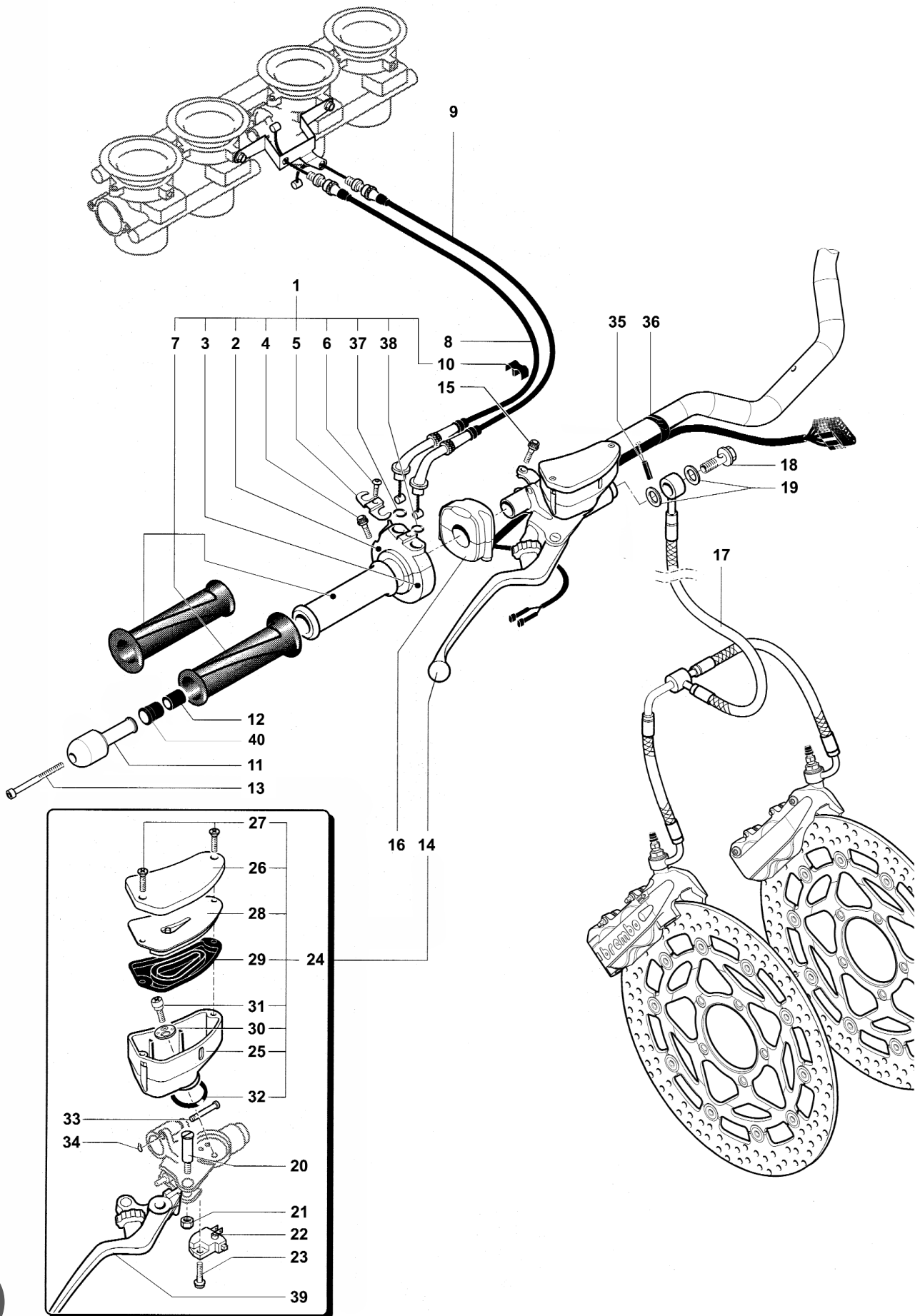
BAUGRUPPE LENKER (RECHTE SEITE) • CONJUNTO MANILLAR (LADO DERECHO)



ASSIEME MANUBRIO (LATO DESTRO)

 HANDLEBAR ASSEMBLY (RIGHT SIDE) • ENSEMBLE GUIDON (CÔTÉ DROIT)
 BAUGRUPPE LENKER (RECHTE SEITE) • CONJUNTO MANILLAR (LADO DERECHO)

N.	Code	Q.ty	Note	Brutale 990 R	Brutale 1090 RR	Brutale	► I FRAME I ►	► I ENGINE I ►
1	8000B2141	1		•	•	•		
2	80A092894	1		•	•	•		
3	80A090265	1		•	•	•		
4	8E00B2688	2		•	•	•		
5	800090266	1		•	•	•		
6	800093297	1		•	•	•		
7	8000B2140	1		•	•	•		
8	8000B4537	1		•	•			
8	8000B5169	1				•		
9	8000B4538	1		•	•			
9	8000B5170	1				•		
10	800092630	1		•	•	•		
11	8000A1402	1		•		•		
11	80B0A4425	1			•			
12	800090890	1		•	•	•		
13	60ND02520	1		•		•		
13	60ND02524	1			•			
14	8000B3452	1		•	•	•		
14	8000B4629	1	USA	•	•			
15	8F00B2688	1		•	•	•		
16	8000A6388	1		•	•			
16	8000B4568	1				•		
17	8000B3849	1		•		•		
17	8000B3850	1			•			
18	80A091692	1		•	•	•		
19	800021480	2		•	•	•		
20	800093299	1		•	•	•		
21	800093300	1		•	•	•		
22	800070864	1		•	•	•		
23	800070865	1		•	•	•		
24	80A098722	1		•	•	•		
25	800097121	1		•	•	•		
26	80A082728	1		•	•	•		
27	800093313	2		•	•	•		
28	800093302	1		•	•	•		
29	800093303	1		•	•	•		
30	800098962	1		•	•	•		
31	8000A1295	1		•	•	•		
32	800093306	1		•	•	•		
33	800082695	1		•	•	•		
34	800094643	1		•	•	•		
35	6AND55034	1		•	•	•		
36	800092248	1		•	•	•		
37	8000A2181	1		•	•	•		
38	8000A2180	1		•	•	•		
39	80A0A3823	1		•	•	•		
40	8000A4426	1			•			



ASSIEME MANUBRIO (LATO SINISTRO)

HANDLEBAR ASSEMBLY (LEFT SIDE) • ENSEMBLE GUIDON (CÔTÉ GAUCHE)
BAUGRUPPE LENKER (LINKE SEITE) • CONJUNTO MANILLAR (LADO IZQUIERDO)

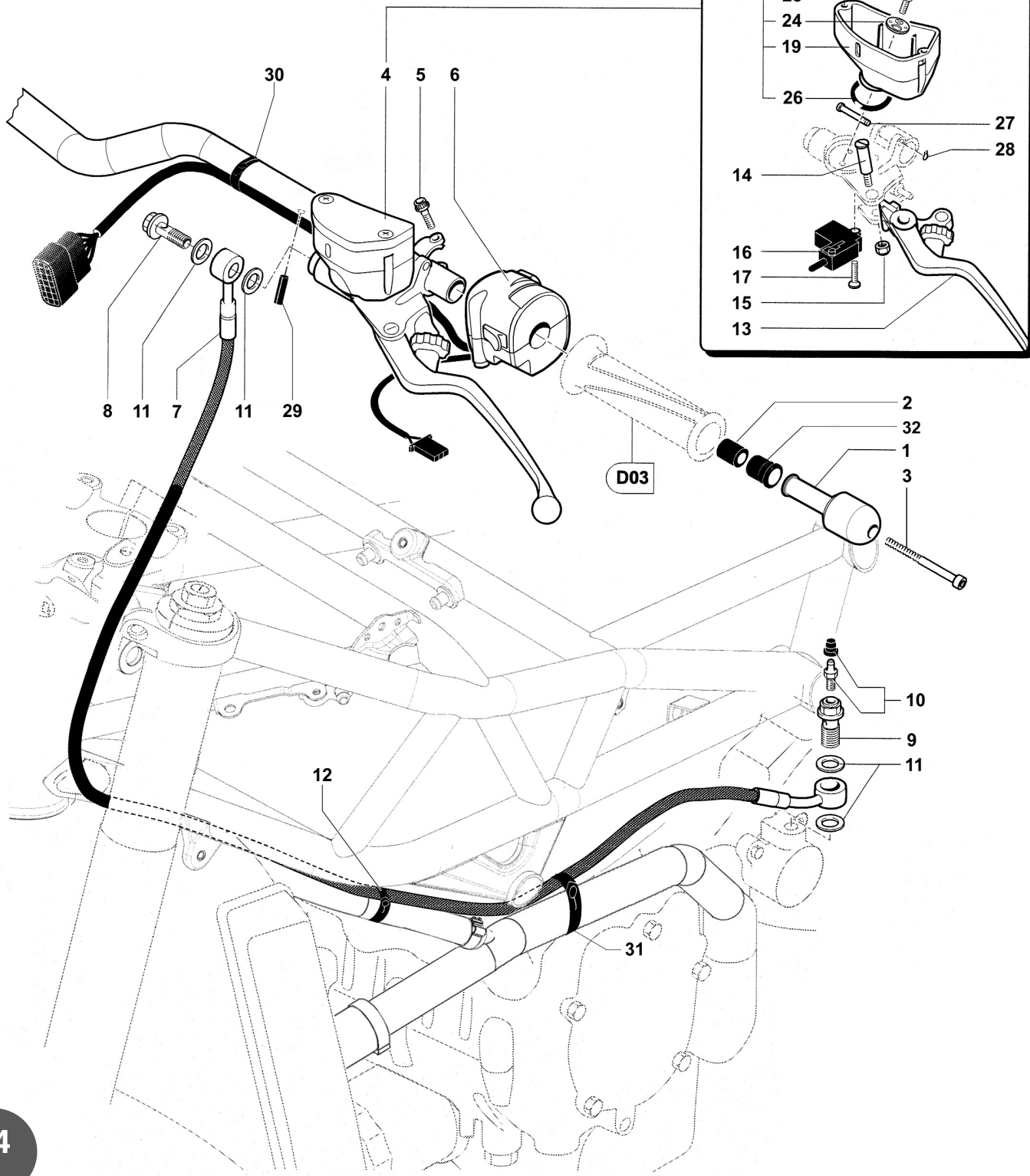

D04

2

ASSIEME MANUBRIO (LATO SINISTRO)

HANDLEBAR ASSEMBLY (LEFT SIDE) • ENSEMBLE GUIDON (CÔTÉ GAUCHE)

BAUGRUPPE LENKER (LINKE SEITE) • CONJUNTO MANILLAR (LADO IZQUIERDO)



N.	Code	Q.ty	Note	Brutale 990 R	Brutale 1090 RR	Brutale	► I FRAME I ►	► I ENGINE I ►
1	8000A1402	1		•		•		
1	80B0A4425	1			•			
2	800090890	1		•	•	•		
3	60ND02520	1		•		•		
3	60ND02524	1			•			
4	8000B3453	1		•	•	•		
4	8000B4630	1	USA	•	•			
5	8F00B2688	1		•	•	•		
6	8000A0922	1		•	•			
6	8A00B4567	1				•		
7	8000B1466	1		•	•	•		
8	80A091692	1		•	•	•		
9	80A091691	1		•	•	•		
10	80A033552	1		•	•	•		
11	800021480	4		•	•	•		
12	800092247	1		•	•	•		
13	80A093298	1		•	•	•		
14	800093299	1		•	•	•		
15	800093300	1		•	•	•		
16	800093307	1		•	•	•		
17	800093313	1		•	•	•		
18	80A098723	1		•	•	•		
19	800097122	1		•	•	•		
20	80A093310	1		•	•	•		
21	800093313	2		•	•	•		
22	800093311	1		•	•	•		
23	800093312	1		•	•	•		
24	800098962	1		•	•	•		
25	8000A1295	1		•	•	•		
26	800093306	1		•	•	•		
27	800082695	1		•	•	•		
28	800094643	1		•	•	•		
29	6AND55034	1		•	•	•		
30	800092248	1		•	•	•		
31	800092247	1		•	•	•		
32	8000A4426	1			•			



SERRATURE

LOCKS • VERROUILLAGES
SCHLÖSSER • CERRADURAS

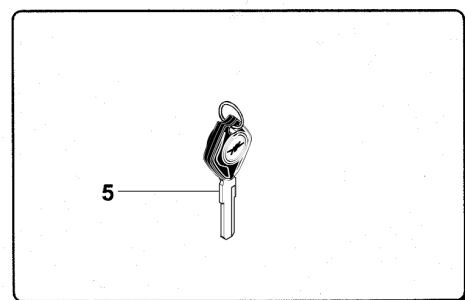
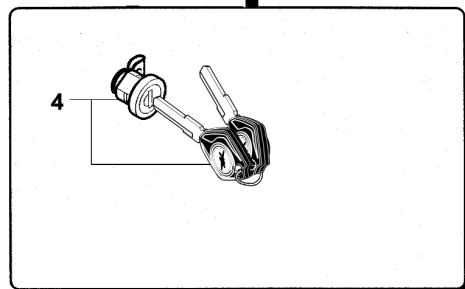
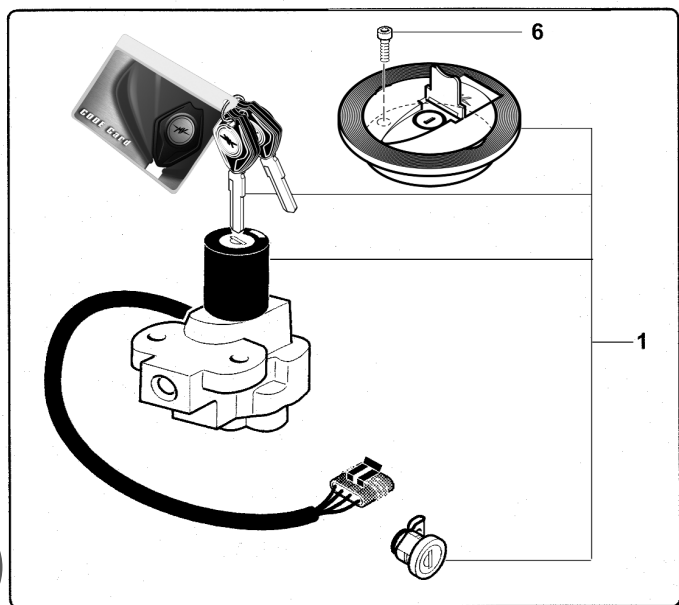
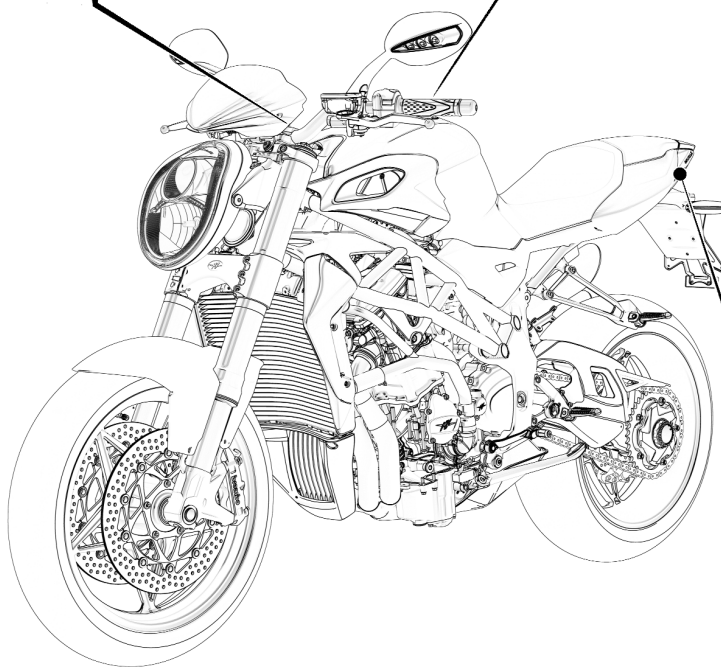
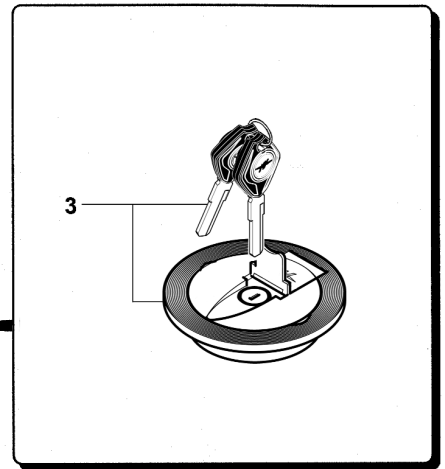
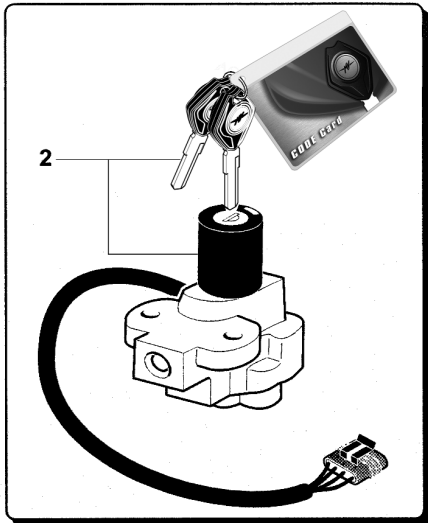

SERRATURELOCKS • VERROUILLAGES
SCHLÖSSER • CERRADURAS

N.	Code	Q.ty	Note	Brutale 990 R	Brutale 1090 RR	Brutale	► I FRAME I ►	► I ENGINE I ►
1	8000B5572	1		•	•	•		
2	8000B5574	1		•	•	•		
3	8000B4440	1		•	•	•		
4	8000B4441	1		•	•	•		
5	8000B5575	1		•	•	•		
6	8C00B2687	4		•	•	•		



ASSIEME CARENATURE

FAIRING ASSEMBLY • ENSEMBLE CARÉNAGE

BAUGRUPPE KAROSSERIE UND VERKLEIDUNG • CONJUNTO CARENADOS

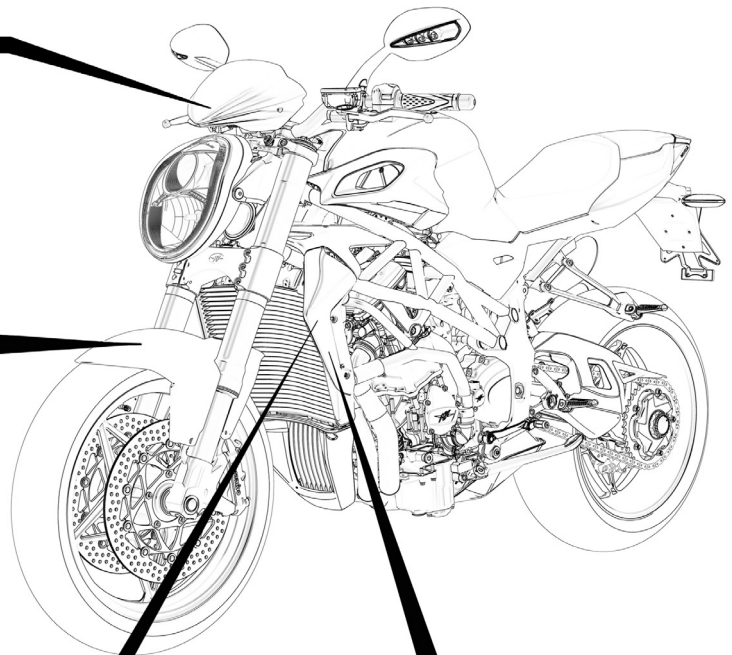
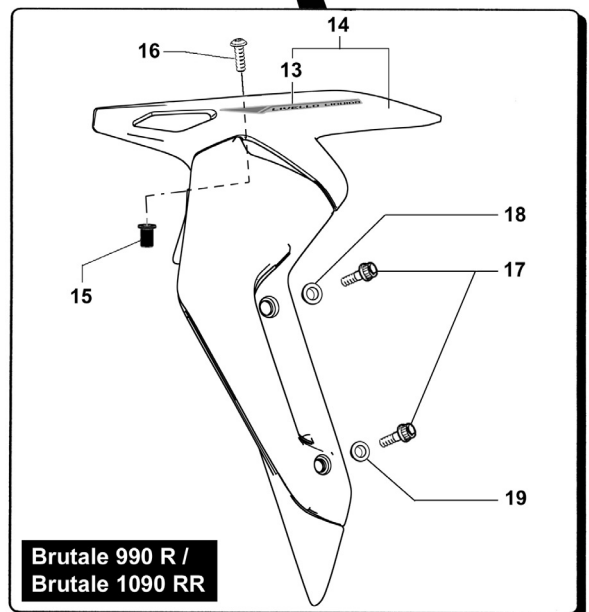
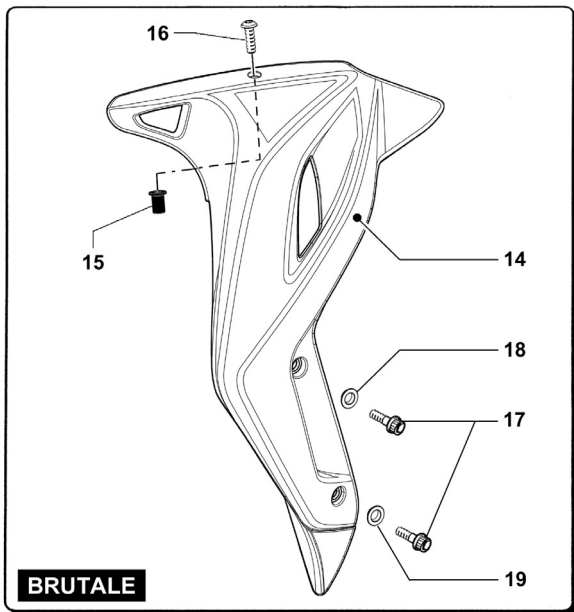
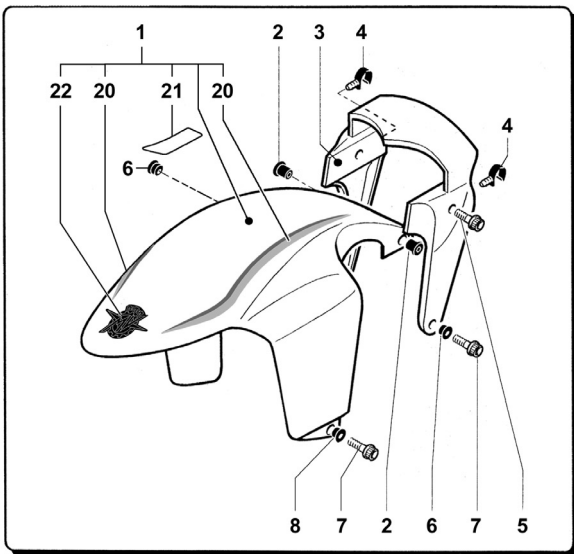
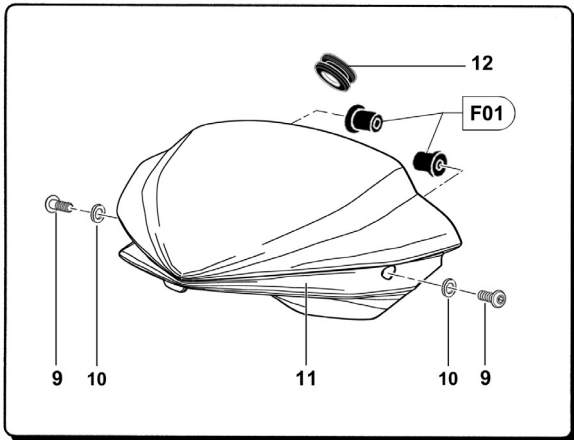

ASSIEME CARENATURE

FAIRING ASSEMBLY · ENSEMBLE CARÉNAGE

BAUGRUPPE KAROSSERIE UND VERKLEIDUNG · CONJUNTO CARENADOS



N.	Code	Q.ty	Note	Brutale 990 R	Brutale 1090 RR	Brutale	► I FRAME I ►	► I ENGINE I ►
1	8000B3972	1	A D	•				
1	80A0B3972	1	B E	•				
1	80B0B3972	1	C F	•				
1	8000B3520	1	A		•			
1	80A0B3520	1	B C E		•			
1	80B0B3520	1	D		•			
1	80C0B3520	1	F		•			
1	8000B5773	1				•		
2	800048245	2		•	•	•		
3	8A0098328	1		•	•	•		
4	800091005	2		•	•	•		
5	8H00B2688	2		•	•	•		
6	80A092670	2		•	•	•		
7	8A00B2688	4		•	•	•		
8	80A092670	2		•	•	•		
9	8A0090901	2		•	•	•		
10	800092882	2			•			
11	8000B3021	1		•		•		
11	80A0B3021	1			•			
12	800089293	1		•	•	•		
13	8000B3209	1		•	•			
14	8000B3053	1	A B C	•				
14	80B0B3053	1	D E F	•				
14	80A0B3053	1			•			
14	8000B4945	1				•		
15	800091022	1		•	•	•		
16	8A0090901	1		•	•	•		
17	8A00B2672	2		•	•	•		
18	8000B3097	1		•	•	•		
19	8A00B3097	1		•	•	•		
20	8000B4031	1	A		•			
20	80A0B4031	1	B C E		•			
20	80B0B4031	1	D		•			
20	80C0B4031	1	F		•			
21	8000A5239	1		•	•			
21	8000B5774	1				•		
22	80E090316	1	A D		•			
22	80B090316	1	B C E		•			
22	80G090316	1	F		•			

B5 990 R: **A D** Versione Rossa - Red version - Version Rouge - Rote Version - Versión Roja.
B E Versione Nero - Black version - Version Noire - Schwarze Version - Versión Negra.
C F Versione Bianco - White version - Version Blanche - Weiße Version - Versión Blanca.

B5 1090 RR: **A D** Versione Rosso/Argento - Red/Silver version - Version Rouge/Argent - Rot/Silber Version - Versión Rojo/Plata.
B E Versione Bianco/Nero - White/Black version - Version Blanche/Noire - Weiße/Schwarze Version - Versión Blanca/Negra.
C Versione Nero/Antracite - Black/Anthracite version - Version Noire/Anthracite - Schwarze/Anthrazit Version - Versión Negra/Antracita.
F Versione Argento/Grigio Titanium - Silver/Titanium Grey version - Version Argent/Gris Titanium - Silber/Grau Titanium Version - Versión Plata/Gris Titanium.



ASSIEME CARENATURE

FAIRING ASSEMBLY • ENSEMBLE CARÉNAGE

BAUGRUPPE KAROSSERIE UND VERKLEIDUNG • CONJUNTO CARENADOS

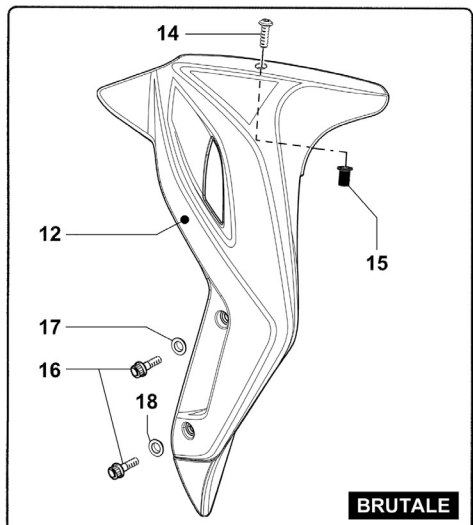
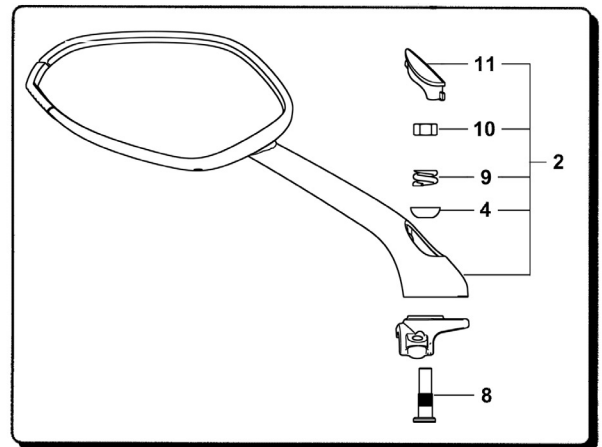
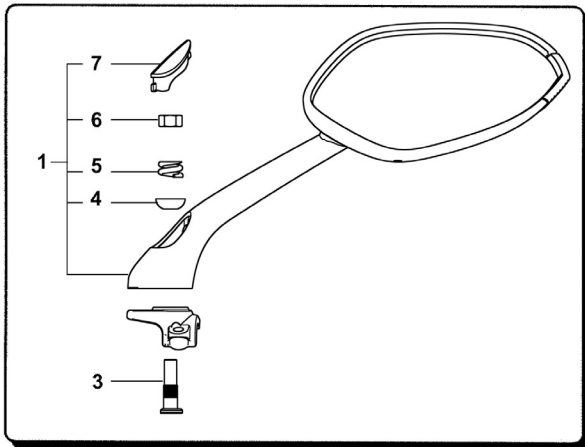

BRUTALE

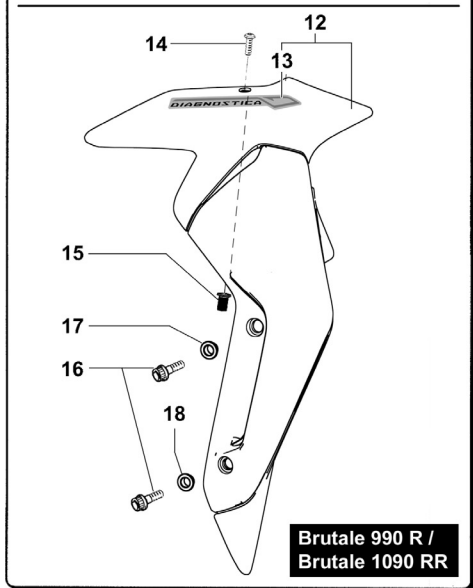

**Brutale 990 R /
Brutale 1090 RR**

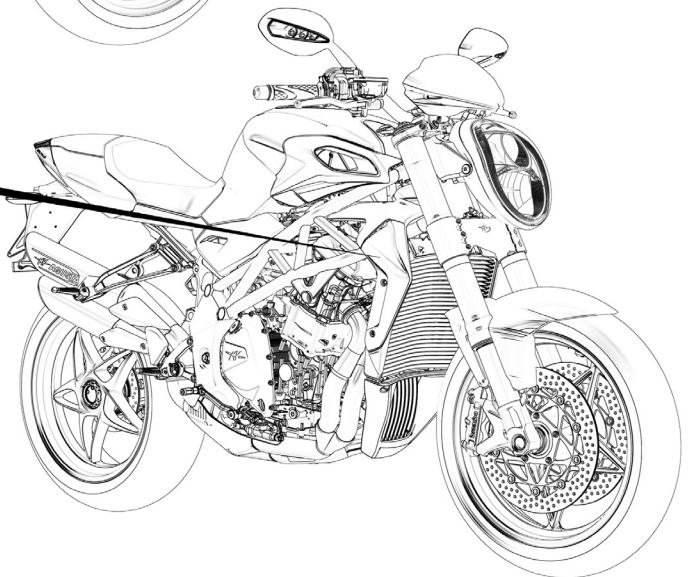
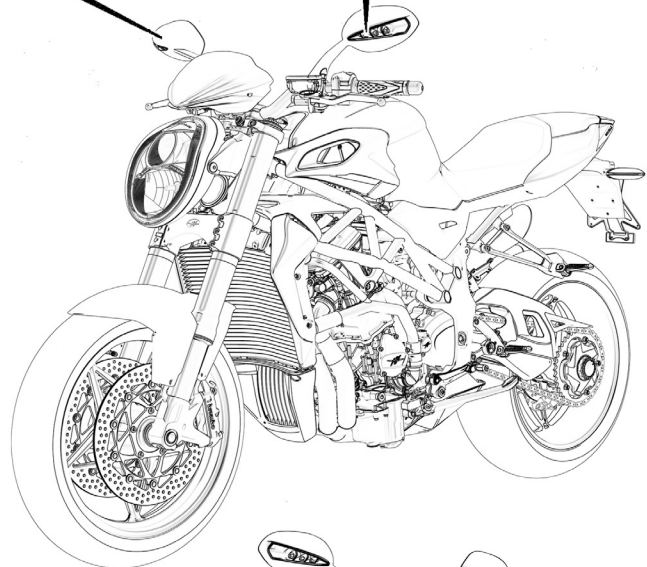

ASSIEME CARENATURE

FAIRING ASSEMBLY · ENSEMBLE CARÉNAGE

BAUGRUPPE KAROSSERIE UND VERKLEIDUNG · CONJUNTO CARENADOS



N.	Code	Q.ty	Note	Brutale 990 R	Brutale 1090 RR	Brutale	► I FRAME I ►	► I ENGINE I ►
1	8000B4080	1	①	•	•			
1	8000B4738	1				•		
2	8000B4079	1	①	•	•			
2	8000B4739	1				•		
3	8000B4086	1	①	•	•			
3	8000B4086	1				•		
4	8000B4085	2	①	•	•			
4	8000B4085	2				•		
5	8000B4084	1	①	•	•			
5	8000B4084	1				•		
6	80A090432	1	①	•	•			
6	80A090432	1				•		
7	8000B4083	1	①	•	•			
7	8000B4083	1				•		
8	8000B4086	1	①	•	•			
8	8000B4086	1				•		
9	8000B4084	1	①	•	•			
9	8000B4084	1				•		
10	80A090432	1	①	•	•			
10	80A090432	1				•		
11	8000B4083	1	①	•	•			
11	8000B4083	1				•		
12	8000B3054	1	A B C	•				
12	80B0B3054	1	D E F	•				
12	80A0B3054	1			•			
12	8000B4946	1				•		
13	8000B3208	1		•	•			
14	8A0090901	1		•	•	•		
15	800091022	1		•	•	•		
16	8A00B2672	2		•	•	•		
17	8000B3097	1		•	•	•		
18	8A00B3097	1		•	•	•		

① Esclusi gli USA (vedi tavola K01) - USA excluded (see table K01) - Sauf les USA (voir planche K01) - Ausschließlich USA (siehe Tafel K01)
 - Excluidos los USA (ver tabla K01).

B5 990 R: A D Versione Rossa - Red version - Version Rouge - Rote Version - Versión Roja.
 B E Versione Nero - Black version - Version Noire - Schwarze Version - Versión Negra.
 C F Versione Bianco - White version - Version Blanche - Weiße Version - Versión Blanca.

E02

3



ASSIEME AIRBOX
AIRBOX ASSEMBLY • ENSEMBLE AIRBOX
BAUGRUPPE AIRBOX • CONJUNTO AIRBOX

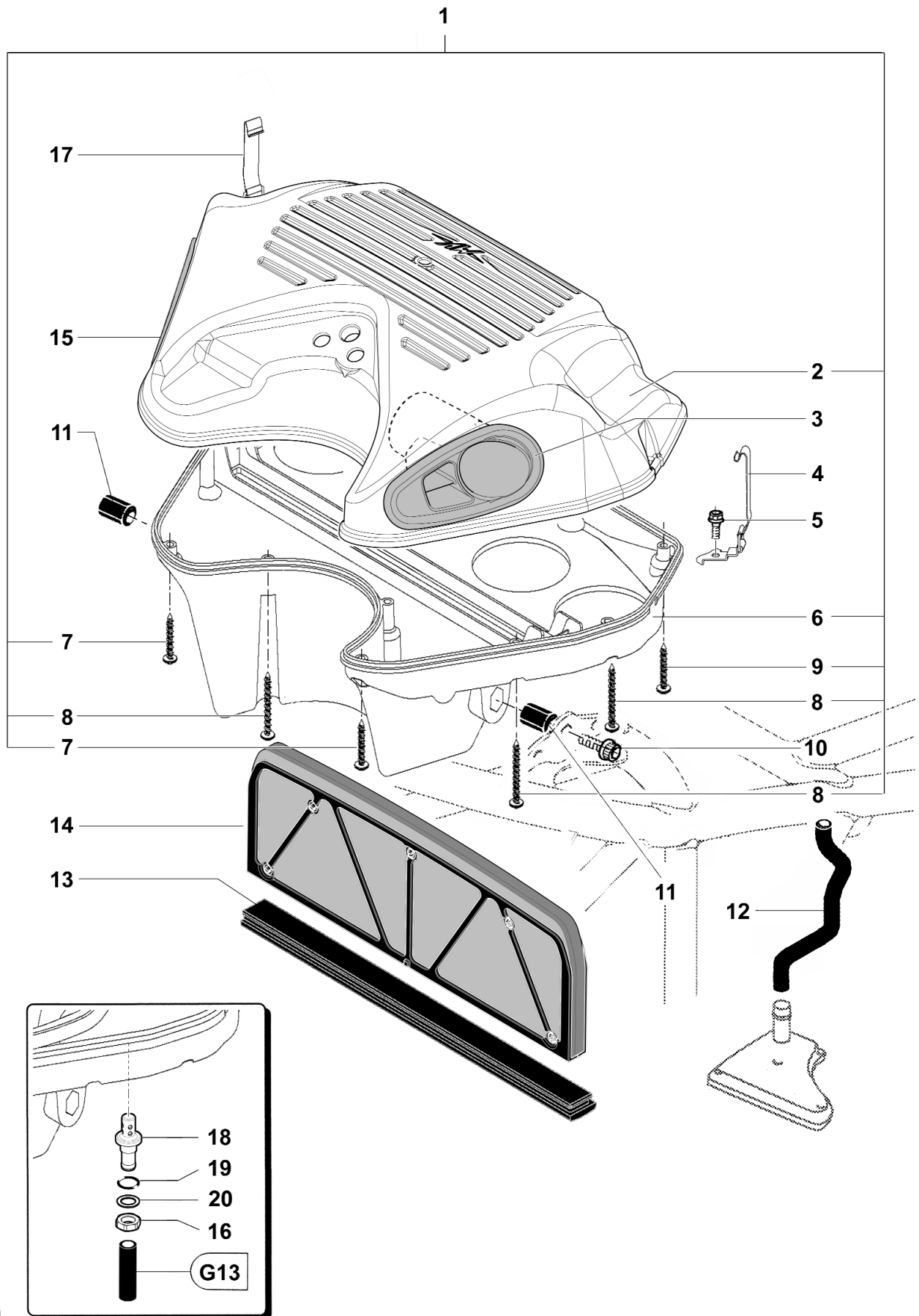

ASSIEME AIRBOXAIRBOX ASSEMBLY • ENSEMBLE AIRBOX
BAUGRUPPE AIRBOX • CONJUNTO AIRBOX

N.	Code	Q.ty	Note	Brutale 990 R	Brutale 1090 RR	Brutale	► I FRAME I ►	► I ENGINE I ►
1	8000B4191	1		•	•	•		
2	8000B4190	1		•	•	•		
3	8000B4193	1		•	•	•		
4	800099337	1		•	•	•		
5	8000B2687	2		•	•	•		
6	8B0097906	1		•	•	•		
7	8BA084658	3		•	•	•		
8	8DA084658	8		•	•	•		
9	8AA084658	2		•	•	•		
10	8000B2688	2		•	•	•		
11	800091008	2		•	•	•		
12	800098873	1		•	•	•		
13	800097910	1		•	•	•		
14	8000A9050	1		•	•	•		
15	8000B4192	1		•	•	•		
16	8000A3822	1		•	•	•		
17	800099336	1		•	•	•		
18	8000A3709	1		•	•	•		
19	8A0023114	1		•	•	•		
20	8000A3827	1		•	•	•		



ASSIEME SERBATOIO BENZINA
FUEL TANK ASSEMBLY • ENSEMBLE RÉSERVOIR DE CARBURANT
BAUGRUPPE TANK • CONJUNTO DEPÓSITO GASOLINA

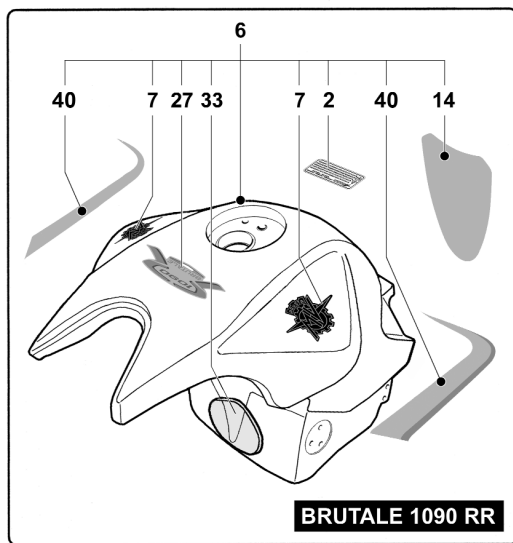
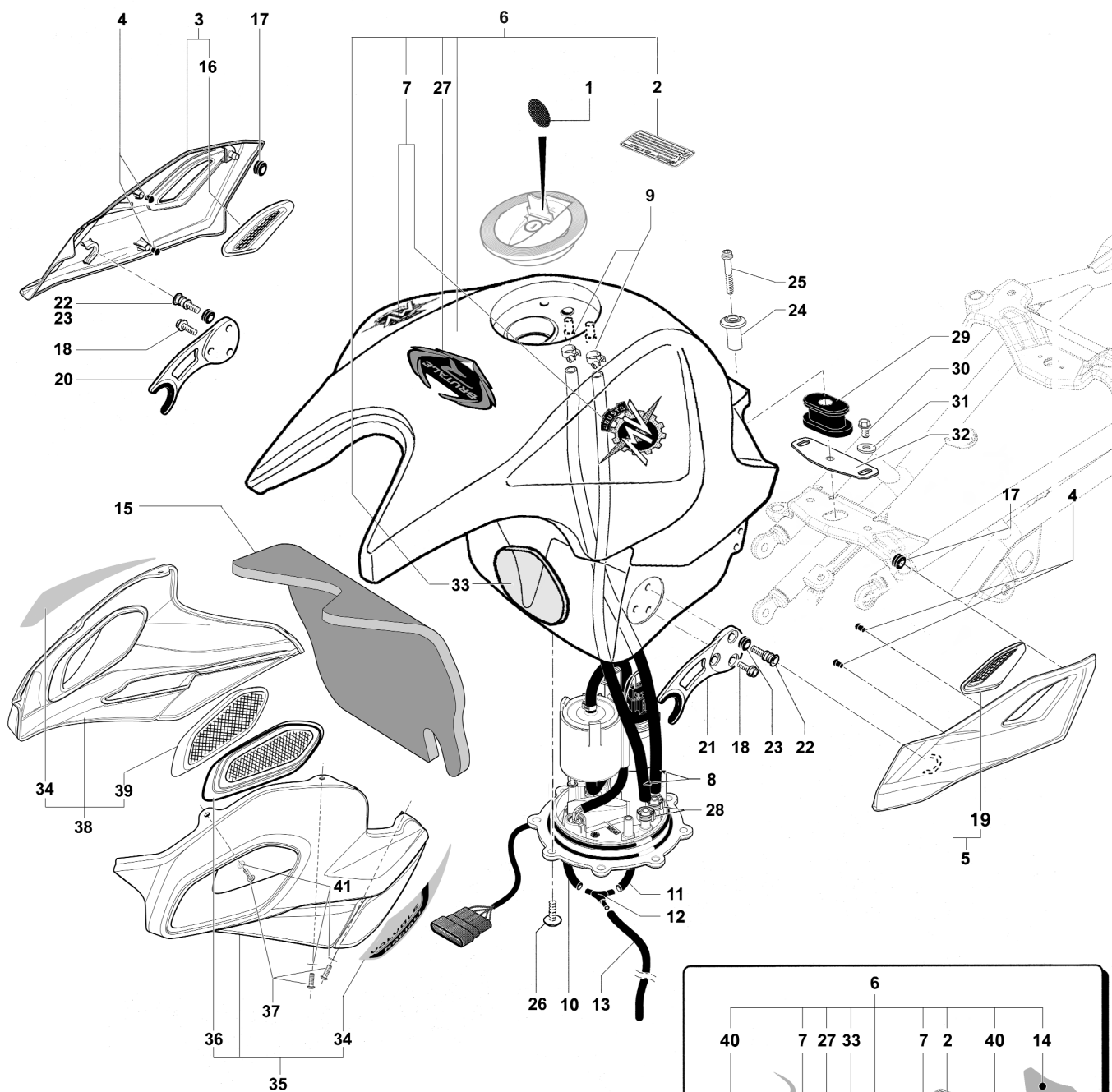

BRUTALE 1090 RR

ASSIEME SERBATOIO BENZINA

 FUEL TANK ASSEMBLY • ENSEMBLE RÉSERVOIR DE CARBURANT
 BAUGRUPPE TANK • CONJUNTO DEPÓSITO GASOLINA

N.	Code	Q.ty	Note	Brutale 990 R	Brutale 1090 RR	Brutale	► I FRAME I ►	► I ENGINE I ►
1	800092664	1		•	•	•		
2	8000A9698	1		•	•	•		
3	8000B2952	1	A B C	•				
3	80E0B2952	1	D E F	•				
3	80A0B2952	1	A D F		•			
3	80B0B2952	1	B E		•			
3	80C0B2952	1	C		•			
3	80D0B2954	1	A			•		
3	80D0B2952	1	B			•		
4	800090978	4		•	•	•		
5	8000B2951	1	A B C	•				
5	80E0B2951	1	D E F	•				
5	80A0B2951	1	A D F		•			
5	80B0B2951	1	B E		•			
5	80C0B2951	1	C		•			
5	80D0B2953	1	A			•		
5	80D0B2951	1	B			•		
6	8000B3139	1	A D	•				
6	8000B3140	1	USA A D	•				
6	80A0B3139	1	B E	•				
6	80A0B3140	1	USA B E	•				
6	80B0B3139	1	C F	•				
6	80B0B3140	1	USA C F	•				
6	8000B3384	1	A		•			
6	8000B3383	1	USA A		•			
6	80A0B3384	1	B E		•			
6	80A0B3383	1	USA B E		•			
6	80B0B3384	1	C		•			
6	80B0B3383	1	USA C		•			
6	80C0B3384	1	D		•			
6	80C0B3383	1	USA D		•			
6	80D0B3384	1	F		•			
6	80D0B3383	1	USA F		•			
6	8000B4600	1	A			•		
6	8000B4601	1	USA A			•		
6	80A0B4600	1	B			•		
6	80A0B4601	1	USA B			•		
7	800098832	2	A D	•				
7	80D098832	2	B E	•				
7	80B098832	2	C F	•				
7	80E098832	2	A D		•			
7	80A098832	2	B C E		•			
7	80H098832	2	F		•			
7	80F098832	2	A			•		
7	80J098832	2	B			•		
8	8C0090940	2		•	•			
9	8C0091687	2		•	•			



B5 990 R: **A D** Versione Rossa - Red version - Version Rouge - Rote Version - Versión Roja.
B E Versione Nero - Black version - Version Noire - Schwarze Version - Versión Negra.
C F Versione Bianco - White version - Version Blanche - Weiße Version - Versión Blanca.

B5 1090 RR: **A D** Versione Rosso/Argento - Red/Silver version - Version Rouge/Argent - Rot/Silber Version - Versión Rojo/Plata.
B E Versione Bianco/Nero - White/Black version - Version Blanche/Noire - Weiße/Schwarze Version - Versión Blanca/Negra.
C Versione Nero/Antracite - Black/Anthracite version - Version Noire/Anthracite - Schwarze/Anthrazit Version - Versión Negra/Antracita.
F Versione Argento/Grigio Titanium - Silver/Titanium Grey version - Version Argent/Gris Titanium - Silber/Grau Titanium Version - Versión Plata/Gris Titanium.

BRUTALE: **A** Versione Nero Opaco - Matt Black version - Version Noire Mat - Matte Schwarze Version - Versión Negra Mate.
B Versione Bianco Opaco - Matt White version - Version Blanche Mat - Matte Weiße Version - Versión Blanca Mate.



ASSIEME SERBATOIO BENZINA

FUEL TANK ASSEMBLY • ENSEMBLE RÉSERVOIR DE CARBURANT
BAUGRUPPE TANK • CONJUNTO DEPÓSITO GASOLINA

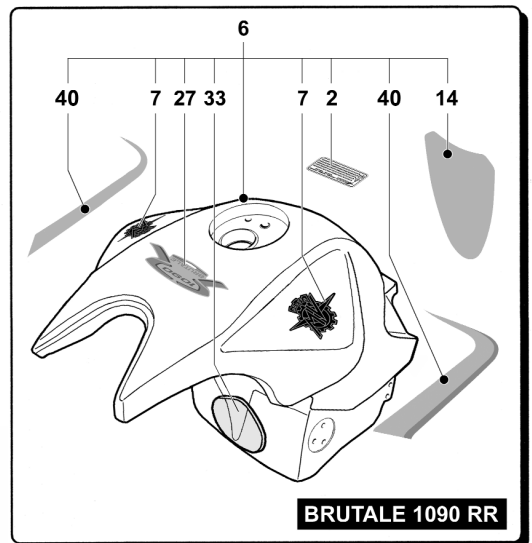

BRUTALE 1090 RR

ASSIEME SERBATOIO BENZINA

 FUEL TANK ASSEMBLY • ENSEMBLE RÉSERVOIR DE CARBURANT
 BAUGRUPPE TANK • CONJUNTO DEPÓSITO GASOLINA

N.	Code	Q.ty	Note	Brutale 990 R	Brutale 1090 RR	Brutale	► I FRAME I ►	► I ENGINE I ►
10	800091695	1	1	.	.	.		
11	800091690	1	1	.	.	.		
12	800091689	1	1	.	.	.		
13	800091688	1		.	.	.		
14	8000B3345	1	A D		.			
14	80A0B3345	1	B E		.			
14	80B0B3345	1	C		.			
14	80C0B3345	1	F		.			
15	8000B4129	1		.	.	.		
16	8000B2956	1		.				
16	80A0B2956	1			.			
16	8000B2956	1	B			.		
17	800089293	2		.	.	.		
18	8D00B2681	4		.	.	.		
19	8000B2955	1		.				
19	80A0B2955	1			.			
19	8000B2955	1	B			.		
20	800089784	1		.	.	.		
21	800089785	1		.	.	.		
22	80A090977	2		.	.	.		
23	800089293	2		.	.	.		
24	800099401	1		.	.	.		
25	8H00B2688	1		.	.	.		
26	8A00B2672	8		.	.	.		
27	8000B3202	1	A D	.				
27	80A0B3202	1	B E	.				
27	80B0B3202	1	C F	.				
27	8000B3518	1	A		.			
27	80A0B3518	1	B E		.			
27	80B0B3518	1	C		.			
27	80C0B3518	1	D		.			
27	80D0B3518	1	F		.			
27	8000B4599	1	A			.		
27	80A0B4599	1	B			.		
28	8B0092256	2		.	.	.		
29	800099326	1		.	.	.		
30	8A00B2681	2		.	.	.		
31	8000B2722	2		.	.	.		
32	80A098720	1		.	.	.		
33	8000A0903	1		.	.	.		
34	8000B4032	1		.	.			
34	8000B5779	1				.		
35	8000B2957	1		.				
35	80A0B2957	1	A D		.			
35	80B0B2957	1	B C E		.			
35	80C0B2957	1	F		.			



B5 990 R: A D Versione Rossa - Red version - Version Rouge - Rote Version - Versión Roja.
 B E Versione Nero - Black version - Version Noire - Schwarze Version - Versión Negra.
 C F Versione Bianco - White version - Version Blanche - Weiße Version - Versión Blanca.

B5 1090 RR: A D Versione Rosso/Argento - Red/Silver version - Version Rouge/Argent - Rot/Silber Version - Versión Rojo/Plata.
 B E Versione Bianco/Nero - White/Black version - Version Blanche/Noire - Weiße/Schwarze Version - Versión Blanca/Negra.
 C Versione Nero/Antracite - Black/Anthracite version - Version Noire/Anthracite - Schwarze/Anthrazit Version - Versión Negra/Antracita.
 F Versione Argento/Grigio Titanium - Silver/Titanium Grey version - Version Argent/Gris Titanium - Silber/Grau Titanium Version - Versión Plata/Gris Titanium.

BRUTALE: A Versione Nero Opaco - Matt Black version - Version Noire Mat - Matte Schwarze Version - Versión Negra Mate.
 B Versione Bianco Opaco - Matt White version - Version Blanche Mat - Matte Weiße Version - Versión Blanca Mate.

1 Esclusi gli USA (vedi tavola K02) - USA excluded (see table K02) - Sauf les USA (voir planche K02) - Ausschließlich USA (siehe Tafel K02) - Excluidos los USA (ver tabla K02).



ASSIEME SERBATOIO BENZINA
FUEL TANK ASSEMBLY • ENSEMBLE RÉSERVOIR DE CARBURANT
BAUGRUPPE TANK • CONJUNTO DEPÓSITO GASOLINA

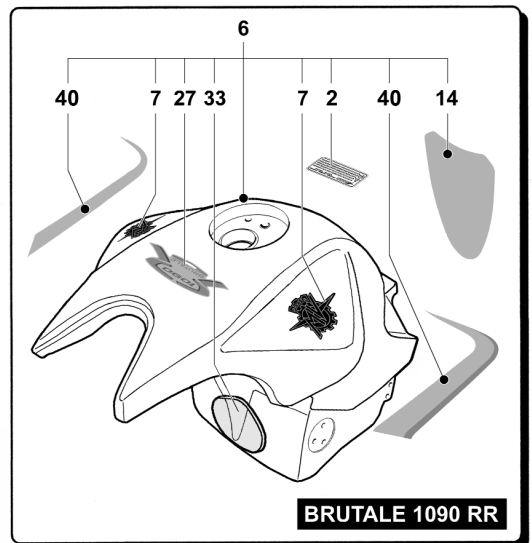

ASSIEME SERBATOIO BENZINA

 FUEL TANK ASSEMBLY • ENSEMBLE RÉSERVOIR DE CARBURANT
 BAUGRUPPE TANK • CONJUNTO DEPÓSITO GASOLINA

N.	Code	Q.ty	Note	Brutale 990 R	Brutale 1090 RR	Brutale	► I FRAME I ►	► I ENGINE I ►
35	8000B5777	1				•		
36	8000B2961	1		•		•		
36	80A0B2961	1			•			
37	8B0090901	6		•	•	•		
38	8000B2958	1		•				
38	80A0B2958	1	A D		•			
38	80B0B2958	1	B C E		•			
38	80C0B2958	1	F		•			
38	8000B5778	1				•		
39	8000B2962	1		•		•		
39	80A0B2962	1			•			
40	8000B4029	1	A		•			
40	80A0B4029	1	B C E		•			
40	80B0B4029	1	D		•			
40	80C0B4029	1	F		•			
41	800092882	6			•			



B5 1090 RR: **A D** Versione Rosso/Argento - Red/Silver version - Version Rouge/Argent - Rot/Silber Version - Versión Rojo/Plata.
B E Versione Bianco/Nero - White/Black version - Version Blanche/Noire - Weiße/Schwarze Version - Versión Blanca/Negra.
C Versione Nero/Antracite - Black/Anthracite version - Version Noire/Anthracite - Schwarze/Anthrazit Version - Versión Negra/Antracita.
F Versione Argento/Grigio Titanium - Silver/Titanium Grey version - Version Argent/Gris Titanium - Silber/Grau Titanium Version - Versión Plata/Gris Titanium.

E04

3



ASSIEME CODONE

REAR FAIRING ASSEMBLY • ENSEMBLE CARÉNAGE DE SELLE
BAUGRUPPE HECK • CONJUNTO COLÍN

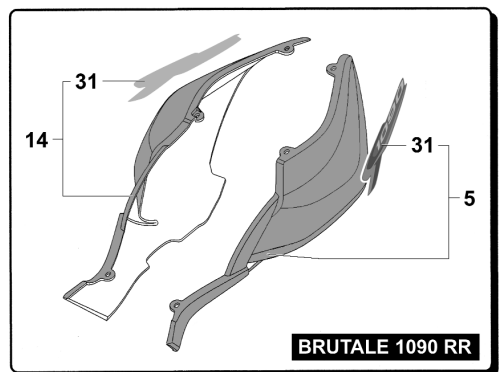
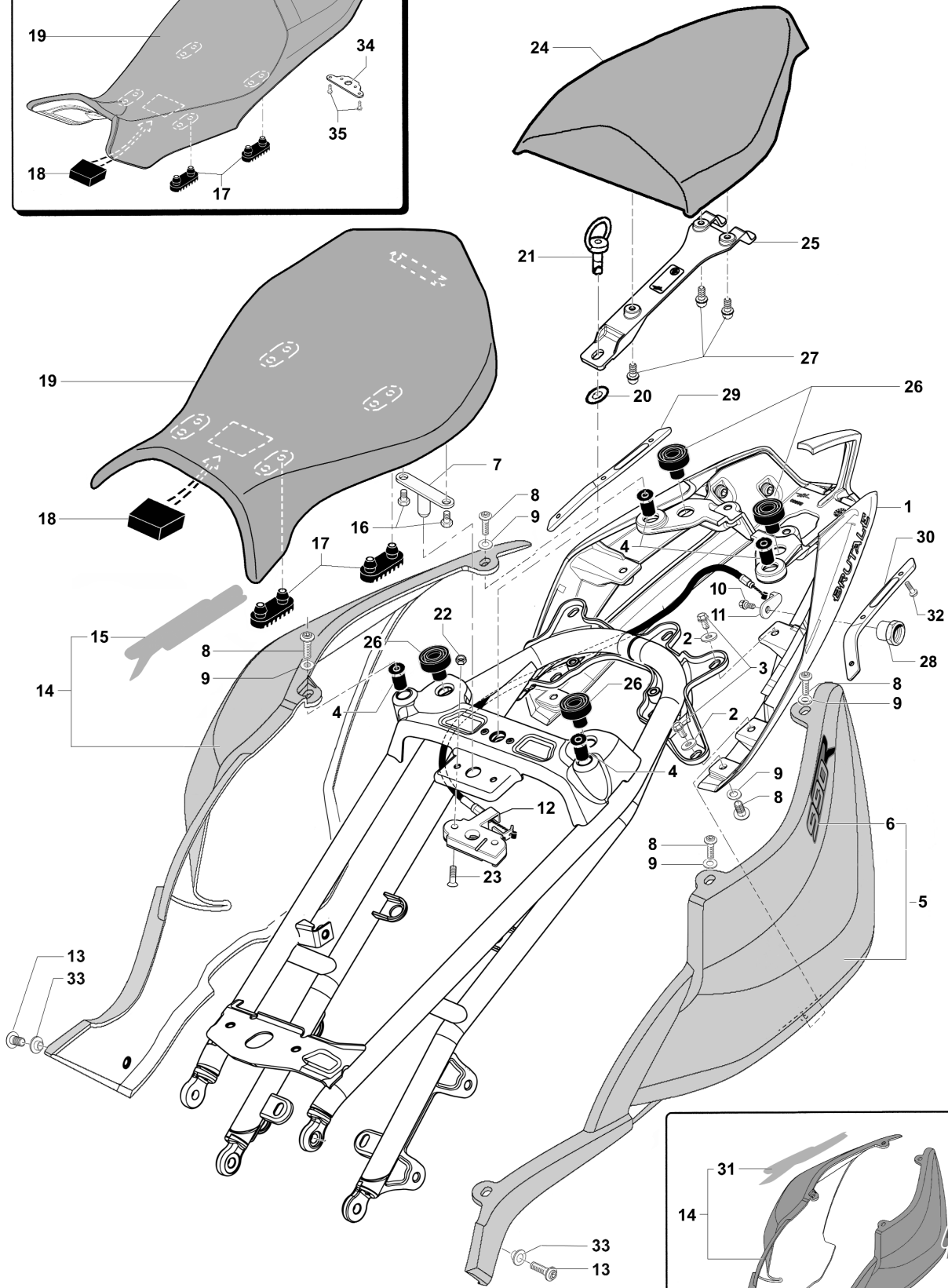
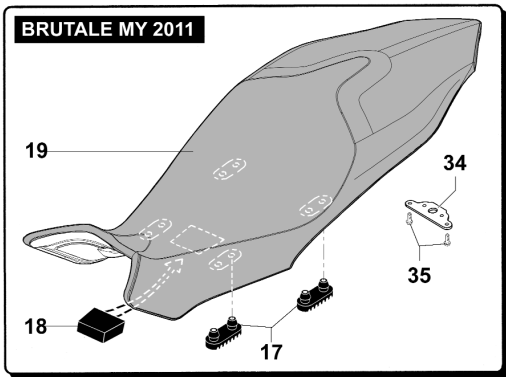

ASSIEME CODONE

 REAR FAIRING ASSEMBLY • ENSEMBLE CARÉNAGE DE SELLE
 BAUGRUPPE HECK • CONJUNTO COLÍN

N.	Code	Q.ty	Note	Brutale 990 R	Brutale 1090 RR	Brutale	► I FRAME I ►	► I ENGINE I ►
1	8000B2947	1	A B C	.				
1	80B0B2947	1	D E F	.				
1	80A0B2947	1			.			
1	8A00B4732	1				.		
2	80B004898	4		.	.	.		
3	8C00B2681	4		.	.	.		
4	800048245	4		.	.	.		
5	8000B3213	1	A D	.				
5	80A0B3213	1	B E	.				
5	80B0B3213	1	C F	.				
5	8000B3387	1	A		.			
5	80A0B3387	1	B E		.			
5	80B0B3387	1	C		.			
5	80C0B3387	1	D		.			
5	80D0B3387	1	F		.			
5	80G0B2963	1	A			.		
5	80H0B2963	1	B			.		
6	8000B3215	1	A D	.				
6	80A0B3215	1	B E	.				
6	80B0B3215	1	C F	.				
7	8000B2994	1		.	.			
8	8B00B2672	6		.	.	.		
9	800089751	6		.	.	.		
10	8C00B2680	1		.	.	.		
11	8000B3001	1		.	.	.		
12	8000B3006	1		.	.			
12	8B00B3006	1				.		
13	8A00B2672	2		.	.	.		
14	8000B3214	1	A D	.				
14	80A0B3214	1	B E	.				
14	80B0B3214	1	C F	.				
14	8000B3386	1	A		.			
14	80A0B3386	1	B E		.			
14	80B0B3386	1	C		.			
14	80C0B3386	1	D		.			
14	80D0B3386	1	F		.			
14	80G0B2964	1	A			.		
14	80H0B2964	1	B			.		
15	8000B3215	1	A D	.				
15	80A0B3215	1	B E	.				
15	80B0B3215	1	C F	.				
16	8A00B2681	2		.	.			
17	800090380	4		.	.	.		
18	8000B2970	1		.	.	.		
19	8000B2968	1		.	.			
19	8000B4745	1				.		
20	800069149	1		.	.			
21	80A069148	1		.	.			



B5 990 R: **A D** Versione Rossa - Red version - Version Rouge - Rote Version - Versión Roja.
B E Versione Nero - Black version - Version Noire - Schwarze Version - Versión Negra.
C F Versione Bianco - White version - Version Blanche - Weiße Version - Versión Blanca.

B5 1090 RR: **A D** Versione Rosso/Argento - Red/Silver version - Version Rouge/Argent - Rot/Silber Version - Versión Rojo/Plata.
B E Versione Bianco/Nero - White/Black version - Version Blanche/Noire - Weiße/Schwarze Version - Versión Blanca/Negra.
C Versione Nero/Antracite - Black/Anthracite version - Version Noire/Anthracite - Schwarze/Anthrazit Version - Versión Negra/Antracita.
F Versione Argento/Grigio Titanium - Silver/Titanium Grey version - Version Argent/Gris Titanium - Silber/Grau Titanium Version - Versión Plata/Gris Titanium.

BRUTALE: **A** Versione Nero Opaco - Matt Black version - Version Noire Mat - Matte Schwarze Version - Versión Negra Mate.
B Versione Bianco Opaco - Matt White version - Version Blanche Mat - Matte Weiße Version - Versión Blanca Mate.



ASSIEME CODONE

REAR FAIRING ASSEMBLY • ENSEMBLE CARÉNAGE DE SELLE
BAUGRUPPE HECK • CONJUNTO COLÍN

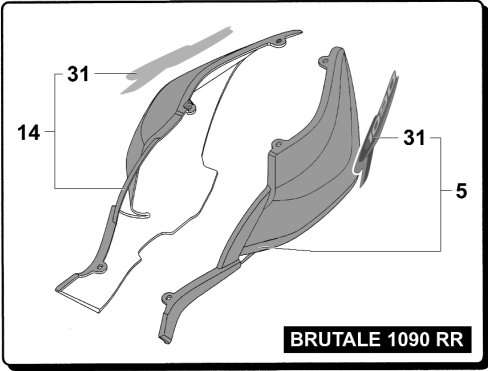
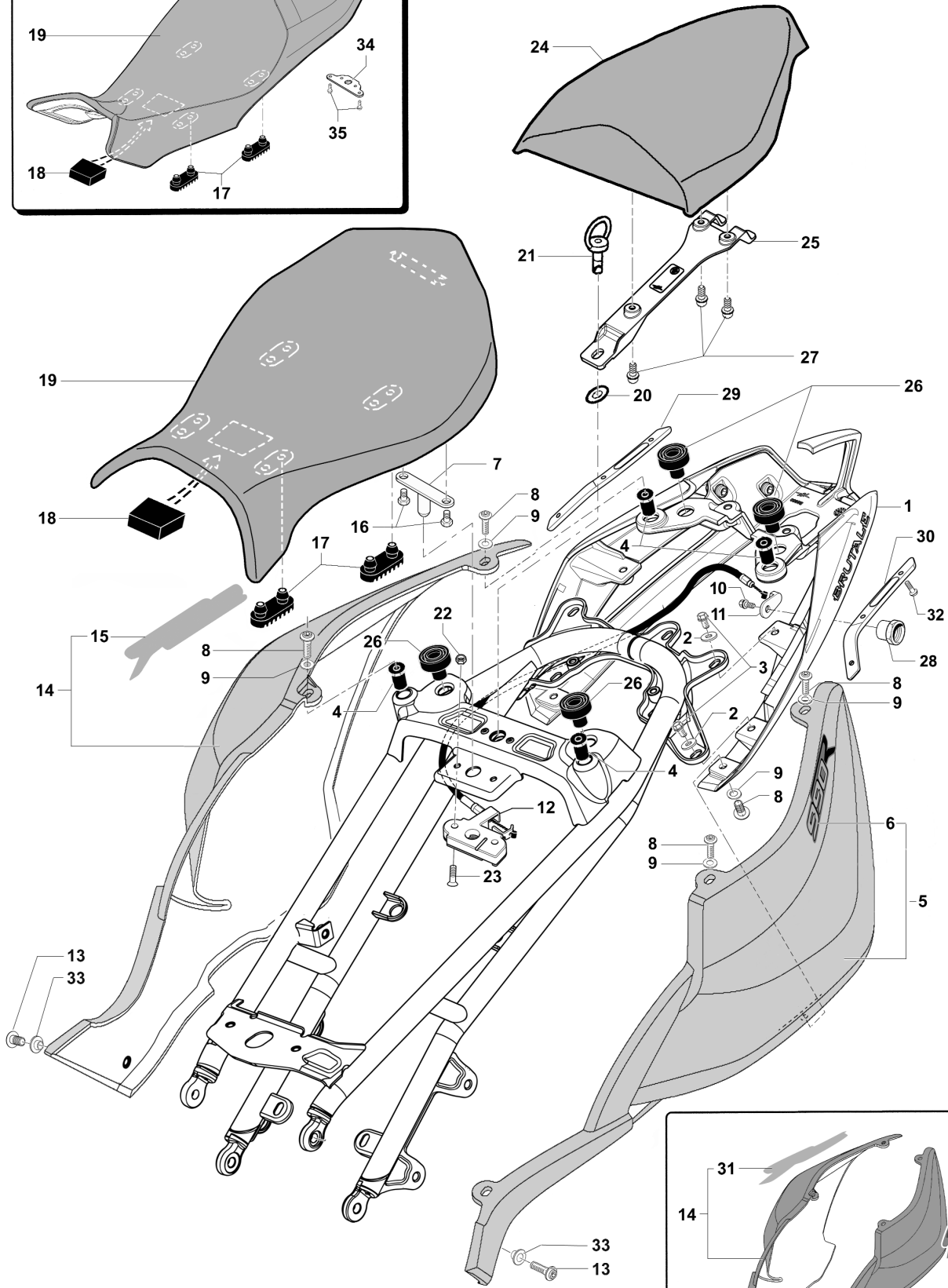
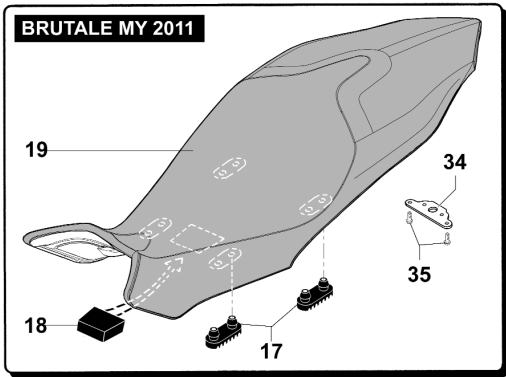

ASSIEME CODONE

 REAR FAIRING ASSEMBLY • ENSEMBLE CARÉNAGE DE SELLE
 BAUGRUPPE HECK • CONJUNTO COLÍN

N.	Code	Q.ty	Note	Brutale 990 R	Brutale 1090 RR	Brutale	► I FRAME I ►	► I ENGINE I ►
22	8000B2707	2		•	•	•		
23	8E00B2694	2		•	•			
23	8F00B2694	2				•		
24	8000B2971	1	A D	•				
24	80A0B2971	1	B C E F	•				
24	80B0B2971	1	A D F		•			
24	80A0B2971	1	B C E		•			
25	8000B3007	1		•	•			
26	800041039	4		•	•	•		
27	8000B2688	3		•	•			
28	8000B3143	1		•	•	•		
29	8000B3870	1		•	•			
29	8000B4406	1				•		
30	8000B3871	1		•	•			
30	8000B4407	1				•		
31	8000B4030	1	A		•			
31	80A0B4030	1	B E		•			
31	80B0B4030	1	C		•			
31	80C0B4030	1	D		•			
31	80D0B4030	1	F		•			
32	8000B4115	6		•	•	•		
33	80A092670	2		•	•	•		
34	8000B4455	1				•		
35	8E00B2680	2				•		

B5 990 R: **A D** Versione Rossa - Red version - Version Rouge - Rote Version - Versión Roja.
B E Versione Nero - Black version - Version Noire - Schwarze Version - Versión Negra.
C F Versione Bianco - White version - Version Blanche - Weiße Version - Versión Blanca.

B5 1090 RR: **A D** Versione Rosso/Argento - Red/Silver version - Version Rouge/Argent - Rot/Silber Version - Versión Rojo/Plata.
B E Versione Bianco/Nero - White/Black version - Version Blanche/Noire - Weiße/Schwarze Version - Versión Blanca/Negra.
C Versione Nero/Antracite - Black/Anthracite version - Version Noire/Anthracite - Schwarze/Anthrazit Version - Versión Negra/Antracita.
F Versione Argento/Grigio Titanium - Silver/Titanium Grey version - Version Argent/Gris Titanium - Silber/Grau Titanium Version - Versión Plata/Gris Titanium.





IMPIANTO ELETTRICO

ELECTRIC SYSTEM • INSTALLATION ÉLECTRIQUE
ELEKTRISCHE ANLAGE • INSTALACIÓN ELÉCTRICA

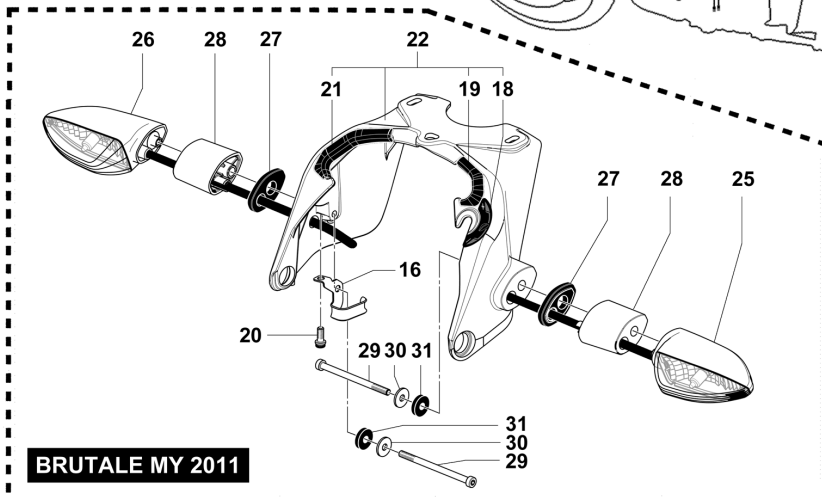
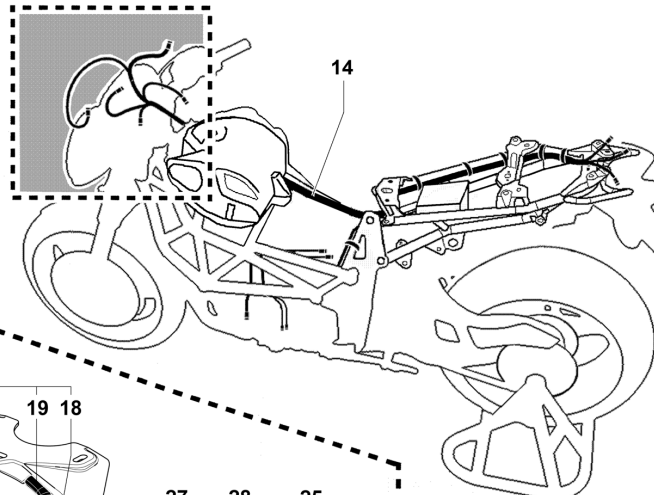
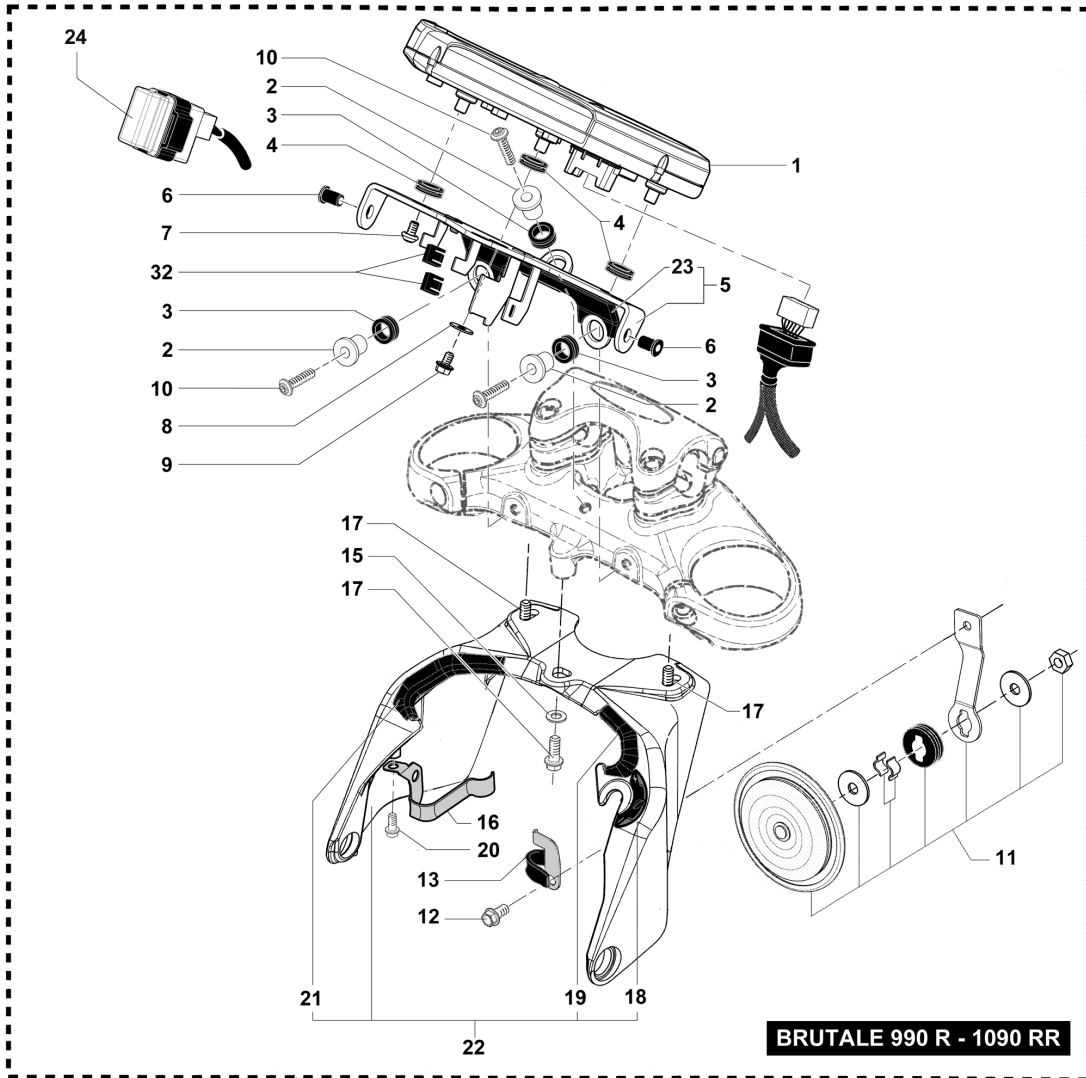

IMPIANTO ELETTRICO

ELECTRIC SYSTEM • INSTALLATION ÉLECTRIQUE
ELEKTRISCHE ANLAGE • INSTALACIÓN ELÉCTRICA



N.	Code	Q.ty	Note	Brutale 990 R	Brutale 1090 RR	Brutale	► I FRAME I ►	► I ENGINE I ►
1	8000B0910	1		•	•	•		
2	8000B2799	3		•	•	•		
3	800089293	3		•	•	•		
4	800090239	3		•	•	•		
5	8000B3028	1		•	•			
5	8000B5299	1				•		
6	800091022	2		•	•	•		
7	800092659	2		•	•	•		
8	62ND15548	1		•	•	•		
9	8A00B2680	1		•	•	•		
10	8B00B2672	3		•	•	•		
11	800099114	1		•	•	•		
12	8B00B2681	1		•	•	•		
13	8000B4347	1		•	•	•		
14	8000B3204	1		•	•			
14	8000B4909	1				•		
15	80B004898	3		•	•	•		
16	8000B4218	1		•	•			
16	8000B5205	1				•		
17	8D00B2681	3		•	•	•		
18	8000B3210	1		•	•	•		
19	800098847	1		•	•	•		
20	8B00B2687	1		•	•	•		
21	800098846	1		•	•	•		
22	8000B3381	1		•				
22	8A00B3381	1	USA MY 2011	•				
22	8000B3381	1	A B C		•			
22	8A00B3381	1	A B C		•			
22	80A0B3381	1	USA MY 2011					
22	80A0B3381	1	D E F		•			
22	8AA0B3381	1	D E F		•			
22	8000B4944	1	USA MY 2011			•		
23	8000B4248	1		•	•	•		
24	8000B3217	1		•	•			
24	8000B4948	1				•		
25	8000B5172	1				•		
26	8000B5173	1				•		
27	8000B4740	2				•		
28	8000B4728	2				•		
28	8A00B4728	2	USA			•		
29	8000B5435	2				•		
29	8A00B5435	2	USA			•		
30	800060910	2				•		
31	8000B5721	2				•		
32	8000B5301	2				•		



PROIETTORE ANTERIORE
FRONT HEADLIGHT • PROJECTEUR AVANT
SCHEINWERFER • PROYECTOR DELANTERO

BRUTALE 990 R - 1090 RR

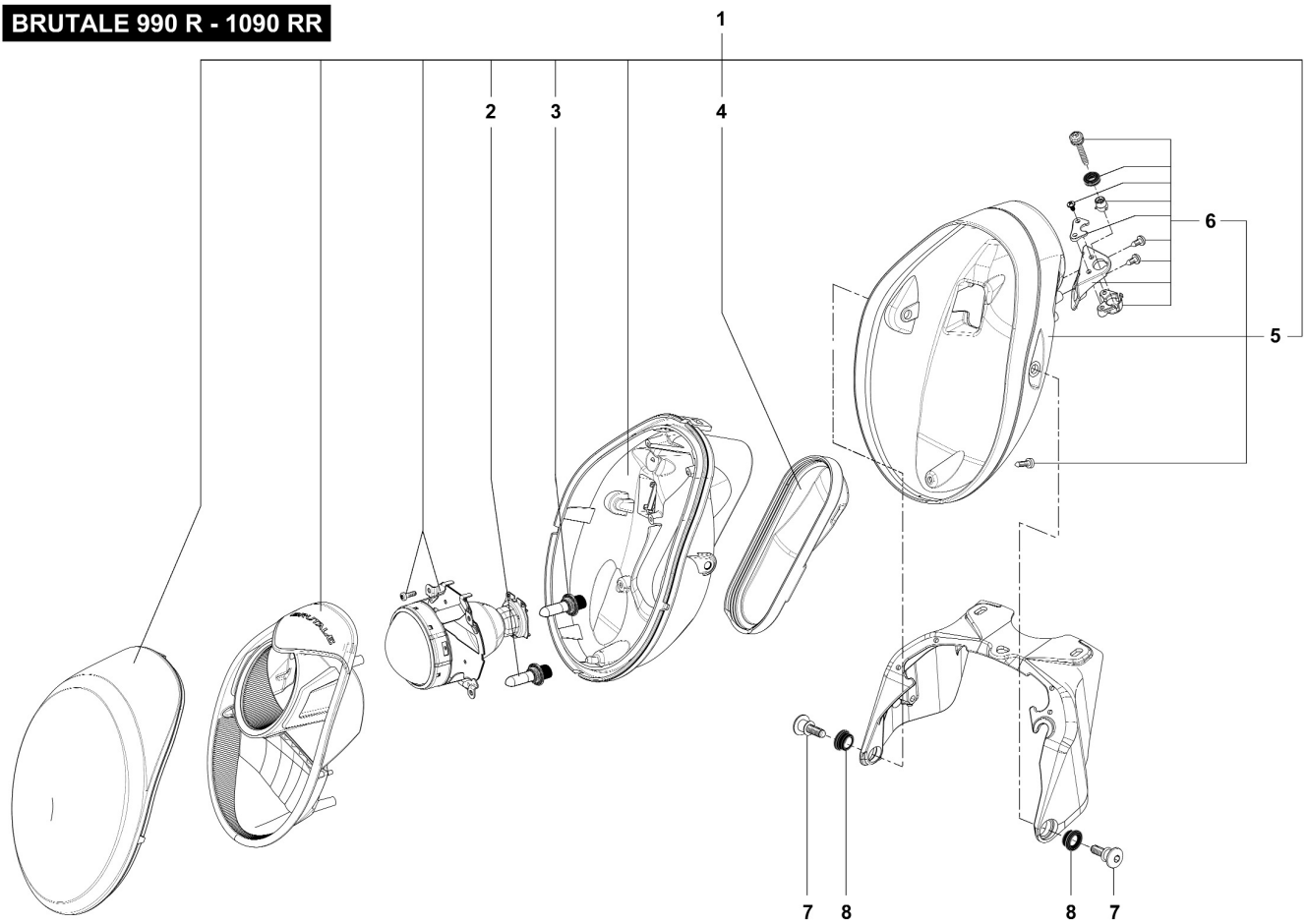

BRUTALE MY 2011

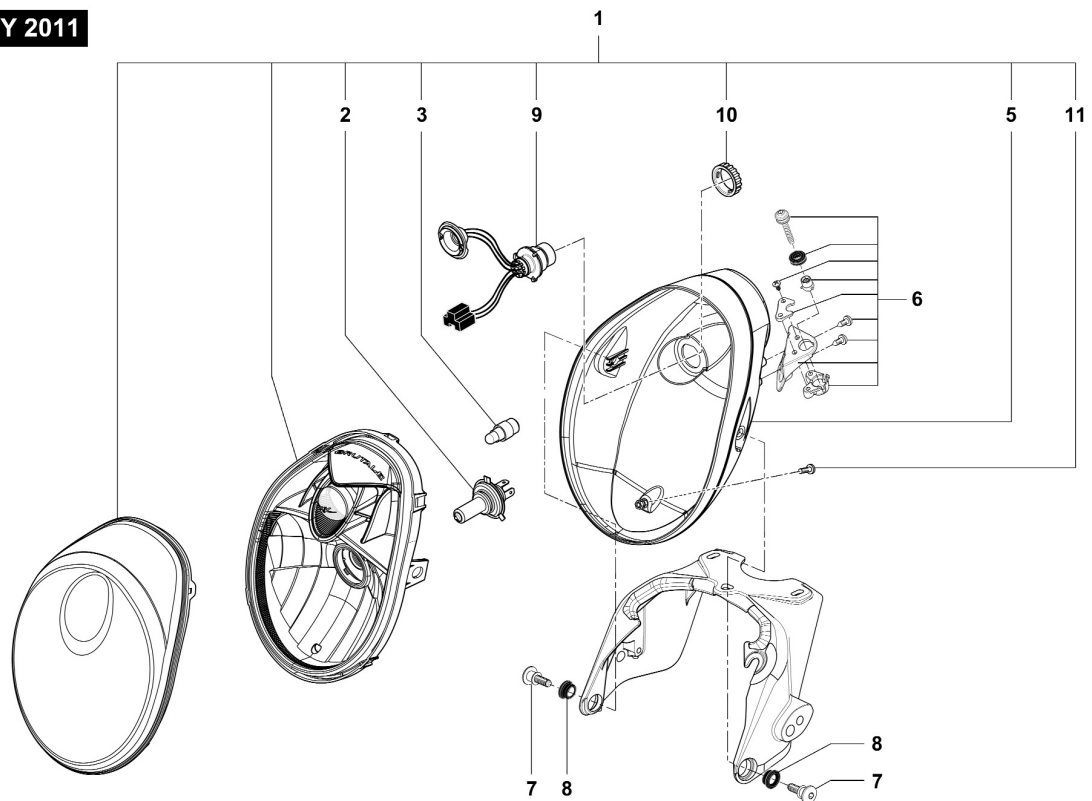

PROIETTORE ANTERIORE

FRONT HEADLIGHT • PROJECTEUR AVANT
SCHEINWERFER • PROYECTOR DELANTERO



N.	Code	Q.ty	Note	Brutale 990 R	Brutale 1090 RR	Brutale	► I FRAME I ►	► I ENGINE I ►
1	8000B1508	1	①	•	•			
1	8000B3243	1	②	•	•			
1	8000B3244	1	USA	•	•			
1	8000B4744	1				•		
2	8000B4291	1		•	•			
2	8000B5711	1				•		
3	8000B4291	1		•	•			
3	8000B5710	1				•		
4	8000B4292	1		•	•			
5	8000B4293	1		•	•			
5	8000B5708	1				•		
6	8000B3444	1		•	•	•		
7	8000B3089	2		•	•	•		
8	8A0097112	2		•	•	•		
9	8000B5700	1				•		
10	8000B5713	1				•		
11	8000B5712	1				•		

- ① Per guida a destra - For right-hand drive - Pour conduite à droite - Für Rechtslenkung - Para conducción a la derecha
 ② Per guida a sinistra - For left-hand drive - Pour conduite à gauche - Für Linkslenkung - Para conducción a la izquierda



IMPIANTO ELETTRICO
ELECTRIC SYSTEM • INSTALLATION ÉLECTRIQUE
ELEKTRISCHE ANLAGE • INSTALACIÓN ELÉCTRICA

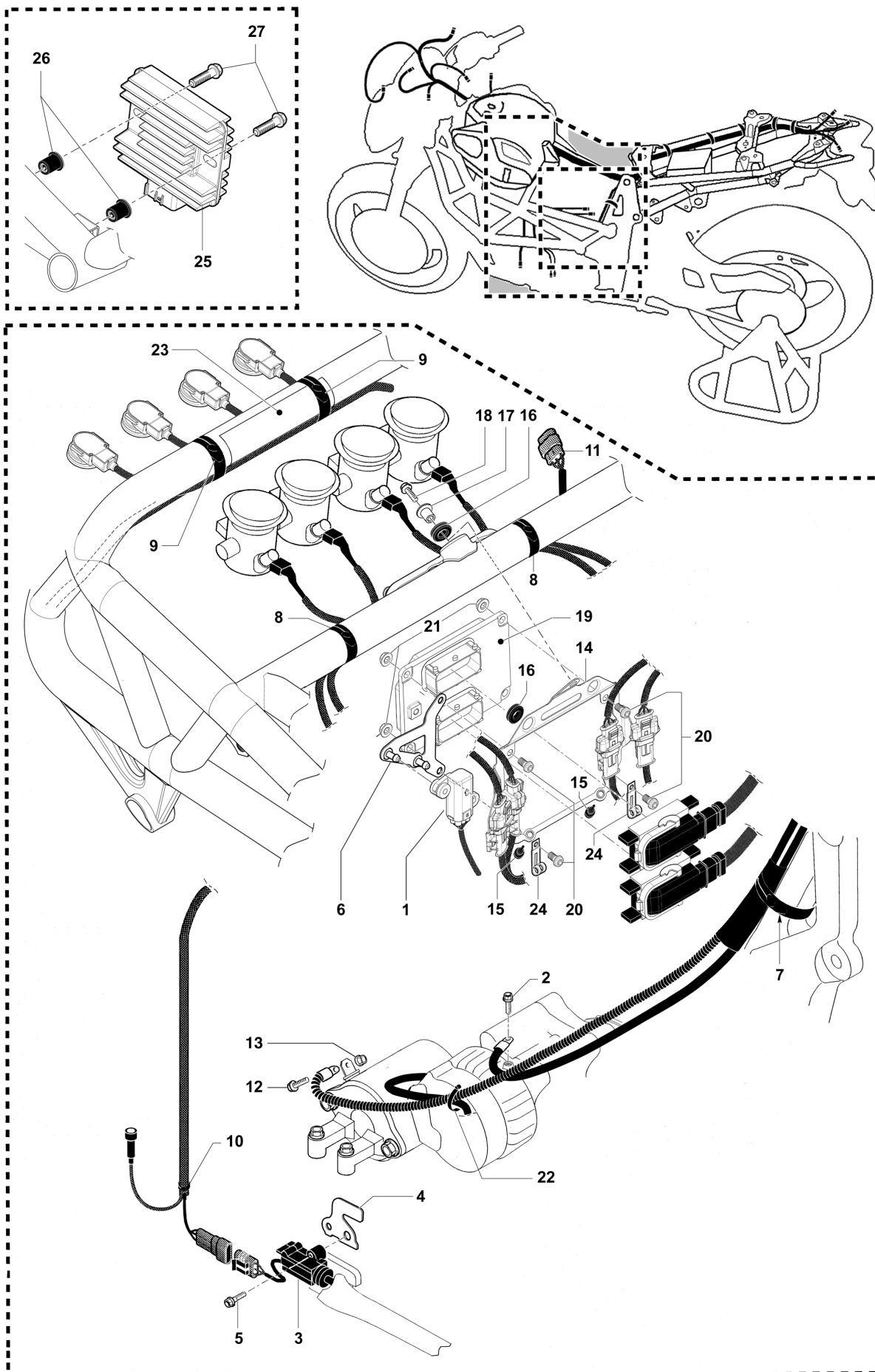

IMPIANTO ELETTRICO

ELECTRIC SYSTEM • INSTALLATION ÉLECTRIQUE
ELEKTRISCHE ANLAGE • INSTALACIÓN ELÉCTRICA



N.	Code	Q.ty	Note	Brutale 990 R	Brutale 1090 RR	Brutale	► I FRAME I ►	► I ENGINE I ►
1	8000A6408	1		•	•	•		
2	8000B2682	1		•	•	•		
3	800090375	1		•	•	•		
4	80A091653	1		•	•	•		
5	8F00B2687	2		•	•	•		
6	8000B2996	1		•	•	•		
7	800092247	1		•	•	•		
8	800092247	2		•	•	•		
9	800092248	2		•	•	•		
10	800092668	1		•	•	•		
11	8B0089516	1		•	•	•		
12	8A00B2680	1		•	•	•		
13	8000B2708	1		•	•	•		
14	8A00A9036	1		•	•	•		
15	800099419	2		•	•	•		
16	800089293	3		•	•	•		
17	8000B2799	1		•	•	•		
18	8D00B2681	1		•	•	•		
19	8000B3218	1		•				
19	8A00B3218	1	F	•				
19	8B00B3218	1	JPN	•				
19	8E00B3218	1	USA	•				
19	8000B3344	1			•			
19	8A00B3344	1	F		•			
19	8B00B3344	1	JPN		•			
19	8F00B3344	1	USA		•			
19	8000B4767	1				•		
19	8A00B4767	1	F			•		
19	8B00B4767	1	JPN			•		
19	8F00B4767	1	USA			•		
20	8B00B2688	4		•	•	•		
21	8000B2711	4		•	•	•		
22	800056783	1		•	•	•		
23	8000B4536	1		•	•	•		
24	8000A1792	2		•	•	•		
25	8000B3206	1		•	•	•		
26	800048245	2		•	•	•		
27	8G00B2681	2		•	•	•		



IMPIANTO ELETTRICO
ELECTRIC SYSTEM • INSTALLATION ÉLECTRIQUE
ELEKTRISCHE ANLAGE • INSTALACIÓN ELÉCTRICA

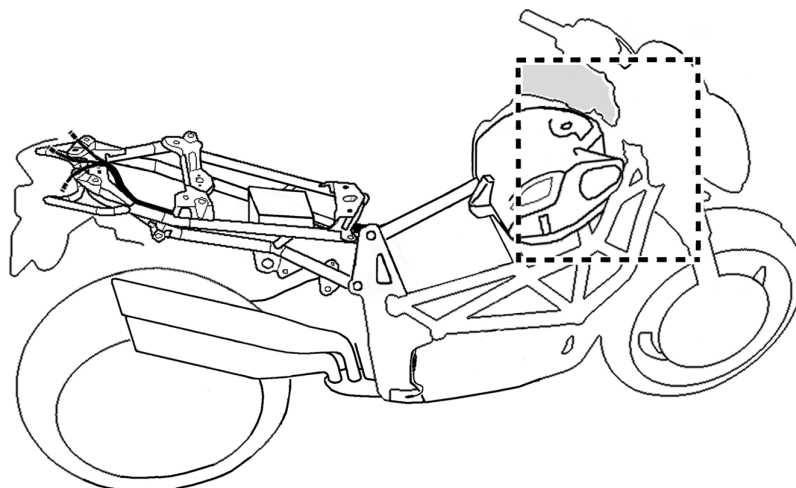
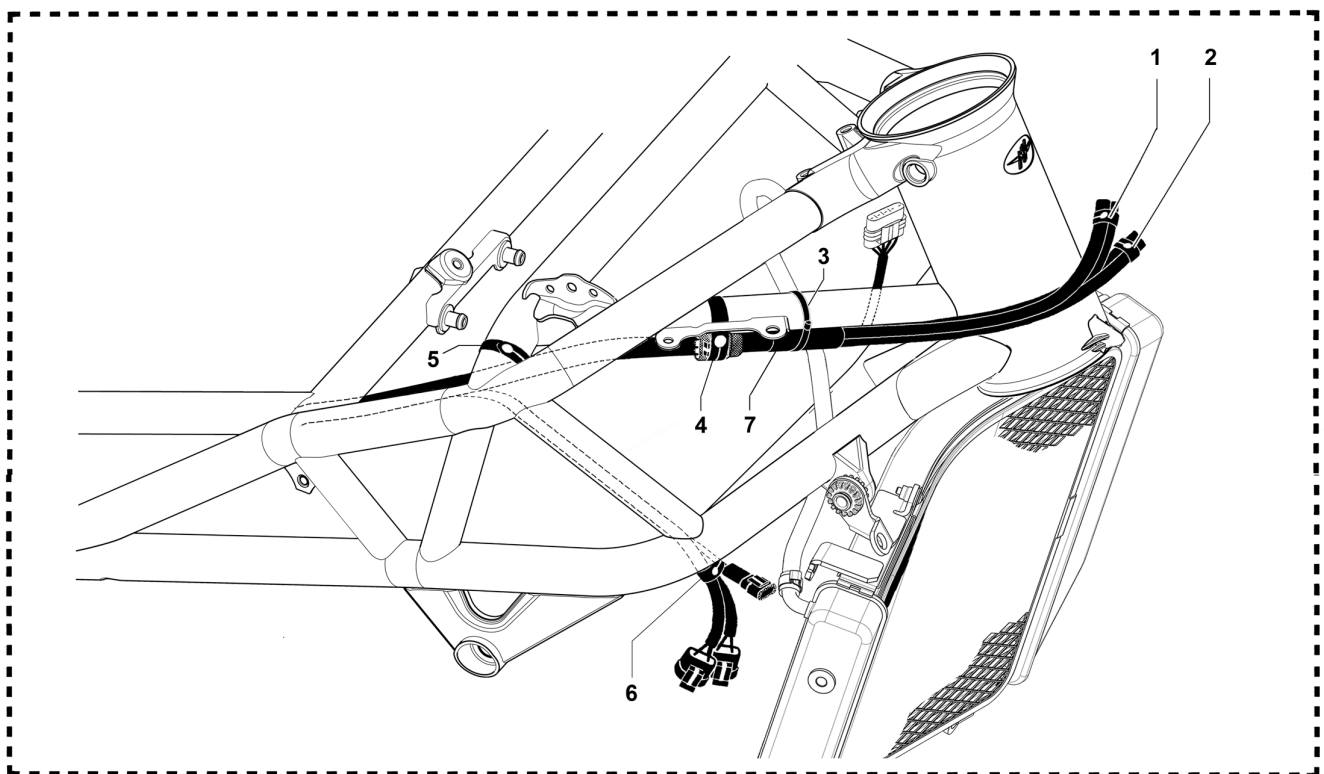
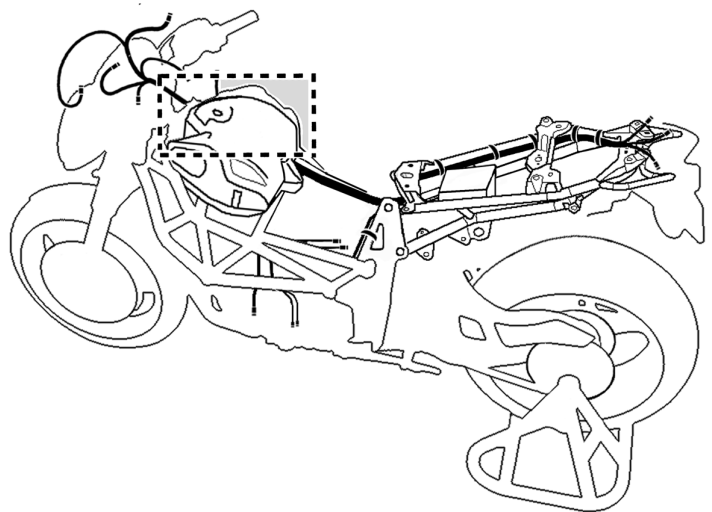
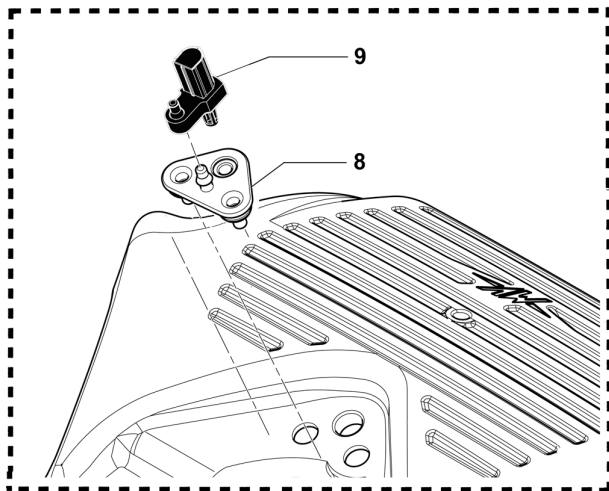

IMPIANTO ELETTRICOELECTRIC SYSTEM • INSTALLATION ÉLECTRIQUE
ELEKTRISCHE ANLAGE • INSTALACIÓN ELÉCTRICA

N.	Code	Q.ty	Note	Brutale 990 R	Brutale 1090 RR	Brutale	► I FRAME I ►	► I ENGINE I ►
1	800053724	1		•	•	•		
2	800053724	1		•	•	•		
3	800056444	1		•	•	•		
4	800092248	1		•	•	•		
5	800092248	1		•	•	•		
6	800092668	1		•	•	•		
7	800090417	1		•	•	•		
8	8000B3219	1		•	•	•		
9	8000B3207	1		•	•	•		



IMPIANTO ELETTRICO

ELECTRIC SYSTEM • INSTALLATION ÉLECTRIQUE
ELEKTRISCHE ANLAGE • INSTALACIÓN ELÉCTRICA

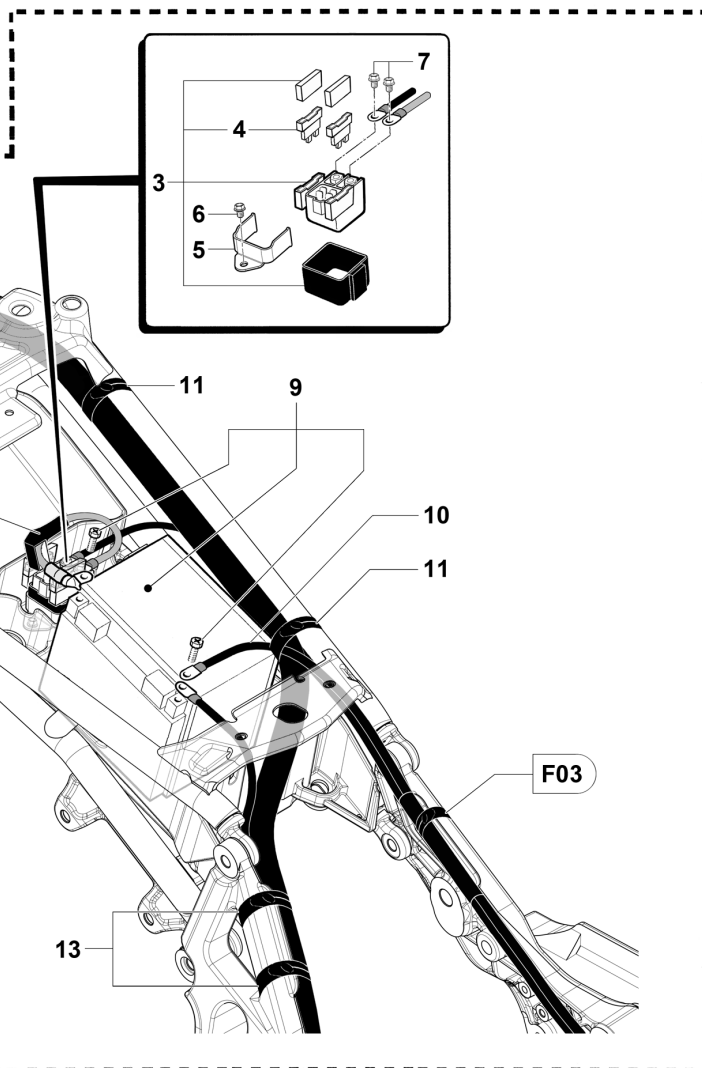
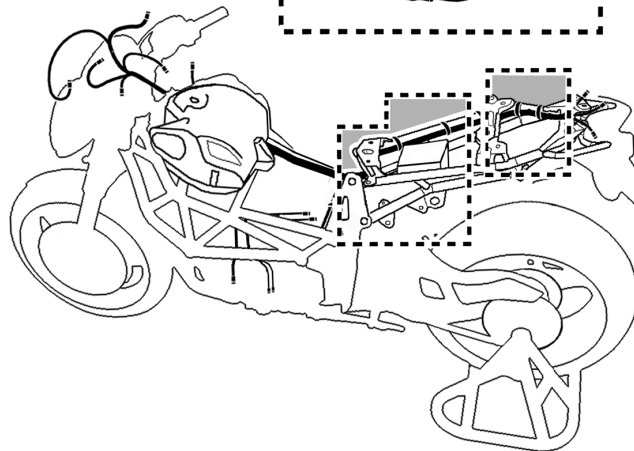
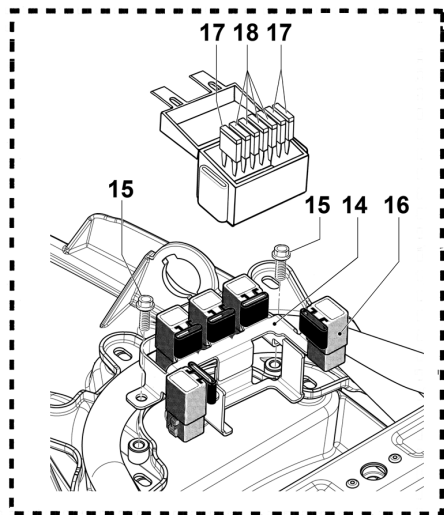
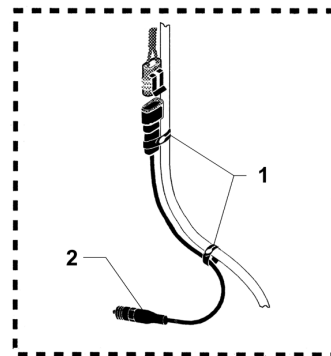
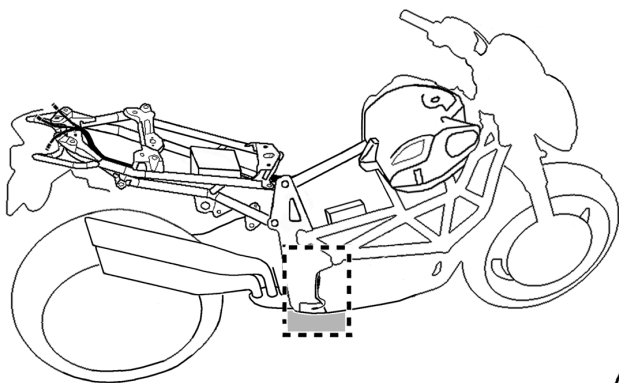

IMPIANTO ELETTRICOELECTRIC SYSTEM • INSTALLATION ÉLECTRIQUE
ELEKTRISCHE ANLAGE • INSTALACIÓN ELÉCTRICA

N.	Code	Q.ty	Note	Brutale 990 R	Brutale 1090 RR	Brutale	► I FRAME I ►	► I ENGINE I ►
1	800053724	2		•	•	•		
2	800090213	1		•	•	•		
3	8000A5350	1		•	•	•		
4	800093018	2		•	•	•		
5	80A099276	1		•	•	•		
6	8000B2681	1		•	•	•		
7	8000B2681	2		•	•	•		
8	8000B3109	1		•	•	•		
9	8000B3205	1		•	•	•		
10	8000B3108	1		•	•	•		
11	800092247	2		•	•	•		
12	800053724	1		•	•	•		
13	800092248	3		•	•	•		
14	8000B2998	1		•	•	•		
15	8000B2681	2		•	•	•		
16	8000A6749	5		•	•	•		
17	8F0099274	3		•	•	•		
18	8D0099274	4		•	•	•		



IMPIANTO ELETTRICO
ELECTRIC SYSTEM • INSTALLATION ÉLECTRIQUE
ELEKTRISCHE ANLAGE • INSTALACIÓN ELÉCTRICA

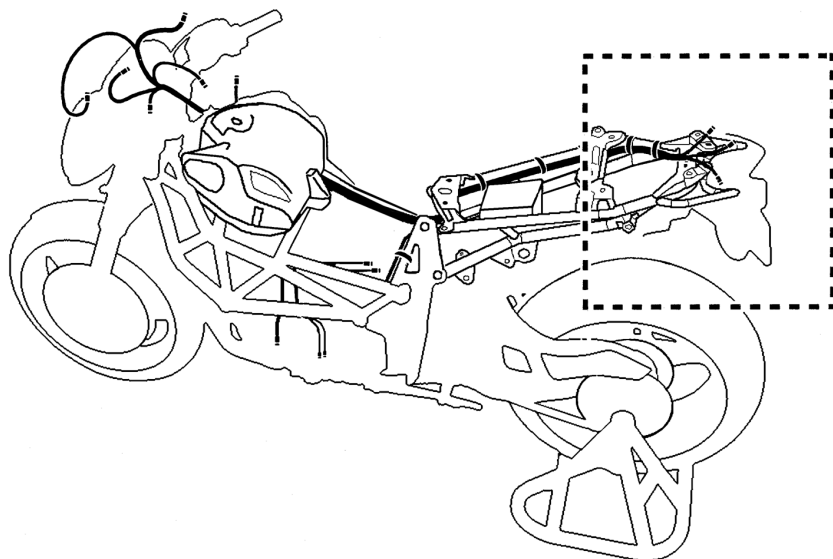
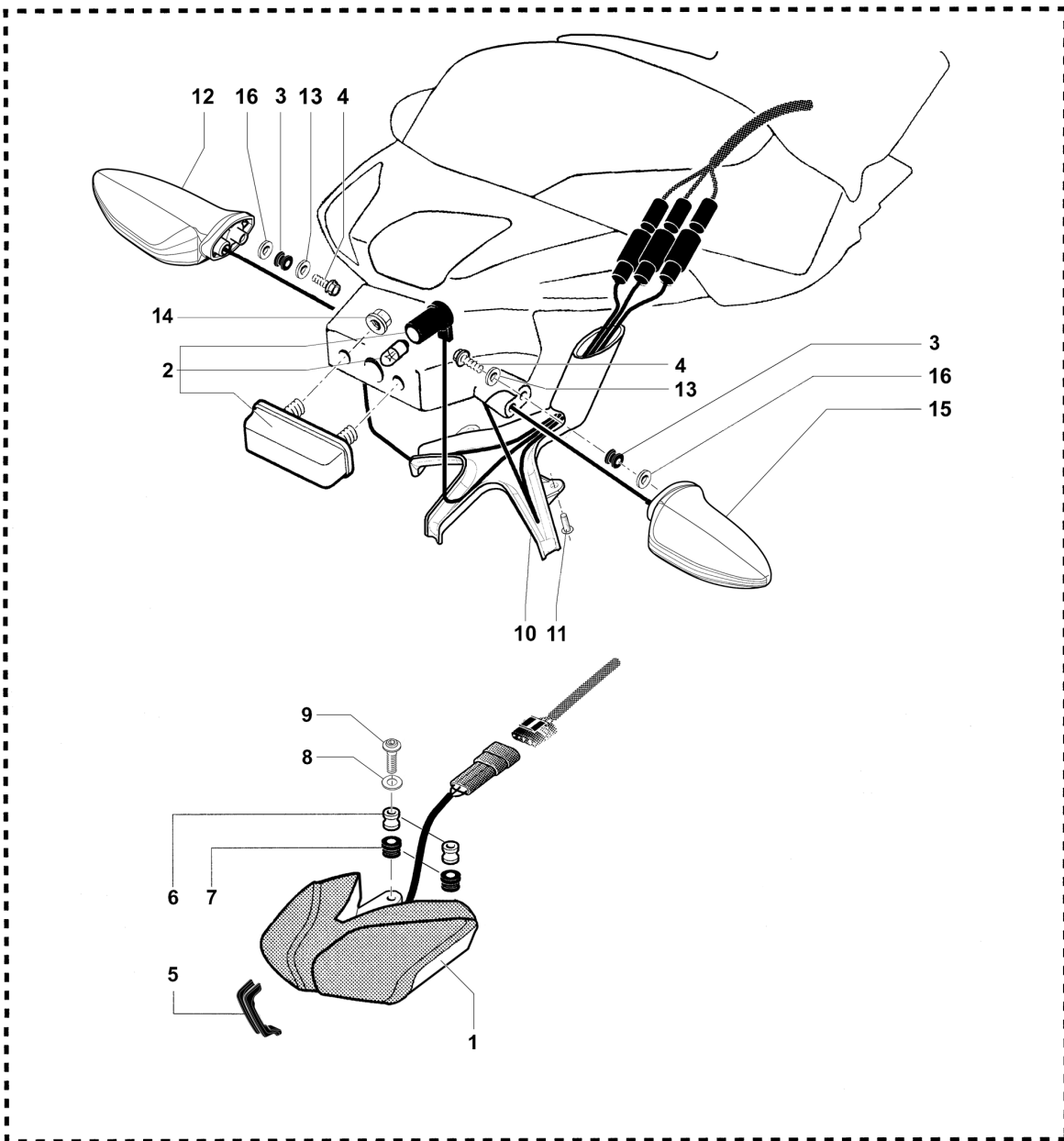

IMPIANTO ELETTRICO

ELECTRIC SYSTEM • INSTALLATION ÉLECTRIQUE
ELEKTRISCHE ANLAGE • INSTALACIÓN ELÉCTRICA



N.	Code	Q.ty	Note	Brutale 990 R	Brutale 1090 RR	Brutale	► I FRAME I ►	► I ENGINE I ►
1	8000B2988	1		•	•	•		
2	8000B3493	1		•	•	•		
3	8000B3118	2		•	•	•		
4	8B00B2680	2		•	•	•		
5	8000B2999	1		•	•	•		
6	8000A1873	2		•	•	•		
7	800090239	2		•	•	•		
8	8000B2722	2		•	•	•		
9	8B00B2672	2		•	•	•		
10	800099391	1		•	•	•		
11	8B0090901	2		•	•	•		
12	8000B3117	1		•	•			
12	8A00B3117	1	USA	•	•			
12	8000B5173	1				•		
13	62ND15548	2		•	•	•		
14	8000B2707	1		•	•	•		
15	8000B3117	1		•	•			
15	8A00B3117	1	USA	•	•			
15	8000B5172	1				•		
16	8000B2724	2				•		



ASSIEME CARTER MOTORE

CRANKCASE ASSEMBLY • ENSEMBLE CARTER DU MOTEUR
BAUGRUPPE MOTORGEHÄUSE • CONJUNTO CARTER MOTOR

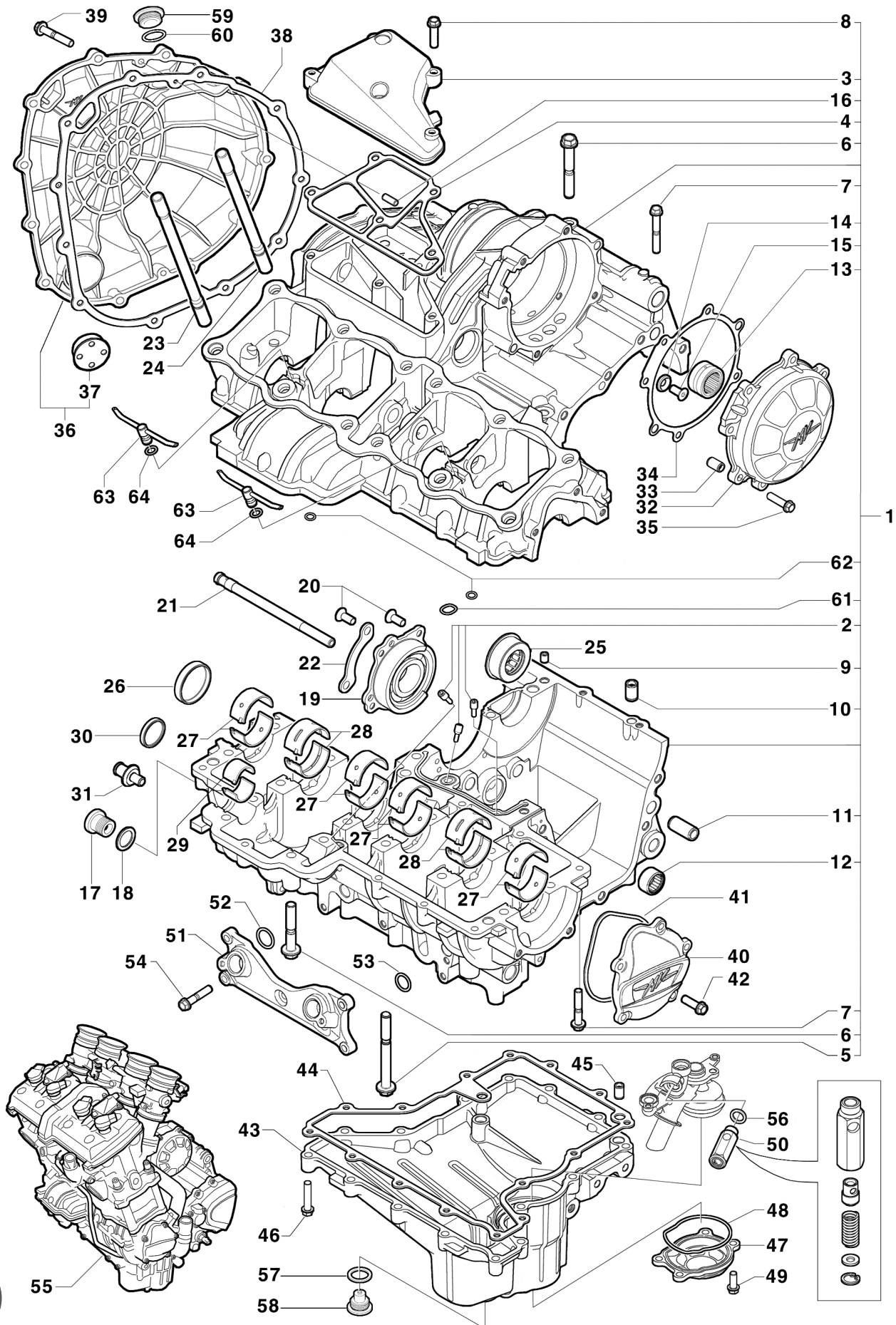

ASSIEME CARTER MOTORE

 CRANKCASE ASSEMBLY • ENSEMBLE CARTER DU MOTEUR
 BAUGRUPPE MOTORGEHÄUSE • CONJUNTO CÁRTER MOTOR

N.	Code	Q.ty	Note	Brutale 990 R	Brutale 1090 RR	Brutale	► I FRAME I ►	► I ENGINE I ►
1	8000B3283	1		•	•			
1	8000B5027	1				•		
2	8B00B2807	3		•	•			
3	8C0092465	1		•	•			
4	8000B4019	1		•	•			
5	8B00B2684	13		•	•			
6	8A00B2684	7		•	•			
7	8J00B2681	12		•	•			
8	8G00B2681	5		•	•			
9	800007719	3		•	•			
10	8A0051549	1		•	•			
11	800086119	3		•	•			
12	800087300	1		•	•			
13	800081422	1		•	•			
14	800086737	1		•	•			
15	8B00B2695	1		•	•			
16	8C0019590	2		•	•			
17	8000B2746	2		•	•			
18	800089426	2		•	•			
19	8000B2532	1		•	•			
20	8C00B2695	6		•	•			
21	8000B2063	1		•	•			
22	8000B2560	1		•	•			
23	8000A2170	6		•	•			
24	8000A2171	6		•	•			
25	8000A1087	1		•	•			
26	800081412	1		•	•			
27	800081317	8	①	•	•			
27	8A0081317	8	②	•	•			
27	8B0081317	8	③	•	•			
28	800081316	4	①	•	•			
28	8A0081316	4	②	•	•			
28	8B0081316	4	③	•	•			
29	8000B2065	4		•	•			
30	800035728	1		•	•			
31	8000B3014	1		•	•			
32	80A0B2004	1		•	•			
33	800051549	2		•	•			
34	8000B2066	1		•	•			
35	8G00B2681	7		•	•			
36	8000B3288	1		•	•			
37	800073529	1		•	•			
38	800080691	1		•	•			
39	8E00B2681	11		•	•			
40	80A0B3290	1		•	•			
41	800094626	1		•	•			
42	8E00B2681	5		•	•			
43	80A0B3291	1		•	•			
44	8000B3455	1		•	•			
45	800007719	2		•	•			
46	8H00B2681	15		•	•			
47	80A0B5295	1		•	•			
48	8000B3457	1		•	•			
49	8C00B2681	4		•	•			
50	8000B4619	1		•	•			

- ① Semicuscinetto rosso • Red half bearing • Demi-coussinet rouge • Halblager rot • Semicojinete rojo
 ② Semicuscinetto blu • Blue half bearing • Demi-coussinet bleu • Halblager blau • Semicojinete azul
 ③ Semicuscinetto giallo • Yellow half bearing • Demi-coussinet jaune • Halblager gelb • Semicojinete amarillo



G01

2

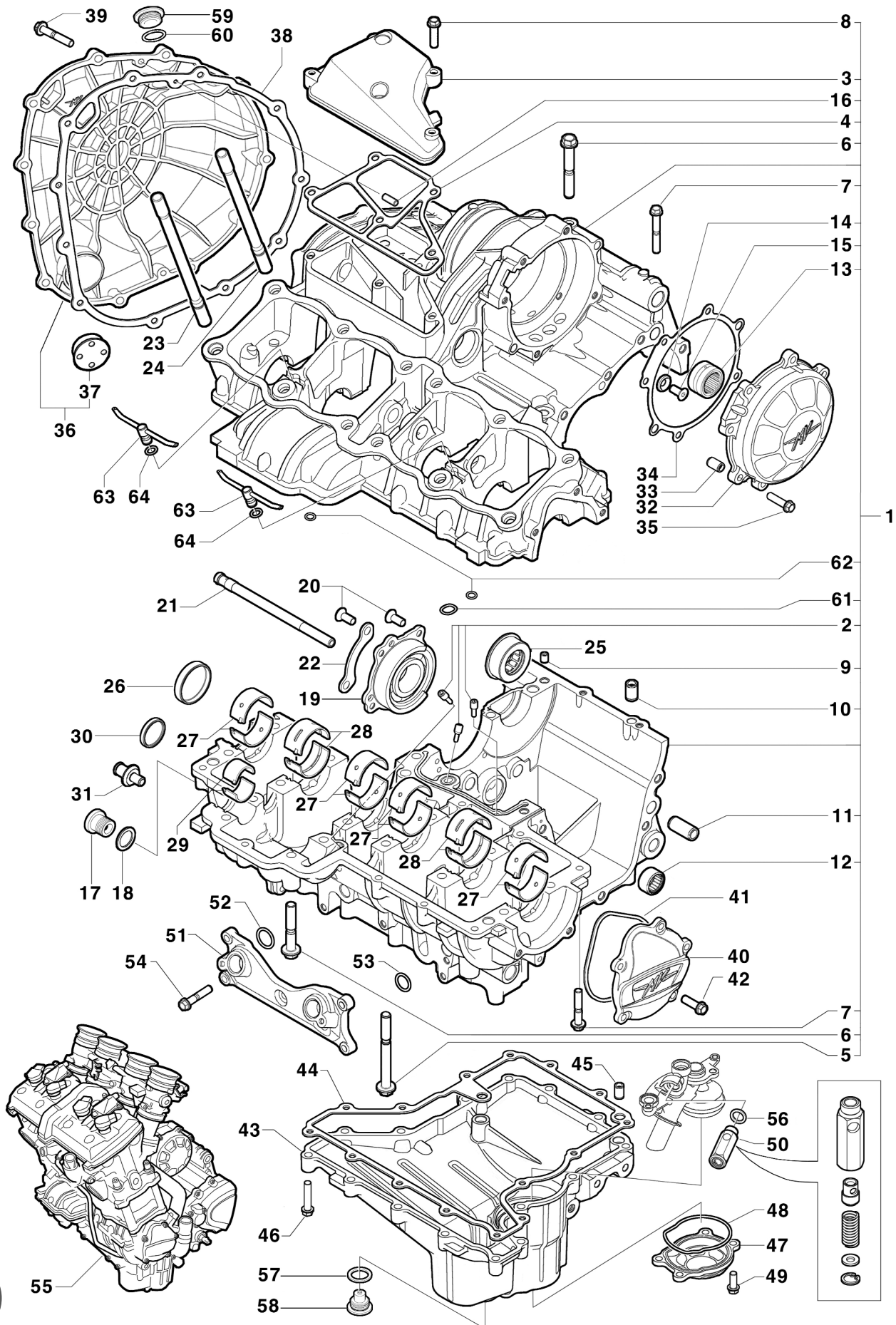

ASSIEME CARTER MOTORE

CRANKCASE ASSEMBLY • ENSEMBLE CARTER DU MOTEUR
BAUGRUPPE MOTORGEHÄUSE • CONJUNTO CÁRTER MOTOR



ASSIEME CARTER MOTORECRANKCASE ASSEMBLY • ENSEMBLE CARTER DU MOTEUR
BAUGRUPPE MOTORGEHÄUSE • CONJUNTO CÁRTER MOTOR

N.	Code	Q.ty	Note	Brutale 990 R	Brutale 1090 RR	Brutale	► I FRAME I ►	► I ENGINE I ►
51	80A0B3092	1		•	•	•		
52	8A0023111	1		•	•	•		
53	8A00A0819	1		•	•	•		
54	8E00B2681	5		•	•	•		
55	8000B3382	1		•				
55	8000B3434	1			•			
55	8000B4855	1				•		
56	800047763	1		•	•	•		
57	62N015682	1		•	•	•		
58	800096747	1		•	•	•		
59	80A0A5147	1		•	•	•		
60	8A0023120	1		•	•	•		
61	8B0023109	1		•	•	•		
62	8A0031106	2				•		
63	8000B5278	2				•		
64	800023106	2				•		

**G01**

2



ASSIEME ALBERO MOTORE

ENGINE CRANKCASE ASSEMBLY • ENSEMBLE VILEBREQUIN
BAUGRUPPE KURBELWELLE • CONJUNTO CIGÜEÑAL

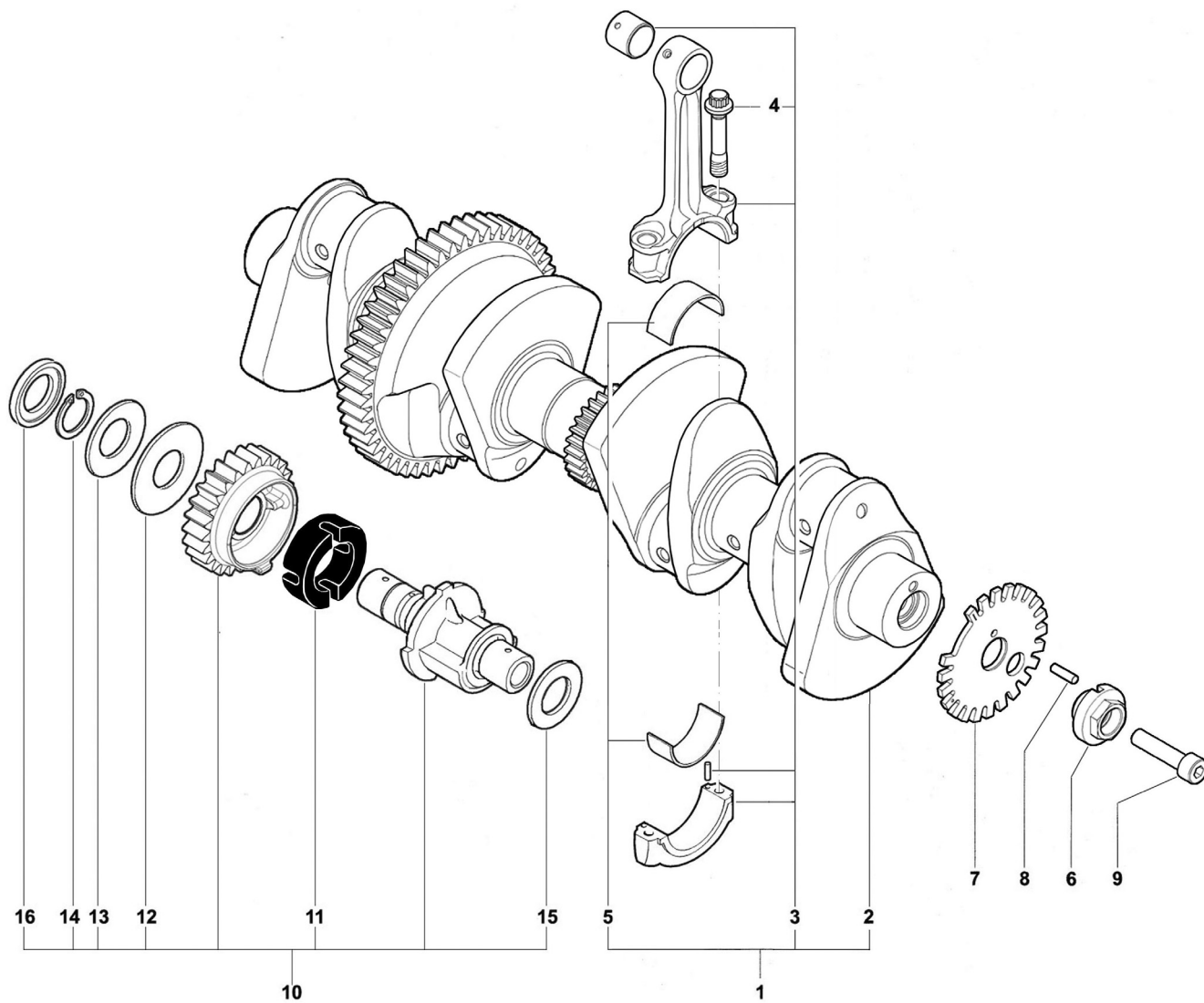

ASSIEME ALBERO MOTORE

 ENGINE CRANKCASE ASSEMBLY • ENSEMBLE VILEBREQUIN
 BAUGRUPPE KURBELWELLE • CONJUNTO CIGÜEÑAL



N.	Code	Q.ty	Note	Brutale 990 R	Brutale 1090 RR	Brutale	► I FRAME I ►	► I ENGINE I ►
1	8000B2556	1		•	•	•		
2	8000B2557	1		•	•	•		
3	8000A3026	1		•	•	•		
4	8000A5235	2		•	•	•		
5	8000B4327	8	①	•	•	•		
5	8A00B4327	8	②	•	•	•		
5	8B00B4327	8	③	•	•	•		
6	800086727	1		•	•	•		
7	800086726	1		•	•	•		
8	800019971	1		•	•	•		
9	60ND02558	1		•	•	•		
10	8000B2036	1		•	•	•		
11	8000B3398	1		•	•	•		
12	8000B2055	1		•	•	•		
13	8000B2056	1		•	•	•		
14	66N021208	1		•	•	•		
15	8F0032069	1		•	•	•		
16	8000B2563	1		•	•	•		

- ① Semicuscinetto rosso • Red half bearing • Demi-coussinet rouge • Halblager rot • Semicojinete rojo
 ② Semicuscinetto blu • Blue half bearing • Demi-coussinet bleu • Halblager blau • Semicojinete azul
 ③ Semicuscinetto giallo • Yellow half bearing • Demi-coussinet jaune • Halblager gelb • Semicojinete amarillo

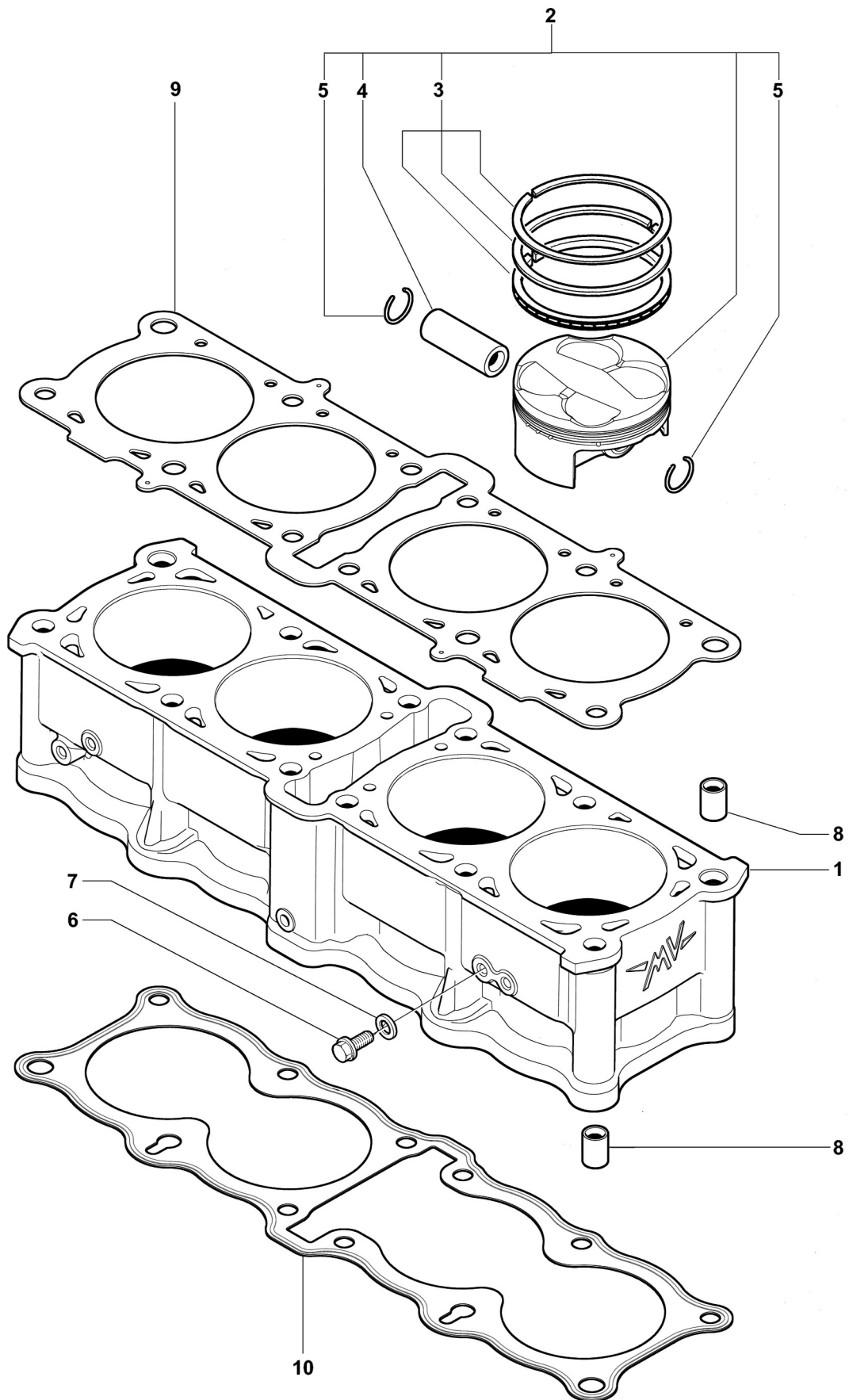

ASSIEME CILINDRI E PISTONI

CYLINDERS AND PISTONS ASSEMBLY • ENSEMBLE CYLINDRES ET PISTONS
BAUGRUPPE ZYLINDER UND KOLBEN • CONJUNTO CILINDROS Y PISTONES



ASSIEME CILINDRI E PISTONI

 CYLINDERS AND PISTONS ASSEMBLY • ENSEMBLE CYLINDRES ET PISTONS
 BAUGRUPPE ZYLINDER UND KOLBEN • CONJUNTO CILINDROS Y PISTONES

N.	Code	Q.ty	Note	Brutale 990 R	Brutale 1090 RR	Brutale	► I FRAME I ►	► I ENGINE I ►
1	80A0B3403	1		•				
1	80A0B2551	1			•			
1	80A0B4763	1				•		
2	8000B4864	4		•				
2	8000B4140	4			•			
2	8000B4847	4				•		
3	8000B4865	4		•				
3	8000B4141	4			•			
3	8000B4849	4				•		
4	8000A0606	4		•	•			
4	8000B4853	4				•		
5	8000A2714	8		•	•			
5	8000B4854	8				•		
6	800081536	2		•	•	•		
7	800064988	2		•	•	•		
8	800081535	4		•	•	•		
9	8000A5200	1	≠ 0.40	•				
9	8000A9370	1	≠ 0.40		•			
9	8000B4773	1	≠ 0.40			•		
9	8A00A5200	1	≠ 0.55	•				
9	8A00A9370	1	≠ 0.55		•			
9	8A00B4773	1	≠ 0.55			•		
9	8B00A5200	1	≠ 0.70	•				
9	8B00A9370	1	≠ 0.70		•			
9	8B00B4773	1	≠ 0.70			•		
10	8000A9371	1		•	•	•		



ASSIEME TESTATA

CYLINDER HEAD ASSEMBLY • ENSEMBLE CULASSE
BAUGRUPPE ZYLINDERKOPF • CONJUNTO CULATA

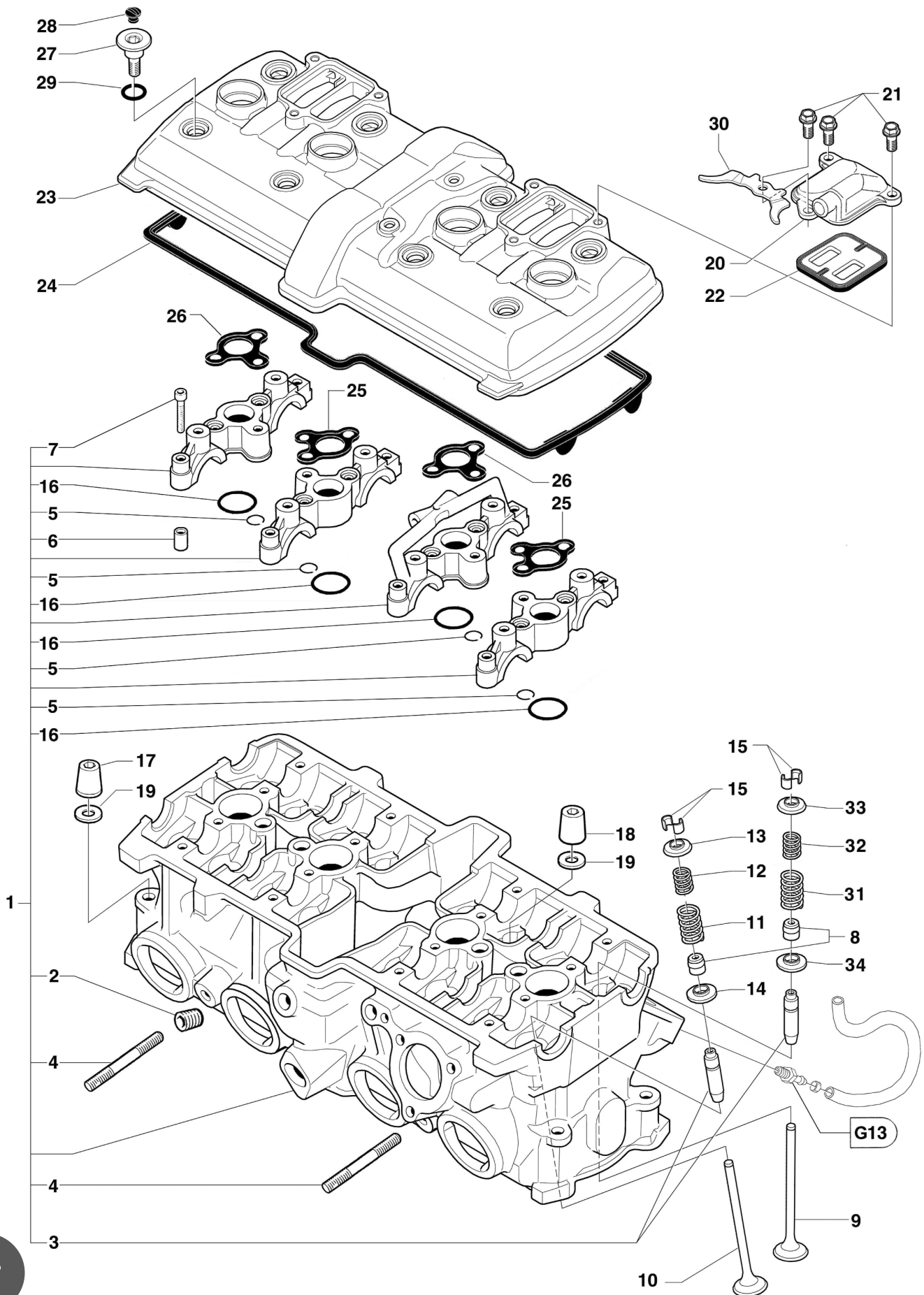

ASSIEME TESTATA

 CYLINDER HEAD ASSEMBLY • ENSEMBLE CULASSE
 BAUGRUPPE ZYLINDERKOPF • CONJUNTO CULATA

N.	Code	Q.ty	Note	Brutale 990 R	Brutale 1090 RR	Brutale	► I FRAME I ►	► I ENGINE I ►
1	8000B3268	1		•				
1	8000B3415	1			•			
1	80D0B4845	1				•		
2	800069769	7		•	•	•		
3	8A0081228	16	①	•	•	•		
3	8B0081228	16	②	•	•	•		
4	8000B2768	2		•	•	•		
5	800023108	4		•	•	•		
6	800051549	8		•	•	•		
7	800085071	16		•	•	•		
8	800065814	16		•	•	•		
9	80A0A1356	8		•	•	•		
10	80A097919	8		•	•	•		
11	800098670	16		•	•	•		
12	800098671	16		•	•	•		
13	8000A3732	16		•	•	•		
14	8000A3733	16		•	•	•		
15	800092433	32		•	•	•		
16	800087752	4		•	•	•		
17	800081547	10		•	•	•		
18	8000A8182	2		•	•	•		
19	800069156	12		•	•	•		
20	80C0B3946	2		•		•		
20	80D0B3946	2			•			
21	8C00B2681	6		•	•	•		
22	8000A2270	2		•	•	•		
23	8000B3272	1		•		•		
23	8B00B3272	1			•			
24	8000B4056	1		•	•	•		
25	8000A1938	2		•	•	•		
26	8000A1939	2		•	•	•		
27	8000B2759	8		•	•	•		
28	8000A8989	8		•	•	•		
29	800023113	8		•	•	•		
30	8000A8326	2		•	•			
30	8000B3458	2				•		

① Maggiorata 0.025 mm • Oversized 0.025 mm • Surdimensionnée 0.025 mm • Übermaß 0.025 mm • Extra grande 0.025 mm
 ② Maggiorata 0.05 mm • Oversized 0.05 mm • Surdimensionnée 0.05 mm • Übermaß 0.05 mm • Extra grande 0.05 mm



DISTRIBUZIONE
TIMING SYSTEM • DISTRIBUTION
VENTILSTEUERUNG • DISTRIBUCIÓN

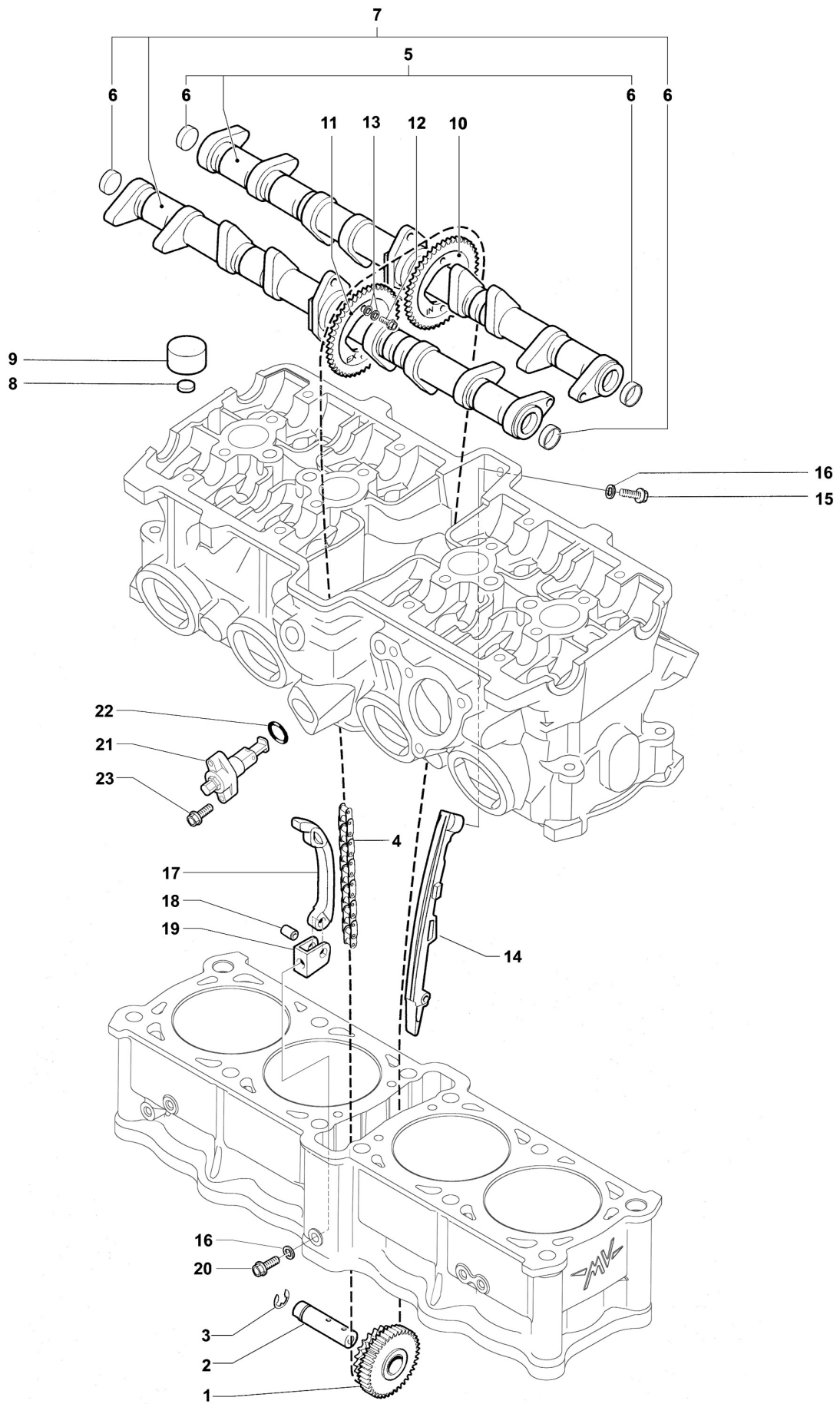



N.	Code	Q.ty	Note	Brutale 990 R	Brutale 1090 RR	Brutale	► I FRAME I ►	► I ENGINE I ►
1	800089445	1		•	•	•		
2	800081261	1		•	•	•		
3	66N021313	1		•	•	•		
4	8A00A0120	1	①	•	•	•		
4	8A0096598	1	②	•	•	•		
5	8D00B5022	1		•	•	•		
6	8C0057196	4		•	•	•		
7	8000B5024	1		•	•	•		
8	800084182	16	≠ 1.60	•	•	•		
8	8A0084182	16	≠ 1.65	•	•	•		
8	8B0084182	16	≠ 1.70	•	•	•		
8	8C0084182	16	≠ 1.75	•	•	•		
8	8D0084182	16	≠ 1.80	•	•	•		
8	8E0084182	16	≠ 1.85	•	•	•		
8	8F0084182	16	≠ 1.90	•	•	•		
8	8G0084182	16	≠ 1.95	•	•	•		
8	8H0084182	16	≠ 2.00	•	•	•		
8	8J0084182	16	≠ 2.05	•	•	•		
8	8K0084182	16	≠ 2.10	•	•	•		
8	8L0084182	16	≠ 2.15	•	•	•		
8	8M0084182	16	≠ 2.20	•	•	•		
8	8N0084182	16	≠ 2.25	•	•	•		
8	8P0084182	16	≠ 2.30	•	•	•		
8	8R0084182	16	≠ 2.35	•	•	•		
8	8S0084182	16	≠ 2.40	•	•	•		
8	8T0084182	16	≠ 2.45	•	•	•		
8	8U0084182	16	≠ 2.50	•	•	•		
8	8V0084182	16	≠ 2.55	•	•	•		
8	8W0084182	16	≠ 2.60	•	•	•		
9	8000A3478	16		•	•	•		
10	8000B1198	1		•	•	•		
11	8000A7379	1		•	•	•		
12	8C0085071	4		•	•	•		
13	8000A3486	4		•	•	•		
14	800081553	1		•	•	•		
15	8E00B2681	1		•	•	•		
16	800064988	2		•	•	•		
17	800086735	1		•	•	•		
18	800087784	1		•	•	•		
19	800087785	1		•	•	•		
20	8D00B2681	1		•	•	•		
21	800089446	1		•	•	•		
22	800018422	1		•	•	•		
23	8G00B2681	2		•	•	•		

- ① Catena di distribuzione chiusa - Timing chain closed - Chaine de distribution fermée - Ventilsteuerkette geschlossen - Cadena de distribución cerrada
- ② Catena di distribuzione aperta - Timing chain open - Chaine de distribution ouverte - Ventilsteuerkette offen - Cadena de distribución abierta



LUBRIFICAZIONE
LUBRICATION SYSTEM • GRAISSAGE
SCHMIERSYSTEM • LUBRIFICACIÓN

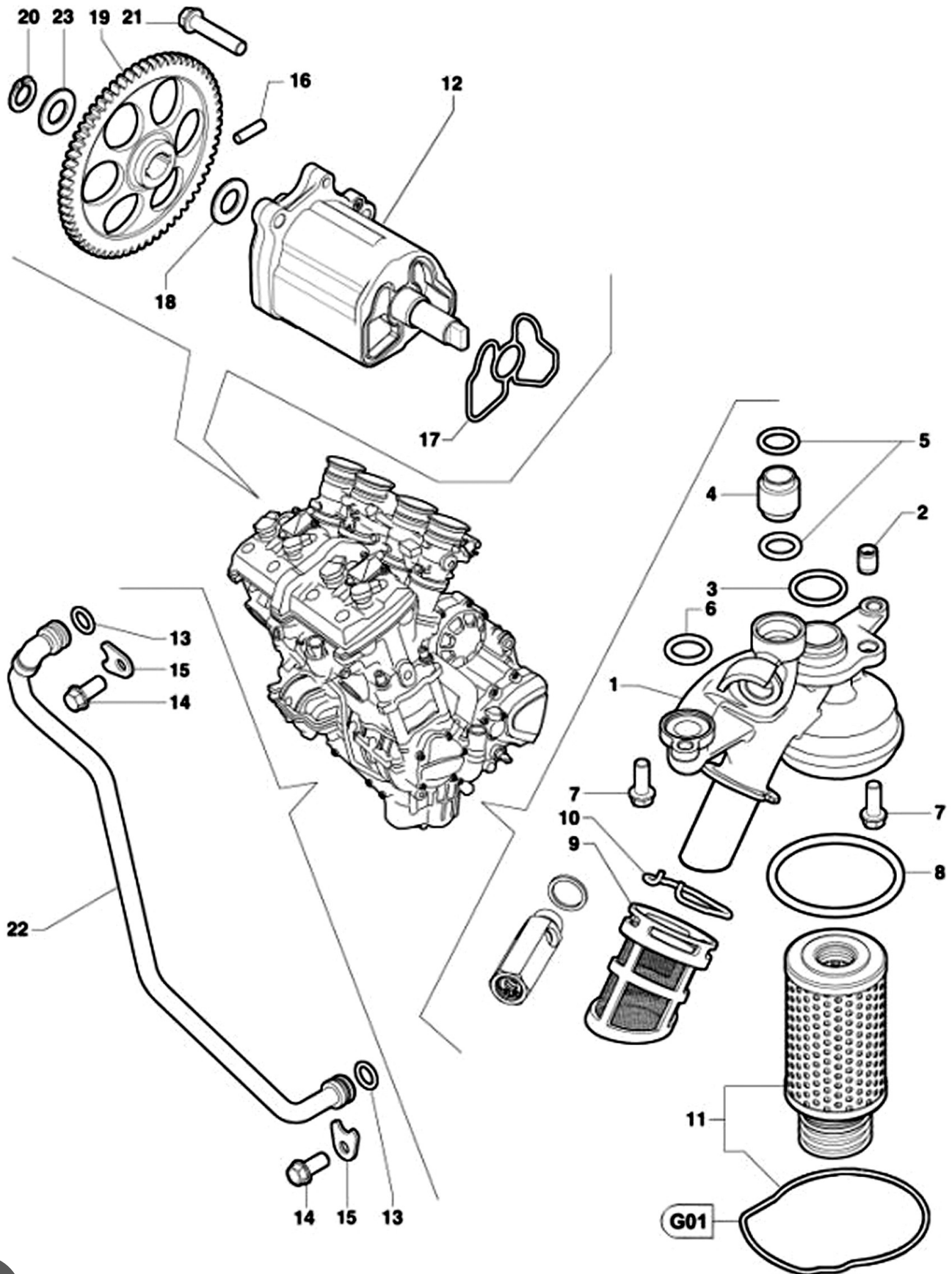

LUBRIFICAZIONELUBRICATION SYSTEM • GRAISSAGE
SCHMIERSYSTEM • LUBRIFICACIÓN

N.	Code	Q.ty	Note	Brutale 990 R	Brutale 1090 RR	Brutale	► I FRAME I ►	► I ENGINE I ►
1	8000B3433	1		•	•	•		
2	800051549	1		•	•	•		
3	8A0034323	1		•	•	•		
4	8000B3448	1		•	•	•		
5	8A0023116	2		•	•	•		
6	8A00A0819	1		•	•	•		
7	8D00B2681	2		•	•	•		
8	8000B3449	1		•	•	•		
9	8000B3450	1		•	•	•		
10	8000B3451	1		•	•	•		
11	8000B5342	1		•	•	•		
12	8000B2073	1		•	•	•		
13	8A0023108	2		•	•	•		
14	8C00B2681	2		•	•	•		
15	800095505	2		•	•	•		
16	800019971	1		•	•	•		
17	8000B2512	1		•	•	•		
18	8A00B2815	1		•	•	•		
19	8000B2031	1		•	•	•		
20	66N021202	1		•	•	•		
21	8G00B2681	3		•	•	•		
22	8000B2817	1		•	•	•		
23	8B00B2815	1		•	•	•		



POMPA ACQUA
WATER PUMP • POMPE À EAU
WASSERPUMPE • BOMBA AGUA

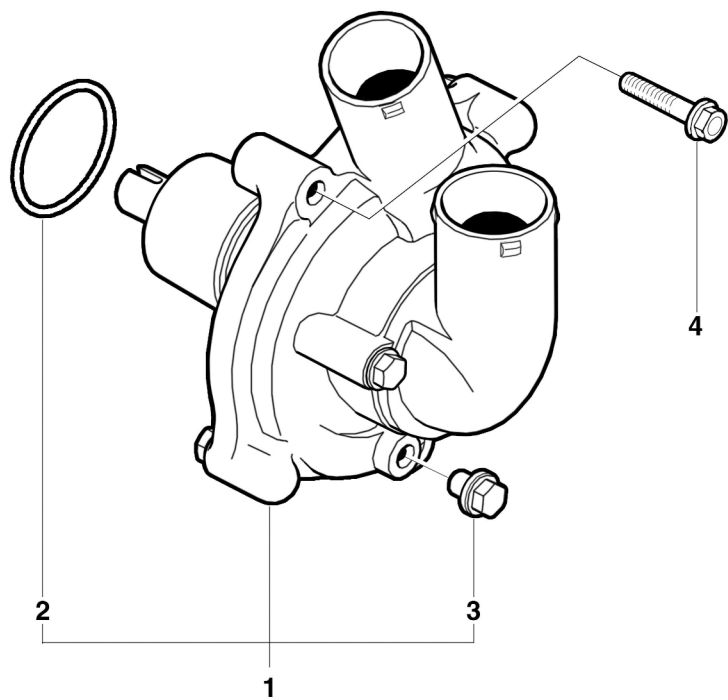
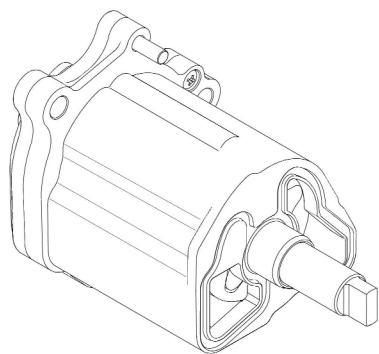

POMPA ACQUAWATER PUMP • POMPE À EAU
WASSERPUMPE • BOMBA AGUA

N.	Code	Q.ty	Note	Brutale 990 R	Brutale 1090 RR	Brutale	► I FRAME I ►	► I ENGINE I ►
1	8000B3315	1		•	•	•		
2	8000B2574	1		•	•	•		
3	8000B4308	1		•	•	•		
4	8J00B2681	2		•	•	•		



IMPIANTO DI RAFFREDDAMENTO
COOLING SYSTEM • CIRCUIT DE REFRROIDISSEMENT
KÜHLSYSTEM • INSTALACIÓN DE REFRIGERACIÓN

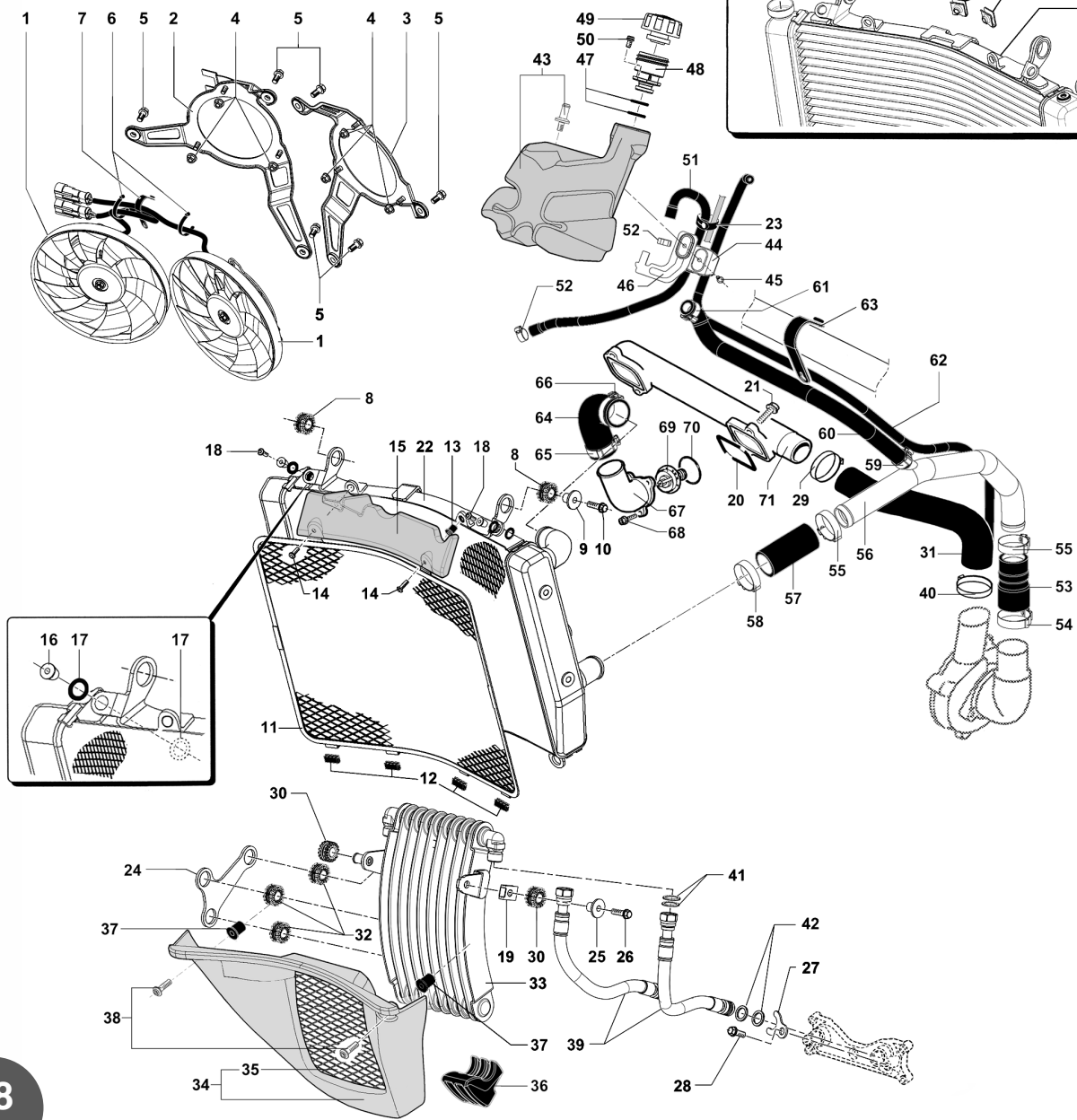
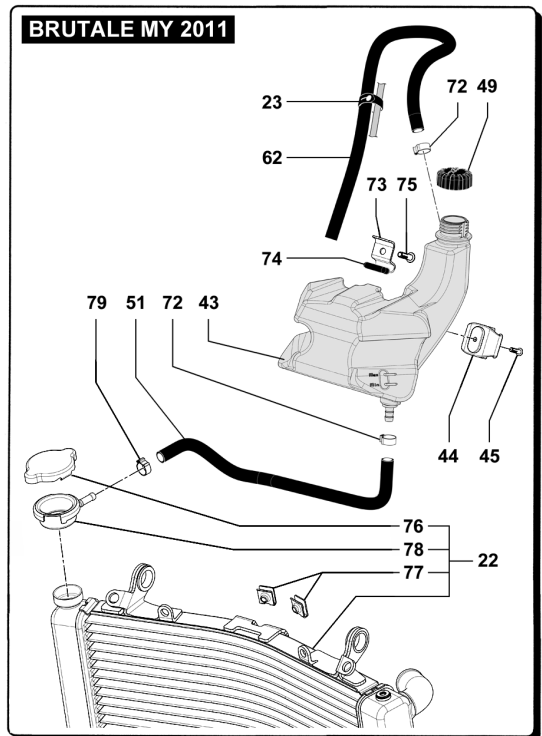

IMPIANTO DI RAFFREDDAMENTO

COOLING SYSTEM • CIRCUIT DE REFROIDISSEMENT
KÜHLSYSTEM • INSTALACIÓN DE REFRIGERACIÓN



N.	Code	Q.ty	Note	Brutale 990 R	Brutale 1090 RR	Brutale	► I FRAME I ►	► I ENGINE I ►
1	8000A7505	2		•	•	•		
2	80A0A8944	1		•	•	•		
3	80A0A8945	1		•	•	•		
4	8000B2707	6		•	•	•		
5	8C00B2681	6		•	•	•		
6	800056783	2		•	•	•		
7	800092668	1		•	•	•		
8	8000B1539	2		•	•	•		
9	8E0062652	1		•	•	•		
10	8G00B2681	1		•	•	•		
11	800098716	1		•	•	•		
12	800099249	4		•	•	•		
13	800091022	2		•	•	•		
14	8A0090901	2		•	•	•		
15	8000A1409	1		•	•	•		
16	800091022	2		•	•	•		
17	800099278	4		•	•	•		
18	8A0090901	2		•	•	•		
19	800046893	1		•	•	•		
20	800017679	2		•	•	•		
21	8E00B2681	4		•	•	•		
22	8000B3096	1		•	•	•		
22	8000B4358	1				•		
23	800053724	1		•	•	•		
24	8000B3087	1		•	•	•		
25	800062652	1		•	•	•		
26	8G00B2681	1		•	•	•		
27	8000B3093	2		•	•	•		
28	8A00B2681	2		•	•	•		
29	8V0092249	1		•	•	•		
30	800062651	2		•	•	•		
31	800081280	1		•	•	•		
32	800062651	3		•	•	•		
33	8000B3091	1		•	•	•		
34	8A0099432	1		•	•	•		
35	800099293	1		•	•	•		
36	800099322	1		•	•	•		
37	800048245	2		•	•	•		
38	8B00B2672	2		•	•	•		
39	8000B3088	2		•	•	•		
40	8C0092249	1		•	•	•		
41	8000B3201	4		•	•	•		
42	8B0023109	4		•	•	•		
43	8A0098943	1		•	•	•		
43	8000B4518	1				•		
44	800097884	1		•	•	•		
45	8A00B2778	1		•	•	•		
45	60ND02461	1				•		
46	80A099453	1		•	•	•		
47	800090945	2		•	•	•		
48	8A0090944	1		•	•	•		
49	8AA091707	1		•	•	•		
49	8000B4910	1				•		
50	8B00B2687	2		•	•	•		
51	800090245	1		•	•	•		
51	8L0066179	1				•		





IMPIANTO DI RAFFREDDAMENTO
COOLING SYSTEM • CIRCUIT DE REFRROIDISSEMENT
KÜHLSYSTEM • INSTALACIÓN DE REFRIGERACIÓN

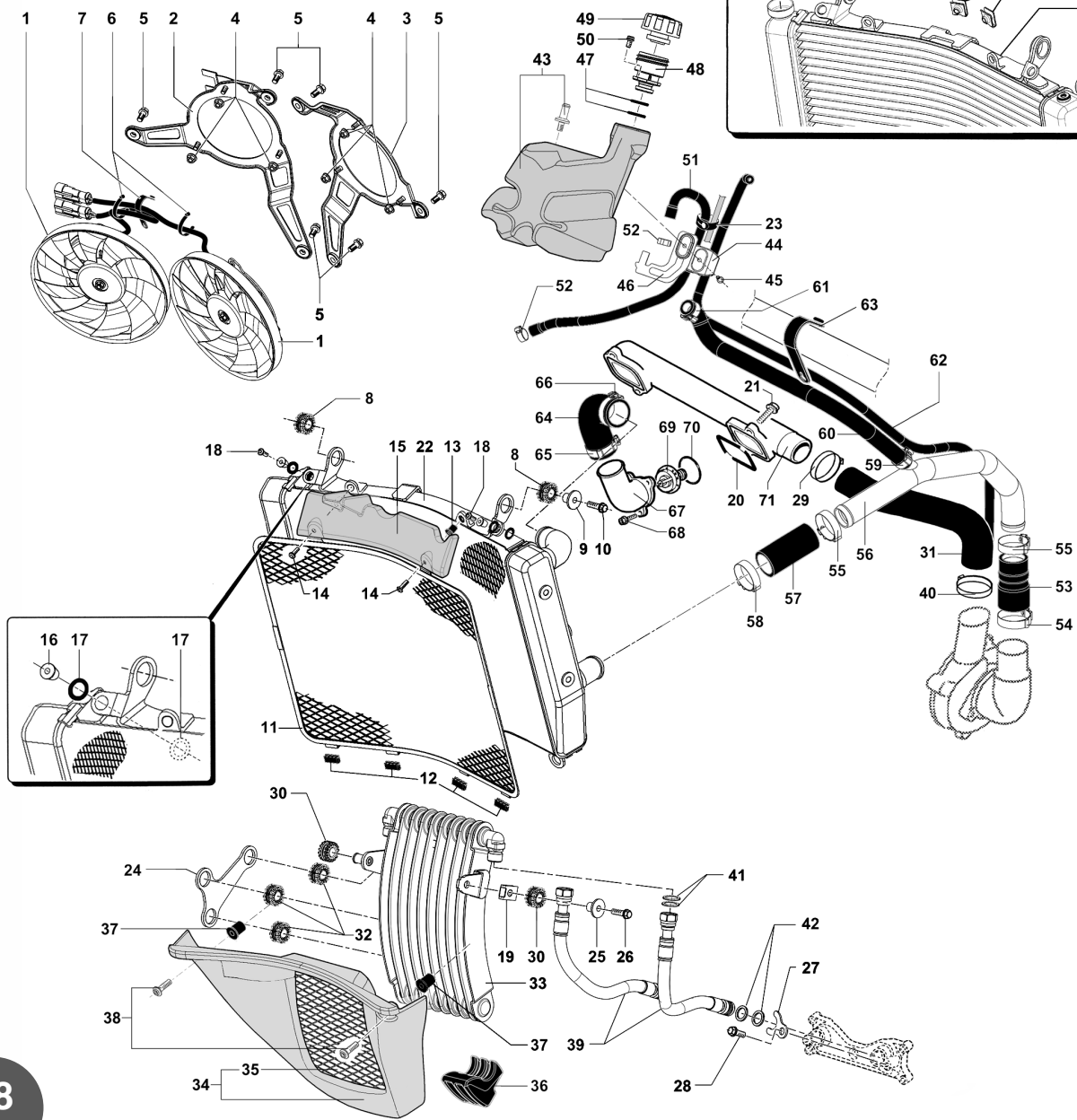
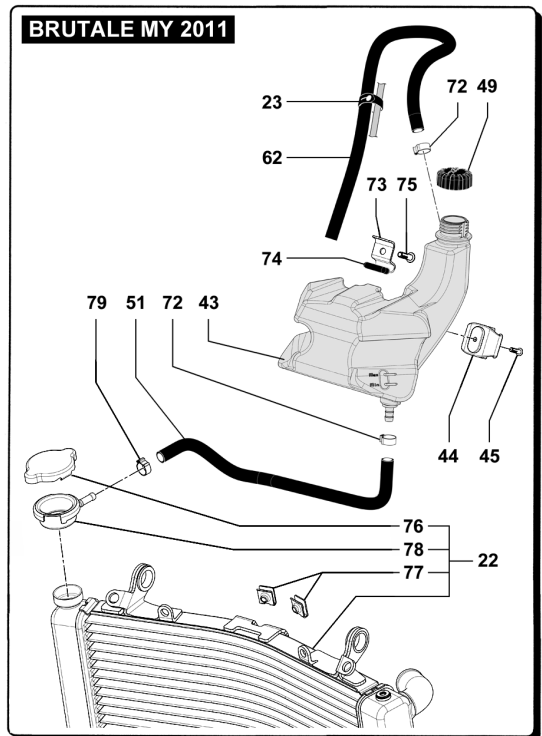

IMPIANTO DI RAFFREDDAMENTO

COOLING SYSTEM • CIRCUIT DE REFROIDISSEMENT
KÜHLSYSTEM • INSTALACIÓN DE REFRIGERACIÓN



N.	Code	Q.ty	Note	Brutale 990 R	Brutale 1090 RR	Brutale	► I FRAME I ►	► I ENGINE I ►
52	800092256	2		•	•			
53	800090244	1		•	•	•		
54	8U0092249	1		•	•	•		
55	8G0092249	2		•	•	•		
56	80A099250	1		•	•			
56	80A0B4517	1				•		
57	8A0097109	1		•	•	•		
58	8V0092249	1		•	•	•		
59	8E0092249	1		•	•			
60	8A0094186	1		•	•			
61	8Q0092249	1		•	•			
62	8M0066179	1		•	•			
62	8V0066179	1				•		
63	800092248	1		•	•	•		
64	8000A7507	1		•	•	•		
65	8C0092249	1		•	•	•		
66	8G0092249	1		•	•	•		
67	80B0B1623	1		•	•	•		
68	8E00B2681	3		•	•	•		
69	800081283	1		•	•	•		
70	800069413	1		•	•	•		
71	80A0B3498	1		•	•	•		
72	800092256	2				•		
73	8000B4430	1				•		
74	800099426	1				•		
75	8A00B2681	1				•		
76	8000B3638	1				•		
77	8000B4712	4				•		
78	8000B4713	1				•		
79	800064586	1				•		





ASSIEME FRIZIONE (BRUTALE 990 R / BRUTALE MY 2011)

CLUTCH ASSEMBLY (B5 990 R / BRUTALE MY 2011) • ENSEMBLE EMBRAYAGE (B5 990 R / BRUTALE MY 2011)
BAUGRUPPE KUPPLUNG (B5 990 R / BRUTALE MY 2011) • CONJUNTO EMBRAGUE (B5 990 R / BRUTALE MY 2011)

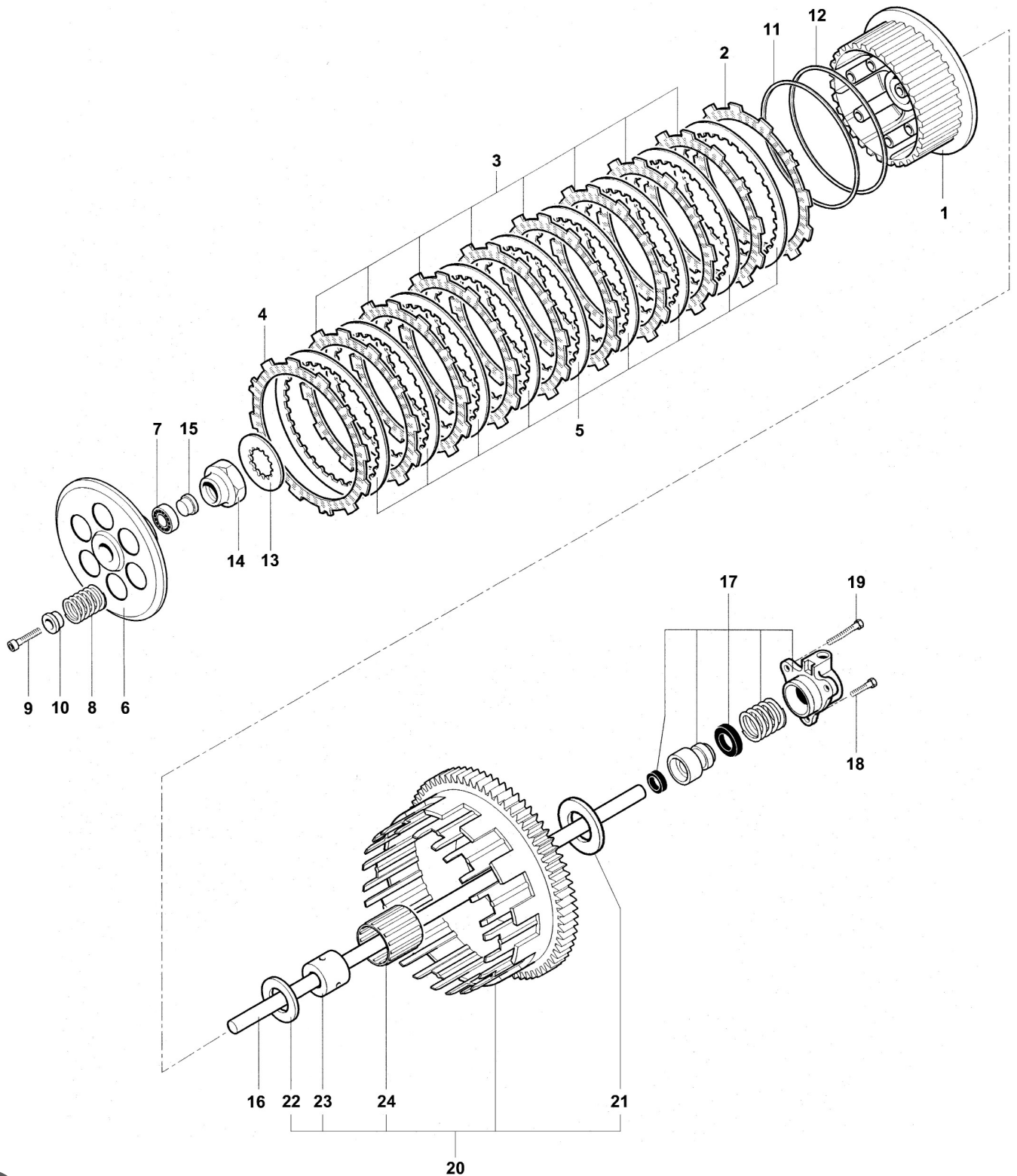

ASSIEME FRIZIONE (BRUTALE 990 R / BRUTALE MY 2011)

CLUTCH ASSEMBLY (B5 990 R / BRUTALE MY 2011) • ENSEMBLE EMBRAYAGE (B5 990 R / BRUTALE MY 2011)

BAUGRUPPE KUPPLUNG (B5 990 R / BRUTALE MY 2011) • CONJUNTO EMBRAGUE (B5 990 R / BRUTALE MY 2011)



N.	Code	Q.ty	Note	Brutale 990 R	Brutale 1090 RR	Brutale	► I FRAME I ►	► I ENGINE I ►
1	8000A6914	1		•		•		
2	8000A6915	1		•		•		
3	8000A6916	8		•		•		
4	8000A6917	1		•		•		
5	8000A6918	9		•		•		
6	8000A6919	1		•		•		
7	8000A2565	1		•		•		
8	8000A6921	6		•		•		
9	60N302515	6		•		•		
10	8000A4492	6		•		•		
11	8000A6922	1		•		•		
12	8000A6923	1		•		•		
13	8000B3312	1		•		•		
14	8000B2716	1		•		•		
15	8000A2566	1		•		•		
16	800088342	1		•		•		
17	80D081478	1		•		•		
18	8E00B2681	2		•		•		
19	8M00B2681	1		•		•		
20	8000B3278	1		•		•		
21	8000A2554	1		•		•		
22	8000A2555	1		•		•		
23	8000A2556	1		•		•		
24	8000A2553	1		•		•		



ASSIEME CAMBIO

CHANGE GEAR ASSEMBLY • ENSEMBLE BOÎTE DE VITESSE
BAUGRUPPE GETRIEBE • CONJUNTO CAMBIO

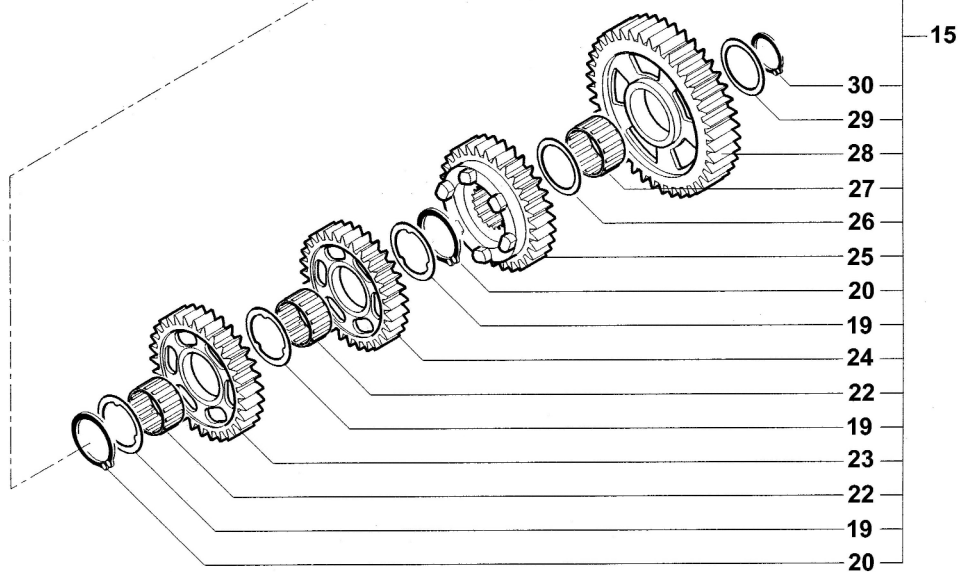
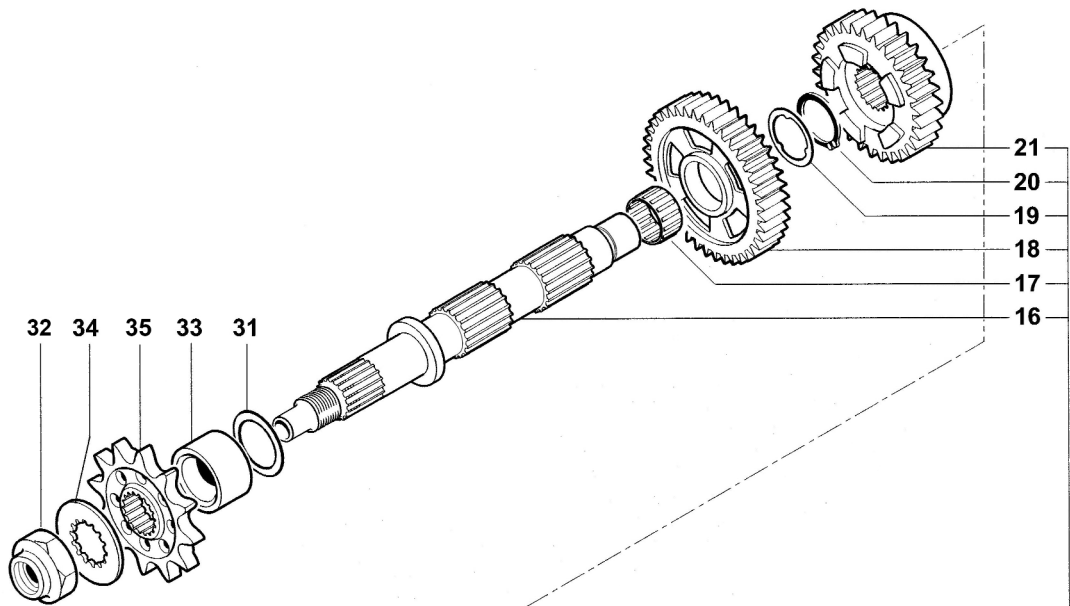
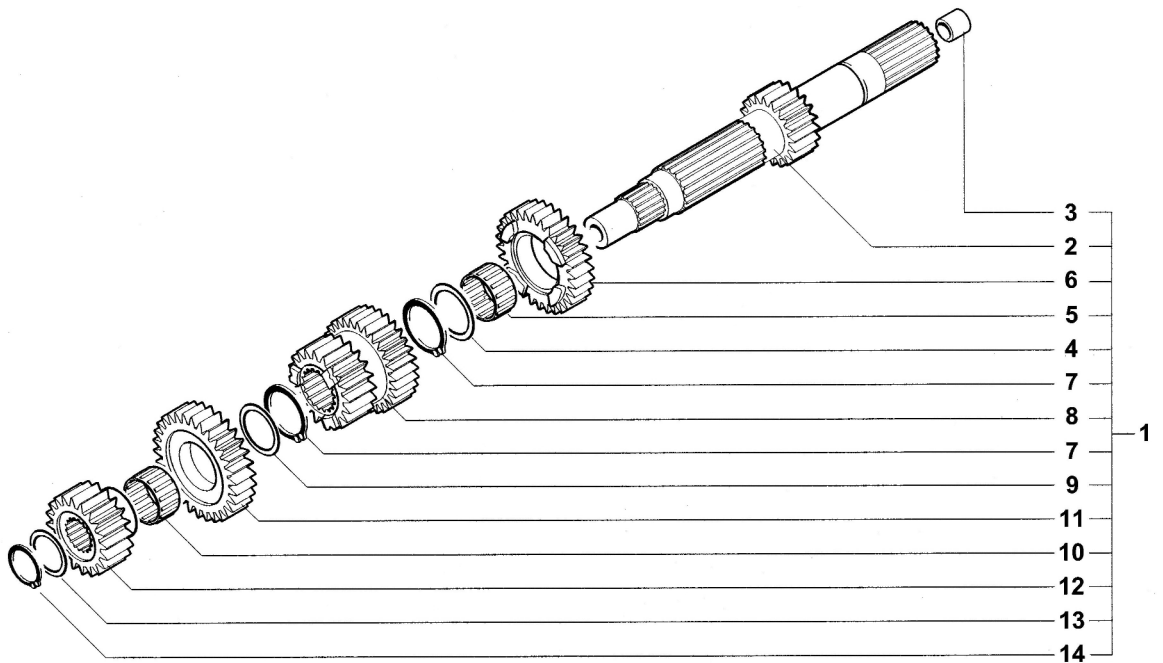

ASSIEME CAMBIO

 CHANGE GEAR ASSEMBLY • ENSEMBLE BOÎTE DE VITESSE
 BAUGRUPPE GETRIEBE • CONJUNTO CAMBIO

N.	Code	Q.ty	Note	Brutale 990 R	Brutale 1090 RR	Brutale	► I FRAME I ►	► I ENGINE I ►
1	8000A2643	1		•	•	•		
2	8000A2644	1		•	•	•		
3	800086699	1		•	•	•		
4	8000A0973	1		•	•	•		
5	8000A0370	1		•	•	•		
6	8000A2630	1		•	•	•		
7	8000A0975	2		•	•	•		
8	8000A2631	1		•	•	•		
9	8000A0973	1		•	•	•		
10	8000A0370	1		•	•	•		
11	8000A1956	1		•	•	•		
12	8000A2645	1		•	•	•		
13	8D0081569	1		•	•	•		
14	66N221210	1		•	•	•		
15	8000B3310	1		•	•	•		
16	8000B2083	1		•	•	•		
17	8000A0370	1		•	•	•		
18	8000A2650	1		•	•	•		
19	8000A4196	4		•	•	•		
20	8000A0990	3		•	•	•		
21	8000A1957	1		•	•	•		
22	8000A0370	2		•	•	•		
23	8000A2637	1		•	•	•		
24	8000A2638	1		•	•	•		
25	8000B0020	1		•	•	•		
26	8000A0987	1		•	•	•		
27	8000A0370	1		•	•	•		
28	8000A2640	1		•	•	•		
29	8000A4780	1		•	•	•		
30	66N221210	1		•	•	•		
31	8000A1234	1	≠ 1.4 mm	•	•	•		
31	8A00A1234	1	≠ 1.5 mm	•	•	•		
31	8B00A1234	1	≠ 1.6 mm	•	•	•		
32	8000B2716	1		•	•	•		
33	8A00A2319	1		•	•	•		
34	8000B3312	1		•	•	•		
35	8000A1949	1	Z = 15	•	•	•		



SELETTORE CAMBIO

GEAR SELECTOR • SÉLECTEUR DE VITESSES
GANGSCHALTER • SELECTOR CAMBIO

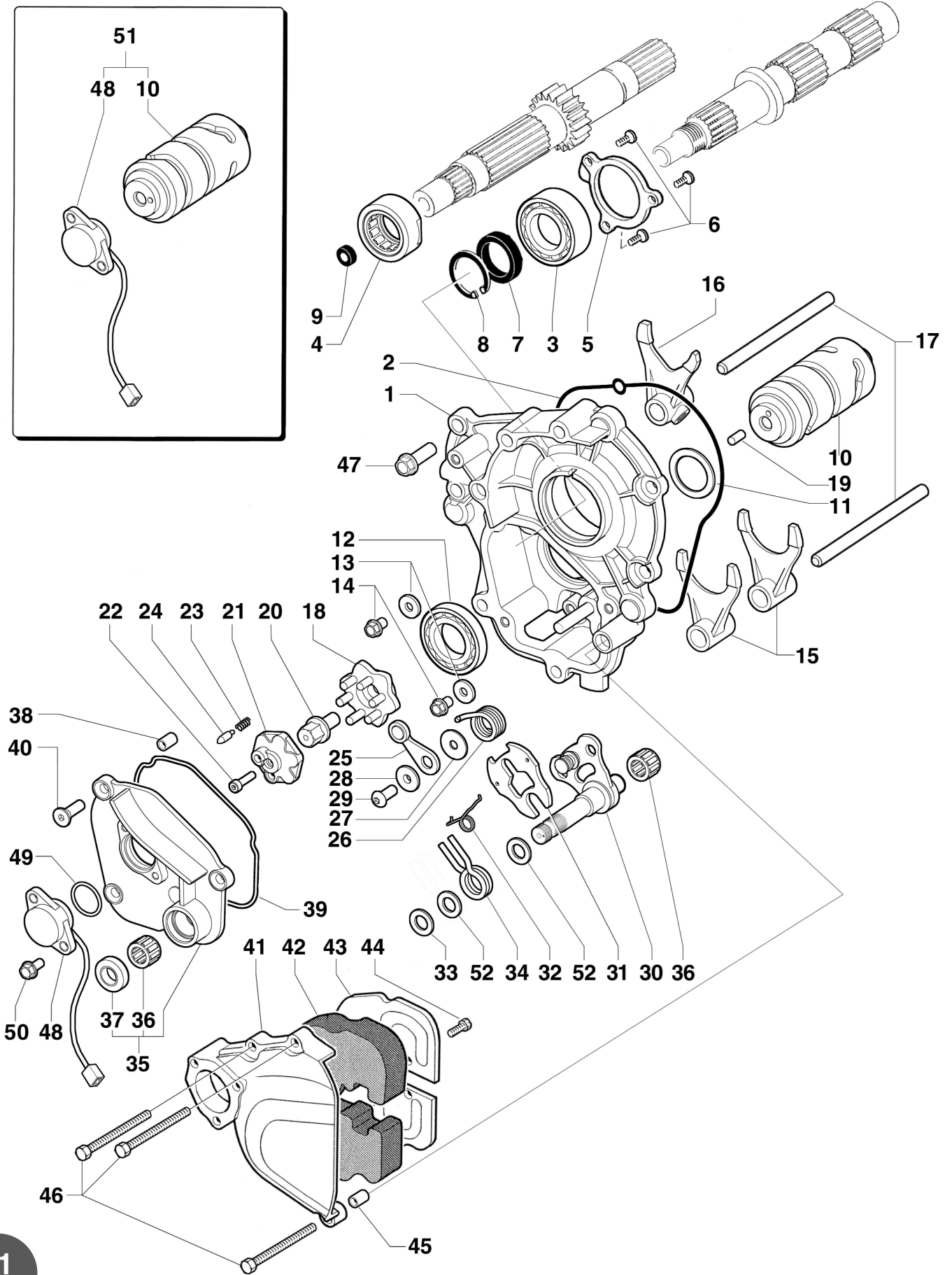

SELETTORE CAMBIO

 GEAR SELECTOR • SÉLECTEUR DE VITESSES
 GANGSCHALTER • SELECTOR CAMBIO



N.	Code	Q.ty	Note	Brutale 990 R	Brutale 1090 RR	Brutale	► I FRAME I ►	► I ENGINE I ►
1	8000B2841	1		•	•	•		
2	800086117	1		•	•	•		
3	8000A2318	1		•	•	•		
4	8000A1086	1		•	•	•		
5	800086114	1		•	•	•		
6	8B00B2695	3		•	•	•		
7	800089410	1		•	•	•		
8	800091603	1		•	•	•		
9	800064296	1		•	•	•		
10	8000B3313	1		•	•	•		
10	8000B2086	1	❶	•	•	•		
11	8A0036022	1	≠ 0.2 mm	•	•	•		
11	8B0036022	1	≠ 0.3 mm	•	•	•		
11	8C0036022	1	≠ 0.4 mm	•	•	•		
12	8A0021774	1		•	•	•		
13	8000A0901	2		•	•	•		
14	8C00B2681	2		•	•	•		
15	800081583	2		•	•	•		
16	8000A2537	1		•	•	•		
17	800081585	2		•	•	•		
18	8000B4065	1		•	•	•		
19	800038520	1		•	•	•		
20	8000B2844	1		•	•	•		
21	8000B4116	1		•	•	•		
22	60ND02466	1		•	•	•		
23	8000B4220	1		•	•	•		
24	800042676	1		•	•	•		
25	800085495	1		•	•	•		
26	800092490	1		•	•	•		
27	800086107	1		•	•	•		
28	800085493	1		•	•	•		
29	8C00B2677	1		•	•	•		
30	8000B3470	1		•	•	•		
31	8000B2847	1		•	•	•		
32	8000B2848	1		•	•	•		
33	8G0004551	1		•	•	•		
34	8000B5544	1		•	•	•		
35	8000B2850	1		•	•	•		
36	800051191	1		•	•	•		
36	800051191	1		•	•	•		
37	8A0028855	1		•	•	•		
38	800051549	1		•	•	•		
39	800089406	1		•	•	•		
40	8E00B2695	3		•	•	•		
41	80A0B4196	1		•	•	•		
42	800088347	1		•	•	•		
43	8000B3522	1		•	•	•		
44	8A00B2680	3		•	•	•		
45	800086131	2		•	•	•		
46	8A00B2683	6		•	•	•		
47	8C00B2683	3		•	•	•		
48	8000B2607	1		•	•	•		
48	8000B4902	1	❶	•	•	•		
49	8A0042700	1		•	•	•		
50	8C00B2680	2		•	•	•		
51	8000B4920	1	❶	•	•	•		
52	8H0004553	2		•	•	•		

❶ Kit albero comando cambio rovesciato - Upside-down gear control shaft kit - Kit barillet de boite de vitesse à l'envers - Oberseite unten Getriebe Steuerwelle Bausatz - Kit eje accionamento comando cambio al revés.

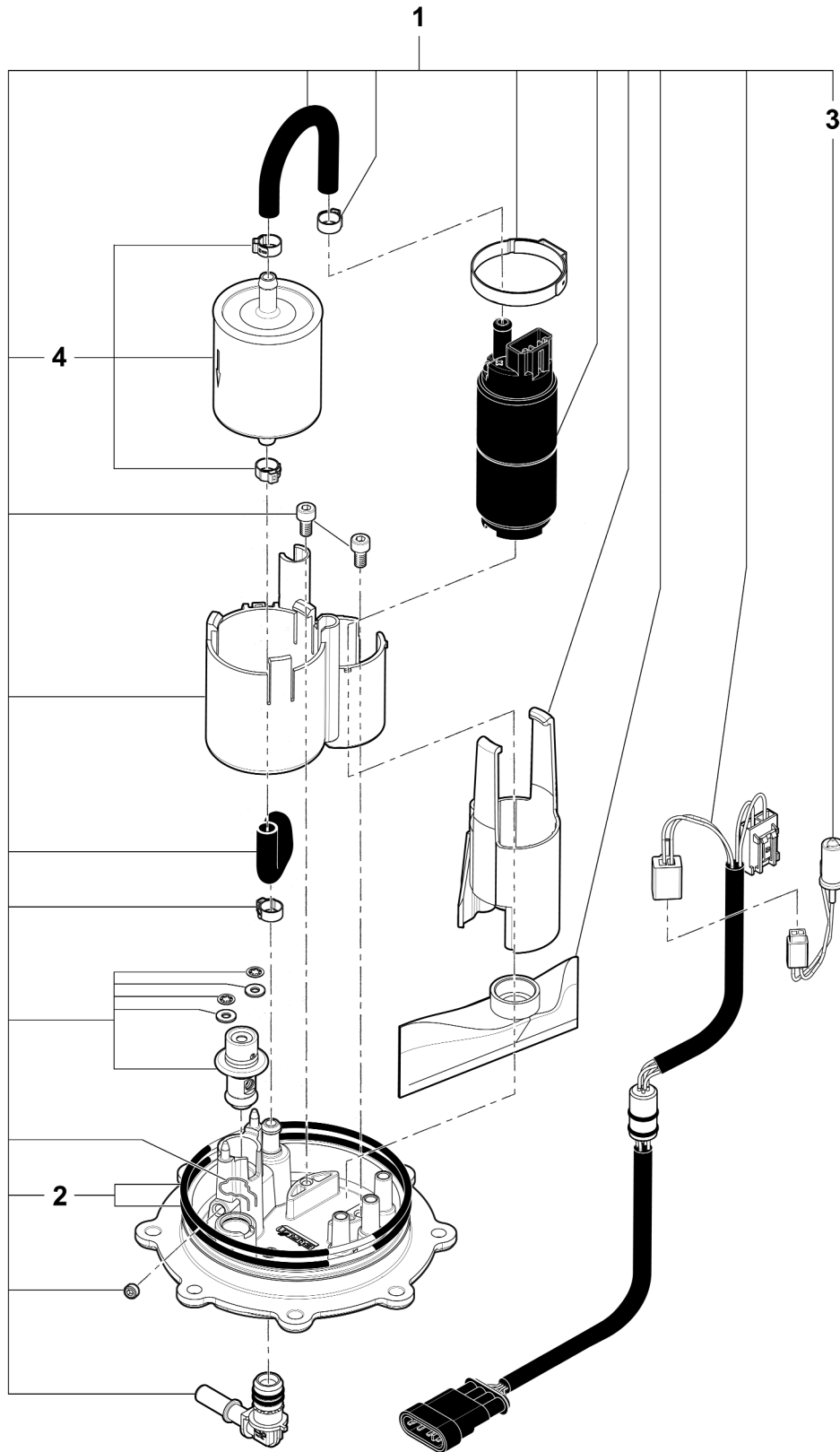

GRUPPO POMPA BENZINA

FUEL PUMP ASSEMBLY • GROUPE POMPE D'ALIMENTATION
BAUGRUPPE BENZINPUMPE • GRUPO BOMBA GASOLINA



GRUPPO POMPA BENZINAFUEL PUMP ASSEMBLY • GROUPE POMPE D'ALIMENTATION
BAUGRUPPE BENZINPUMPE • GRUPO BOMBA GASOLINA

N.	Code	Q.ty	Note	Brutale 990 R	Brutale 1090 RR	Brutale	► I FRAME I ►	► I ENGINE I ►
1	8000B1958	1		•	•	•		
1	8A00B1958	1	USA	•	•	•		
2	8000B4276	1		•	•	•		
3	8000B4277	1		•	•	•		
4	8000B4278	1		•	•	•		



ALIMENTAZIONE MOTORE
FUEL SYSTEM • ALIMENTATION MOTEUR
MOTORVERSORGUNG • ALIMENTACIÓN MOTOR

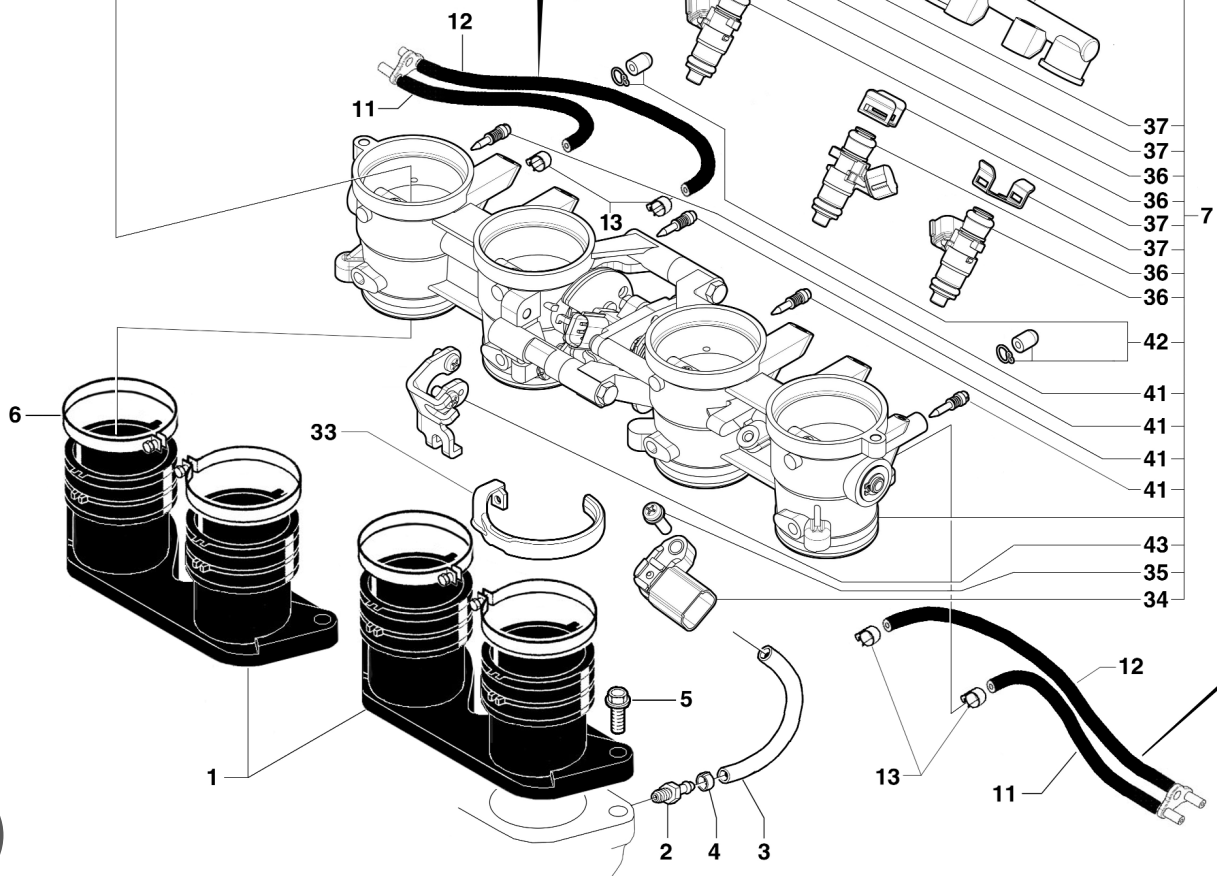
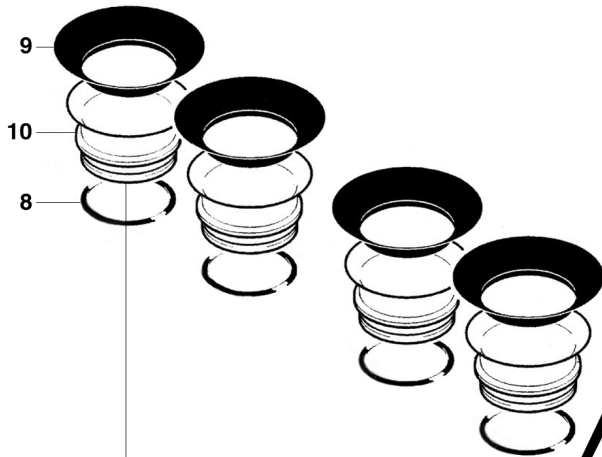
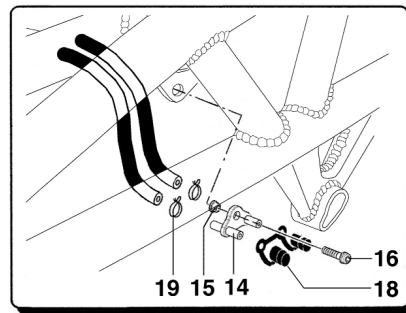
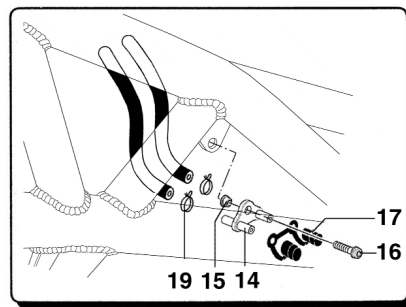
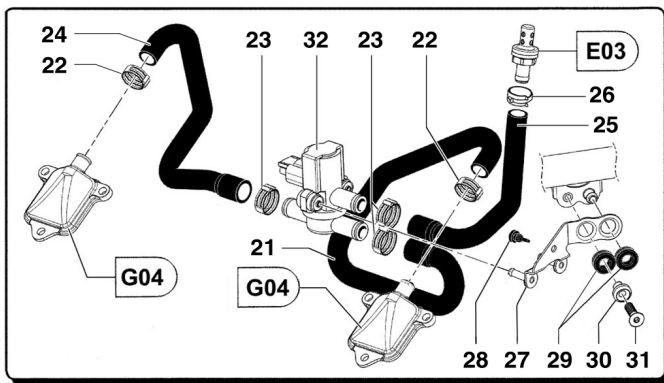



N.	Code	Q.ty	Note	Brutale 990 R	Brutale 1090 RR	Brutale	► I FRAME I ►	► I ENGINE I ►
1	8B00B3221	2		•	•	•		
2	8000B3525	1		•	•	•		
3	8G0091037	1		•	•	•		
4	800096458	1		•	•	•		
5	60ND02509	6		•	•	•		
6	800089404	4		•	•	•		
7	8000B3298	1		•	•	•		
8	800081304	4		•	•	•		
9	800090350	4		•	•	•		
10	800091595	4		•	•	•		
10	8000A5282	4	F	•	•	•		
11	8A0091037	2		•	•	•		
12	8C0091037	2		•	•	•		
13	800096458	4		•	•	•		
14	800089801	2		•	•	•		
15	8000B2798	2		•	•	•		
16	8B00B2680	2		•	•	•		
17	800089799	1	1	•	•	•		
18	800089800	1	1	•	•	•		
19	8AA091634	4		•	•	•		
20	8000B3005	1		•	•	•		
21	8000A9044	1		•	•	•		
22	8D0092256	2		•	•	•		
23	8E0092249	3		•	•	•		
26	8K0095276	1		•	•	•		
24	8000A9045	1		•	•	•		
25	8000B3445	1		•	•	•		
27	80A0A9042	1		•	•	•		
28	800095828	1		•	•	•		
29	800089293	2		•	•	•		
30	8000A4009	1		•	•	•		
31	8D00B2695	1		•	•	•		
32	8000A9043	1		•	•	•		
33	8000B4230	1		•	•	•		
34	8000B3432	1		•	•	•		
35	8E00B2680	1		•	•	•		
36	8000B4312	4		•	•	•		
37	8000B4313	4		•	•	•		
38	8000B4314	1		•	•	•		
39	8000B4320	1		•	•	•		
40	8000B4316	2		•	•	•		
41	8000B4317	1		•	•	•		
42	8000B4318	1		•	•	•		
43	8000B4319	1		•	•	•		

1 Esclusi gli USA (vedi tavola K02) - USA excluded (see table K02) - Sauf les USA (voir planche K02) - Ausschließlich USA (siehe Tafel K02) - Excluidos los USA (ver tabla K02).



AVVIAMENTO

STARTING SYSTEM • DÉMARREUR

ANLASSERSYSTEM • PUESTA EN MARCHA

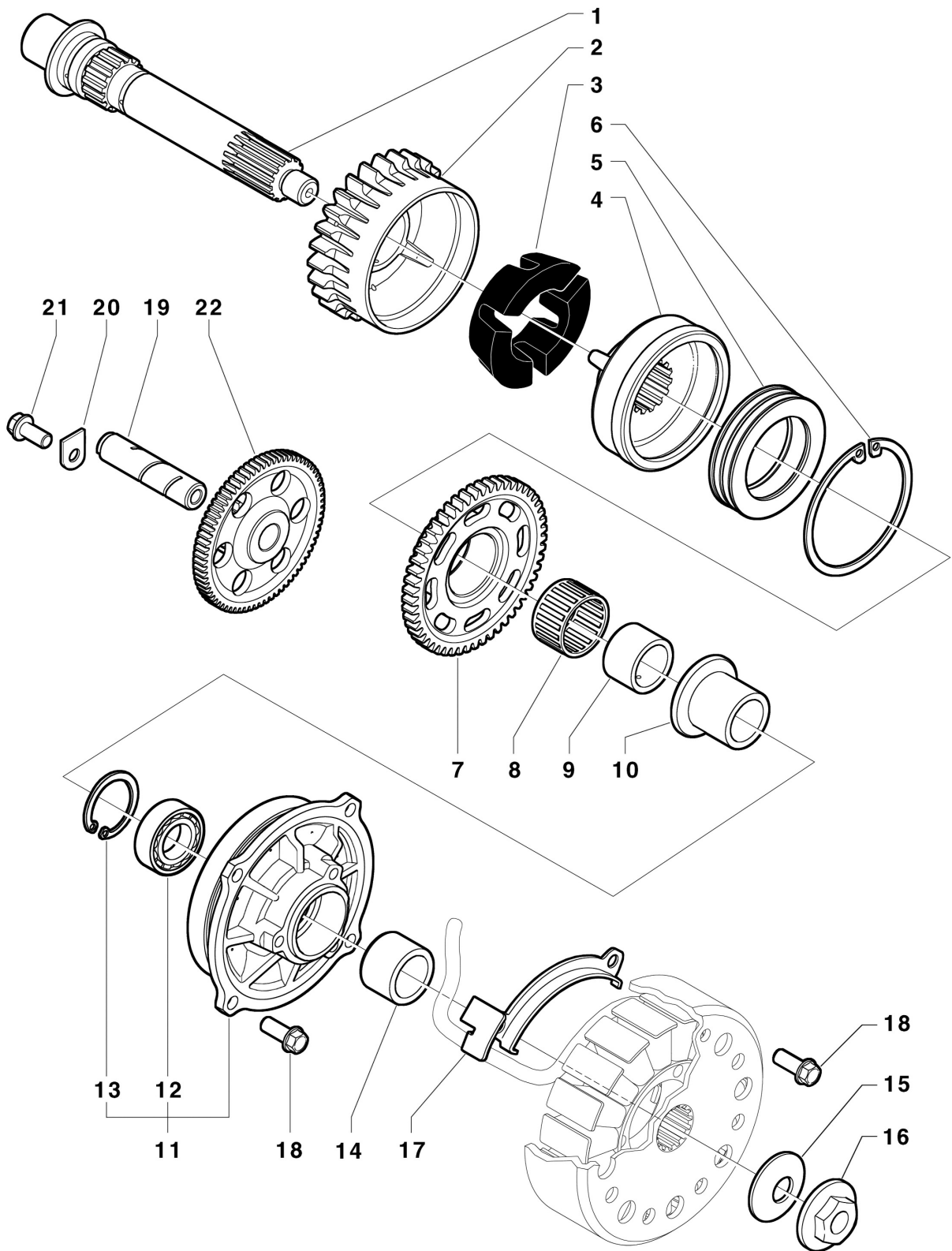

AVVIAMENTO

 STARTING SYSTEM • DÉMARREUR
 ANLASSERSYSTEM • PUESTA EN MARCHA



N.	Code	Q.ty	Note	Brutale 990 R	Brutale 1090 RR	Brutale	► I FRAME I ►	► I ENGINE I ►
1	8000B1989	1		•	•	•		
2	8000B3301	1	❶	•	•	•		
3	8000B3302	1		•	•	•		
4	8000B3303	1		•	•	•		
5	8000B3304	1		•	•	•		
6	8000B3305	1		•	•	•		
7	8000A2126	1		•	•	•		
8	8000B2038	1		•	•	•		
9	8A0065795	1		•	•	•		
10	8000B2037	1		•	•	•		
11	8000B4839	1	❷	•	•	•		
12	800017040	1		•	•	•		
13	66N021270	1		•	•	•		
14	8000B2039	1		•	•	•		
15	8000B3307	1		•	•	•		
16	8000A7390	1		•	•	•		
17	8000B3970	1		•	•	•		
18	60ND07335	4		•	•	•		
19	8000A2131	1		•	•	•		
20	8000A2139	1		•	•	•		
21	8C00B2681	1		•	•	•		
22	8000A2140	1		•	•	•		

- ❶ Ordinare con il part. N° 11 - To be ordered with part No. 11 - A commander avec la pièce N° 11 - Dieser Teil muss mit dem Teil Nr. 11 bestellt werden - Esta piéza debe ser ordenada con la piéza N° 11.
- ❷ Ordinare con il part. N° 2 - To be ordered with part No. 2 - A commander avec la pièce N° 2 - Dieser Teil muss mit dem Teil Nr. 2 bestellt werden - Esta piéza debe ser ordenada con la piéza N° 2.

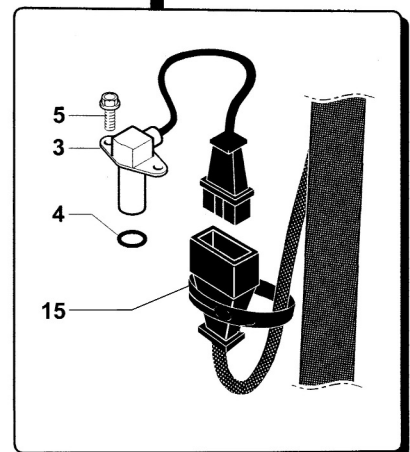
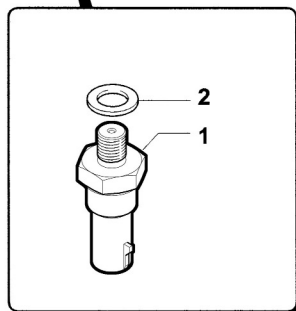
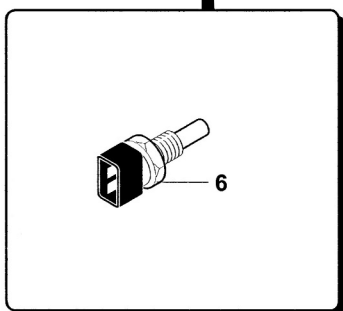
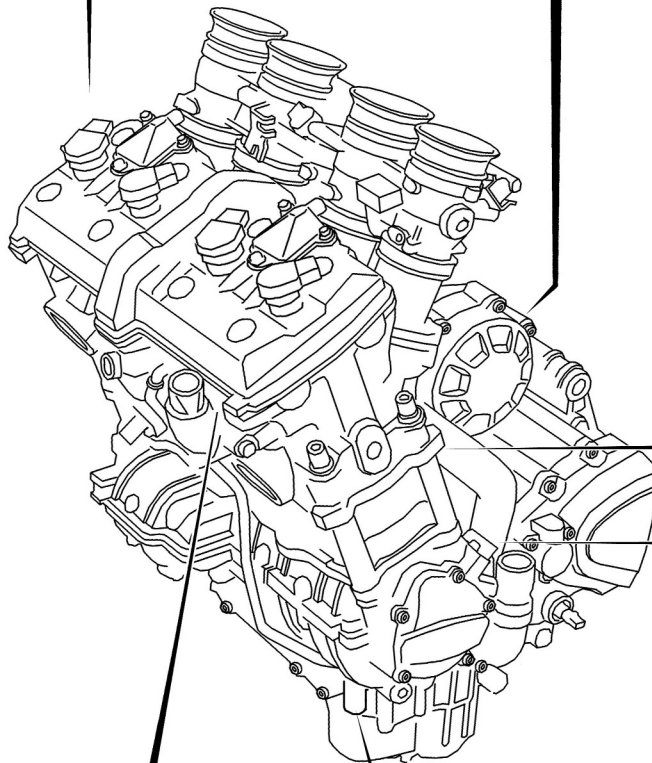
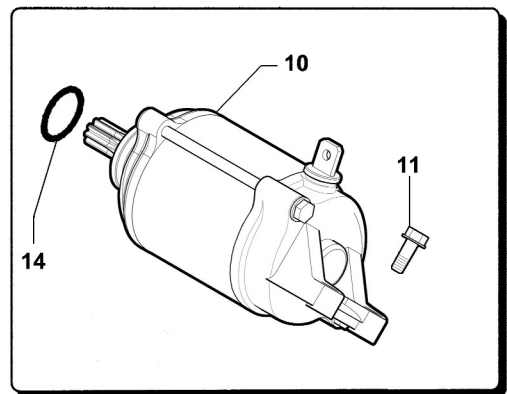
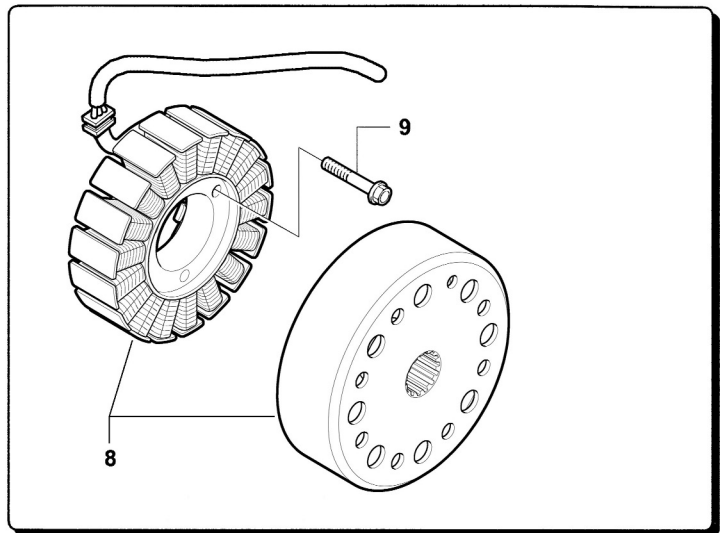
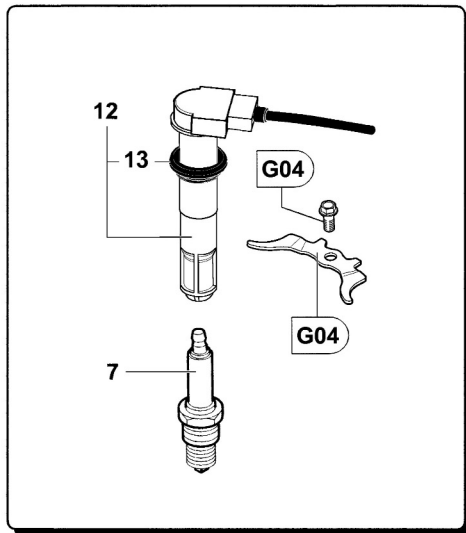

IMPIANTO ELETTRICO MOTORE

ENGINE ELECTRIC SYSTEM • INSTALLATION ÉLECTRIQUE MOTEUR
ELEKTRISCHE ANLAGE MOTOR • INSTALACIÓN ELÉCTRICA MOTOR



IMPIANTO ELETTRICO MOTOREENGINE ELECTRIC SYSTEM • INSTALLATION ÉLECTRIQUE MOTEUR
ELEKTRISCHE ANLAGE MOTOR • INSTALACIÓN ELÉCTRICA MOTOR

N.	Code	Q.ty	Note	Brutale 990 R	Brutale 1090 RR	Brutale	► I FRAME I ►	► I ENGINE I ►
1	8000A7862	1		•	•	•		
2	62N015676	1		•	•	•		
3	800090184	1		•	•	•		
4	800022551	1		•	•	•		
5	8C00B2680	2		•	•	•		
6	8000B3497	1		•	•	•		
7	800095906	4	NGK CR9 EB	•	•	•		
8	8000B4872	1		•	•	•		
9	60ND07331	3		•	•	•		
10	8000B2549	1		•	•	•		
11	8F00B2681	2		•	•	•		
12	8000A6700	4		•	•	•		
13	8000A0515	4		•	•	•		
14	800091597	1		•	•	•		
15	800092248	1		•	•	•		



IMPIANTO DI SCARICO
EXHAUST SYSTEM • ÉCHAPPEMENT
ABGASANLAGE • INSTALACIÓN DE ESCAPE

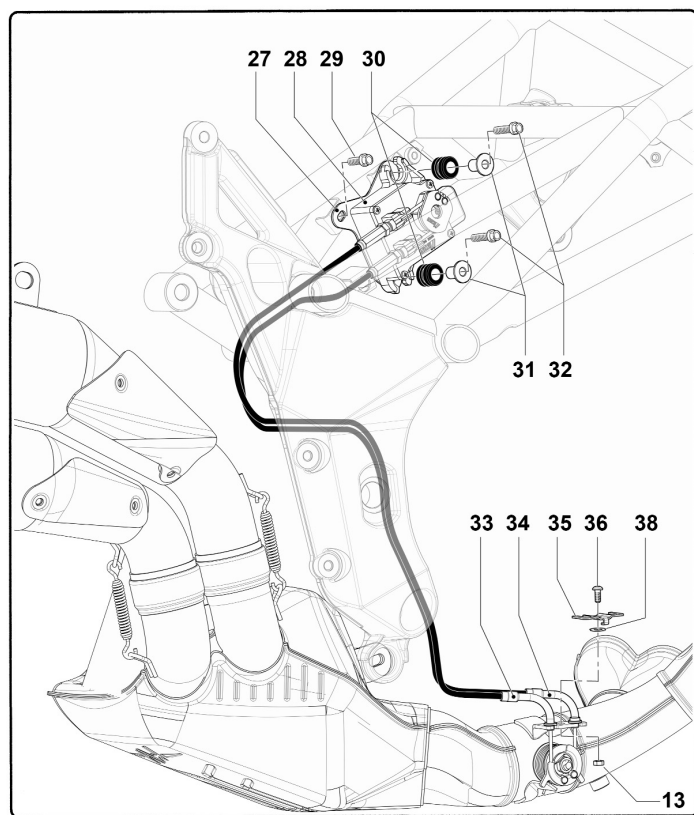
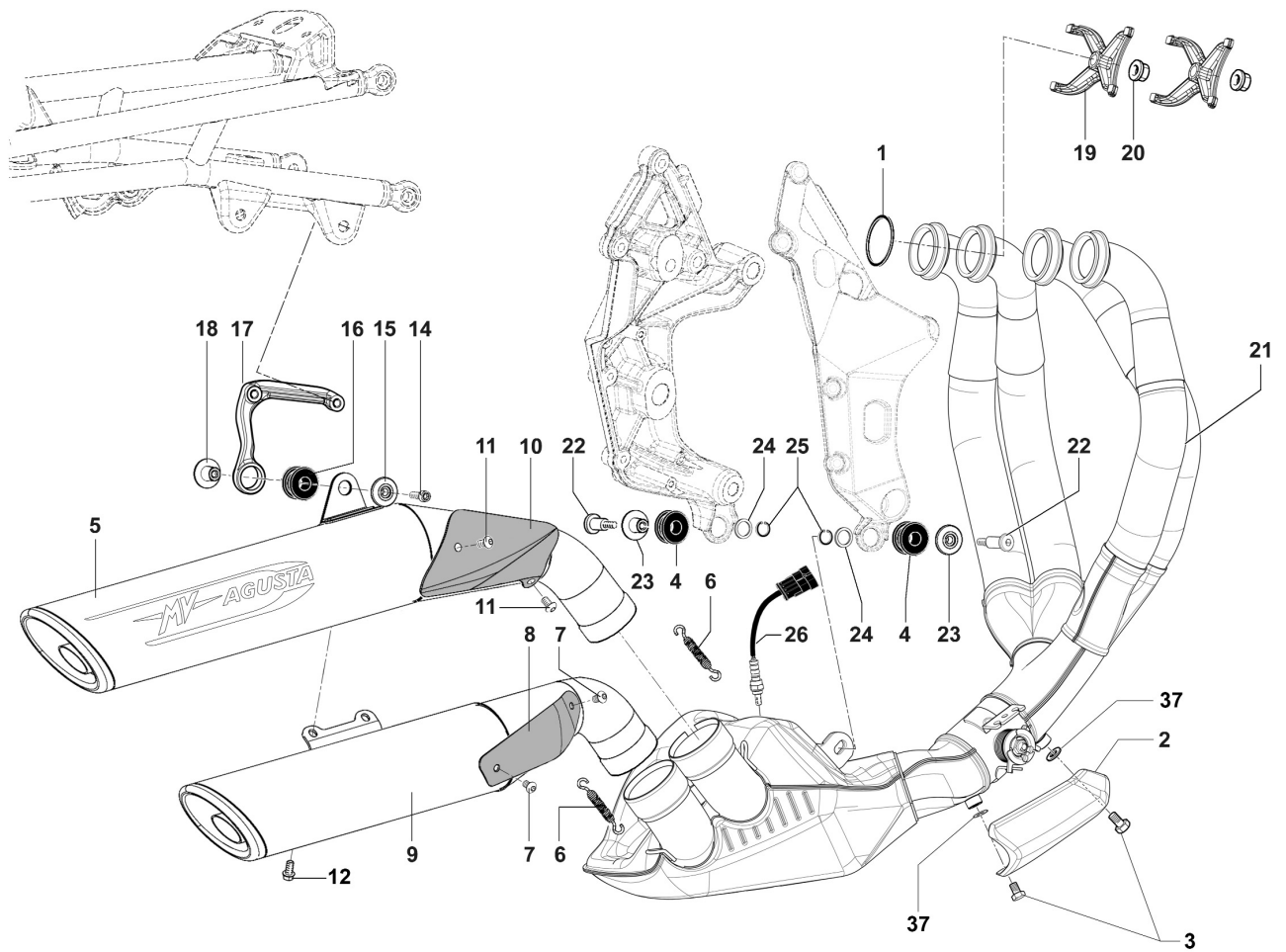

IMPIANTO DI SCARICO
 EXHAUST SYSTEM • ÉCHAPPEMENT
 ABGASANLAGE • INSTALACIÓN DE ESCAPE



N.	Code	Q.ty	Note	Brutale 990 R	Brutale 1090 RR	Brutale	► I FRAME I ►	► I ENGINE I ►
1	800099383	4		•	•	•		
2	8000B4112	1		•	•	•		
3	8A00B2681	2		•	•		► I 000640	
3	8000B2681	2		•	•		000641 ►	
3	8000B2681	2				•		
4	800089302	2		•	•	•		
5	8000B2797	1		•	•	•		
6	8000A1239	2		•	•	•		
7	8000B2677	2		•	•	•		
8	800099403	1		•	•	•		
9	8000B2796	1		•	•	•		
10	800099349	1		•	•	•		
11	8000B2677	2		•	•	•		
12	8B00B2681	2		•	•	•		
13	8000B2707	1		•	•	•		
14	8D00B2688	1		•	•	•		
15	8000A9997	1		•	•	•		
16	800089302	1		•	•	•		
17	8000B3015	1		•	•	•		
18	8A0099348	1		•	•	•		
19	800090419	2		•	•	•		
20	8000B2712	2		•	•	•		
21	8000B2650	1		•	•	•		
22	8000A9999	2		•	•	•		
23	8000A9998	2		•	•	•		
24	8000B0000	2		•	•	•		
25	66N021202	2		•	•	•		
26	8000A8968	1		•	•	•		
27	8000B4108	1		•	•	•		
28	8000B2126	1		•	•	•		
29	8000B2681	1		•	•	•		
30	8000B3673	2		•	•	•		
31	8000B3674	2		•	•	•		
32	8F00B2681	2		•	•	•		
33	8000B4114	1		•	•	•		
34	8000B4109	1		•	•	•		
35	8000B4110	1		•	•	•		
36	8B00B2680	1		•	•	•		
37	80B004898	1		•	•		► I 000640	
38	80A036137	1		•	•		► I 000698	



ASSIEME FRIZIONE (BRUTALE 1090 RR)

CLUTCH ASSEMBLY (BRUTALE 1090 RR) • ENSEMBLE EMBRAYAGE (BRUTALE 1090 RR)
BAUGRUPPE KUPPLUNG (BRUTALE 1090 RR) • CONJUNTO EMBRAGUE (BRUTALE 1090 RR)

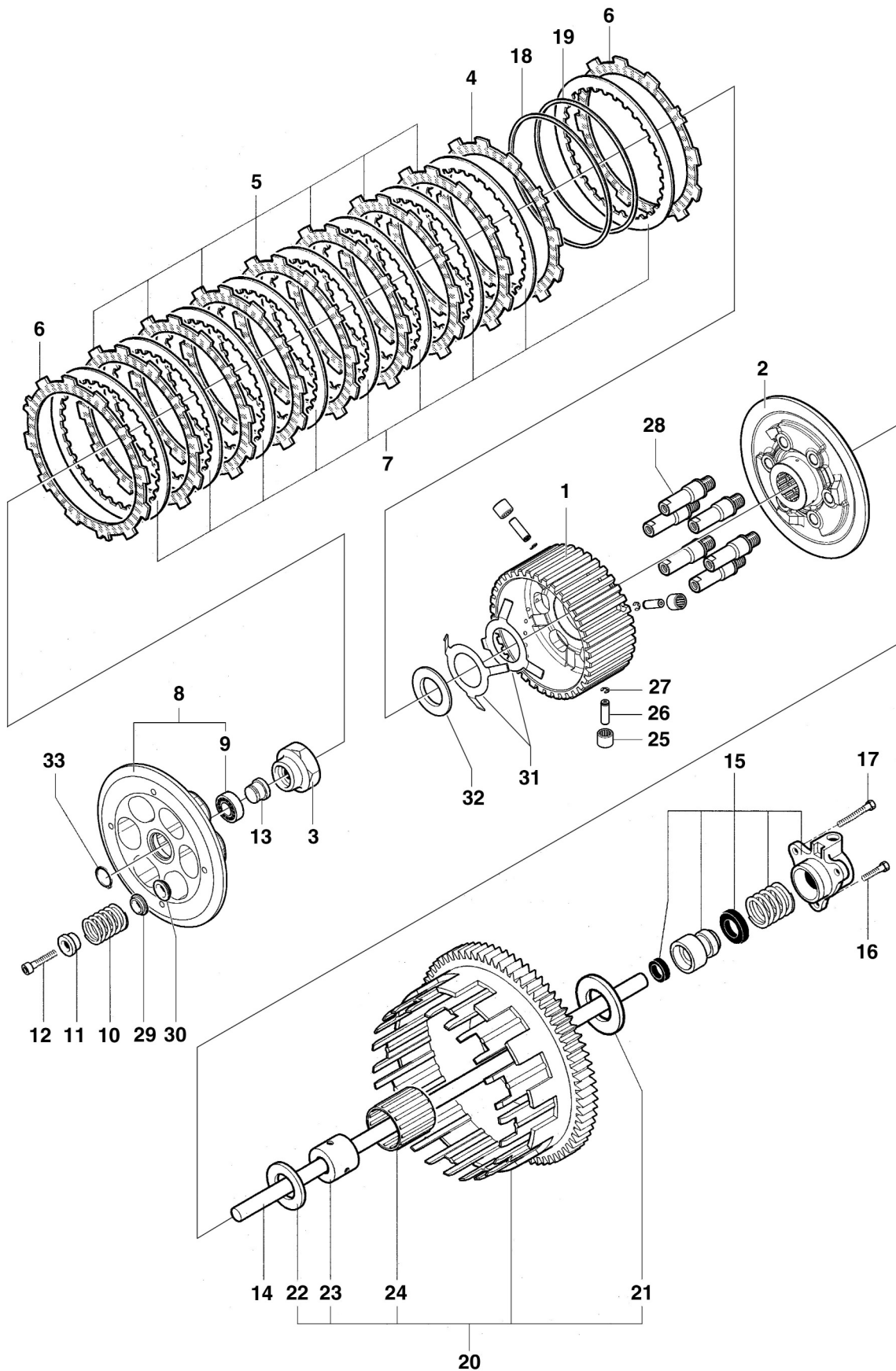

ASSIEME FRIZIONE (BRUTALE 1090 RR)

CLUTCH ASSEMBLY (BRUTALE 1090 RR) • ENSEMBLE EMBRAYAGE (BRUTALE 1090 RR)

BAUGRUPPE KUPPLUNG (BRUTALE 1090 RR) • CONJUNTO EMBRAGUE (BRUTALE 1090 RR)



N.	Code	Q.ty	Note	Brutale 990 R	Brutale 1090 RR	Brutale	► I FRAME I ►	► I ENGINE I ►
1	8000B1015	1			•			
2	8000B1014	1			•			
3	8000B2716	1			•			
4	8000A6915	1			•			
5	8000A6916	7			•			
6	8000A6917	2			•			
7	8000A6918	9			•			
8	8000B1019	1			•			
9	8000A2565	1			•			
10	8000A0730	6			•			
11	8000A4492	6			•			
12	60ND02509	6			•			
13	8000B1947	1			•			
14	800088342	1			•			
15	80D081478	1			•			
16	8E00B2681	2			•			
17	8M00B2681	1			•			
18	8000A6922	1			•			
19	8000A6923	1			•			
20	8000B3278	1			•			
21	8000A2554	1			•			
22	8000A2555	1			•			
23	8000A2556	1			•			
24	8000A2553	1			•			
25	8000B0066	3			•			
26	8000B0067	3			•			
27	66N021306	3			•			
28	8000B0064	6			•			
29	8000B0070	6			•			
30	8000B2046	6			•			
31	8000B0071	2			•			
32	8000B0072	1			•			
33	66N021202	1			•			



DOTAZIONI

OUTFIT • ÉQUIPEMENT
BORDWERKZEUG • EQUIPAMIENTO

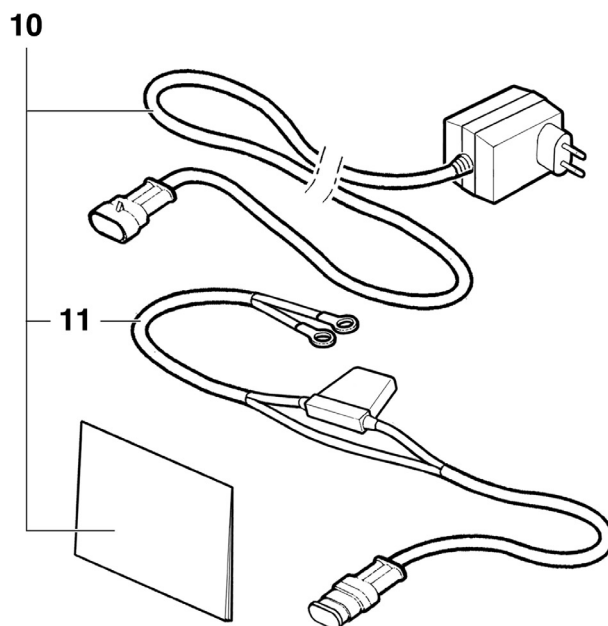
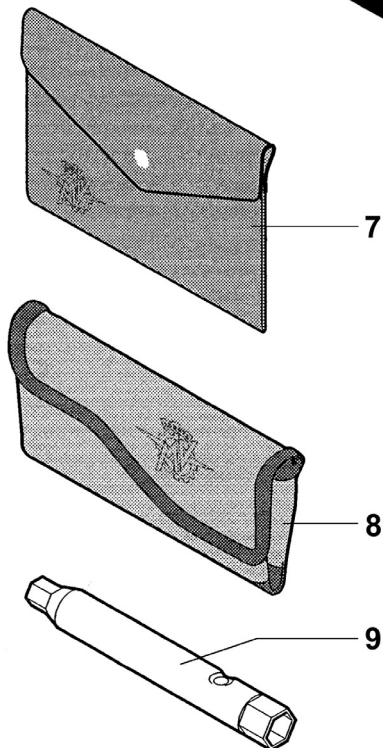
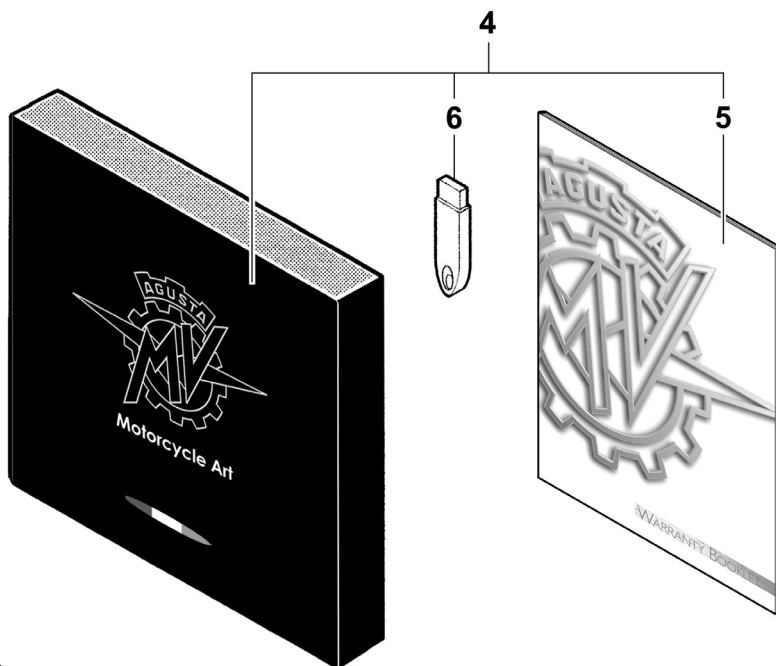
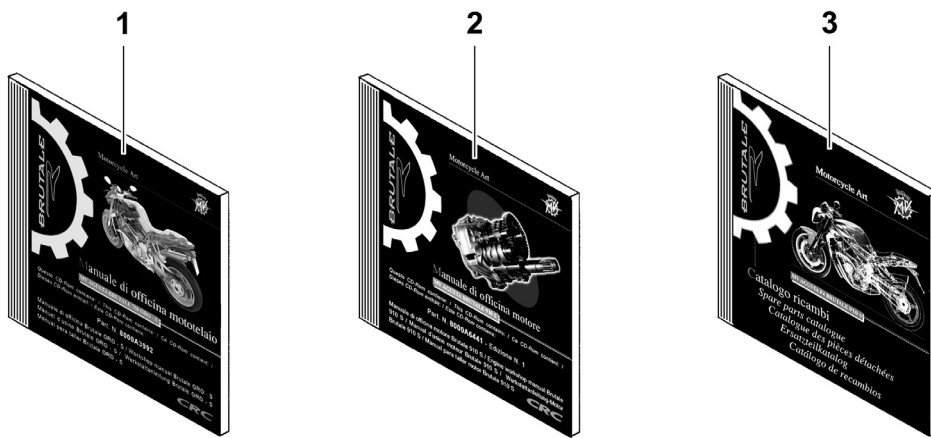



N.	Code	Q.ty	Note	B5 990 R	1090 RR	Brutale	Descrizione	Description	► I FRAME I ►	► I ENGINE I ►
1	8000B3254	1		•	•	•	Catalogo ricambi	Spare parts catalogue		
2	8000B3257	1		•	•	•	CD-Rom Manuale officina motore	Engine Workshop manual CD-Rom		
3	8000B3255	1		•	•	•	CD-Rom Manuale officina mototelaio	Motorcycle workshop manual CD-Rom		
4	8000B4023	1		•			Assieme documentazione di prodotto	Product documentation assy		
4	8000B4025	1	USA	•			Assieme documentazione di prodotto	Product documentation assy		
4	8000B4024	1			•		Assieme documentazione di prodotto	Product documentation assy		
4	8000B4026	1	USA		•		Assieme documentazione di prodotto	Product documentation assy		
4	8000B4576	1				•	Assieme documentazione di prodotto	Product documentation assy		
4	8000B4577	1	USA			•	Assieme documentazione di prodotto	Product documentation assy		
5	8000B4120	1		•	•	•	Form attivazione garanzia	Warranty booklet		
6	8000B3250	1		•	•	•	Chiave USB documentazione di prodotto	Product documentation USB key		
7	800093414	1		•	•	•	Portadocumenti	Document holder		
8	8A0099351	1		•	•	•	Borsa attrezzi completa	Complete tool box		
9	800089013	1		•	•	•	Chiave candela	Spark plug spanner		
10	8000A8617	1		•	•	•	Kit mantenimento di carica batteria	Battery charge maintenance kit		
10	8000A9372	1	USA	•	•	•	Kit mantenimento di carica batteria	Battery charge maintenance kit		
11	8000A8618	1		•	•	•	Cavo mantenimento di carica batteria	Battery charge maintenance cable		



ATTREZZATURE DI SERVIZIO (CICLISTICA)

SERVICE TOOLS (FRAME) • MATÉRIEL (PARTIE CYCLE)

SPEZIALWERKZEUG (RAHMEN) • UTILLAJE DE SERVICIO (MOTOCICLETA)

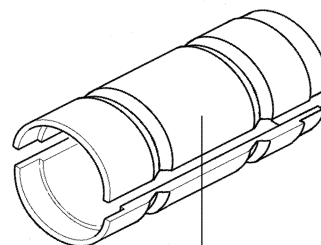
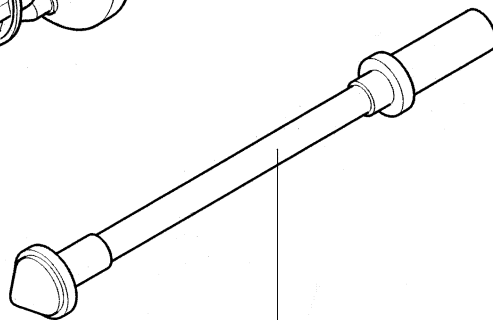
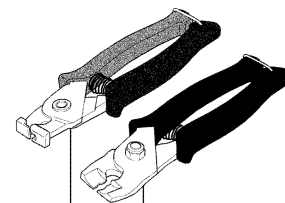
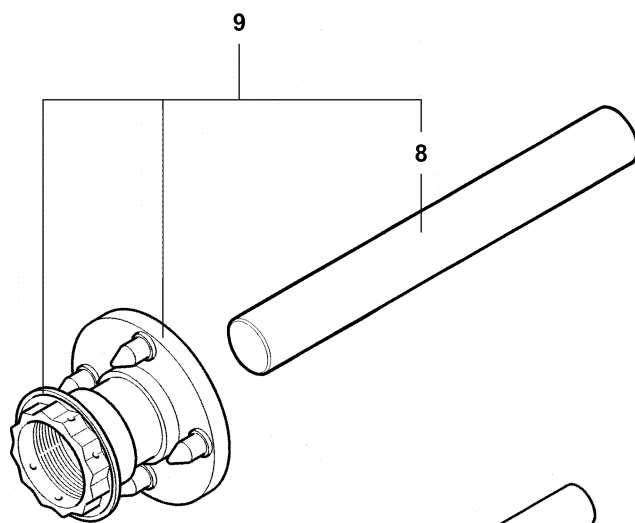
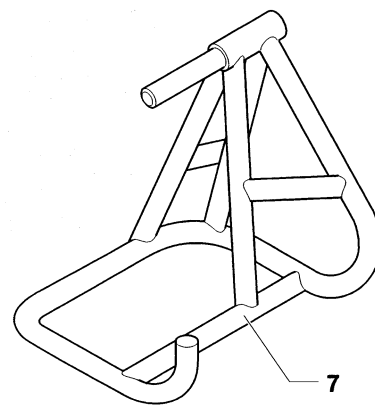
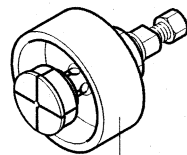
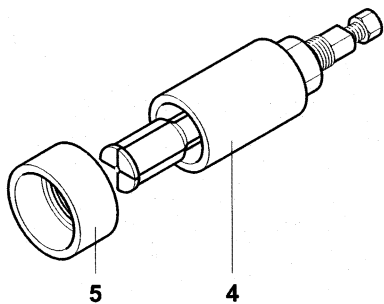
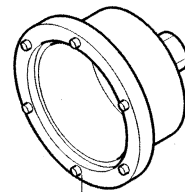
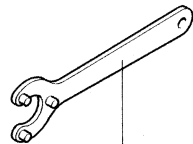
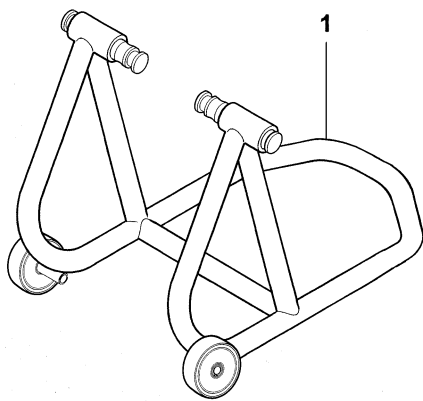

ATTREZZATURE DI SERVIZIO (CICLISTICA)

SERVICE TOOLS (FRAME) • MATÉRIEL (PARTIE CYCLE)

SPEZIALWERKZEUG (RAHMEN) • UTILLAJE DE SERVICIO (MOTOCICLETA)



N.	Code	Q.ty	Note	B5 990 R	1090 RR	Brutale	Descrizione	Description	► I FRAME I ►	► I ENGINE I ►
1	800095830	1		•	•	•	Cavalletto anteriore	Front stand		
2	800091645	1		•	•	•	Chiave ghiera cuscinetti di sterzo	Steering bearing pin wrench		
3	800092857	1		•	•	•	Chiave ghiera eccentrico sterzo	Steering cam ring nut wrench		
4	800092860	1		•	•	•	Estrattore cuscinetti forcellone	Fork bearings puller		
5	800092861	1		•	•	•	Boccola estrattore cuscinetti forcellone	Fork bearing puller bushing		
6	8000B4416	1		•	•	•	Estrattore cuscinetti ruota anteriore	Front wheel bearings puller		
7	800092642	1		•	•	•	Cavalletto posteriore	Rear stand		
8	8000A1953	1		•	•	•	Perno per albero di centraggio	Pin for centering shaft		
9	800092865	1		•	•	•	Attr. bilanciamento ruota posteriore	Rear wheel balancing tool		
10	800095850	1		•	•	•	Pinza montaggio/ smontaggio fascette clic R	Pliers for clic R clamps assembly/ disassembly		
11	800098321	1		•	•	•	Pinza inclinata monta fascette clic R	Clic R clamp fitting pliers		
12	800092866	1		•	•	•	Attrezzo montaggio pacco forcellone	Fork pack assembly tool		
13	8000A1039	1		•	•	•	Attrezzo parapolvere e paraolio	Dust cover and oil splash guard tool		



ATTREZZATURE DI SERVIZIO (CICLISTICA)

SERVICE TOOLS (FRAME) • MATÉRIEL (PARTIE CYCLE)

SPEZIALWERKZEUG (RAHMEN) • UTILLAJE DE SERVICIO (MOTOCICLETA)

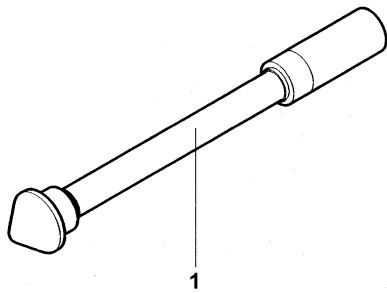

1

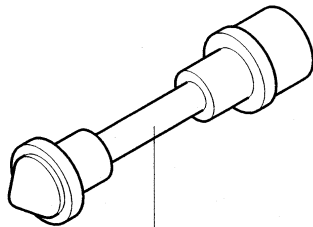

2

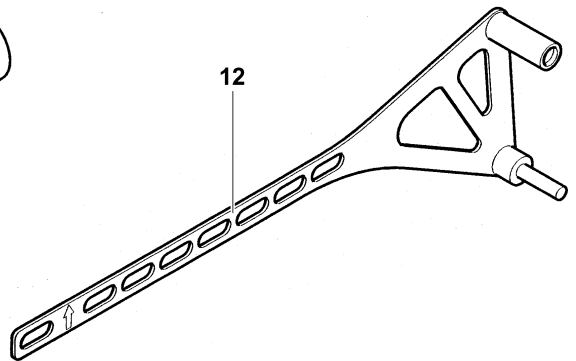

12

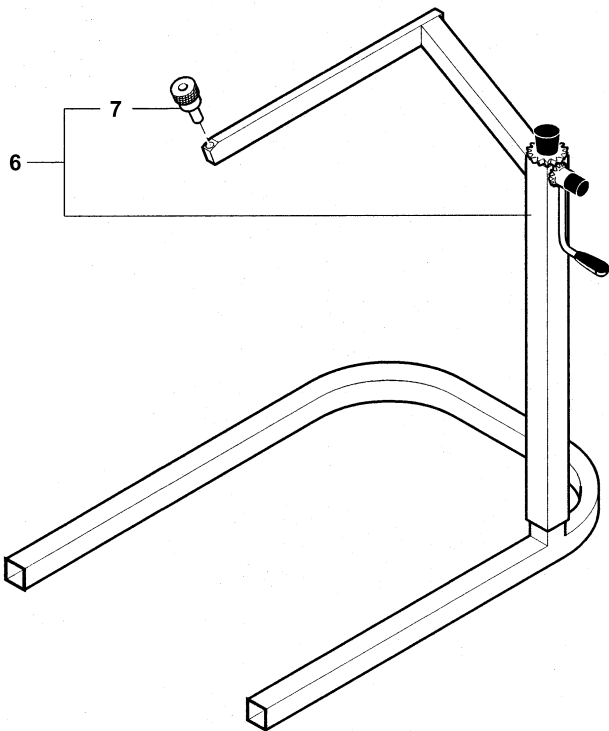

6

7

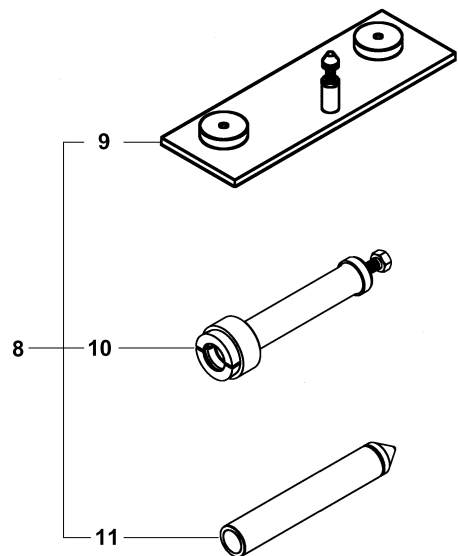

9

8

10

11

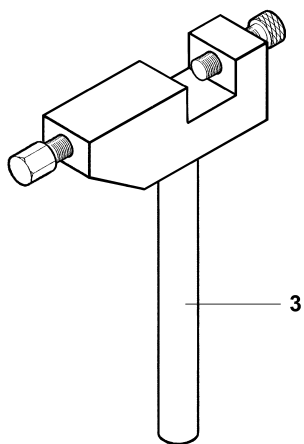

3

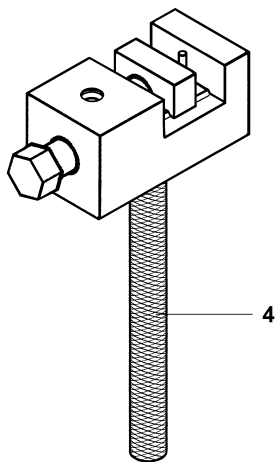

4

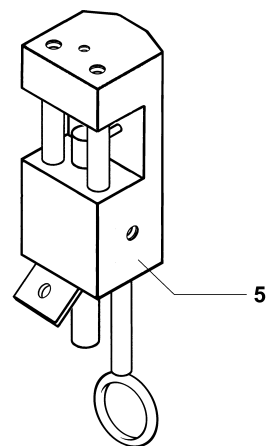

5

ATTREZZATURE DI SERVIZIO (CICLISTICA)

SERVICE TOOLS (FRAME) • MATÉRIEL (PARTIE CYCLE)

SPEZIALWERKZEUG (RAHMEN) • UTILLAJE DE SERVICIO (MOTOCICLETA)



N.	Code	Q.ty	Note	B5 990 R	1090 RR	Brutale	Descrizione	Description	► I FRAME I ►	► I ENGINE I ►
1	800092867	1		•	•	•	Attrezzo montaggio pacco bilanciere	Equaliser pack tool		
2	8000B4421	1		•	•	•	Attrezzo cuscinetti ruota anteriore	Front wheel bearings tool		
3	8000B1439	1		•	•	•	Attrezzo taglio catena	Chain cutting tool		
4	8000B1456	1		•	•	•	Attrezzo chiusura catena	Chain joining tool		
5	8000B1457	1		•	•	•	Attrezzo ribaditura catena	Chain riveting tool		
6	800095807	1		•	•	•	Cavalletto anteriore	Front stand		
7	800095808	1		•	•	•	Perno cavalletto anteriore	Front stand pin		
8	800097887	1		•	•	•	Attrezzo cuscinetto perno di sterzo	Steering pin bearing tool		
9	800097888	1		•	•	•	Piastra di riscontro base di sterzo	Steering base plate		
10	800097889	1		•	•	•	Estrattore cuscinetto perno di sterzo	Steering pin bearing extractor		
11	800097890	1		•	•	•	Attrezzo montaggio cuscinetto perno di sterzo	Steering pin bearing assembly tool		
12	800093347	1		•	•	•	Asta settaggio sospens. posteriore	Rear suspension setting rod		



ATTREZZATURE DI SERVIZIO (MOTORE)

SERVICE TOOLS (ENGINE) • MATÉRIEL (MOTEUR)

SPEZIALWERKZEUG (MOTOR) • UTILLAJE DE SERVICIO (MOTOR)

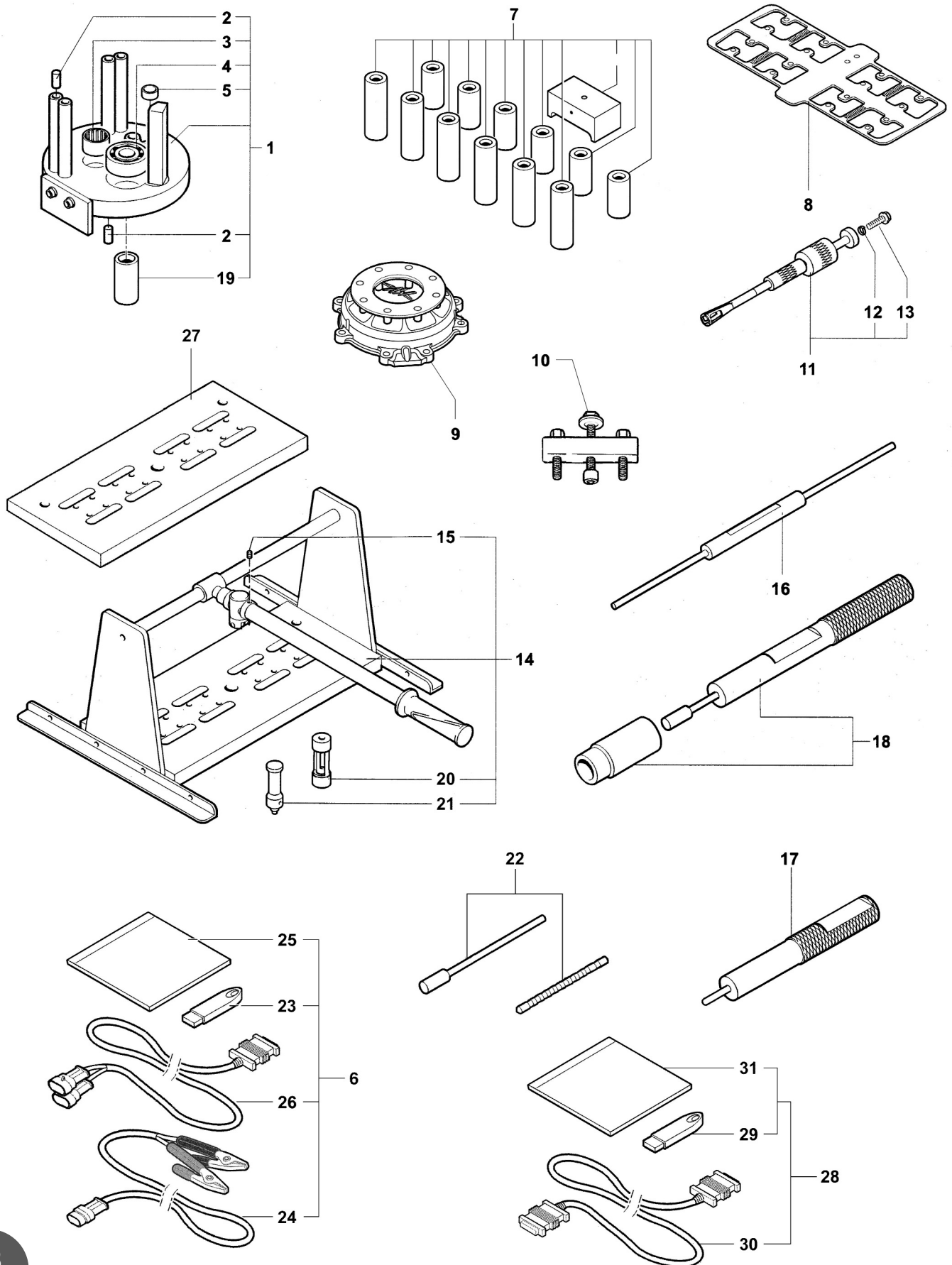

ATTREZZATURE DI SERVIZIO (MOTORE)

SERVICE TOOLS (ENGINE) • MATÉRIEL (MOTEUR)

SPEZIALWERKZEUG (MOTOR) • UTILLAJE DE SERVICIO (MOTOR)



N.	Code	Q.ty	Note	B5 990 R	1090 RR	Brutale	Descrizione	Description	► I FRAME I ►	► I ENGINE I ►
1	8A0094792	1		•	•	•	Attrezzo montaggio cambio	Gear change mounting tool		
2	800086119	8		•	•	•	Bussola di riferimento	Locating bush		
3	8000A1087	1		•	•	•	Cuscinetto	Bearing		
4	800098405	1		•	•	•	Cuscinetto	Bearing		
5	800087300	1		•	•	•	Cuscinetto	Bearing		
6	8A00A5394	1	①	•	•	•	Software diagnostica	Diagnostics software		
6	8B00A5394	1	②	•	•	•	Software diagnostica	Diagnostics software		
7	8000A3406	1		•	•	•	Attrezzo misura sporgenza pistoni	Piston projection measuring tool		
8	800094797	1		•	•	•	Lastra sagomata copri testa	Head cover shaped plate		
9	8000B4304	1		•	•	•	Attrezzo bloccaggio alternatore	Rotor locking tool		
10	8000B4305	1		•	•	•	Estrattore volano	Rotor puller		
11	800094798	1		•	•	•	Attrezzo smontaggio gommini valvola	Valve rubber caps removal tool		
12	62N115538	1		•	•	•	Rosetta elastica	Spring washer		
13	8C0069056	3		•	•	•	Vite TEF M8x30	Screw M8x30		
14	800094796	1		•	•	•	Attrezzo montaggio/ smontaggio valvole	Valve assembly/ disassembly tool		
15	800051521	2		•	•	•	Vite M4x6	Screw M4x6		
16	800095429	1		•	•	•	Tampone controllo	Gauge pad		
17	800095581	1		•	•	•	Punzone montaggio tenute valvola	Valve seals mounting punch		
18	8000A2385	1		•	•	•	Tampone montaggio guida	Guide mounting pad		
19	8A00B2859	1		•	•	•	Tubo D39-d27,2-L74,5	Pipe D39-d27,2-L74,5		
20	800095179	1		•	•	•	Attrezzo smontaggio semiconi	Half-cones disassembling tool		
21	800095180	1		•	•	•	Attrezzo montaggio semiconi	Half-cones assembling tool		
22	8000A2625	1		•	•	•	Broccia per guida valvole	Broach for valve guide		
23	8000A7688	1		•	•	•	Chiave USB	USB key		
24	8000A5393	1		•	•	•	Cavo interfaccia	Interface cable		
25	8C0093878	1	①	•	•	•	CD-Rom per software diagnostica	Diagnostic software CD-Rom		
25	8D0093878	1	②	•	•	•	CD-Rom per software diagnostica	Diagnostic software CD-Rom		
26	8000A7689	1		•	•	•	Adattatore USB/Seriale	Serial/USB adapter		
27	8000A9639	1	③	•	•	•	Piastra di base	Base plate		
28	8000B2114	1	①	•	•	•	Software programmazione centralina	Power unit programming software		
28	8A00B2114	1	②	•	•	•	Software programmazione centralina	Power unit programming software		

① Versione Windows 98 - Windows 98 version - Version Windows 98 - Windows 98 Version - Versión Windows 98

② Versione Windows Vista - Windows Vista version - Version Windows Vista - Windows Vista Version - Versión Windows Vista

③ Da utilizzare con il part. N° 14 (Cod. 800094796) - To be used with part No. 14 (Code No. 800094796) - Employez avec le pièce No° 14 (Code N° 800094796) - Mit Teil nr. 14 (Kennziffer Nr. 800094796) verwendet werden - Utilizar con la pieza N° 14 (Cod. N° 800094796).

J03

4



ATTREZZATURE DI SERVIZIO (MOTORE)

SERVICE TOOLS (ENGINE) • MATÉRIEL (MOTEUR)

SPEZIALWERKZEUG (MOTOR) • UTILLAJE DE SERVICIO (MOTOR)

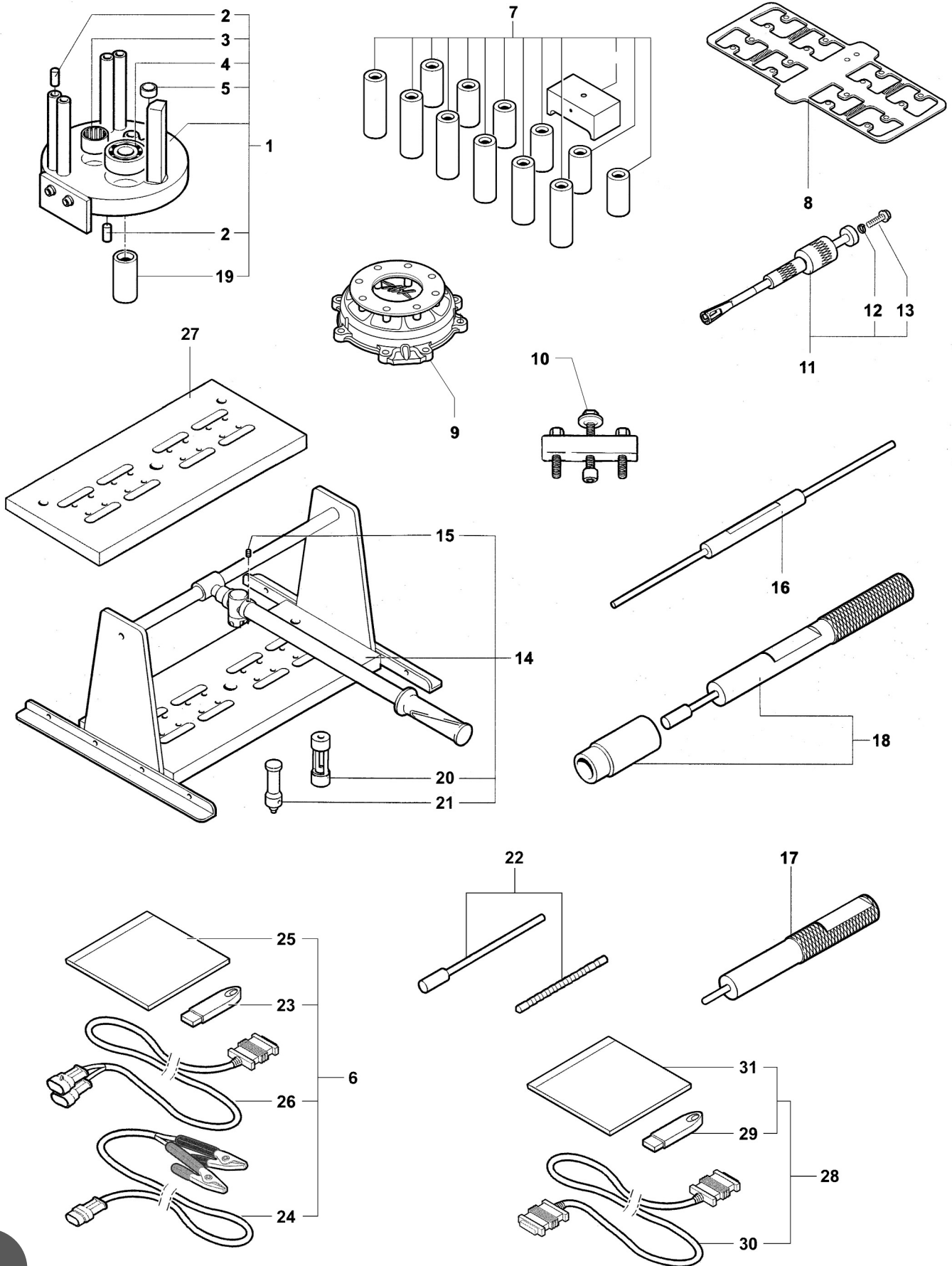

ATTREZZATURE DI SERVIZIO (MOTORE)

SERVICE TOOLS (ENGINE) • MATÉRIEL (MOTEUR)

SPEZIALWERKZEUG (MOTOR) • UTILLAJE DE SERVICIO (MOTOR)



N.	Code	Q.ty	Note	B5 990 R	1090 RR	Brutale	Descrizione	Description	► FRAME ►	► ENGINE ►
29	8000B2116	1		•	•	•	Chiave USB	USB key		
30	8000B2117	1	❶	•	•	•	Cavo seriale	Serial cable		
30	8A00B2117	1	❷	•	•	•	Cavo seriale	Serial cable		
31	8000B2118	1	❶	•	•	•	CD-Rom per software centralina	Power unit software CD-Rom		
31	8A00B2118	1	❷	•	•	•	CD-Rom per software centralina	Power unit software CD-Rom		

❶ Versione Windows 98 - Windows 98 version - Version Windows 98 - Windows 98 Version - Versión Windows 98

❷ Versione Windows Vista - Windows Vista version - Version Windows Vista - Windows Vista Version - Versión Windows Vista





ATTREZZATURE DI SERVIZIO (MOTORE)

SERVICE TOOLS (ENGINE) • MATÉRIEL (MOTEUR)

SPEZIALWERKZEUG (MOTOR) • UTILLAJE DE SERVICIO (MOTOR)

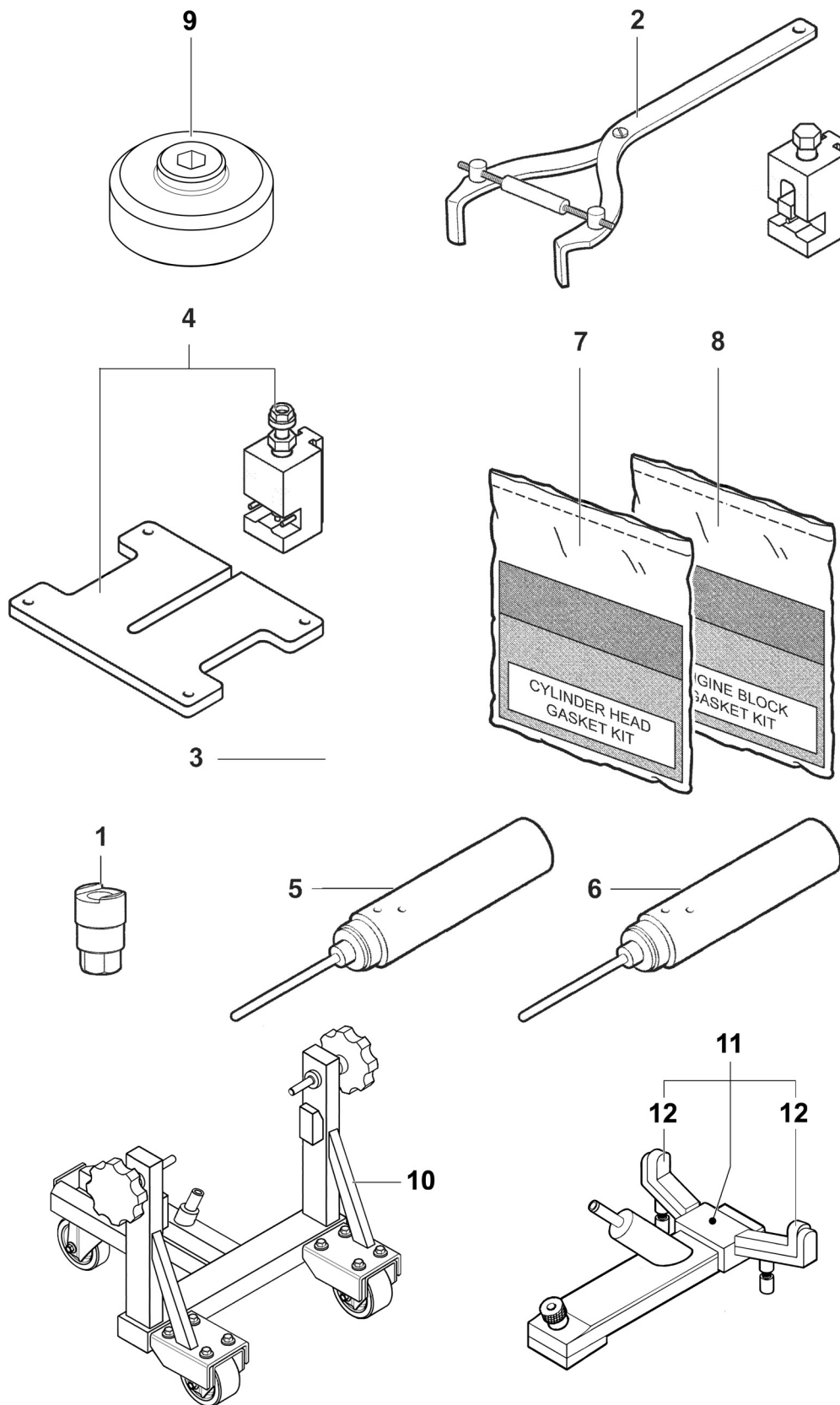

ATTREZZATURE DI SERVIZIO (MOTORE)

SERVICE TOOLS (ENGINE) • MATÉRIEL (MOTEUR)

SPEZIALWERKZEUG (MOTOR) • UTILLAJE DE SERVICIO (MOTOR)



N.	Code	Q.ty	Note	B5 990 R	1090 RR	Brutale	Descrizione	Description	► I FRAME I ►	► I ENGINE I ►
1	8000B2051	1		•	•	•	Attrezzo fissaggio vite scarico	Exhaust screw fixing tool		
2	800079015	1		•	•	•	Attrezzo bloccaggio frizione	Clutch blocking tool		
3	8000A2280	1		•	•	•	Attrezzo chiusura catena distribuzione	Timing chain mounting tool		
4	8000A2281	1		•	•	•	Attrezzo apertura catena distribuzione	Timing chain cutting tool		
5	800095318	1		•	•	•	Tampone per sede valvola scarico	Pad for exhaust valve seat		
6	800095319	1		•	•	•	Tampone per sede valvola aspirazione	Pad for intake valve seat		
7	8000B4309	1		•	•	•	Kit guarnizioni cilindro testa	Cylinder head gasket kit		
8	8000B4310	1		•	•	•	Kit guarnizioni cilindro basamento	Cylinder engine block gasket kit		
9	8000B3502	1		•	•	•	Attrezzo per tappo serbatoio espansione	Expansion tank cap tool		
10	8000B4417	1		•	•	•	Supporto montaggio motore	Engine assembly support		
11	8000B4366	1		•	•	•	Supporto serbatoio benzina	Fuel tank support		
12	8000B4652	2		•	•	•	Protezione per supporto serbatoio	Guard for fuel tank support		



VARIANTI ESTERO

VERSIONS FOR FOREIGN COUNTRIES • VARIANTES ÉTRANGER
 MODELLVARIANTEN AUSLAND • VARIANTES EXTRANJERO

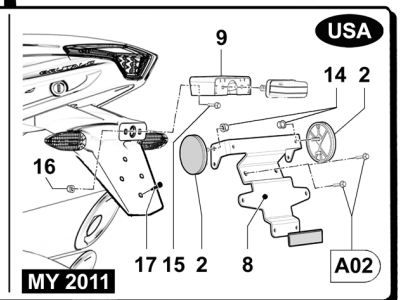
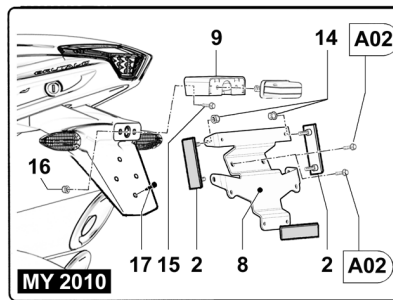
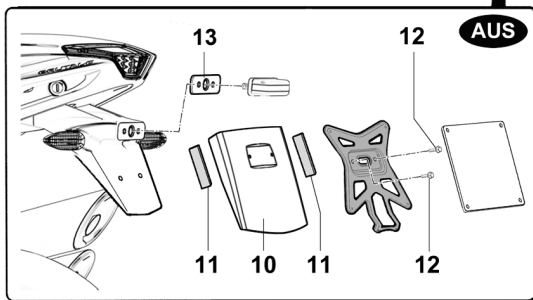
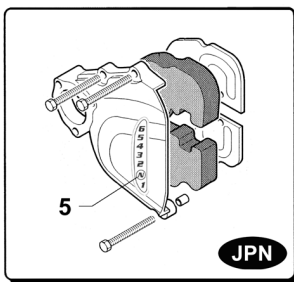
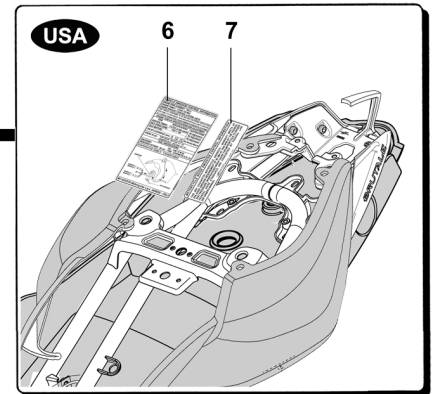
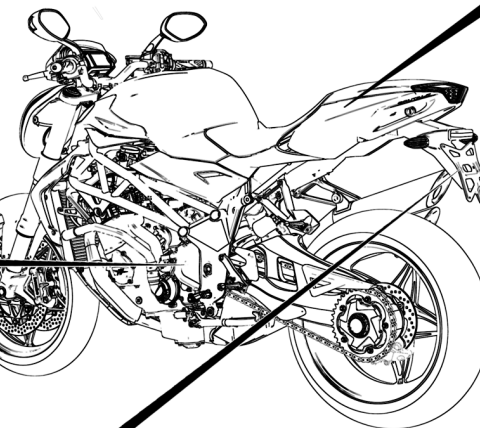
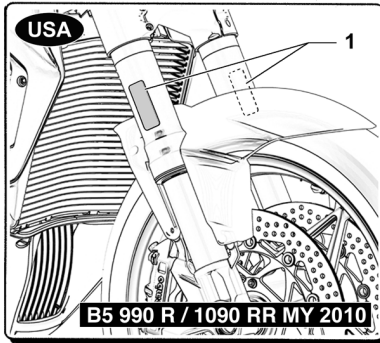
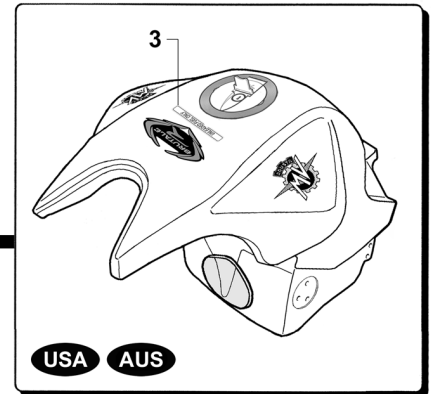
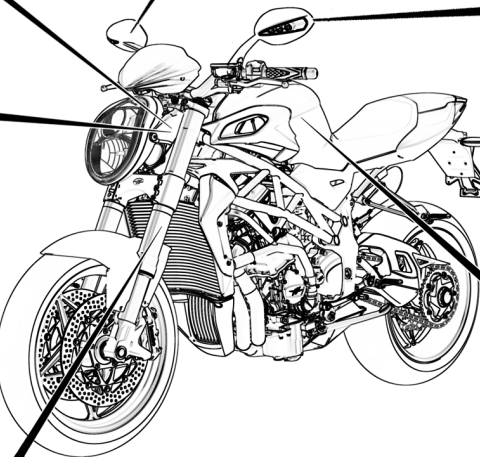
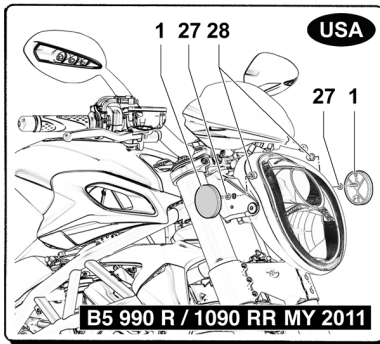
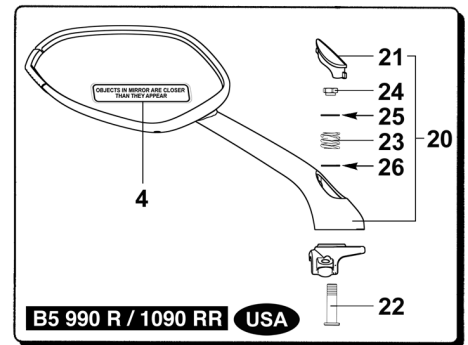
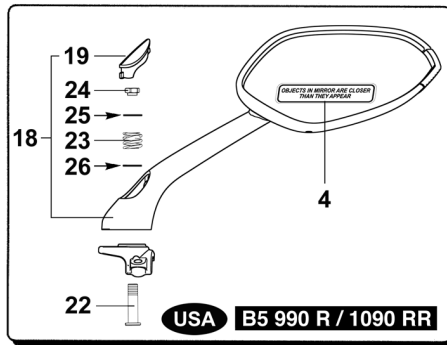
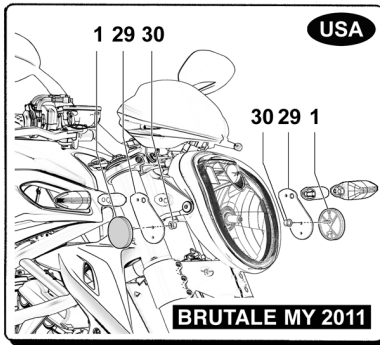

VARIANTI ESTERO

 VERSIONS FOR FOREIGN COUNTRIES • VARIANTES ÉTRANGER
 MODELLVARIANTEN AUSLAND • VARIANTES EXTRANJERO

N.	Code	Q.ty	Note	B5 990 R	1090 RR	Brutale	Descrizione	Description	► I FRAME I ►	► I ENGINE I ►
1	8000B4645	2	USA	•	•		Catadiottro anteriore	Front reflector	► I 002104	
1	80A0B4964	2	USA	•	•		Catadiottro anteriore	Front reflector	002105 I ►	
1	80A0B4964	2	USA			•	Catadiottro anteriore	Front reflector		
2	800090374	2	USA	•	•		Catadiottro posteriore	Rear reflector	► I 002104	
2	8000B4964	2	USA	•	•		Catadiottro posteriore	Rear reflector	002105 I ►	
2	8000B4964	2	USA			•	Catadiottro posteriore	Rear reflector		
3	800095366	1	AUS USA	•	•	•	Targhetta "Benzina verde"	Decal for "Unleaded fuel"		
4	800094019	2	USA	•	•	•	Decal specchietto retrovisore	Decal for "Rear mirror"		
5	800095842	1	JPN	•	•	•	Targhetta "Ordine marce"	Decal for "The order of gear"		
6	8000B3181	1	USA 1	•			Targhetta "Informazioni controllo emissioni"	Decal for "Vehicle emission control information"		
6	8000B3368	1	USA 1		•		Targhetta "Informazioni controllo emissioni"	Decal for "Vehicle emission control information"		
6	8000B5245	1	USA 1			•	Targhetta "Informazioni controllo emissioni"	Decal for "Vehicle emission control information"		
7	8000B3182	1	USA 1	•			Targhetta "Controllo emissioni"	Decal for "Noise emission control information"		
7	8A00B3182	1	USA 1		•		Targhetta "Controllo emissioni"	Decal for "Noise emission control information"		
7	8000B5244	1	USA 1			•	Targhetta "Controllo emissioni"	Decal for "Noise emission control information"		
8	8000B4644	1	USA	•	•		Flangia portatarga/ portacatadiottri	Number plate holder/retro- reflectors flange	► I 002104	
8	8000B4969	1	USA	•	•		Flangia portatarga/ portacatadiottri	Number plate holder/retro- reflectors flange	002105 I ►	
8	8000B4969	1	USA			•	Flangia portatarga/ portacatadiottri	Number plate holder/retro- reflectors flange		
9	8000B4643	1	USA	•	•	•	Distanziale luce targa	Number plate light spacer		
10	8000B3747	1	AUS	•	•	•	Flangia portatarga/ portacatadiottri	Number plate holder/retro- reflectors flange		
11	80B073832	2	AUS	•	•	•	Catadiottro	Retroreflector		
12	8G00B2681	2	AUS	•	•	•	Vite M6x25	M6x25 Screw		
13	8000B4231	1	AUS	•	•	•	Distanziale luce targa	Number plate light spacer		
14	8000B2706	4	USA	•	•		Dado M4	M4 nut	► I 002104	
14	8000B2707	2	USA	•	•		Dado M5	M5 nut	002105 I ►	
14	8000B2707	2	USA			•	Dado M5	M5 nut		
15	8C00B2680	2	USA	•	•	•	Vite M5x12	M5x12 screw		
16	8000B2707	2	USA	•	•	•	Dado M5	M5 nut		
17	800066308	1	USA	•	•	•	Antivibrante	Vibration damper		
18	8000B1658	1	USA	•	•		Specchietto retrovisore destro	Right-hand rearview mirror		

1 Per ordinare questo particolare, specificare il Model Year della motocicletta sul modulo di ordinazione. - In order to request this component, quote the Model Year of the motorcycle on the order form. - Pour se procurer ce composant, spécifiez le Model Year de la moto sur la forme d'ordre. - Für die Bestellung dieses Sonderbauteiles, geben Sie das Model Year des Motorrads auf dem Bestellformular an. - Para pedir dicho componente, indicar el Model Year de la motocicleta en el impreso de pedido.



K01

3

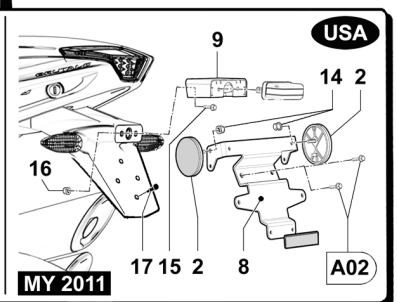
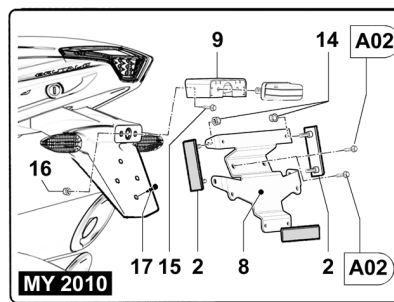
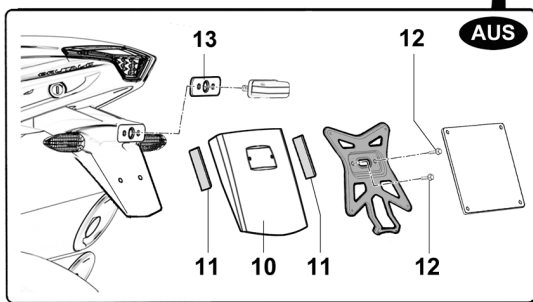
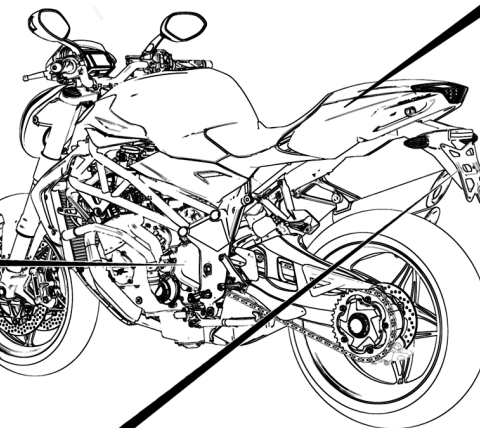
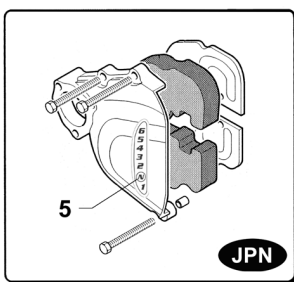
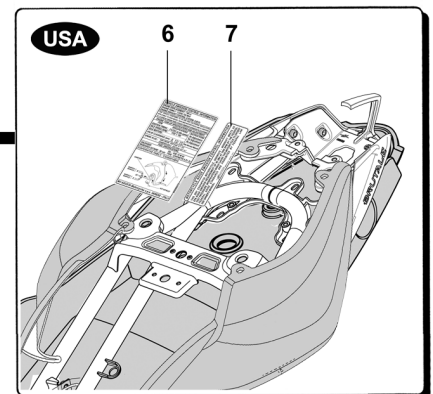
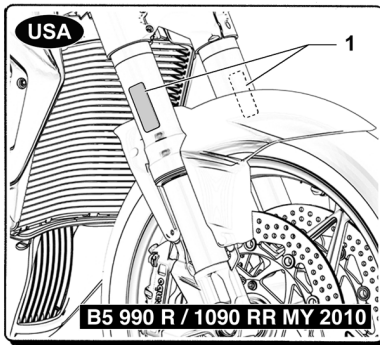
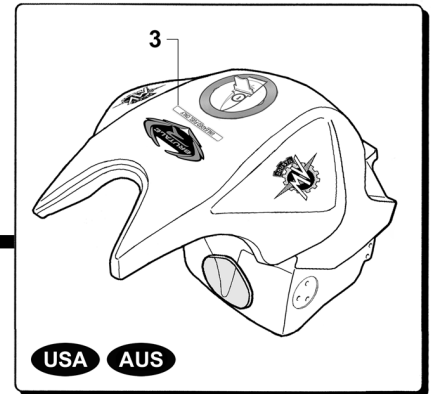
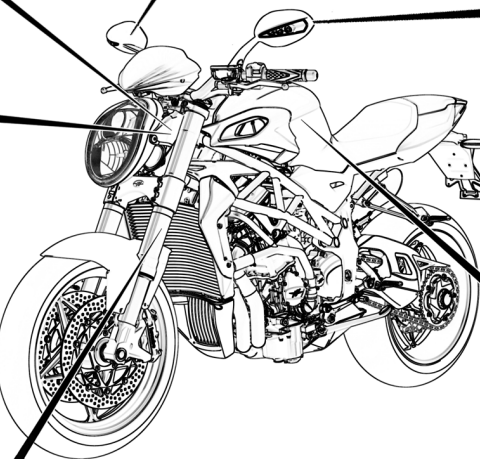
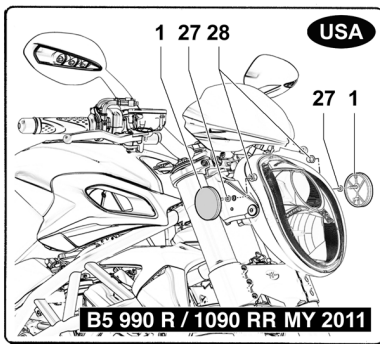
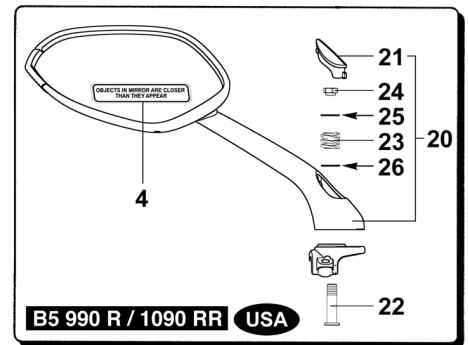
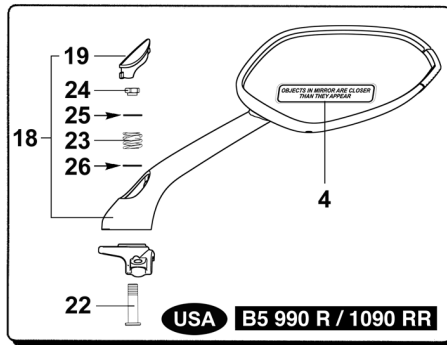
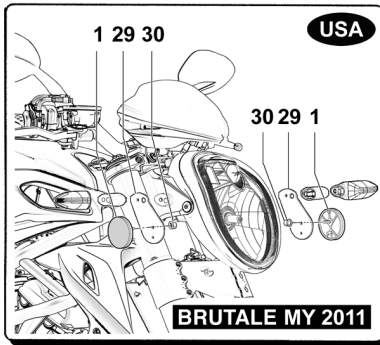

VARIANTI ESTERO

VERSIONS FOR FOREIGN COUNTRIES • VARIANTES ÉTRANGER
 MODELLVARIANTEN AUSLAND • VARIANTES EXTRANJERO



VARIANTI ESTERO

 VERSIONS FOR FOREIGN COUNTRIES • VARIANTES ÉTRANGER
 MODELLVARIANTEN AUSLAND • VARIANTES EXTRANJERO

N.	Code	Q.ty	Note	B5 990 R	1090 RR	Brutale	Descrizione	Description	► FRAME ►	► ENGINE ►
19	8000B4002	1	USA	•	•		Tappo per specchietto destro	RH mirror cap		
20	8000B1659	1	USA	•	•		Specchietto retrovisore sinistro	Left-hand rearview mirror		
21	8000B4001	1	USA	•	•		Tappo per specchietto sinistro	LH mirror cap		
22	8A0099289	2	USA	•	•		Perno	Pin		
23	80A099290	2	USA	•	•		Molla	Spring		
24	8000B2678	2	USA	•	•		Dado M8	M8 nut		
25	8000B2727	2	USA	•	•		Rosetta superiore	Upper washer		
26	8000B2724	2	USA	•	•		Rosetta inferiore	Lower washer		
27	8000B5021	2	USA	•	•		Distanziale	Spacer	002105 ►	
28	80A0A3886	2	USA	•	•		Dado M5	M5 nut	002105 ►	
29	8000B5421	2	USA			•	Staffa catadiottro anteriore	Front reflector bracket		
30	8000B2707	2	USA			•	Dado M5	M5 nut		



K01

3

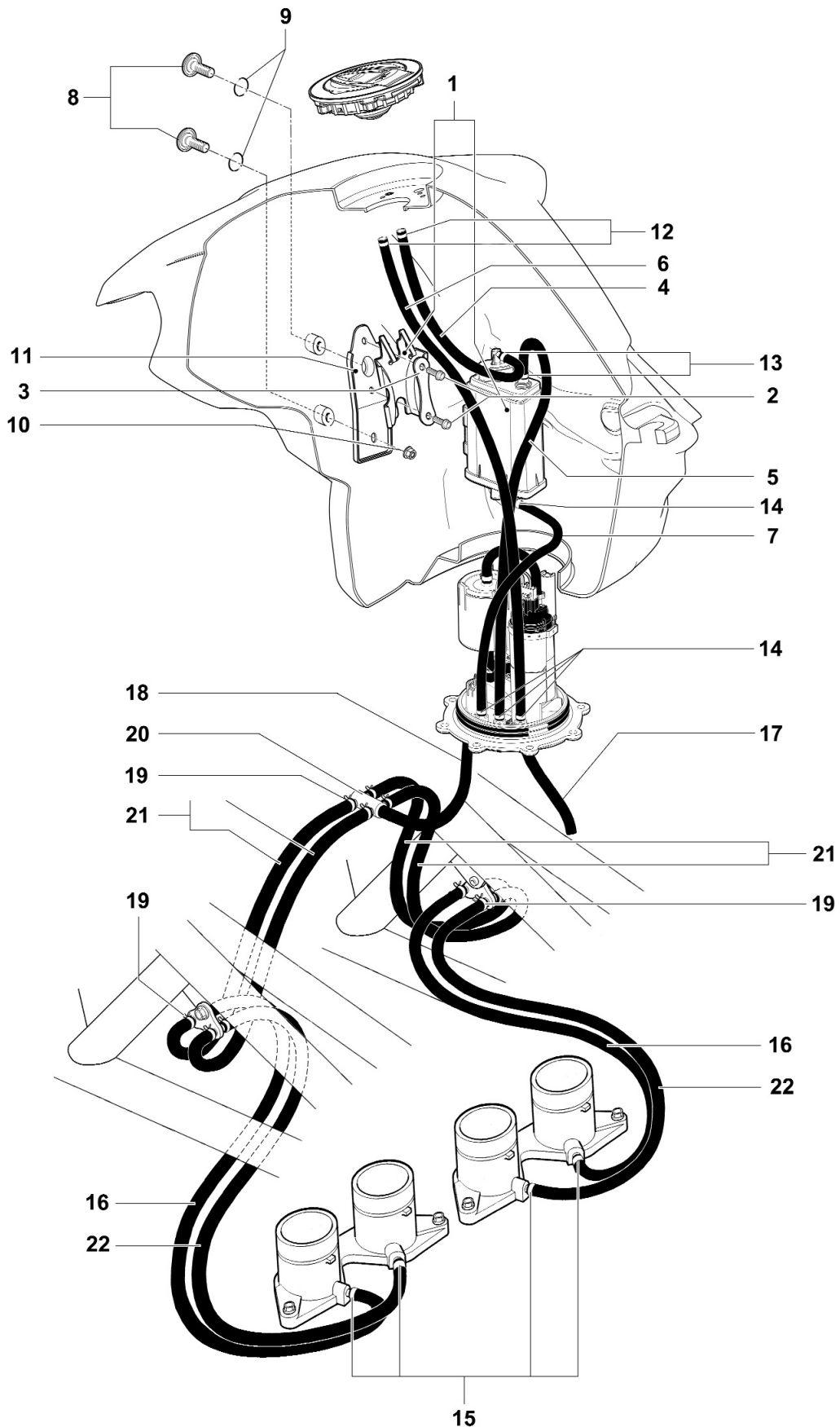

ASSIEME CANISTER (USA)

CARBON CANISTER ASSEMBLY (USA) • ENSEMBLE CANISTER (USA)
BAUGRUPPE CARBONKANISTER (USA) • CONJUNTO CANISTER (USA)



ASSIEME CANISTER (USA)CARBON CANISTER ASSEMBLY (USA) • ENSEMBLE CANISTER (USA)
BAUGRUPPE CARBONKANISTER (USA) • CONJUNTO CANISTER (USA)

N.	Code	Q.ty	Note	Brutale 990 R	Brutale 1090 RR	Brutale	► I FRAME I ►	► I ENGINE I ►
1	800097083	1	USA	•	•	•		
2	8A00B2680	2	USA	•	•	•		
3	80A097086	1	USA	•	•	•		
4	8C0090940	1	USA	•	•	•		
5	800097089	1	USA	•	•	•		
6	8C0090940	1	USA	•	•	•		
7	8000B3443	1	USA	•	•	•		
8	80A099373	2	USA	•	•	•		
9	8A0023116	2	USA	•	•	•		
10	8000B2707	1	USA	•	•	•		
11	8AA097087	1	USA	•	•	•		
12	8C0091687	2	USA	•	•	•		
13	800096458	2	USA	•	•	•		
14	8B0092256	4	USA	•	•	•		
15	800096458	4	USA	•	•	•		
16	8A0091037	2	USA	•	•	•		
17	800098950	1	USA	•	•	•		
18	800098715	1	USA	•	•	•		
19	8AA091634	12	USA	•	•	•		
20	800097088	1	USA	•	•	•		
21	800097090	4	USA	•	•	•		
22	8C0091037	2	USA	•	•	•		

INDICE CODICI / DENOMINAZIONI

 CODEX / DESIGNATION INDEX • INDEX CODES / DÉNOMINATIONS
 INHALTSVERZEICHNIS CODE • ÍNDICE CÓDIGOS / DENOMINACIONES

Code	Denominazione	Description	Désignation	Bezeichnung	Descripción	Table	N°
60N302515	VITE M6X50	M6X50 SCREW	VIS M6X50	SCHRAUBE M6X50	TORNILLO M6X50	G09	9
60ND02461	VITE M4X10	M4X10 SCREW	VIS M4X10	SCHRAUBE M4X10	TORNILLO M4X10	G08	45
60ND02466	VITE M4X20	M4X20 SCREW	VIS M4X20	SCHRAUBE M4X20	TORNILLO M4X20	G11	22
60ND02509	VITE M6X20	M6X20 SCREW	VIS M6X20	SCHRAUBE M6X20	TORNILLO M6X20	G13	5
						G17	12
60ND02520	VITE M6X75	M6X75 SCREW	VIS M6X75	SCHRAUBE M6X75	TORNILLO M6X75	D03	13
						D04	3
60ND02524	VITE M6X95	M6X95 SCREW	VIS M6X95	SCHRAUBE M6X95	TORNILLO M6X95	D03	13
						D04	3
60ND02558	VITE M8X35	M8X35 SCREW	VIS M8X35	SCHRAUBE M8X35	TORNILLO M8X35	G02	9
60ND07331	VITE M5X22	M5X22 SCREW	VIS M5X22	SCHRAUBE M5X22	TORNILLO M5X22	G15	9
60ND07335	VITE M6X16	M6X16 SCREW	VIS M6X16	SCHRAUBE M6X16	TORNILLO M6X16	G14	18
61ND15062	DADO	SPRING	ECROU	MUTTER	TUERCA	D02	26
62N015676	ROSETTA	WASHER	RONDELLE	UNTERLEGSCHIEBE	ARANDELA	G15	2
62N015682	ROSETTA	WASHER	RONDELLE	UNTERLEGSCHIEBE	ARANDELA	G01	57
62N115538	ROSETTA ELASTICA	SPRING WASHER	RONDELLE ELASTIQUE	FEDERRING	ARANDELA ELASTICA	J03	12
62ND15548	ROSETTA	WASHER	RONDELLE	UNTERLEGSCHIEBE	ARANDELA	F01	8
						F06	13
66N021202	ANELLO ELASTICO	SNAP RING	CIRCLIP	SPRENGRING	ARO	G06	20
						G16	25
						G17	33
66N021208	ANELLO ELASTICO	SNAP RING	CIRCLIP	SPRENGRING	ARO	G02	14
66N021270	ANELLO ELASTICO	SNAP RING	CIRCLIP	SPRENGRING	ARO	G14	13
66N021306	ANELLO ELASTICO	SNAP RING	CIRCLIP	SPRENGRING	ARO	G17	27
66N021313	ANELLO ELASTICO	SNAP RING	CIRCLIP	SPRENGRING	ARO	G05	3
66N221210	ANELLO ELASTICO	SNAP RING	CIRCLIP	SPRENGRING	ARO	G10	14
						G10	30
6AND55034	SPINA ELASTICA	SPRING PIN	GOUPILLE FENDUE	SPANNSTIFT	PUA ELASTICA	D03	35
						D04	29
6AND55037	SPINA ELASTICA	SPRING PIN	GOUPILLE FENDUE	SPANNSTIFT	PUA ELASTICA	B03	17
6BN021507	SFERA D 1/4"	BALL	BILLE	KUGEL	ESFERA	A02	26
80001199	ANELLO DI TENUTA	GROMMET	BAGUE D'ETANCHEITE	DICHTUNGSRING	RETEN	D02	29
80007719	BOCCOLA DI CENTRAGGIO	CENTERING BUSH	PION DE CENTRAGE	ZENTRIERBUCHSE	CASQUILLO DE CENTRAJE	G01	9
						G01	45
800017040	CUSCINETTO A SFERE	BALL BEARING	ROULÉMENT À BILLES	KUGELLAGER	COJINETE DE BOLAS	G14	12
800017679	ANELLO DI TENUTA	GROMMET	BAGUE D'ETANCHEITE	DICHTUNGSRING	RETEN	G08	20
800018422	ANELLO DI TENUTA	GROMMET	BAGUE D'ETANCHEITE	DICHTUNGSRING	RETEN	G05	22
800019971	RULLINO D4X15.8	NEEDLE	PION	STIFT	RODILLO	G02	8
						G06	16
800021480	ROSETTA	WASHER	RONDELLE	UNTERLEGSCHIEBE	ARANDELA	C02	18
						C03	16
						D02	36
						D03	19
						D04	11
800022551	ANELLO DI TENUTA	GROMMET	BAGUE D'ETANCHEITE	DICHTUNGSRING	RETEN	G15	4
800023105	ANELLO DI TENUTA	GROMMET	BAGUE D'ETANCHEITE	DICHTUNGSRING	RETEN	B04	25
						B05	25
800023106	ANELLO DI TENUTA	GROMMET	BAGUE D'ETANCHEITE	DICHTUNGSRING	RETEN	G01	64
800023108	ANELLO DI TENUTA	GROMMET	BAGUE D'ETANCHEITE	DICHTUNGSRING	RETEN	G04	5
800023113	ANELLO DI TENUTA	GROMMET	BAGUE D'ETANCHEITE	DICHTUNGSRING	RETEN	G04	29
800023114	ANELLO DI TENUTA	GROMMET	BAGUE D'ETANCHEITE	DICHTUNGSRING	RETEN	D01	21
						D02	38
800023118	ANELLO DI TENUTA	GROMMET	BAGUE D'ETANCHEITE	DICHTUNGSRING	RETEN	B04	20
						B05	20
800035728	CAPPELOTTO	CAP	CACHE	KAPPE	CAPUCHÓN	G01	30
800038520	RULLINO D4X8	NEEDLE	PION	STIFT	RODILLO	G11	19
800041039	ANTIVIBRANTE	VIBRATION-DAMPER	ANTI-VIBRATIONS	SCHWINGUNGSDÄMPFER	ANTIVIBRANTE	E05	26

INDICE CODICI / DENOMINAZIONI

 CODEX / DESIGNATION INDEX • INDEX CODES / DÉNOMINATIONS
 INHALTSVERZEICHNIS CODE • ÍNDICE CÓDIGOS / DENOMINACIONES

Code	Denominazione	Description	Désignation	Bezeichnung	Descripción	Table	N°
800042676	PUNTALE PER SALTARELLO	RATCHET PUSH ROD	POUSSOIR DE CLIQUET	METALLSPITZE FÜR SPERRNOCKE	PUNTAL PARA MARTINETE	G11	24
800046511	ROSETTA	WASHER	RONDELLE	UNTERLEGSCHLEIBE	ARANDELA	B04	2
						B05	2
						B06	2
						B07	2
800046893	DADO A GRAFFETTA M6	M6 NUT	ECROU M6	MUTTER M6	TUERCA M6	G08	19
800047763	ROSETTA	WASHER	RONDELLE	UNTERLEGSCHLEIBE	ARANDELA	G01	56
800048245	DADO ELASTICO M6	SPRING NUT	ECROU AUTOFREINE	ELASTISCHE MUTTER	TUERCA ELASTICA	A02	8
						B01	10
						E01	2
						E05	4
						F03	26
						G08	37
800051191	CUSCINETTO	BEARING	ROULEMENT	LAGER	COJINETE	G11	36
800051521	VITE M4X6	SCREW	VIS	SCHRAUBE	TORNILLO	J03	15
800051549	BOCCOLA	BUSH	DOUILLE	BUCHSE	CASQUILLO	G01	33
						G04	6
						G06	2
						G11	38
800053259	PARAPOLVERE	DUST COVER	JOINT-POUSSIÈRE	STAUBSCHUTZRING	GUARDAPOLVO	C02	14
800053724	FASCETTA IN GOMMA	RUBBER CLAMP	COLLIER EN CAOUTCHOUC	GUMMISCHLEIBE	CINTA DE GOMA	F04	1
						F04	2
						F05	1
						F05	12
						G08	23
800056444	FASCETTA IN NYLON	NYLON CLAMP	COLLIER EN NYLON	NYLONSCHLEIBE	CINTA DE NYLON	F03	3
800056783	FASCETTA IN NYLON	NYLON CLAMP	COLLIER EN NYLON	NYLONSCHLEIBE	CINTA DE NYLON	D02	42
						F03	22
						G08	6
800060910	ROSETTA	WASHER	RONDELLE	UNTERLEGSCHLEIBE	ARANDELA	F01	30
800062651	ANTIVIBRANTE	VIBRATION-DAMPER	ANTI-VIBRATIONS	SCHWINGUNGSDÄMPFER	ANTIVIBRANTE	G08	30
						G08	32
800062652	BUSSOLA	BUSH	BAGUE	HÜLSE	CASQUILLO	G08	25
800064296	ANELLO DI TENUTA	GROMMET	BAGUE D'ÉTANCHEITE	DICHTUNGSRING	RETEN	G11	9
800064586	FASCETTA	CLAMP	COLLIER	SCHLEIBE	CINTA	G08	79
800064988	ROSETTA	WASHER	RONDELLE	UNTERLEGSCHLEIBE	ARANDELA	G03	7
						G05	16
800065814	PARAOLIO	OIL SEAL	JOINT A LEVRE	ÖHLDIHRING	RETENEDOR DE ACEITE	G04	8
800066308	ANTIVIBRANTE	VIBRATION-DAMPER	ANTI-VIBRATIONS	SCHWINGUNGSDÄMPFER	ANTIVIBRANTE	K01	17
800066339	TAMPONE	PAD	TAMPON	PUFFER	TAPON	A02	7
800069149	ROSETTA	WASHER	RONDELLE	UNTERLEGSCHLEIBE	ARANDELA	E05	20
800069150	PIASTRINA SELLA	SADDLE PLATE	PLAQUETTE SELLE	SITZ BLECH	PLACA SILLIN	A02	32
800069156	ROSETTA	WASHER	RONDELLE	UNTERLEGSCHLEIBE	ARANDELA	G04	19
800069413	ANELLO DI TENUTA	GROMMET	BAGUE D'ÉTANCHEITE	DICHTUNGSRING	RETEN	G08	70
800069769	TAPPO CONICO	CONE-SHAPED PLUG	BOUCHON CONIQUE	KONISCHE GEWINDESCHRAUBE	TAPON CONOCO	G04	2
800070700	FASCETTA A MOLLA	SPRING CLAMP	COLLIER A RESSORT	FEDERSCHLEIBE	CINTA ELASTICA	D02	23
800070864	INTERRUTTORE STOP	STOP SWITCH	CONTACTEUR FEU STOP	BREMSLICHTSCHALTER	INTERRUPTOR DE STOP	D03	22
800070865	VITE INTERRUTTORE	SWITCH SCREW	VIS CONTACTEUR	SCHRAUBE FÜR SCHALTER	TORNILLO INTERRUPTOR	D03	23
800073529	OBLO' ISPEZIONE	OIL SIGHT GLASS	HUBLOT DE CONTROLE	SCHAUGLAS	VENTANILLA DE INSPECCION		
	LIVELLO OLIO			ÖLSTANDKONTROLLE	NIVEL DE ACEITE	G01	37
800079015	ATTREZZO BLOCCAGGIO	CLUTCH BLOCKING TOOL	OUTIL POUR LE BLOCAGE	WERKZEUG FÜR DAS	UTIL PARA EL BLOQUEO		
	FRIZIONE		D'EMBRAYAGE	KUPPLUNGSBLOCKIEREN	DEL EMBRAGUE	J04	2
800080691	GUARNIZIONE	GASKET	JOINT	DICHTUNG	EMPAQUE	G01	38
800081164	ANELLO DI TENUTA	GROMMET	BAGUE D'ÉTANCHEITE	DICHTUNGSRING	RETEN	B06	14
						B07	14



INDICE CODICI / DENOMINAZIONI
CODEX / DESIGNATION INDEX • INDEX CODES / DÉNOMINATIONS
INHALTSVERZEICHNIS CODE • ÍNDICE CÓDIGOS / DENOMINACIONES

Code	Denominazione	Description	Désignation	Bezeichnung	Descripción	Table	N°
800081174	DADO	SPRING	ECROU	MUTTER	TUERCA	B04	11
						B05	11
						B06	11
						B07	11
800081261	PERNO RINVIO DISTRIBUZIONE	TIMING TRANSMISSION PIN	AXE RENVOI DISTRIBUTION	VORGELEGEWELLE VENTILSTEUERUNG	PERNO REENVIO DISTRIBUCION	G05	2
800081280	MANICOTTO POMPA/ COLLETTORE	PUMP/MANIFOLD SLEEVE	MANCHON POMPE/ COLLECTEUR	VERBINDUNGSSTUTZEN PUMPE/KOLLEKTOR	MANGUITO ACOPLAMIENTO BOMBA/COLECTOR	G08	31
800081283	TERMOSTATO	THERMOSTAT	THERMOSTAT	THERMOSTAT	TERMOSTATO	G08	69
800081304	ANELLO DI TENUTA	GROMMET	BAGUE D'ETANCHEITE	DICHTUNGSRING	RETEN	G13	8
800081316	SEMICUSCINETTO DI BANCO (ROSSO)	CRANKSHAFT BEARING (RED)	HALF DEMI-COUSSINET DE PALIER (ROUGE)	KURBELWELLEN- LAGERSCHALENHÄLFTE (ROT)	SEMICOJINETE PRINCIPAL	G01	28
800081317	SEMICUSCINETTO DI BANCO (ROSSO)	CRANKSHAFT BEARING (RED)	HALF DEMI-COUSSINET DE PALIER (ROUGE)	KURBELWELLEN- LAGERSCHALENHÄLFTE (ROT) (ROJO)	SEMICOJINETE PRINCIPAL (ROJO)	G01	27
800081412	TAPPO DI CHIUSURA	PLUG	BOUCHON	VERSCHLUSS	TAPON	G01	26
800081422	CUSCINETTO	BEARING	ROULEMENT	LAGER	COJINETE	G01	13
800081478	CILINDRO COMANDO FRIZIONE	CLUTCH CONTROL CYLINDER	CYLINDRE RECEPTEUR DEBRAYAGE	KUPPLUNGSZYLINDER BUCHSE	CILINDRO ACCIONAMIENTO EMBRAGUE	G17	15
800081535	BOCCOLA	BUSH	DOUILLE	BUCHSE	CASQUILLO	G03	8
800081536	VITE M6X1	M6X1 SCREW	VIS M6X1	SCHRAUBE M6X1	TORNILLO M6X1	G03	6
800081547	DADO FISSAGGIO TESTA	HEAD STOP NUT	ECROU DE FIXATION CULASSE	MUTTER ZYLINDERKOPFBEFESTIGUNG	TUERCA FIJACION CULATA	G04	17
800081553	PATTINO FISSO	FIXED GUIDE SHOE	PATIN FIXE	FESTE KETTENFÜHRUNG	PATIN FIJO	G05	14
800081583	FORCELLA INNESTO MARCE	SHIFTING FORK	FOURCHETTE DE SELECTION	SCHALTGABEL	HORQUILLA ENGRANE MARCHA	G11	15
800081585	PERNO PER FORCELLA	FORK PIN	AXE DE FOURCHETTE	SCHALTGABELWELLE	PERNO PARA HORQUILLA	G11	17
800082695	PERNO	PIN	AXE	ZAPFEN	PERNO	D03	33
						D04	27
800082743	PERNO PASTIGLIE FRENO	BRAKE PADS PIN	PIVOT PASTILL. DE FREIN	ZAPFEN BREMSBELAG	PERNO PASTILLAS FRENO	C01	23
800082746	MOLLA RITEGNO PASTIGLIE	PAD CHECK SPRING	PLAQUETTE D'APPUI	RÜCKHALTEFEDER BREMSBELÄGE	MUELLE RETENCION PASTILLAS	C01	22
800082748	COPIA PASTIGLIE FRENO POSTERIORE	REAR BRAKE PADS	PAIRE DE PLAQUETTES FREIN ARRIÈRE	BREMSBELAGPAAR HINTERRADBREMSE	PAR DE PASTILLAS DE FRENO	C01	21
800084182	PASTIGLIA REGOLAZIONE GIOCO (SP.1.60)	CLEARANCE ADJUSTING PAD (THICKNESS 1.60)	PASTILLE DE CALAGE (SP.1.60)	EINSTELLPLÄTTCHEN VENTILSPIEL (STÄRKE 1.60)	PASTILLA REGULACION JUEGO (SP.1.60)	G05	8
800084858	DISTANZIALE	SPACER	ENTRETOISE	ABSTANDHALTER	DISTANCIADOR	B02	13
800084859	BUSSOLA SX FORCELLONE	FORK LH BUSH	DOUILLE G. BRAS OSCILLANT	LINKE SCHWINGENBUCHSE	CASQUILLO IZQUIERDA HORQUILLA	B01	7
800084872	DISTANZIALE	SPACER	ENTRETOISE	ABSTANDHALTER	DISTANCIADOR	B01	2
800084873	BUSSOLA DX FORCELLONE	FORK RH BUSH	BAGUE D. BRAS OSCILLANT	RECHTE SCHWINGENBUCHSE	CASQUILLO DER. HORQUILLA	B01	8
800084890	FLANGIA DISCO FRENO POSTERIORE	REAR BRAKE DISK FLANGE	FLASQUE DISQUE FREIN ARRIÈRE	BREMSSCHEIBENFLANSCH HINTERRADBREMSE	BRIDA DISCO FRENO TRASERO	C01	9
800084891	DADO M7	SPRING	ECROU	MUTTER	TUERCA	C01	13
800084893	ROSETTA	WASHER	RONDELLE	UNTERLEGSCHIEBE	ARANDELA	C01	16
800084894	ROSETTA	WASHER	RONDELLE	UNTERLEGSCHIEBE	ARANDELA	C01	32
800084898	FERMAGLIO	CLIP	JONC	KLEMMRING	BROCHE	C01	19
800084899	FERMAGLIO	CLIP	JONC	KLEMMRING	BROCHE	C01	34
800084903	DADO DX RUOTA POST.	REAR WHEEL RH NUT	ECROU D. ROUE ARRIERE	RECHTE MUTTER HINTERRAD	TUERCA DER. RUEDA TRASERA	C01	33
800084904	DADO SX RUOTA POST.	REAR WHEEL LH NUT	ECROU G. ROUE ARRIERE	LINKE MUTTER HINTERRAD	TUERCA IZQ. RUEDA TRASERA	C01	18
800084909	ANELLO DI TENUTA	GROMMET	BAGUE D'ETANCHEITE	DICHTUNGSRING	RETEN	C01	5
800084913	ANELLO ELASTICO	SNAP RING	CIRCLIP	SPRENGRING	ARO	C01	17
800084915	VITE DI FASATURA	TIMING SCREW	VIS DE CALAGE	SCHRAUBE PHASENAUSRICHTUNG	TORNILLO PARA FASE	A01	21
800084936	CUSCINETTO	BEARING	ROULEMENT	LAGER	COJINETE	B01	5
800084937	ANELLO DI TENUTA	GROMMET	BAGUE D'ETANCHEITE	DICHTUNGSRING	RETEN	B01	6
800084938	CUSCINETTO	BEARING	ROULEMENT	LAGER	COJINETE	B01	3

INDICE CODICI / DENOMINAZIONI

 CODEX / DESIGNATION INDEX • INDEX CODES / DÉNOMINATIONS
 INHALTSVERZEICHNIS CODE • ÍNDICE CÓDIGOS / DENOMINACIONES

Code	Denominazione	Description	Désignation	Bezeichnung	Descripción	Table	N°
800084939	ANELLO ELASTICO	SNAP RING	CIRCLIP	SPRENGRING	ARO	B01	4
800084945	CUSCINETTO	BEARING	ROULEMENT	LAGER	COJINETE	B02	11
800084946	ANELLO DI TENUTA	GROMMET	BAGUE D'ETANCHEITE	DICHTUNGSRING	RETEN	B02	12
800085071	VITE M6X35	SCREW	VIS	SCHRAUBE	TORNILLO	G04	7
800085493	BUSSOLA	BUSH	BAGUE	HÜLSE	CASQUILLO	G11	28
800085495	SALTARELLO FISSA MARCE	GEARS STOP RATCHET	DOIGT DE VERROUILLAGE	SPERRNOCKE GANGWAHL	TRIQUETE FIJACION MARCHAS	G11	25
800086107	ROSETTA	WASHER	RONDELLE	UNTERLEGSCHEIBE	ARANDELA	G11	27
800086114	PIASTRA	PLATE	PLAQUE	PLATTE	PLACA	G11	5
800086117	GUARNIZIONE	GASKET	JOINT	DICHTUNG	EMPAQUE	G11	2
800086119	BOCCOLA DI RIFERIMENTO	DOWEL BUSH	PION DE CENTRAGE	ZENTRIERBUCHSE	BOCCOLA DI RIFERIMENTO	G01	11
						J03	2
800086131	BOCCOLA	BUSH	DOUILLE	BUCHSE	CASQUILLO	G11	45
800086436	GHIERA	RING NUT	ECROU	GEWINDERING	VIROLA	B03	9
800086500	ANELLO DI TENUTA	GROMMET	BAGUE D'ETANCHEITE	DICHTUNGSRING	RETEN	B04	8
						B05	8
						B06	8
						B07	8
800086503	BOCCOLA	BUSH	DOUILLE	BUCHSE	CASQUILLO	B04	10
						B05	10
						B06	10
						B07	10
800086699	BUSSOLA	BUSH	BAGUE	HÜLSE	CASQUILLO	G10	3
800086702	ANELLO DI TENUTA	GROMMET	BAGUE D'ETANCHEITE	DICHTUNGSRING	RETEN	C01	15
800086726	RUOTA FONICA	PHONIC WHEEL	ROUE PHONIQUE	SENSOR RADDREHUNG	RUEDA FONICA	G02	7
800086727	DADO FISSAGGIO	PHONIC WHEEL STOP NUT	ECROU ANCRAGE	BEFESTIGUNGSMUTTER	TUERCA FIJACION		
	RUOTA FONICA		ROUE PHONIQUE	SENSOR RADDREHUNG	RUEDA FONICA	G02	6
800086735	PATTINO MOBILE	MOVABLE PAD	PATIN MOBILE	BEWEGLICHE KETTENFÜHRUNG	PATIN MOVIL	G05	17
800086737	ROSETTA	WASHER	RONDELLE	UNTERLEGSCHEIBE	ARANDELA	G01	14
800087300	CUSCINETTO	BEARING	ROULEMENT	LAGER	COJINETE	G01	12
						J03	5
800087441	SUPPORTO AMMORTIZZATORE	SHOCK ABSORBER SUPPORT	SUPPORT D'AMORTISSEUR	STOSSDÄMPFERBEFESTIGUNG	SOPORTE AMORTIGUADOR	B01	19
800087463	PIASTRINA	PLATE	PLAQUETTE	BLECH	PLACA	B01	12
800087465	PEDANA ANTERIORE SX	LH LOWER FOOTBOARD	CALE-PIED AVANT G.	VORDERE LINKE FUSSRASTE	ESTRIBO APOYAPIE DELANTERO IZQUIERDO	D01	7
800087466	PEDANA ANTERIORE DX	RH FRONT FOOTBOARD	CALE-PIED AVANT D.	VORDERE RECHTE FUSSRASTE	ESTRIBO APOYAPIE DELANTERO DERECHO	D02	7
800087752	ANELLO DI TENUTA	GROMMET	BAGUE D'ETANCHEITE	DICHTUNGSRING	RETEN	G04	16
800087784	SUPPORTO PATTINO MOBILE	MOVABLE PAD SUPPORT	SUPPORT PATIN MOBILE	HALTERUNG BEWEGLICHE KETTENFÜHRUNG	SOPORTE PATIN MOVIL	G05	18
800087785	PERNO PATTINO MOBILE	PIN FOR MOVABLE PAD	AXE POUR PATIN MOBILE	ZAPFEN FÜR BEWEGLICHE KETTENFÜHRUNG	PERNO PARA PATIN MOVIL	G05	19
800087792	GUARNIZIONE	GASKET	JOINT	DICHTUNG	EMPAQUE	G01	4
800088342	ASTA COMANDO FRIZIONE	CLUTCH CONTROL ROD	TIGE DE DEBRAYAGE	KUPPLUNGSSTANGE	VARILLA ACCIONAMIENTO EMBRAGUE	G09	16
						G17	14
800088347	SPUGNA INSONORIZZANTE	SOUNDPROOFING SPONGE	MOUSSE INSONORISANTE	SCHALLDÄMPFERSCHWAMM	ESPONJA INSONORIZANTE	G11	42
800088773	PERNO/COPIGLIA	PIN/SPLIT PIN	AXE/GOUPILLE FENDUE	ACHSE/SPLINT	PERNO/PASADOR	C02	12
800088776	MOLLA RITEGNO PASTIGLIE	PAD CHECK SPRING	PLAQUETTE D'APPUI	RÜCKHALTEFEDER BREMSBELÄGE	MUELLE RETENCION PASTILLAS	C02	11
800088777	COPIGLIE	SPLIT PINS	GOUPILLES FENDUES	SPLINT	PASADORES	C02	17
800089013	CHIAVE CANDELA	SPARK PLUG WRENCH	CLE A BOUGIE	KERZENSCHLÜSSEL	LLAVE PARA BUJIA	H01	9
800089274	ANELLO RITENUTA	RETAINING RING	JONC DE MAINTIEN	SCHLISSRING	RETEN	B04	7
						B05	7
						B06	7
						B07	7

INDICE CODICI / DENOMINAZIONI

 CODEX / DESIGNATION INDEX • INDEX CODES / DÉNOMINATIONS
 INHALTSVERZEICHNIS CODE • ÍNDICE CÓDIGOS / DENOMINACIONES

Code	Denominazione	Description	Désignation	Bezeichnung	Descripción	Table	N°		
800089275	DISTANZIALE	SPACER	ENTRETOISE	ABSTANDHALTER	DISTANCIADOR	B04	9		
						B05	9		
						B06	9		
						B07	9		
800089293	ANTIVIBRANTE	VIBRATION-DAMPER	ANTI-VIBRATIONS	SCHWINGUNGSDÄMPFER	ANTIVIBRANTE	E01	12		
						E04	17		
						E04	23		
						F01	3		
						F03	16		
						G13	29		
800089298	GOMMINO	RUBBER COVER	CAOUTCHOUC	GUMMI	GOMA	D01	18		
						D02	18		
800089300	PIASTRINA	PLATE	PLAQUETTE	BLECH	PLACA	B01	13		
800089302	ANTIVIBRANTE	VIBRATION-DAMPER	ANTI-VIBRATIONS	SCHWINGUNGSDÄMPFER	ANTIVIBRANTE	G16	4		
						G16	16		
800089313	POMPA FRENO POSTERIORE	REAR BRAKE PUMP	MAITRE-CYLINDRE DE FREIN ARRIERE	BREMSPUMPE HINTERRADBREMSE	BOMBA FRENO TRASERO	D02	20		
800089404	FASCETTA A VITE	SCREW CLAMP	COLLIER A VIS	SCHRAUBENSCHELLE	ABRAZADERA DE ROSCA	G13	6		
800089406	ANELLO TENUTA	GROMMET	BAGUE D'ETANCHEITE	DICHTUNGSRING	RETEN	G11	39		
800089410	ANELLO TENUTA	GROMMET	BAGUE D'ETANCHEITE	DICHTUNGSRING	RETEN	G11	7		
800089426	ROSETTA	WASHER	RONDELLE	UNTERLEGSCHIEBE	ARANDELA	G01	18		
800089445	RINVIO COMANDO DISTRIBUZIONE	TIMING CONTROL RENOI TRANSMISSION	COMMANDE DE DISTRIBUTION	VORGELEGE VENTILSTEUERUNG	REENVIO MANDO DISTRIBUCION	G05	1		
800089446	TENDICATENA	CHAIN TIGHTENER	TENDEUR DE CHAINE	KETTENSPELLER	TENSIONADOR DE CADENA	G05	21		
800089484	SPURGO	DRAIN VALVE	VIS DE PURGE	ENTLÜFTUNGSSCHRAUBE	ESPURGO	C01	24		
800089491	PARAPOLVERE	DUST COVER	JOINT-POUSSIÈRE	STAUBSCHUTZRING	GUARDAPOLVO	C01	25		
800089751	ROSETTA	WASHER	RONDELLE	UNTERLEGSCHIEBE	ARANDELA	A02	9		
						E05	9		
800089759	LEVA COMANDO CAMBIO	GEAR LEVER	LEVIER DE SELECTION	SCHALTPEDALHEBEL	PALANCA ACCIONAMIENTO CAMBIO	D01	16		
800089760	ECCENTRICO PER PEDALE	PEDAL ECCENTRIC	EXCENTRIQUE POUR PEDALE	EXZENTER FÜR HEBEL	ECCENTRICO PARA PEDAL	D01	17		
						D02	17		
800089770	SUPPORTO POMPA	PUMP SUPPORT	SUPPORT DE POMPE	BREMSPUMPENHALTERUNG	SOPORTE BOMBA	D02	30		
800089777	PIASTRINA	PLATE	PLAQUETTE	BLECH	PLACA	D01	5		
						D02	5		
800089784	STAFFA DX SERBATOIO	FUEL TANK RH SUPPORT	PATTE D. RESERVOIR	RECHTE TANKBEFESTIGUNG	SOPORTE DER. DEPOSITO	E04	20		
800089785	STAFFA SX SERBATOIO	FUEL TANK LH SUPPORT	PATTE G. RESERVOIR	LINKE TANKBEFESTIGUNG	SOPORTE IZQ. DEPOSITO	E04	21		
800089799	CAPPUCCIO SX	LH CAP	CAPUCHON G.	LINKE KAPPE	CAPUCHON IZQUIERDO	G13	17		
800089800	CAPPUCCIO DX	RH CAP	CAPUCHON D.	RECHTE KAPPE	CAPUCHON DERECHO	G13	18		
800089801	PORTATUBO	PIPE CARRIER	PORTE-CANALISATION	LEITUNGSHALTERUNG	PORTATUBO	G13	14		
800090184	SENSORE RPM MOTORE	ENGINE RPM SENSOR	CAPTEUR COMPTE-TOURS	SENSOR MOTORDREHZAHL	SENSOR RPM MOTOR	G15	3		
800090213	INTERRUTTORE PEDALE STOP	STOP PEDAL SWITCH	CONTACTEUR	BREMSLICHTSCHALTER	INTERRUPTOR PEDAL STOP				
						PEDALE DE STOP	BREMSPEDAL	F05	2
								F06	7
800090239	ANTIVIBRANTE	VIBRATION-DAMPER	ANTI-VIBRATIONS	SCHWINGUNGSDÄMPFER	ANTIVIBRANTE	F01	4		
						F06	7		
800090244	TUBO CON RIDUZIONE	PIPE WITH ADAPTER	MANCHON DE REDUCTION	LEITUNG MIT REDUZIERSTÜCK	TUBO CON REDUCCION	G08	53		
800090245	TUBO DI SPURGO	DRAIN PIPE	TUYAU DE PURGE	ENTLÜFTUNGSLEITUNG	TUBO DE ESPURGO	G08	51		
800090266	PIASTRINA	PLATE	PLAQUETTE	BLECH	PLACA	D03	5		
800090312	PROTEZIONE	PROTECTION	PROTECTION	ABDECKUNG	PROTECCION	D02	31		
800090314	SPINA ELASTICA	SPRING PIN	GOUPILLE FENDUE	SPANNSTIFT	PUA ELASTICA	D01	4		
						D02	4		
800090315	SERBATOIO OLIO FRENO POSTERIORE	REAR BRAKE FLUID SUPPLY TANK	RESERVOIR DE LIQUIDE FREIN ARRIERE	BREMSFLÜSSIGKEITSBEHÄLTER HINTERRADBREMSE	DEPOSITO ACEITE FRENO TRASERO	D02	21		
800090350	GUARNIZIONE	GASKET	JOINT	DICHTUNG	EMPAQUE	G13	9		
800090374	CATADIOTTRO	RETROREFLECTOR	REFLECTEUR	KATZENAUGE	CATAFARO	A02	17		
						K01	2		

INDICE CODICI / DENOMINAZIONI

 CODEX / DESIGNATION INDEX • INDEX CODES / DÉNOMINATIONS
 INHALTSVERZEICHNIS CODE • ÍNDICE CÓDIGOS / DENOMINACIONES

Code	Denominazione	Description	Désignation	Bezeichnung	Descripción	Table	N°
800090375	INTERRUTTORE CAVALLETTO LATERALE	SIDE STAND SWITCH	CONTACTEUR BEQUILLE LATERALE	SCHALTER SEITENSTÄNDER	INTERRUPTOR CABALLETE LATERAL	F03	3
800090380	ANTIVIBRANTE	VIBRATION-DAMPER	ANTI-VIBRATIONS	SCHWINGUNGSDÄMPFER	ANTIVIBRANTE	E05	17
800090391	BUSSOLA	BUSH	BAGUE	HÜLSE	CASQUILLO	B01	16
800090417	FASCETTA IN GOMMA	RUBBER CLAMP	COLLIER EN CAOUTCHOUC	GUMMISCHELLE	CINTA DE GOMA	A01	4
						F04	7
800090419	FLANGIA	FLANGE	FLASQUE	FLANSCH	BRIDA	G16	19
800090429	ANELLO ELASTICO	SNAP RING	CIRCLIP	SPRENGRING	ARO	A02	25
						D01	9
						D02	9
800090890	DADO ELASTICO	SPRING NUT	ECROU AUTOFREINE	ELASTISCHE MUTTER	TUERCA ELASTICA	D03	12
						D04	2
800090897	ANELLO PARAPOLVERE	DUST COVER RING	JOINT-POUSSIÈRE	STAUBSCHUTZRING	ANILLO GUARDAPOLVO	B03	8
800090906	GOMMINO	RUBBER COVER	CAOUTCHOUC	GUMMI	GOMA	B03	18
800090945	ANELLO DI TENUTA	GROMMET	BAGUE D'ÉTANCHEITE	DICHTUNGSRING	RETEN	G08	47
800090978	TAMPONE	PAD	TAMPON	PUFFER	TAPON	E04	4
800090979	TAMPONE	PAD	TAMPON	PUFFER	TAPON	B01	23
800091005	GRAFFETTA	CLIP	AGRAPHE	KLAMMER	GRAPA	E01	4
800091008	DADO ELASTICO M6	M6 SPRING NUT	ECROU AUTOFREINE M6	ELASTISCHE MUTTER M6	TUERCA ELASTICA M6	E03	11
800091022	DADO ELASTICO M4	M4 SPRING NUT	ECROU AUTOFREINE M4	ELASTISCHE MUTTER M4	TUERCA ELASTICA M4	B01	21
						E01	15
						E02	15
						F01	6
						G08	13
						G08	16
800091027	PROTEZIONE	PROTECTION	PROTECTION	ABDECKUNG	PROTECCION	B02	8
800091595	CORNETTO DI ASPIRAZIONE	INTAKE DUCT	CONE D'ADMISSION	ANSAUGSTUTZEN	TUBO DE ASPIRACION	G13	10
800091597	ANELLO DI TENUTA	GROMMET	BAGUE D'ÉTANCHEITE	DICHTUNGSRING	RETEN	G15	14
800091603	ANELLO ELASTICO	SNAP RING	CIRCLIP	SPRENGRING	ARO	G11	8
800091645	CHIAVE GHIERA	STEERING BEARING	CLE A GRIFFES	SCHLÜSSEL GEWINDERING	LLAVE VIROLA		
	CUSCINETTI STERZO	RING NUT WRENCH	ROULEMENTS DIR.	LENKLAGER	COJINETE DIRECCION	J01	2
800091655	PERNO FORCELLONE	FORK PIN	AXE DE BRAS OSCILLANT	SCHWINGENZAPFEN	PERNO HORQUILLA	B01	30
800091688	TUBO SCARICO-SFIATO SERBATOIO	EXHAUST PIPE-FUEL TANK BREATHING PIPE	TUYAU VIDANGE- EVENT RESERVOIR	ABLASS- ENTLÜFTUNGS- LEITUNG BENZINTANK	TUBO DESCARGA RESPIRADERO TANQUE	E04	13
800091689	RACCORDO A Y	WYE	RACCORD EN Y	ZWEIWEGEANSCHLUSS	RACOR A Y	E04	12
800091690	TUBO SCARICO SERBATOIO	FUEL TANK DRAIN PIPE	TUYAU DE VIDANGE RESERVOIR	TANK-ABLASSLEITUNG	TUBO DESCARGA TANQUE	E04	11
800091695	TUBO SFIATO SERBATOIO	FUEL TANK BREATHING PIPE	TUYAU D'EVENT RESERVOIR	TANK-ENTLÜFTUNGSLEITUNG	TUBO RESPIRADERO TANQUE	E04	10
800092247	FASCETTA IN GOMMA	RUBBER CLAMP	COLLIER EN CAOUTCHOUC	GUMMISCHELLE	CINTA DE GOMA	D04	12
						D04	31
						F03	7
						F03	8
						F05	11
800092248	FASCETTA IN GOMMA	RUBBER CLAMP	COLLIER EN CAOUTCHOUC	GUMMISCHELLE	CINTA DE GOMA	D03	36
						D04	30
						F03	9
						F04	4
						F04	5
						F05	13
						G08	63
						G15	15
800092256	FASCETTA CLIC R	CLIC R CLAMP	COLLIER CLIC R	SHELLE CLIC R	ABRAZADERA	G08	52
						G08	72
800092257	TARGHETTA BATTERIA	BATTERY DATA PLATE	PLAQUETTE BATTERIE	BATTERIE-TYPENSCHILD	ETIQUETA BATERIA	A02	2
800092433	SEMICONO PER VALVOLA	COTTERS	DEMI-CLAVETTE DE SOUPAPE	HALBKEGEL FÜR VENTIL	SEMICONO PARA VALVULA	G04	15
800092490	MOLLA	SPRING	RESSORT	FEDER	MUELLE	G11	26

INDICE CODICI / DENOMINAZIONI

CODEX / DESIGNATION INDEX • INDEX CODES / DÉNOMINATIONS

INHALTSVERZEICHNIS CODE • ÍNDICE CÓDIGOS / DENOMINACIONES

Code	Denominazione	Description	Désignation	Bezeichnung	Descripción	Table	N°
800092630	FERMAGLIO PER CAVI	CABLES CLIP	FIXATION POUR CABLES	KLEMMRING FÜR GASZÜGE	CLIP PARA CABLES	D03	10
800092642	CAVALLETTO POSTERIORE	REAR STAND	BEQUILLE ARRIERE	HINTERER STÄNDER	CABALLETE TRASERO	J01	7
800092659	VITE M5X8	SCREW	VIS	SCHRAUBE	TORNILLO	F01	7
800092664	DECAL	DECAL	ADHESIF	AUFKLEBER	CALCOMANIA	E04	1
800092668	FASCETTA IN GOMMA	RUBBER CLAMP	COLLIER EN CAOUTCHOUC	GUMMISCHELLE	CINTA DE GOMA	D02	41
						F03	10
						F04	6
						G08	7
800092857	CHIAVE GHIERA ECCENTRICO STERZO	STEERING ECCENTRIC RING NUT WRENCH	CLE POUR ECROU DECENTRE DIR.	SCHLÜSSEL GEWINDERING LENKEXZENTER	LLAVE VIROLA EXCENTRICO DIRECCION	J01	3
800092860	ESTRATTORE CUSCINETTI FORCELLONE	FORK BEARING EXTRACTOR	EXTRACTEUR	AUSZIEHER	EXTRACTOR	J01	4
800092861	BOCCOLA ESTRATTORE CUSCINETTI	BEARING EXTRACTOR BUSH	DOUILLE	BUCHSE LAGERAUSZIEHER	BUJE EXTRACTOR COJINETES	J01	5
800092865	ATTREZZO BILANCIAMENTO RUOTA POSTERIORE	REAR WHEEL BALANCING TOOL	OUTIL EQUILIBRAGE ROUE ARRIERE	WERKZEUG AUSWUCHTEN HINTERRAD	UTIL BALANCEAMIENTO RUEDA TRASERA	J01	9
800092866	ATTREZZO PACCO FORCELLONE	FORK PACK TOOL	OUTIL PAQUET	WERKZEUG	UTIL PAQUETE HORQUILLA	J01	12
800092867	ATTREZZO PACCO BILANCIERE	EQUALIZER PACK TOOL	OUTIL PAQUET BALANCIER	WERKZEUG	UTIL PAQUETE BALANCIN	J02	1
800092882	ROSETTA	WASHER	RONDELLE	UNTERLEGSCHEIBE	ARANDELA	E01	10
						E04	41
800092890	ECCENTRICO REGOLAZ. PEDANA DX	RH FOOTBOARD ADJUSTMENT ECCENTRIC	EXCENTRIQUE DE REGLAGE CALE-PIED D.	EINSTELLUNGSEXZENTER RECHTE FUSSRASTE	EXCENTRICO REGULACION ESTRIBO DERECHO	D02	3
800092891	ECCENTRICO REGOLAZ. PEDANA SX	LH FOOTBOARD ADJUSTMENT ECCENTRIC	EXCENTRIQUE DE REGLAGE CALE-PIED G.	EINSTELLUNGSEXZENTER LINKE FUSSRASTE	EXCENTRICO REGULACION ESTRIBO IZQUIERDO	D01	3
800093018	FUSIBILE 40A	40A FUSE	FUSIBLE 40A	SICHERUNG 40A	FUSIBLE 40A	F05	4
800093297	VITE M5X8	SCREW	VIS	SCHRAUBE	TORNILLO	D03	6
800093299	PERNO PER LEVA	LEVER PIN	AXE DE LEVIER	HEBELBOLZEN	PERNO PARA PALANCA	D03	20
						D04	14
800093300	DADO PER LEVA	LEVER NUT	ECROU DE LEVIER	MUTTER FÜR HEBEL	TUERCA PARA PALANCA	D03	21
						D04	15
800093302	DIAFRAMMA	DIAPHRAGM	DIAPHRAGME	MEMBRAN	DIAFRAGMA	D03	28
800093303	GUARNIZIONE	GASKET	JOINT	DICHTUNG	EMPAQUE	D03	29
800093306	ANELLO DI TENUTA	GROMMET	BAGUE D'ETANCHEITE	DICHTUNGSRING	RETEN	D03	32
						D04	26
800093307	INTERRUTTORE FRIZIONE	CLUTCH SWITCH	CONTACTEUR EMBRAYAGE	KUPPLUNGSSCHALTER	INTERRUPTOR EMBRAGUE	D04	16
800093311	DIAFRAMMA	DIAPHRAGM	DIAPHRAGME	MEMBRAN	DIAFRAGMA	D04	22
800093312	GUARNIZIONE	GASKET	JOINT	DICHTUNG	EMPAQUE	D04	23
800093313	VITE M4X16	M4X16 SCREW	VIS M4X16	SCHRAUBE M4X16	TORNILLO M4X16	D03	27
						D04	17
						D04	21
800093314	LEVA COMANDO FRENO POSTERIORE	REAR BRAKE LEVER	LEVIER DE COMMANDE FREIN ARRIERE	BREMSPEDALHEBEL HINTERRADBREMSE	PALANCA ACCIONAMIENTO FRENO TRASERO	D02	16
800093347	ASTA SETTAGGIO SOSPENSIONE POST.	REAR SUSPENSION ADJUSTING ROD	TIGE DE REGLAGE SUSPENSION AR.	EINSTELLSTANGE HINTERRADFEDERUNG	VARILLA AJUSTE SUSPENSION TRASERA	J02	12
800093414	PORTADOCUMENTI	DOCUMENT HOLDER	POCHETTE POUR PAPIERS	DOKUMENTENMAPPE	PORTADOCUMENTOS	H01	7
800094019	TARGHETTA "RETROVISORE"	"REARVIEW" MIRROR DATA PLATE	PLAQUETTE "RETROVISEUR"	SCHILD "RÜCKSPIEGEL"	ETIQUETA "RETROVISORES"	K01	4
800094030	PROTEZIONE FERMAGLIO	CLIP PROTECTION	PROTECTION	KLEMMRINGSICHERUNG	PROTECCION CLIP	C01	36
800094170	MOLLA	SPRING	RESSORT	FEDER	MUELLE	A02	27
800094171	BUSSOLA ROTAZIONE PEDANA POSTERIORE	REAR FOOTBOARD SWING BUSH	BAGUE ROTATION CALE-PIED ARRIERE	DREHBUCHSE HINTERE FUSSRASTE	CASQUILLO ROTACION ESTRIBO TRASERO	A02	23
800094279	RIVETTO	RIVET	RIVET	NIETE	REMACHE	A02	6
800094626	ANELLO DI TENUTA	GROMMET	BAGUE D'ETANCHEITE	DICHTUNGSRING	RETEN	G01	41
800094643	ANELLO ELASTICO	SNAP RING	CIRCLIP	SPRENGRING	ARO	D03	34
						D04	28

INDICE CODICI / DENOMINAZIONI

 CODEX / DESIGNATION INDEX • INDEX CODES / DÉNOMINATIONS
 INHALTSVERZEICHNIS CODE • ÍNDICE CÓDIGOS / DENOMINACIONES

Code	Denominazione	Description	Désignation	Bezeichnung	Descripción	Table	N°
800094796	ATTREZZO MONTA/ SMONTA VALVOLE	VALVES ASSEMBLY/ DISASSEMBLY TOOL	OUTIL LEVE-SOUPAPE	WERKZEUG ZUM EIN-/ AUSBAU VENTILE	UTIL MONTAJE DESMONTAJE VALVULA	J03	14
800094797	LASTRA SAGOMATA COPRI TESTA	HEAD COVER SHAPED PLATE	PLAQUE COUVRE-CULASSE	ABDECKSCHABLONE L ZYLINDERKOPF	AMINA PERFILADA CUBRE CULATA	J03	8
800094798	ATTREZZO GOMMINI VALVOLA	VALVE RUBBER RINGS TOOL	OUTIL CAOUTCHOUC SOUPAPE	WERKZEUG VENTILGUMMI	UTIL CAUCHOS VALVULA	J03	11
800095179	ATTREZZO SMONTAGGIO SEMICONI	HALF-CONES DISASSEMBLING TOOL	OUTIL POUR LE DÉMONTAGE DES MOITIÉ-CÔNES	WERKZEUG FÜR DAS HÄLFTE- KEGELAUSEINANDERBAUEN	UTIL PARA EL DESMONTAJE DE LOS MITAD-CONOS	J03	20
800095180	ATTREZZO MONTAGGIO SEMICONI	HALF-CONES ASSEMBLING TOOL	OUTIL POUR LE MONTAGE DES MOITIE-CONES	WERKZEUG FÜR DAS HÄLFTE- KEGELZUSAMMENBAUEN	UTIL PARA EL MONTAJE DE LOS MITAD-CONOS	J03	21
800095318	TAMPONE PER SEDE VALVOLA SCARICO	PAD FOR EXHAUST VALVE SEAT	TAMPON POUR LE SIEGE DE SOUPAPE D'ÉCHAPPEMENT	AUFLAGE FÜR AUSLASSVENTILSITZ	COJIN PARA EL ASIENTO DE LA VALVULA DE ESCAPE	J04	5
800095319	TAMPONE PER SEDE VALVOLA ASPIRAZIONE	PAD FOR INTAKE VALVE SEAT	TAMPON POUR LE SIÈGE DE SOUPAPE D'ADMISSION	AUFLAGE FÜR EINLASSVENTILSITZ	COJÍN PARA EL ASIENTO DE LA VALVULA DE ADMISION	J04	6
800095366	TARGHETTA BENZINA	FUEL DATA PLATE	PLAQUETTE ESSENCE	SCHILD BENZIN	ETIQUETA GASOLINA	K01	3
800095429	TAMPONE CONTROLLO	CONTROL PAD	TAMPON CONTROLE	KONTROLLPUFFER	TAPON CONTROL	J03	16
800095505	ROSETTA	WASHER	RONDELLE	UNTERLEGSCHLEIBE	ARANDELA	G06	15
800095581	PUNZONE MONTAGGIO TENUITE VALVOLA	VALVE SEAL ASSEMBLY TOOL	POUSSOIR MONTAGE JOINTS SOUPAPES	SCHLAGDORN VENTILDICHTUNGEN	MONTAGE PUNZON MONTAJE ESTANQUEIDAD VALVULA	J03	17
800095807	CAVALLETTO ANTERIORE	FRONT STAND	BEQUILLE AVANT	VORDERER STÄNDER	CABALLETE DELANTERO	J02	6
800095808	PERNO CAVALLETTO ANTERIORE	FRONT STAND PIN	AXE BEQUILLE AVANT	VORDERER STÄNDERBOLZEN	PERNO CABALLETE DELANTERO	J02	7
800095828	ANTIVIBRANTE	VIBRATION-DAMPER	ANTI-VIBRATIONS	SCHWINGUNGSDÄMPFER	ANTIVIBRANTE	A02 G13	31 28
800092642	CAVALLETTO ANTERIORE	FRONT STAND	BEQUILLE AVANT	VORDERER STÄNDER	CABALLETE DELANTERO	J01	1
800095842	TARGHETTA MARCE	GEARS DATA PLATE	PLAQUETTE VITESSES	SCHILD GÄNGE	ETIQUETA MARCHAS	K01	5
800095850	PINZA MONTA/SMONTA FASCETTE CLIC	CLIC CLAMPS ASSEMBLY/ DISASSEMBLY PLIERS	PINCE POUR COLLIERS CLIC	ZANGE EIN-/ AUSBAU SCHELLEN CLIC	PINZA MONTAJE/ DESMONTAJE ABRAZADERAS	J01	10
800095906	CANDELA NGK CR9EB	NGK CR9EB SPARK PLUG	BOUGIE NGK CR9EB	ZÜNDKERZE NGK CR9EB	BUJIA NGK CR9EB	G15	7
800096458	FASCETTA CLIC	CLIC CLAMP	COLLIER CLIC	SCHELLE CLIC	ABRAZADERA CLIC	G13 G13 K02 K02	4 13 13 15
800096747	TAPPO	PLUG	BOUCHON	VERSCHLUSS	TAPON	G01	58
800097083	CANISTER	CARBON CANISTER	CANISTER	CARBONKANISTER	CANISTER	K02	1
800097088	RACCORDO A 5 VIE	5-WAY FITTING	RACCORD A 5 DIRECTIONS	5-WEISE ANSCHLUSS	RACOR A 5 VIAS	K02	20
800097089	TUBO IN GOMMA	HOSE	DURIT	GUMMISCHLAUCH	TUBO DE GOMA	K02	5
800097090	TUBO IN GOMMA	HOSE	DURIT	GUMMISCHLAUCH	TUBO DE GOMA	K02	21
800097121	SERBATOIO OLIO FRENO ANTERIORE	FRONT BRAKE FLUID SUPPLY TANK	RESERVOIR DE LIQUIDE FREIN AVANT	BREMFLÜSSIGKEITSBEHÄLTER VORDERRADBREMSE	DEPOSITO ACEITE FRENO DELANTERO	D03	25
800097122	SERBATOIO OLIO POMPA FRIZIONE	CLUTCH PUMP OIL TANK	RESERV. FLUIDE MAITRE- CYLINDRE EMBRAYAGE	KUPPLUNGSFÜSSIGKEITS- BEHÄLTER	DEPOSITO ACEITE BOMBA EMBRAGUE	D04	19
800097784	VITE M10X25	M10X25 SCREW	VIS M10X25	SCHRAUBE M10X25	TORNILLO M10X25	B04 B05 B06 B07	1 1 1 1
800097867	SUPPORTO MOTORE	ENGINE MOUNTING	SUPPORT MOTEUR	MOTORHALTER	SOPORTE MOTOR	J03	19
800097884	GRAFFETTA	CLIP	AGRAPHE	KLAMMER	GRAPA	G08	44
800097887	ATTREZZO CUSCINETTO PERNO STERZO	STEERING PIN BEARING TOOL	OUTIL ROULEMENT DIRECTION	WERKZEUG UTIL LENKLAGERZAPFEN	COJINETE PERNO DIRECCION	J02	8
800097888	PIASTRA DI RISCONTRO BASE DI STERZO	STEERING BASE CONTROL PLATE	PLAQUE D'APPUI TE INFERIEUR	AUFLAGEPLATTE LENKBASIS	PLACA DE CONTACTO BASE DIRECCION	J02	9
800097889	ESTRATTORE CUSCINETTO STERZO	STEERING BEARING EXTRACTOR	EXTRACTEUR ROULEMENT DIRECTION	AUSZIEHER LENKLAGER	EXTRACTOR COJINETE DIRECCION	J02	10
800097890	ATTREZZO MONTAGGIO CUSCINETTO STERZO	STEERING BEARING ASSEMBLY TOOL	OUTIL MONT. ROULEMENT DIRECTION	WERKZEUG MONTAGE LENKLAGER	UTIL MONTAJE COJINETE DIRECCION	J02	11
800097910	GUARNIZIONE	GASKET	JOINT	DICHTUNG	EMPAQUE	E03	13



INDICE CODICI / DENOMINAZIONI
CODEX / DESIGNATION INDEX • INDEX CODES / DÉNOMINATIONS
INHALTSVERZEICHNIS CODE • ÍNDICE CÓDIGOS / DENOMINACIONES

Code	Denominazione	Description	Désignation	Bezeichnung	Descripción	Table	N°
800098321	PINZA INCLINATA MONTA FASCETTE CLIC	CLIC CLAMPS ASSEMBLY	PLIERS PINCE INCLINEE MONTAGE COLLIERS CLIC	GEBOGENE ZANGE SCHELLEN CLIC	MONTAGE PINZA INCLINADA PARA MONTAR ABRAZADERAS	J01	11
800098405	CUSCINETTO	BEARING	ROULEMENT	LAGER	COJINETE	J03	4
800098670	MOLLA ESTERNA VALVOLA	VALVE OUTER SPRING	RESSORT EXTERIEUR SOUPAPE	ÄUSSERE VENTILFEDER	MUELLE EXTERNO VALVULA	G04	11
800098671	MOLLA INTERNA VALVOLA	VALVE INNER SPRING	RESSORT INTERIEUR SOUPAPE	INNERE VENTILFEDER	MUELLE INTERNO VALVULA	G04	12
800098715	TUBO IN GOMMA	HOSE	DURIT	GUMMISCHLAUCH	TUBO DE GOMA	K02	18
800098716	PROTEZIONE RADIATORE ACQUA	WATER COOLER PROTECTION	PROTECTION DE RADIATEUR D'EAU	KÜHLER ABDECKUNG	PROTECCION RADIADOR AGUA	G08	11
800098832	DECAL	DECAL	ADHESIF	AUFKLEBER	CALCOMANIA	E04	7
800098846	GUARNIZIONE	GASKET	JOINT	DICHTUNG	EMPAQUE	F01	21
800098847	GUARNIZIONE	GASKET	JOINT	DICHTUNG	EMPAQUE	F01	19
800098873	TUBO SFIATO VAPORI OLIO	OIL VAPORS BREATHER PIPE	TUYAU D'EVENT VAPEURS D'HUILE	ÖLDAMPF- ENTLÜFTUNGSLEITUNG	TUBO RESPIRADERO VAPORES DE ACEITE	E03	12
800098950	TUBO SCARICO SERBATOIO	FUEL TANK DRAIN PIPE	TUYAU DE VIDANGE RESERVOIR	TANK-ABLASSLEITUNG	TUBO DESCARGA TANQUE	K02	17
800098962	SEPARATORE	SEPARATOR	SEPARATEUR	TRENNVORRICHTUNG	SEPARADOR	D03 D04	30 24
800099114	AVVISATORE ACUSTICO	WARNING HOOTER	AVERTISSEUR SONORE	HUPE	CLAXON	F01	11
800099149	ANTIVIBRANTE	VIBRATION-DAMPER	ANTI-VIBRATIONS	SCHWINGUNGSDÄMPFER	ANTIVIBRANTE	A02	12
800099249	ANTIVIBRANTE	VIBRATION-DAMPER	ANTI-VIBRATIONS	SCHWINGUNGSDÄMPFER	ANTIVIBRANTE	G08	12
800099278	ROSETTA	WASHER	RONDELLE	UNTERLEGSCHEIBE	ARANDELA	G08	17
800099293	RETINA	NET	GRILLE	GITTERNETZ	REDECILLA	G08	35
800099322	TAMPONE	PAD	TAMPON	PUFFER	TAPON	G08	36
800099326	ANTIVIBRANTE	VIBRATION-DAMPER	ANTI-VIBRATIONS	SCHWINGUNGSDÄMPFER	ANTIVIBRANTE	E04	29
800099336	MOLLETTA DX PER AIRBOX	RH SPRING FOR AIRBOX	PINCE D. POUR AIRBOX	RECHTE KLAMMER FÜR AIRBOX	NUELE DER. PARA AIRBOX	E03	17
800099337	MOLLETTA SX PER AIRBOX	LH SPRING FOR AIRBOX	PINCE G. POUR AIRBOX	LINKE KLAMMER FÜR AIRBOX	NUELE IZQ. PARA AIRBOX	E03	4
800099349	PROTEZIONE SUPERIORE	UPPER PROTECTION	PROTECTION SUPERIEUR	OBERE ABDECKUNG	PROTECCION SUPERIOR	G16	10
800099383	GUARNIZIONE SCARICO	EXHAUST GASKET	JOINT D'ECHAPPEMENT	AUSPUFFDICHTUNG	EMPAQUE ESCAPE	G16	1
800099391	GUIDA CAVI	CABLES GUIDE	GUIDE DES CABLES	KABELFÜHRUNG	GUIAS DE CABLES	F06	10
800099401	BUSSOLA	BUSH	BAGUE	HÜLSE	CASQUILLO	E04	24
800099403	PROTEZIONE INFERIORE	LOWER PROTECTION	PROTECTION INFERIEUR	UNTERE ABDECKUNG	PROTECCION INFERIOR	G16	8
800099419	ANTIVIBRANTE	VIBRATION-DAMPER	ANTI-VIBRATIONS	SCHWINGUNGSDÄMPFER	ANTIVIBRANTE	A01 F03	35 15
800099426	CAPPUCCIO	CAP	CAPUCHON	KAPPE	CAPUCHON	A01 G08	23 74
8000A0370	BUSSOLA	BUSH	BAGUE	HÜLSE	CASQUILLO	G10 G10 G10 G10 G10	5 10 17 22 27
8000A0515	GOMMINO	RUBBER COVER	CAOUTCHOUC	GUMMI	GOMA	G15	13
8000A0606	SPINOTTO	PISTON PIN	AXE DE PISTON	KOLBENBOLZEN	PERNO DEL PISTON	G03	4
8000A0730	MOLLA	SPRING	RESSORT	FEDER	MUELLE	G17	10
8000A0817	ANELLO DI TENUTA	GROMMET	BAGUE D'ETANCHEITE	DICHTUNGSRING	RETEN	B04 B05 B06 B07	24 24 23 23
8000A0901	ROSETTA	WASHER	RONDELLE	UNTERLEGSCHEIBE	ARANDELA	G11	13
8000A0903	TAMPONE PER SERBATOIO	FUEL TANK PAD	TAMPON DE RESERVOIR	BENZINTANKPUFFER	TAPON DEPOSITO GASOLINA	E04	33
8000A0922	COMMUTATORE SX	LH SWITCH	COMODO G.	LINKER WECHSELSCHALTER	CONMUTADOR IZQUIERDO	D04	6
8000A0973	ROSETTA	WASHER	RONDELLE	UNTERLEGSCHEIBE	ARANDELA	G10 G10	4 9
8000A0975	ANELLO ELASTICO	SNAP RING	CIRCLIP	SPRENGRING	ARO	G10	7
8000A0987	ROSETTA	WASHER	RONDELLE	UNTERLEGSCHEIBE	ARANDELA	G10	26
8000A0990	ANELLO ELASTICO	SNAP RING	CIRCLIP	SPRENGRING	ARO	G10	20
8000A1039	ATTREZZO PARAPOLVERE E PARAOLIO	DUST COVER AND OIL SEAL TOOL	OUTIL JOINT-POUSSIÈRE ET JOINT A LEVRE	WERKZEUG STAUBSCHUTZRINGE UND ÖLDICHTRINGE	UTIL GUARDAPOLVO Y RETEN DE ACEITE	J01	13

INDICE CODICI / DENOMINAZIONI

 CODEX / DESIGNATION INDEX • INDEX CODES / DÉNOMINATIONS
 INHALTSVERZEICHNIS CODE • ÍNDICE CÓDIGOS / DENOMINACIONES

Code	Denominazione	Description	Désignation	Bezeichnung	Descripción	Table	N°
8000A1086	CUSCINETTO	BEARING	ROULEMENT	LAGER	COJINETE	G11	4
8000A1087	CUSCINETTO	BEARING	ROULEMENT	LAGER	COJINETE	G01 J03	25 3
8000A1234	ROSETTA	WASHER	RONDELLE	UNTERLEGSCHIEBE	ARANDELA	G10	31
8000A1239	MOLLA	SPRING	RESSORT	FEDER	MUELLE	G16	6
8000A1295	VITE PER SEPARATORE	SEPARATOR SCREW	VIS DE SEPARATEUR	SCHRAUBE FÜR TRENNVORRICHTUNG	TORNILLO PARA SEPARADOR	D03 D04	31 25
8000A1402	CONTRAPPESO	COUNTERWEIGHT	CONTREPOIDS	GEGENGEWICHT	CONTRAPESO	D03 D04	11 1
8000A1409	GUIDA TRASMISSIONE GAS	THROTTLE TRANSMISSION GUIDE	GUIDE TRANSMISSION DES GAZ	GASZUG FÜHRUNG	GUIAS TRANSMISION GAS	G08	15
8000A1792	FASCETTA METALLICA	METAL CLAMP	COLLIER METALLIQUE	METALLSCHELLE	CINTA METALICA	F03	24
8000A1860	BOCCOLA	BUSH	DOUILLE	BUCHSE	CASQUILLO	B04 B05 B06 B07	5 5 5 5
8000A1863	PARAPOLVERE	DUST COVER	JOINT-POUSSIÈRE	STAUBSCHUTZRING	GUARDAPOLVO	B04 B05 B06 B07	13 13 16 16
8000A1867	ROSETTA	WASHER	RONDELLE	UNTERLEGSCHIEBE	ARANDELA	B04 B05 B06 B07	16 16 19 19
8000A1868	DISTANZIALE	SPACER	ENTRETOISE	ABSTANDHALTER	DISTANCIADOR	B04 B05 B06 B07	17 17 20 20
8000A1870	ANELLO DI TENUTA	GROMMET	BAGUE D'ÉTANCHEITE	DICHTUNGSRING	RETEN	B04 B05 B06 B07	19 19 22 22
8000A1873	BUSSOLA	BUSH	BAGUE	HÜLSE	CASQUILLO	F06	6
8000A1938	GUARNIZIONE	GASKET	JOINT	DICHTUNG	EMPAQUE	G04	25
8000A1939	GUARNIZIONE	GASKET	JOINT	DICHTUNG	EMPAQUE	G04	26
8000A1953	PERNO PER ALBERO DI CENTRAGGIO	PIN FOR CENTERING SHAFT	AXE POUR ARBRE DE CENTRAGE	BOLZEN FÜR ZENTRIERWELLE	PERNO PARA EJE DE CENTRAJE	J01	8
8000A1956	INGRANAGGIO 6°	6TH GEAR	PIGNON 6°	ZAHNRAD 6. GANG	ENGRANAJE 6°	G10	11
8000A1957	INGRANAGGIO 6°	6TH GEAR	PIGNON 6°	ZAHNRAD 6. GANG	ENGRANAJE 6°	G10	21
8000A2041	VITE PER SPURGO	DRAIN SCREW	VIS DE PURGE	ENTLÜFTUNGSSCHRAUBE	ESPURGO	C03	17
8000A2042	PARAPOLVERE	DUST COVER	JOINT-POUSSIÈRE	STAUBSCHUTZRING	GUARDAPOLVO	C03	13
8000A2126	INGRANAGGIO RUOTA LIBERA	FREEWHEEL GEAR	PIGNON ROUE LIBRE	ZAHNRAD FREILAUF	ENGRANAJE RUEDA LIBRE	G14	7
8000A2131	PERNO	PIN	AXE	ZAPPEN	PERNO	G14	19
8000A2139	PIASTRINA	PLATE	PLAQUETTE	BLECH	PLACA	G14	20
8000A2140	INGRANAGGIO INTERMEDIO	IDLER GEAR	PIGNON INTERMEDIAIRE	ZWISCHEN-ZAHNRAD	ENGRANAJE INTERMEDIO	G14	22
8000A2170	PRIGIONIERO	STUD BOLT	GOUJON	STIFTSCHRAUBE	ESPARRAGO	G01	23
8000A2171	PRIGIONIERO	STUD BOLT	GOUJON	STIFTSCHRAUBE	ESPARRAGO	G01	24
8000A2180	ANELLO DI TENUTA	GROMMET	BAGUE D'ÉTANCHEITE	DICHTUNGSRING	RETEN	D03	38
8000A2181	ANELLO DI TENUTA	GROMMET	BAGUE D'ÉTANCHEITE	DICHTUNGSRING	RETEN	D03	37
8000A2270	LAMELLA ARIA SECONDARIA	SECONDARY AIR BLADE	LAME D'AIR SECONDAIRE	SEKUNDÄRLUFT-BLATT	LÁMINA DEL AIRE SECUNDARIO	G04	22
8000A2280	ATTREZZO CHIUSURA CATENA DISTRIBUZIONE	TIMING CHAIN MOUNTING TOOL	OUTIL MONTAJE CHAÎNE DISTRIBUTION	WERKZEUG VENTIL- STEUERKETTENBAU	UTIL MONTAJE CADENA DE LA DISTRIBUCION	J04	3
8000A2281	ATTREZZO APERTURA CATENA DISTRIBUZIONE	TIMING CHAIN CUTTING TOOL	OUTIL COUPE CHAÎNE DISTRIBUTION	WERKZEUG VENTIL- STEUERKETTENSCHNITT	UTIL CORTE CADENA DE LA DISTRIBUCION	J04	4
8000A2318	CUSCINETTO	BEARING	ROULEMENT	LAGER	COJINETE	G11	3



INDICE CODICI / DENOMINAZIONI
CODEX / DESIGNATION INDEX • INDEX CODES / DÉNOMINATIONS
INHALTSVERZEICHNIS CODE • ÍNDICE CÓDIGOS / DENOMINACIONES

Code	Denominazione	Description	Désignation	Bezeichnung	Descripción	Table	N°
8000A2385	TAMPONE MONTAGGIO GUIDA	GUIDE ASSEMBLY PAD	TAMPON MONTAGE GUIDE	PUFFER MONTAGE FÜHRUNG	TAPON MONTAJE GUIAS	J03	18
8000A2537	FORCELLA INNESTO MARCE	SHIFTING FORK	FOURCHETTE DE SELECTION	SCHALTGABEL	HORQUILLA ENGRANE MARCHA	G11	16
8000A2553	CUSCINETTO	BEARING	ROULEMENT	LAGER	COJINETE	G09	24
						G17	24
8000A2554	ROSETTA	WASHER	RONDELLE	UNTERLEGSCHIEBE	ARANDELA	G09	21
						G17	21
8000A2555	ROSETTA	WASHER	RONDELLE	UNTERLEGSCHIEBE	ARANDELA	G09	22
						G17	22
8000A2556	DISTANZIALE	SPACER	ENTRETOISE	ABSTANDHALTER	DISTANCIADOR	G09	23
						G17	23
8000A2565	CUSCINETTO	BEARING	ROULEMENT	LAGER	COJINETE	G09	7
						G17	9
8000A2566	PERNO COMANDO FRIZIONE	CLUTCH CONTROL PIN	POUSSOIR DE DEBRAYAGE	KUPPLUNGZAPFEN	PERNO ACCIONAMIENTO		
					EMBRAGUE	G09	15
8000A2625	BROCCIA PER GUIDA VALVOLE	BROACH FOR VALVE GUIDE	BROCHE POUR GUIDE	VENTILFÜHRUNGSRÄUMEN	MANDRIL PARA GUIA VALVOLA		
			DE SOUPE			J03	22
8000A2630	INGRANAGGIO 5°	5TH GEAR	PIGNON 5°	ZAHNRAD 5. GANG	ENGRANAJE 5°	G10	6
8000A2631	INGRANAGGIO 3°-4°	3RD-4TH GEAR	PIGNON 3°-4°	ZAHNRAD 3. GANG-4. GANG	ENGRANAJE 3°-4°	G10	8
8000A2637	INGRANAGGIO 3°	3RD GEAR	PIGNON 3°	ZAHNRAD 3. GANG	ENGRANAJE 3°	G10	23
8000A2638	INGRANAGGIO 4°	4TH GEAR	PIGNON 4°	ZAHNRAD 4. GANG	ENGRANAJE 4°	G10	24
8000A2640	INGRANAGGIO 1°	1ST GEAR	PIGNON 1°	ZAHNRAD 1. GANG	ENGRANAJE 1°	G10	28
8000A2643	ALBERO PRIMARIO	MAIN SHAFT	ARBRE PRIMAIRE	HAUPTANTRIEBSWELLE	ARBOL PRIMARIO	G10	1
8000A2644	ALBERO PRIMARIO COMPLETO	MAIN SHAFT ASSEMBLY	ARBRE PRIMAIRE COMPLET	HAUPTANTRIEBSWELLE KOMPL.	ARBOL PRIMARIO COMPLETO	G10	2
8000A2645	INGRANAGGIO 2°	2ND GEAR	PIGNON 2°	ZAHNRAD 2. GANG	ENGRANAJE 2°	G10	12
8000A2650	INGRANAGGIO 2°	2ND GEAR	PIGNON 2°	ZAHNRAD 2. GANG	ENGRANAJE 2°	G10	18
8000A2714	ANELLO ELASTICO	SNAP RING	CIRCLIP	SPRENGRING	ARO	G03	5
8000A2734	DECAL	DECAL	ADHESIF	AUFKLEBER	CALCOMANIA	B01	27
8000A3026	BIELLA COMPLETA	CONNECTING ROD ASSEMBLY	BIELLE COMPLETE	PLEUEL KOMPLETT	BIELA COMPLETA	G02	3
8000A3406	ATTREZZO MISURA	PISTON PROJECTION	OUTIL MASURE	WERKZEUG ZUM MESSEN	UTIL PARA MEDIR		
	SPORGENZA PISTONI	MEASURING TOOL	DEPASSEMENT PISTONS	KOLBENÜBERSTAND	SOBRESALIDA DEL PISTON	J03	7
8000A3478	BICCHIERINO PER VALVOLA	VALVE CUP	GODET POUR SOUPE	VENTILBECHER	TAZA PARA VALVULA	G05	9
8000A3486	ROSETTA	WASHER	RONDELLE	UNTERLEGSCHIEBE	ARANDELA	G05	13
8000A3709	PORTATUBO	PIPE CARRIER	PORTE-CANALISATION	LEITUNGSHALTERUNG	PORTATUBO	E03	18
8000A3732	SCODELLINO SUPERIORE	UPPER CAP	COUPELLE SUPERIEURE	OBERER FEDERTELLER	TEJUELO SUPERIOR	G04	13
8000A3733	PIATTELLO INFERIORE	LOWER CAP	COUPELLE INFERIEURE	UNTERER FEDERTELLER	ASIENTO INFERIOR	G04	14
8000A3822	DADO M12	M12 SPRING	ECROU M12	MUTTER M12	TUERCA M12	E03	16
8000A3827	ROSETTA	WASHER	RONDELLE	UNTERLEGSCHIEBE	ARANDELA	E03	20
8000A3975	SPURGO	DRAIN VALVE	VIS DE PURGE	ENTLÜFTUNGSSCHRAUBE	ESPURGO	C02	13
8000A4000	TARGHETTA PNEUMATICI	TYRES DATA PLATE	PLAQUETTE PNEUMATIQUES	SCHILD REIFEN	ETIQUETA NEUMATICOS	A01	34
8000A4009	DISTANZIALE	SPACER	ENTRETOISE	ABSTANDHALTER	DISTANCIADOR	G13	30
8000A4196	ROSETTA	WASHER	RONDELLE	UNTERLEGSCHIEBE	ARANDELA	G10	19
8000A4317	ATTREZZO PER FILTRO OLIO	OIL FILTER TOOL	OUTIL POUR FILTRE A HUILE	WERKZEUG FÜR ÖLFILTER	UTIL PARA FILTRO ACEITE	J04	1
8000A4426	ANTIVIBRANTE	VIBRATION-DAMPER	ANTI-VIBRATIONS	SCHWINGUNGSDÄMPFER	ANTIVIBRANTE	D03	32
						D03	40
8000A4492	BUSSOLA	BUSH	BAGUE	HÜLSE	CASQUILLO	G09	10
						G17	11
8000A4539	TAPPO	PLUG	BOUCHON	VERSCHLUSS	TAPON	B01	18
8000A4690	PARAPOLVERE	DUST COVER	JOINT-POUSSIÈRE	STAUBSCHUTZRING	GUARDAPOLVO	B04	6
						B05	6
						B06	6
						B07	6
8000A4780	ROSETTA	WASHER	RONDELLE	UNTERLEGSCHIEBE	ARANDELA	G10	29
8000A5200	GUARNIZIONE TESTA (SP. 0.40)	HEAD GASKET (THICKNESS 0.40)	JOINT DE CULASSE (EP. 0.40)	ZYLINDERKOPFDICHTUNG (STÄRKE 0.40)	JUNTA CULATA (SP. 0.40)	G03	9
8000A5235	VITE FISSAGGIO BIELLA	CONNECTING ROD CLAMP SCREW	VIS DE FIXATION	BIELLE PLEUEL BEFESTIGUNGSSCHRAUBE	TORNILLO FIJACION BIELA	G02	4

INDICE CODICI / DENOMINAZIONI

 CODEX / DESIGNATION INDEX • INDEX CODES / DÉNOMINATIONS
 INHALTSVERZEICHNIS CODE • ÍNDICE CÓDIGOS / DENOMINACIONES

Code	Denominazione	Description	Désignation	Bezeichnung	Descripción	Table	N°
8000A5239	DECAL	DECAL	ADHESIF	AUFKLEBER	CALCOMANIA	E01	21
8000A5282	CORNETTO DI ASPIRAZIONE	INTAKE DUCT	CONE D'ADMISSION	ANSAUGSTUTZEN	TUBO DE ASPIRACION	G13	10
8000A5350	TELERUTTORE AVVIAMENTO	SOLENOID STARTER	TELERUPTEUR DU DEMARREUR	ANLASSER FERNRELAIS	TELERRUPTOR DE ARRANQUE	F05	3
8000A5393	CAVO INTERFACCIA	INTERFACE CABLE	CABLE D'INTERFACE	INTERFACE KABEL	CABLE DE INTERFAZ	J03	24
8000A6388	COMMUTATORE DX	RH SWITCH	COMODO D.	RECHTER WECHSELSCHALTER	COMUTADOR DER.	D03	16
8000A6408	SENSORE DI CADUTA	FALL SENSOR	SONDE DE CHUTE	FALL-SENSOR	SENSOR DE LA CAÍDA	F03	1
8000A6700	BOBINA COMPLETA	IGNITION COIL ASSEMBLY	BOBINE D'ALLUMAGE COMPLETE	ZÜNDSPULEN KOMPLETT	BOBINA COMPLETA	G15	12
8000A6749	RELÉ	RELAY	RELAIS	RELAIS	RELÉ	F05	16
8000A6914	MOZZO PORTADISCHI	DISK HUB	NOIX D'EMBRAYAGE	KUPPLUNGSSCHEIBENNABE	CUBO PORTADISCOS	G09	1
8000A6915	DISCO FRIZIONE GUARNITO	LINED CLUTCH DISK	DISQUE GARNI	KUPPLUNGSSCHEIBE MIT BELAG	DISCO EMBRAGUE CON JUNTA	G09	2
						G17	4
8000A6916	DISCO FRIZIONE GUARNITO	LINED CLUTCH DISK	DISQUE GARNI	KUPPLUNGSSCHEIBE MIT BELAG	DISCO EMBRAGUE CON JUNTA	G09	3
						G17	5
8000A6917	DISCO FRIZIONE GUARNITO	LINED CLUTCH DISK	DISQUE GARNI	KUPPLUNGSSCHEIBE MIT BELAG	DISCO EMBRAGUE CON JUNTA	G09	4
						G17	6
8000A6918	DISCO CONDOTTO LISCIO	PLAIN DRIVEN PLATE	DISQUE LISSE GLATTE	GEFÜHRTE SCHEIBE	DISCO CONDUCCIDO LISO	G09	5
						G17	7
8000A6919	PIATTO SPINGIDISCHI	DISK THRUST PLATE	PLATEAU DE PRESSION	DRUCKTELLER	PLATO DE PRESION	G09	6
8000A6921	MOLLA	SPRING	RESSORT	FEDER	MUELLE	G09	8
8000A6922	MOLLA	SPRING	RESSORT	FEDER	MUELLE	G09	11
						G17	18
8000A6923	SUPPORTO MOLLA	SPRING SUPPORT	SUPPORT DU RESSORT	FEDERHALTERUNG	SOPORTE MUELLE	G09	12
						G17	19
8000A7379	INGRANAGGIO (SCARICO)	GEAR (EXHAUST)	PIGNON (ECHAPPEMENT)	ZAHNRAD (AUSLASS)	ENGRANAJE (ESCAPE)	G05	11
8000A7390	DADO	SPRING	ECROU	MUTTER	TUERCA	G14	16
8000A7505	ELETTRVENTOLA	HEATER FAN	ELECTROVENTILATEUR	KÜHLGEBLÄSE	ELECTROVENTILADOR	G08	1
8000A7507	TUBO TERMOSTATO/ RADIATORE	THERMOSTAT/ RADIATOR PIPE	CANALISATION THERMOSTAT/ RADIATEUR	LEITUNG THERMOSTAT/ KÜHLER	TUBO TERMOSTATO/ RADIADOR	G08	64
8000A7688	CHIAVE USB VDST PRO	USB KEY VDST PRO	CLÉ USB VDST PRO	USB SCHLÜSSEL VDST PRO	LLAVE USB VDST PRO	J03	23
8000A7689	ADATTATORE USB/SERIALE	SERIAL/USB ADAPTER	ADAPTATEUR USB/SERIALE	ADAPER USB/SERIELL	ADAPTADOR USB/SERIAL	J03	26
8000A7862	INTERRUTTORE MINIMA PRESSIONE OLIO	OIL MIN. PRESSURE SENSOR	MANOCONTACT PRESSION . HUILE MIN	ÖLDRUCKSCHALTER	INTERRUPTOR MINIMA PRESION ACEITE	G15	1
8000A8182	DADO FISSAGGIO TESTA	HEAD STOP NUT	ECROU DE FIXATION CULASSE	MUTTER ZYLINDERKOPFBEFESTIGUNG	TUERCA FIJACION CULATA	G04	18
8000A8286	DECAL	DECAL	ADHESIF	AUFKLEBER	CALCOMANIA	B04	26
						B05	26
						B06	13
						B07	13
8000A8326	PIASTRINA	PLATE	PLAQUETTE	BLECH	PLACA	G04	30
8000A8617	KIT MANTENIMENTO CARICA BATTERIA	BATTERY CHARGE MAINTENANCE KIT	KIT DE MAINTENANCE DE CHARGE DE BATTERIE	WARTUNGSBAUSATZ DER BATTERIELADUNG	KIT DE MANTENIMIENTO DE CARGA DE BATERÍA	H01	10
8000A8618	CAVO MANTENIMENTO CARICA BATTERIA	BATTERY CHARGE MAINTENANCE CABLE	CABLE DE MAINTENANCE DE CHARGE DE BATTERIE	WARTUNGSKABEL DER BATTERIELADUNG	CABLE DE MANTENIMIENTO DE CARGA DE BATERÍA	H01	11
8000A8968	SONDA LAMBDA	LAMBDA SENSOR	SONDE LAMBDA	LAMBDA-SONDE	SONDA LAMBDA	G16	26
8000A8989	TAPPO	PLUG	BOUCHON	VERSCHLUSS	TAPON	G04	28
8000A9043	VALVOLA ARIA SECONDARIA	SECONDARY AIR VALVE	SOUPAPE DE L'AIR SECONDAIRE	SEKUNDÄRLUFTVENTIL	VALVULA AIRE SECUNDARIO	G13	32
8000A9044	TUBO VALVOLA ARIA SECONDARIA	SECONDARY AIR VALVE PIPE	TUYAU DU SOUPAPE DE L'AIR SECONDAIRE	SEKUNDÄRLUFTVENTIL- LEITUNG	TUBO VALVULA DEL AIRE SECUNDARIO	G13	21
8000A9045	TUBO VALVOLA ARIA SECONDARIA	SECONDARY AIR VALVE PIPE	TUYAU DU SOUPAPE DE L'AIR SECONDAIRE	SEKUNDÄRLUFTVENTIL- LEITUNG	TUBO VALVULA DEL AIRE SECUNDARIO	G13	24
8000A9050	FILTRO ARIA	AIR FILTER	FILTRE A AIR	LUFTFILTER	FILTRO AIRE	E03	14
8000A9370	GUARNIZIONE TESTA (SP. 0.40)	HEAD GASKET (THICKNESS 0.40)	JOINT DE CULASSE (EP. 0.40)	ZYLINDERKOPFDICHTUNG (STÄRKE 0.40)	JUNTA CULATA (SP. 0.40)	G03	9
8000A9371	GUARNIZIONE TESTA	HEAD GASKET	JOINT DE CULASSE	ZYLINDERKOPFDICHTUNG	JUNTA CULATA	G03	10
8000A9372	KIT MANTENIMENTO CARICA BATTERIA	BATTERY CHARGE MAINTENANCE KIT	KIT DE MAINTENANCE DE CHARGE DE BATTERIE	WARTUNGSBAUSATZ DER BATTERIELADUNG	KIT DE MANTENIMIENTO DE CARGA DE BATERÍA	H01	10

INDICE CODICI / DENOMINAZIONI

CODEX / DESIGNATION INDEX • INDEX CODES / DÉNOMINATIONS

INHALTSVERZEICHNIS CODE • ÍNDICE CÓDIGOS / DENOMINACIONES

Code	Denominazione	Description	Désignation	Bezeichnung	Descripción	Table	N°
8000A9639	PIASTRA DI BASE	BASE PLATE	PLAQUE DE BASE	TRAGPLATTE	PLACA DE BASE	J03	27
8000A9698	TARGHETTA DOCUM ENTAZIONE	DOCUMENTATION PLATE	PLAQUETTE DOCUMENTATION	UNTERLAGENSCHILD	ETIQUETA DOCUMENTACIÓN	E04	2
8000A9997	BUSSOLA	BUSH	BAGUE	HÜLSE	CASQUILLO	G16	15
8000A9998	BUSSOLA	BUSH	BAGUE	HÜLSE	CASQUILLO	G16	23
8000A9999	VITE SUPPORTO SCARICO	EXHAUST SYSTEM SUPPORT SCREW	VIS DE SUPPORT DU DISPOSITIF D'ÉCHAPPEMENT	ABGASANLAGE- HALTERUNGSSCHRAUBE	TORNILLO DE SOPORTE DEL DISPOSITIVO DE ESCAPE	G16	22
8000B0000	ROSETTA	WASHER	RONDELLE	UNTERLEGSCHIEBE	ARANDELA	G16	24
8000B0020	INGRANAGGIO 5°	5TH GEAR	PIGNON 5°	ZAHNRAD 5. GANG	ENGRANAJE 5°	G10	25
8000B0064	COLONNINA PER MOLLA	STUD BOLT FOR SPRING	GOUJON POUR RESSORT	FEDERSTIFT	PERNO PARA MUELLE	G17	28
8000B0066	CUSCINETTO	BEARING	ROULEMENT	LAGER	COJINETE	G17	25
8000B0067	PERNO	PIN	AXE	ZAPFEN	PERNO	G17	26
8000B0070	PIATTELLO INFERIORE MOLLA	SPRING LOWER CAP	COUPELLE INFERIEURE DU RESSORT	UNTERER FEDERTELLER	ASIENTO INFERIOR DEL MUELLE	G17	29
8000B0071	MOLLA	SPRING	RESSORT	FEDER	MUELLE	G17	31
8000B0072	SUPPORTO MOLLA	SPRING SUPPORT	SUPPORT DU RESSORT	FEDERHALTERUNG	SOPORTE MUELLE	G17	32
8000B0910	CRUSCOTTO COMPLETO	DASHBOARD ASSEMBLY	COMBINE DE BORD COMPLET	ARMATURENBRETT KOMPLETT	TABLERO COMPLETO	F01	1
8000B1014	FLANGIA	FLANGE	FLASQUE	FLANSCH	BRIDA	G17	2
8000B1015	MOZZO PORTADISCHI	DISK HUB	NOIX D'EMBRAYAGE	KUPPLUNGSSCHIEBENABE	CUBO PORTADISCOS	G17	1
8000B1019	PIATTO SPINGIDISCHI	DISK THRUST PLATE	PLATEAU DE PRESSION	DRUCKTELLER	PLATO DE PRESION	G17	8
8000B1198	INGRANAGGIO (ASPIRAZIONE)	GEAR (INTAKE)	PIGNON (ADMISSION)	ZAHNRAD (EINLASS)	ENGRANAJE (ADMISION)	G05	10
8000B1438	MAGLIA GIUNZIONE CATENA	CHAIN LINK	MAILLON DE JONCTION CHAINE	KETTENSCHLOSS	ESLABON UNION CADENA	C01	2
8000B1439	ATTREZZO TAGLIO CATENA	CHAIN CUTTING TOOL	OUTIL COUPE CHAINE	WERKZEUG FÜR SCHNITT DER KETTE	UTIL CORTE CADENA	J02	3
8000B1456	ATTREZZO CHIUSURA CATENA	CHAIN JOINING TOOL	OUTIL JOINDRE CHAINE	WERKZEUG FÜR VERLEIMEN DER KETTE	UTIL UNION CADENA	J02	4
8000B1457	ATTREZZO RIBADITURA CATENA	CHAIN RIVETING TOOL	OUTIL RIVETAGE CHAINE	WERKZEUG FÜR NIET DER KETTE	UTIL REMACHADO CADENA	J02	5
8000B1466	TUBO OLIO FRIZIONE	CLUTCH OIL PIPE	CANALISATION DE LIQUIDE EMBRAYAGE	LEITUNG KUPPLUNGSFLÜSSIGKEIT	TUBO ACEITE EMBRAGUE	D04	7
8000B1508	PROIETTORE ANTERIORE	HEADLIGHT	PROJECTEUR AVANT	SCHWEINWERFER	PROYECTOR DELANTERO	F02	1
8000B1539	ANTIVIBRANTE	VIBRATION-DAMPER	ANTI-VIBRATIONS	SCHWINGUNGSDÄMPFER	ANTIVIBRANTE	G08	8
8000B1542	PINZA FRENO ANTERIORE DX RH FRONT BRAKE CALIPER		ETRIER DE FREIN AVANT D.	VORDERER RECHTER BREMSSATTEL	PINZA FRENO DELANTERA DERECHA	C03	14
8000B1543	PINZA FRENO ANTERIORE SX LH FRONT BRAKE CALIPER		ETRIER DE FREIN AVANT G.	VORDERER LINKER BREMSSATTEL	PINZA FRENO DELANTERA IZQUIERDA	C03	9
8000B1544	PINZA FRENO ANTERIORE DX RH FRONT BRAKE CALIPER		ETRIER DE FREIN AVANT D.	VORDERER RECHTER BREMSSATTEL	PINZA FRENO DELANTERA DERECHA	C02	15
8000B1545	PINZA FRENO ANTERIORE SX LH FRONT BRAKE CALIPER		ETRIER DE FREIN AVANT G.	VORDERER LINKER BREMSSATTEL	PINZA FRENO DELANTERA IZQUIERDA	C02	9
8000B1593	COPPIA PASTIGLIE FRENO ANTERIORE	FRONT BRAKE PADS	PAIRE DE PLAQUETTES FREIN AVANT	BREMSBELAGPAAR VORDERRADBREMSE	PAR DE PASTILLAS FRENO DELANTERO	C02	10
8000B1601	COPPIA PASTIGLIE FRENO ANTERIORE	FRONT BRAKE PADS	PAIRE DE PLAQUETTES FREIN AVANT	BREMSBELAGPAAR VORDERRADBREMSE	PAR DE PASTILLAS FRENO DELANTERO	C03	10
8000B1602	MOLLA	SPRING	RESSORT	FEDER	MUELLE	C03	11
8000B1658	RETROVISORE DX	RH REARVIEW MIRROR	RETROVISEUR D.	RECHTER RÜCKSPIEGEL	RETROVISOR DERECHO	K01	18
8000B1659	RETROVISORE SX	LH REARVIEW MIRROR	RETROVISEUR G.	LINKER RÜCKSPIEGEL	RETROVISOR IZQUIERDO	K01	20
8000B1947	ASTA COMANDO FRIZIONE	CLUTCH CONTROL ROD	TIGE DE DEBRAYAGE	KUPPLUNGSSTANGE	VARILLA ACCIONAMIENTO EMBRAGUE	G17	13
8000B1948	SPURGO	DRAIN VALVE	VIS DE PURGE	ENTLÜFTUNGSSCHRAUBE	ESPURGO	C03	12
8000B1958	FLANGIA INFERIORE SERBATOIO	FUEL TANK LOWER FLANGE	PLATEAU INFERIEUR DU RESERVOIR	UNTERE TANKFLANSCH	SOPORTE INFERIOR DEPOSITO	G12	1
8000B1989	ALBERO ALTERNATORE	ALTERNATOR SHAFT	ARBRE ALTERNATEUR	LICHTMASCHINENWELLE	EJE ALTERNADOR	G14	1
8000B2031	INGRANAGGIO POMPA OLIO	OIL PUMP GEAR	PIGNON DE POMPE A HUILE	ÖLPUMPENZAHNRAD	ENGRANAJE BOMBA DE ACEITE	G06	19
8000B2036	CONTRALBERO	COUNTERSHAFT	CONTRE-ARBRE	VORGELEGEWELLE	CONTRAEJE	G02	10
8000B2037	DISTANZIALE	SPACER	ENTRETOISE	ABSTANDHALTER	DISTANCIADOR	G14	10
8000B2038	DISTANZIALE	SPACER	ENTRETOISE	ABSTANDHALTER	DISTANCIADOR	G14	8

INDICE CODICI / DENOMINAZIONI

 CODEX / DESIGNATION INDEX • INDEX CODES / DÉNOMINATIONS
 INHALTSVERZEICHNIS CODE • ÍNDICE CÓDIGOS / DENOMINACIONES

Code	Denominazione	Description	Désignation	Bezeichnung	Descripción	Table	N°
8000B2039	DISTANZIALE	SPACER	ENTRETOISE	ABSTANDHALTER	DISTANCIADOR	G14	14
8000B2046	ROSETTA	WASHER	RONDELLE	UNTERLEGSCHIBE	ARANDELA	G17	30
8000B2051	ATTREZZO FISSAGGIO VITE SUPPORTO SCARICO	EXHAUST SUPPORT SCREW FIXING TOOL	OUTIL DE FIXATION DE LA VIS D'ÉCHAPPEMENT	WERKZEUG FÜR ABGASKRÜMMER SCHRAUBEFESTLEGUNG	UTIL PARA LA FIJACIÓN DEL TORNILLO DEL ESCAPE	J04	9
8000B2055	ROSETTA	WASHER	RONDELLE	UNTERLEGSCHIBE	ARANDELA	G02	12
8000B2056	MOLLA A TAZZA	CUP SPRING	RESSORT À DIAPHRAGME	TASSENFEDER	MUELLE	G02	13
8000B2063	TUBO LUBRIFICAZIONE CAMBIO	CHANGE GEAR LUBRICATION PIPE	TUBE GRAISSAGE BOITE DE VITESSES	SCHMIERLEITUNG GETRIEBE	TUBO LUBRICACION CAMBIO	G01	21
8000B2065	SEMICUSCINETTO	BEARING, HALF	SEMI-ROULEMENT	LAGER	SEMICOJINETE	G01	29
8000B2066	GUARNIZIONE COPERCHIO	COVER GASKET	JOINT COUVERCLE	DICHTUNG DECKEL	JUNTA TAPA	G01	34
8000B2073	POMPA OLIO COMPLETA	OIL PUMP ASSEMBLY	POMPE A HUILE COMPLETE	ÖLPUMPE KOMPLETT	BOMBA DE ACEITE COMPLETA	G06	12
8000B2083	ALBERO SECONDARIO	TRANSMISSION SHAFT	ARBRE SECONDAIRE	VORGELEGEWELLE	ARBOL SECUNDARIO	G10	16
8000B2086	ALBERO COMANDO FORCELLE	FORK CONTROL SHAFT	BARILLET DE SELECTION	STEUERWELLE SCHALTGABELN	EJE ACCIONAMIENTO HORQUILLA	G11	10
8000B2114	SOFTWARE CENTRALINA INIEZIONE	POWER UNIT PROGRAMMING SOFTWARE	LOGICIEL BOITIER DE CONTROLE INJECTION	EINSPRITZ-STEUERUNG- SOFTWARE	SOFTWARE CENTRALITA INYECCION	J03	28
8000B2116	CHIAVE USB	USB KEY	CLÉ USB	USB SCHLÜSSEL	LLAVE USB	J03	29
8000B2117	CAVO SERIALE	SERIAL CABLE	CABLE SERIAL	SERIALKABEL	CABLE SERIAL	J03	30
8000B2118	CD-ROM SOFTWARE CENTRALINA INIEZIONE	POWER UNIT SOFTWARE CD-ROM	CD-ROM DU LOGICIEL BOITIER DE CONTROLE	CD-ROM EINSPRITZ- STEUERUNG-SOFTWARE	CD-ROM DEL SOFTWARE CENTRALITA INYECCION	J03	31
8000B2126	ATTUATORE VALVOLA DI SCARICO	EXHAUST VALVE ACTUATOR	ACTUATEUR SOUPAPE D'ÉCHAPP.	TRIEB AUSLASSVENTIL	ACCIONADOR VÁLVULA DE DESCARGA	G16	28
8000B2137	MOLLA	SPRING	RESSORT	FEDER	MUELLE	B04 B05 B06 B07	15 15 18 18
8000B2140	TUBO COMANDO GAS CON MANOPOLE	THROTTLE CONTROL PIPE WITH KNOBS	TUBE COMMANDE GAZ AVEC POIGNEES	ROHR GASGRIFF MIT HANDGRIFF	TUBO MANDO GAS CON PUÑO	D03	7
8000B2141	COMANDO GAS COMPLETO	THROTTLE CONTROL ASSEMBLY	COMMANDE GAZ COMPLETE	GASGRIFF KOMPLETT	MANDO GAS COMPLETO	D03	1
8000B2143	MOZZO ECCENTRICO	ECCENTRIC HUB	MOYEU DECENTRE	EXZENTERNABE	CUBO EXCENTRICO	C01	4
8000B2145	FLANGIA CORONA	GEAR FLANGE	FLASQUE	ZAHNKRANZFANSCH	BRIDA CORONA	C01	27
8000B2149	DISTANZIALE INTERNO	INNER SPACER	ENTRETOISE INTERNE	INNERES DISTANZSTÜCK	DISTANCIADOR INTERIOR	C01	6
8000B2150	BUSSOLA	BUSH	BAGUE	HÜLSE	CASQUILLO	C01	28
8000B2151	SILENT-BLOCK	SILENT BLOCK	SILENTBLOC	PUFFER	SILENT BLOCK	C01	30
8000B2164	DISTANZIALE E BOCCOLA	SPACER AND BUSH	ENTRETOISE ET BAGUE	ABSTANDHALTER UND HÜLSE	DISTANCIADOR Y CASQUILLO	B06 B07	17 17
8000B2512	ANELLO DI TENUTA	GROMMET	BAGUE D'ETANCHEITE	DICHTUNGSRING	RETEN	G06	17
8000B2518	DISTANZIALE E BOCCOLA	SPACER AND BUSH	ENTRETOISE ET BAGUE	ABSTANDHALTER UND HÜLSE	DISTANCIADOR Y CASQUILLO	B04 B05	14 14
8000B2532	FLANGIA CUSCINETTO	BEARING FLANGE	BRIDE DE PALIER	LAGERFLANSCH	BRIDA DE COJINETE	G01	19
8000B2548	ANELLO DI TENUTA	GROMMET	BAGUE D'ETANCHEITE	DICHTUNGSRING	RETEN	B04 B05	21 21
8000B2549	MOTORINO AVVIAMENTO	STARTER	DEMARREUR	ANLASSERMOTOR	MOTOR DE ARRANQUE	G15	10
8000B2556	ALBERO MOTORE COMPLETO	DRIVING SHAFT ASSEMBLY	VILEBREQUIN COMPLET	KURBELWELLE KOMPLETT	CIGÜEÑAL COMPLETO	G02	1
8000B2557	ALBERO MOTORE	DRIVING SHAFT	VILEBREQUIN	KURBELWELLE	CIGÜEÑAL	G02	2
8000B2560	PIASTRINA	PLATE	PLAQUETTE	BLECH	PLACA	G01	22
8000B2563	ROSETTA	WASHER	RONDELLE	UNTERLEGSCHIBE	ARANDELA	G02	16
8000B2574	ANELLO DI TENUTA	GROMMET	BAGUE D'ETANCHEITE	DICHTUNGSRING	RETEN	G07	2
8000B2607	SENSORE MARCE	GEAR SENSOR	CAPTEUR POSITION BOÎTE DE VIT.	SENSOR FÜR WECHSELGETREIBESTELLUNG	SENSOR POSICIÓN CAMBIO	G11	48
8000B2650	COLLETTORI DI SCARICO	EXHAUST MANIFOLDS	COLLECTEUR D'ÉCHAPPEMENT	ABGASKRÜMMER	COLACTORES DE ESCAPE	G16	21
8000B2673	VITE M4X8	M4X8 SCREW	VIS M4X8	SCHRAUBE M4X8	TORNILLO M4X8	A02	19
8000B2677	VITE M6X8	M6X8 SCREW	VIS M6X8	SCHRAUBE M6X8	TORNILLO M6X8	G16 G16	7 11
8000B2678	DADO M8	M8 SPRING	ECROU M8	MUTTER M8	TUERCA M8	K01	24



INDICE CODICI / DENOMINAZIONI
CODEX / DESIGNATION INDEX • INDEX CODES / DÉNOMINATIONS
INHALTSVERZEICHNIS CODE • ÍNDICE CÓDIGOS / DENOMINACIONES

Code	Denominazione	Description	Désignation	Bezeichnung	Descripción	Table	N°
8000B2681	VITE M8X8	M8X8 SCREW	VIS M8X8	SCHRAUBE M8X8	TORNILLO M8X8	F05	6
						F05	7
						F05	15
						G16	3
						G16	29
8000B2682	VITE M8X15	M8X15 SCREW	VIS M8X15	SCHRAUBE M8X15	TORNILLO M8X15	F03	2
8000B2687	VITE M5X8	M5X8 SCREW	VIS M5X8	SCHRAUBE M5X8	TORNILLO M5X8	E03	5
8000B2688	VITE M6X10	M6X10 SCREW	VIS M6X10	SCHRAUBE M6X10	TORNILLO M6X10	E03	10
						E05	27
8000B2689	VITE M7X25	M7X25 SCREW	VIS M7X25	SCHRAUBE M7X25	TORNILLO M7X25	B04	3
						B05	3
						B06	3
						B07	3
8000B2690	VITE M8X16	M8X16 SCREW	VIS M8X16	SCHRAUBE M8X16	TORNILLO M8X16	C02	6
8000B2706	DADO AUTOFRENANTE M4	M4 SELF LOCKING NUT	ECROU M4 DE SÉCURITÉ	MUTTER M4, SELBSTSICHERND	TUERCA M4 DE SEGURIDAD	A02	18
						A02	20
						K01	14
8000B2707	DADO M5	M5 SPRING	ECROU M5	MUTTER M5	TUERCA M5	E05	22
						F06	14
						G08	4
						G16	13
						K01	14
						K01	16
						K01	30
K02	10						
8000B2708	DADO M5	M5 SPRING	ECROU M5	MUTTER M5	TUERCA M5	F03	13
8000B2710	DADO AUTOFRENANTE M6	M6 SELF LOCKING NUT	ECROU M6 DE SÉCURITÉ	MUTTER M6, SELBSTSICHERND	TUERCA M6 DE SEGURIDAD	A02	16
8000B2711	DADO M6	M6 SPRING	ECROU M6	MUTTER M6	TUERCA M6	F03	21
8000B2712	DADO AUTOFRENANTE M8	M8 SELF LOCKING NUT	ECROU M8 DE SÉCURITÉ	MUTTER M8, SELBSTSICHERND	TUERCA M8 DE SEGURIDAD	A02	4
						B03	25
						C01	29
						G16	20
8000B2714	DADO M10	M10 SPRING	ECROU M10	MUTTER M10	TUERCA M10	B02	16
8000B2715	DADO M12	M12 SPRING	ECROU M12	MUTTER M12	TUERCA M12	A01	13
8000B2716	DADO M22	M22 SPRING	ECROU M22	MUTTER M22	TUERCA M22	G09	14
						G10	32
						G17	3
8000B2722	ROSETTA	WASHER	RONDELLE	UNTERLEGSCHIEBE	ARANDELA	E04	31
						F06	8
8000B2723	ROSETTA	WASHER	RONDELLE	UNTERLEGSCHIEBE	ARANDELA	D01	22
						D02	28
						D02	39
8000B2724	ROSETTA	WASHER	RONDELLE	UNTERLEGSCHIEBE	ARANDELA	F06	16
						K01	26
8000B2727	ROSETTA	WASHER	RONDELLE	UNTERLEGSCHIEBE	ARANDELA	K01	25
8000B2728	ROSETTA	WASHER	RONDELLE	UNTERLEGSCHIEBE	ARANDELA	B01	31
8000B2746	TAPPO	PLUG	BOUCHON	VERSCHLUSS	TAPON	G01	17
8000B2749	VITE PER ECCENTRICO	ECCENTRIC SCREW	VIS D'EXCENTRIQUE	SCHRAUBE FÜR EXZENTER	TORNILLO PARA EXCENTRICO	D01	6
						D02	6
8000B2750	VITE M12X30	M12X30 SCREW	VIS M12X30	SCHRAUBE M12X30	TORNILLO M12X30	A01	14
8000B2751	VITE M15X22	M15X22 SCREW	VIS M15X22	SCHRAUBE M15X22	TORNILLO M15X22	B01	32
8000B2752	VITE PER MOZZO RUOTA	WHEEL HUB SCREW	VIS DU MOYEU DU ROUE	SCHRAUBE FÜR RADNABE	TORNILLO PARA CUBO RUEDA	B01	29
8000B2755	VITE PER BILANCIERE	EQUALIZER SCREW	VIS DE BALANCIER	SCHRAUBE FÜR	TORNILLO PARA BALANCIN		
						HINTERRADSCHWINGE	B02

INDICE CODICI / DENOMINAZIONI

 CODEX / DESIGNATION INDEX • INDEX CODES / DÉNOMINATIONS
 INHALTSVERZEICHNIS CODE • ÍNDICE CÓDIGOS / DENOMINACIONES

Code	Denominazione	Description	Désignation	Bezeichnung	Descripción	Table	N°
8000B2756	VITE INF. FISSAGGIO MOTORE	ENGINE LOWER CLAMP SCREW	VIS INF. ANCRAGE MOTEUR	UNTERE MOTOR-BEFESTIGUNGSSCHRAUBE	TORNILLO INFERIOR FIJACION MOTOR	A01	12
8000B2757	VITE SUP. FISSAGGIO MOTORE	ENGINE UPPER CLAMP SCREW	VIS SUP. ANCRAGE MOTEUR	OBERE MOTOR-BEFESTIGUNGSSCHRAUBE	TORNILLO SUPERIOR FIJACION MOTOR	A01	11
8000B2759	VITE FISSAGGIO COPERCHIO	COVER CLAMP SCREW	VIS DE FIXATION COUVERCLE	BEFESTIGUNGSSCHRAUBE DECKEL	TORNILLO FIJACION TAPA	G04	27
8000B2762	SUPPORTO PINZA FRENO POSTERIORE	REAR BRAKE CALIPER SUPPORT	SUPPORT ETRIER DE FREIN ARRIERE	HALTERUNG BREMSSATTEL HINTERRADBREMSE	SOPORTE PINZA FRENO TRASERO	B01	9
8000B2763	VITE M10	M10 SCREW	VIS M10	SCHRAUBE M10	TORNILLO M10	B02	6
8000B2767	VITE M7	M7 SCREW	VIS M7	SCHRAUBE M7	TORNILLO M7	C01	12
8000B2768	PRIGIONIERO	STUD BOLT	GOUJON	STIFTSCHRAUBE	ESPARRAGO	G04	4
8000B2796	SILENZIATORE INFERIORE	LOWER SILENCER	SILENCIEUX INFERIEUR	UNTERER SCHALLDÄMPFER	SILENCIADOR INFERIOR	G16	9
8000B2797	SILENZIATORE SUPERIORE	UPPER SILENCER	SILENCIEUX SUPERIEUR	OBERER SCHALLDÄMPFER	SILENCIADOR SUPERIOR	G16	5
8000B2798	BUSSOLA	BUSH	BAGUE	HÜLSE	CASQUILLO	G13	15
8000B2799	DISTANZIALE	SPACER	ENTRETOISE	ABSTANDHALTER	DISTANCIADOR	F01	2
						F03	17
8000B2800	FORCELLINO	CLIP	RESSORT	FIXIERGABEL	HORQUILLA	D02	25
8000B2817	CONDOTTO MANDATA OLIO	OIL DELIVERY DUCT	CONDUIT REFOULEMENT HUILE	ÖL-ZULEITUNG	CONDUCTO ENVIO ACEITE	G06	22
8000B2841	COPERCHIO	COVER	COUVERCLE	DECKEL	TAPA	G11	1
8000B2844	VITE	SCREW	VIS	SCHRAUBE	TORNILLO	G11	20
8000B2847	PIASTRINA	PLATE	PLAQUETTE	BLECH	PLACA	G11	31
8000B2848	MOLLA RITEGNO	CHECK SPRING	PLAQUETTE D'APPUI	RÜCKHALTEFEDER	MUELLE RETENCION	G11	32
8000B2850	COPERCHIO	COVER	COUVERCLE	DECKEL	TAPA	G11	35
8000B2861	VITE	SCREW	VIS	SCHRAUBE	TORNILLO	F03	2
8000B2947	CODINO	TAIL	COQUE ARRIERE	HECKTEIL	COLA	E05	1
8000B2951	FIANCHETTO SX SERBATOIO	FUEL TANK LH SIDE	CACHE G. RESERVOIR	LINKE TANK-SEITENVERKLEIDUNG	LATERAL IZQUIERDO DEPOSITO	E04	5
8000B2952	FIANCHETTO DX SERBATOIO	FUEL TANK RH SIDE	CACHE D. RESERVOIR	RECHTE TANK-SEITENVERKLEIDUNG	LATERAL DERECHO DEPOSITO	E04	3
8000B2957	FIANCHETTO SX AIRBOX	AIRBOX LH SIDE	CACHE G. AIRBOX	LINKES AIRBOX-SEITENTEIL	LATERAL IZQUIERDO AIRBOX	E04	35
8000B2958	FIANCHETTO DX AIRBOX	AIRBOX RH SIDE	CACHE D. AIRBOX	RECHTES AIRBOX-SEITENTEIL	LATERAL DERECHO AIRBOX	E04	38
8000B2961	RETINA FIANCHETTO SX AIRBOX	AIRBOX LH SIDE NET	GRILLE CACHE G. AIRBOX	LINKES AIRBOX-SEITENTEIL GITTERNETZ	REDECILLA LATERAL IZQUIERDO AIRBOX	E04	36
8000B2962	RETINA FIANCHETTO DX AIRBOX	AIRBOX RH SIDE NET	GRILLE CACHE D. AIRBOX	RECHTES AIRBOX-SEITENTEIL GITTERNETZ	REDECILLA LATERAL DERECHO AIRBOX	E04	39
8000B2967	SENSORE VELOCITÀ	SPEED SENSOR	CAPTEUR DE VITESSE	GESCHWINDIGKEITSSENSOR	SENSOR VELOCIDAD	C01	38
8000B2968	SELLA PILOTA	DRIVER'S SADDLE	SELLE PILOTE	FAHRERSITZ	SILLIN PILOTO	E05	19
8000B2970	RITEGNO PER BATTERIA	BATTERY HOLDER	CALE POUR BATTERIE	BEFESTIGUNG FÜR BATTERIE	SUJETADOR PARA BATERIA	E05	18
8000B2971	SELLA PASSEGGERO	PILLION	SELLE PASSAGER	BEIFAHRSITZ	SILLIN PASAJERO	E05	24
8000B2978	MANUBRIO	HANDLEBAR	GUIDON	LENKER	MANILLAR	B03	16
8000B2979	STAFFA INTERRUPTORE ACCENSIONE	IGNITION LOCK SWITCH BRACKET	BRIDE CONTACTEUR D'ALLUMAGE	ZÜNDSCHLOSS-BEFESTIGUNG	BRIDA INTERRUPTOR DE ENCENDIDO	A01	22
8000B2982	GHIERA	RING NUT	ECROU	GEWINDERING	VIROLA	B03	10
8000B2984	COPRI INTERRUPTORE	IGNITION LOCK SWITCH	CACHE CONTACTEUR	ZÜNDSCHLOSS-	CUBRE INTERRUPTOR	A01	29
8000B2986	PORTA BATTERIA	BATTERY CARRIER	PORTE BATTERIE	BATTERIEHALTER	PUERTA BATERIA	A02	5
8000B2988	FANALE POSTERIORE	TAIL LAMP	FEU ARRIERE	RÜCKLICHT	PILOTO TRASERO	F06	1
8000B2990	CAVALLOTTO INFERIORE	LOWER U BOLT	ETRIER INFÉRIEURE	UNTERE BRÜCKE	BRIDA INFERIOR	B03	21
8000B2991	VITE BLOCCASTERZO	STEERING LOCK SCREW	VIS BUTÉE DE DIRECTION	SCHRAUBE LENKANGSCHLAG	TORNILLO SEGURO DE DIRECCION	A01	28
8000B2992	TAMPONE	PAD	TAMPON	PUFFER	TAPON	A01	26
8000B2994	PERNO ANCORAGGIO SELLA	SADDLE PIN	PIVOT D'ANCRAGE SELLE	BEFESTIGUNGSSCHRAUBE SITZBANK	PERNO ANCLAJE SILLIN	E05	7
8000B2996	PIASTRINA	PLATE	PLAQUETTE	BLECH	PLACA	F03	6
8000B2998	PIASTRINA	PLATE	PLAQUETTE	BLECH	PLACA	F05	14
8000B2999	TAMPONE	PAD	TAMPON	PUFFER	TAPON	F06	5
8000B3000	PERNO	PIN	AXE	ZAPFEN	PERNO	B03	19

INDICE CODICI / DENOMINAZIONI

CODEX / DESIGNATION INDEX • INDEX CODES / DÉNOMINATIONS

INHALTSVERZEICHNIS CODE • ÍNDICE CÓDIGOS / DENOMINACIONES

Code	Denominazione	Description	Désignation	Bezeichnung	Descripción	Table	N°
8000B3001	PIASTRINA	PLATE	PLAQUETTE	BLECH	PLACA	E05	11
8000B3003	TESTA DI STERZO	STEERING HEAD	TETE SUPERIEUR DIRECTION	LENKOPF CABEZA	TUBO DIRECCION	B03	11
8000B3004	VITE ANT. FISSAGGIO MOTORE	ENGINE FRONT CLAMP SCREW	VIS AV. ANCRAGE MOTEUR	VORDERE MOTOR-BEFESTIGUNGSSCHRAUBE	TORNILLO DELANTERO	A01	3
8000B3005	TUBO BENZINA	FUEL PIPE	CANALISATION ESSENCE	BENZINLEITUNG	TUBO GASOLINA	G13	20
8000B3006	TRASMISSIONE SERRATURA	LOCK TRANSMISSION	TRANSMISSION DE SERRURE	SELZUGSCHLIESSVORRICHTUNG	TRANSMISION CERRADURA	E05	12
8000B3007	STAFFA AGGANCIO SELLA	SEAT ATTACHMENT BRACKET	BRIDE ACCROCHAGE SELLE	EINHA KLÄTTCHEN SITZBANK	BRIDA ENGANCHE CILLÍN	E05	25
8000B3014	PIOLO	PIN	PIVOT	STIFT	ESPINA	G01	31
8000B3015	STAFFA SILENZIATORI	SILENCERS CLAMP	BRIDE SILENCIEUX	BEFESTIGUNG	BRIDA SILENCIADOR		
			D'ÉCHAPPEMENT	SCHÄLLDAMPFER	DE ESCAPE	G16	17
8000B3028	SUPPORTO	SUPPORT	SUPPORT	HALTERUNG	SOPORTE	F01	5
8000B3053	PROTEZIONE LATERALE SX RADIATORE	SIDE LH COOLER PROTECTION	PROTECTION LATERALE G. DE RADIATEUR	LINKER SEITEN-KÜHLERABDECKUNG	PROTECCION RADIADOR LATERAL IZQ.	E01	14
8000B3054	PROTEZIONE LATERALE DX RADIATORE	SIDE RH COOLER PROTECTION	PROTECTION LATERALE D. DE RADIATEUR	RECHTER SEITEN-KÜHLERABDECKUNG	PROTECCION RADIADOR LATERAL DER.	E02	12
8000B3085	STAFFA SERBATOIO	FUEL TANK BRACKET	BRIDE DE RESERVOIR	BEFESTIGUNG BENZINTANK	BRIDA DEPOSITO GASOLIN	A01	25
8000B3086	CAVALLOTTO SUPERIORE	UPPER U BOLT	ETRIER SUP.	OBERE BRÜCKE	BRIDA SUP.	B03	14
8000B3087	STAFFA	BRACKET	BRIDE	BEFESTIGUNG	BRIDA	G08	24
8000B3088	TUBO RADIATORE OLIO	OIL RADIATOR HOSE	TUYAU RADIATEUR HUILE	ÖLKÜHLERSCHLAUCH	TUBO RADIADOR ACEITE	G08	39
8000B3089	VITE FISSAGGIO PROIETTORE	HEADLIGHT CLAMP SCREW	VIS DE FIXATION	SCHWEINWERFER	TORNILLO FIJACION		
			PROJECTEUR	BEFESTIGUNGSSCHRAUBE	PROYECTOR	F02	7
8000B3090	LIMITATORE STERZATA	STEERING LIMITING DEVICE	LIMITEUR ANGLE DE BRAQUAGE	LENKBEGRENZER	LIMITADOR DE VIRAJE	B03	4
8000B3091	RADIATORE OLIO	OIL COOLER	RADIATEUR D'HUILE	ÖLKÜHLER	RADIADOR ACEITE	G08	33
8000B3093	PIASTRINA	PLATE	PLAQUETTE	BLECH	PLACA	G08	27
8000B3096	RADIATORE ACQUA	WATER COOLER	RADIATEUR D'EAU	KÜHLER	RADIADOR AGUA	G08	22
8000B3097	DISTANZIALE	SPACER	ENTRETOISE	ABSTANDHALTER	DISTANCIADOR	E01	18
						E02	17
8000B3101	PEDALE FRENO POSTERIORE	REAR BRAKE PEDAL	PEDALE FREIN ARRIERE	BREMSPEDAL	PEDAL FRENO TRASERO		
				HINTERRADBREMSE		D02	15
8000B3103	PEDALE CAMBIO	GEAR PEDAL	PEDALE DE SELECTION	SCHALTPEDAL	PEDAL CAMBIO	D01	15
8000B3108	CAVO TELERUTTORE/ BATTERIA	BATTERY/ELECTROMAGNETIC SWITCH CABLE	CABLE TELERUPTEUR/ BATTERIE	KABEL BATTERIE/ FERNRELAIS	CABLE TELERRUPTOR/ BATERIA	F05	10
8000B3109	CAVO TELERUTTORE/ MOTORINO AVVIAMENTO	BATTERY/STARTER CABLE	CABLE TELERUPTEUR/ DEMARREUR	KABEL BATTERIE/ ANLASSERMOTOR	CABLE TELERRUPTOR/ MOTOR DE ARRANQUE	F05	8
8000B3114	PERNO	PIN	AXE	ZAPFEN	PERNO	B03	20
8000B3117	INDICATORE DIREZIONE POST.	REAR TURN SIGNAL	INDICATEUR DIRECTION AR.	HINTERER BLINKER	INTERMITENTE TRASERO	F06	12
						F06	15
8000B3118	ANTIVIBRANTE	VIBRATION-DAMPER	ANTI-VIBRATIONS	SCHWINGUNGSDÄMPFER	ANTIVIBRANTE	F06	3
8000B3139	SERBATOIO BENZINA	FUEL TANK	RESERVOIR D'ESSENCE	BENZINTANK	DEPOSITO GASOLINA	E04	6
8000B3140	SERBATOIO BENZINA	FUEL TANK	RESERVOIR D'ESSENCE	BENZINTANK	DEPOSITO GASOLINA	E04	6
8000B3143	DADO PER SERRATURA	LOCK NUT	ECROU POUR SERRURE	MUTTER FÜR SCHLOSS	TUERCA PARA CERRADURA	E05	28
8000B3147	TELAJETTO POSTERIORE	REAR FRAME	CADRE ARRIERE	HINTERER KLEINER RAHMEN	CHASIS TRASERO	A02	1
8000B3149	SUPPORTO PEDANA ANTERIORE SX	LH FRONT FOOTBOARD SUPPORT	SUPPORT DE CALE-PIED AVANT GAUCHE	HALTERUNG VORDERE LINKE FUSSRASTE	SOPORTE ESTRIBO APOYAPIE DEL. IZQUIERDO	D01	1
8000B3154	DECAL	DECAL	ADHESIF	AUFKLEBER	CALCOMANIA	B03	13
8000B3155	COPERCHIO	COVER	COUVERCLE	DECKEL	TAPA	B03	27
8000B3157	REGISTRO	REGISTER	ECROU DE REGLAGE	EINSTELLVORRICHTUNG	REGULADOR	B02	3
8000B3158	SEMIBIELLA SUPERIORE	UPPER HALF SUPPORT	DEMI-BIELLE SUPERIEURE	OBERE SCHUBSTANGEN-HÄLFTE	SEMIBIELLA SUPERIOR	B02	1
8000B3159	DADO M12	M12 NUT	ECROU M12	MUTTER M12	TUERCA M12	B02	20
8000B3160	BUSSOLA	BUSH	BAGUE	HÜLSE	CASQUILLO	B02	5
8000B3163	CERCHIO RUOTA ANTERIORE	FRONT RIM	JANTE ROUE AVANT	VORDERRADFELGE	LLANTA RUEDA DELANTERA	C02	1
8000B3181	TARGHETTA "EMISSIONI"	"EMISSIONS" DATA PLATE	PLAQUETTE "EMISSIONS"	SCHILD "ABGASWERTE"	ETIQUETA "EMISIONES"	K01	6
8000B3182	TARGHETTA "RUMORE"	"NOISE" DATA PLATE	PLAQUETTE "BRUIT"	SCHILD "GERÄUSCHBELASTUNG"	ETIQUETA "RUIDOS"	K01	7
8000B3191	AMMORTIZZATORE DI STERZO	STEERING DAMPER	AMORTISSEUR DE DIRECTION	LENKUNGSDÄMPFER	AMORTIGUADOR DE DIRECCIÓN	B03	28

INDICE CODICI / DENOMINAZIONI

 CODEX / DESIGNATION INDEX • INDEX CODES / DÉNOMINATIONS
 INHALTSVERZEICHNIS CODE • ÍNDICE CÓDIGOS / DENOMINACIONES

Code	Denominazione	Description	Désignation	Bezeichnung	Descripción	Table	N°
8000B3195	VALVOLA	VALVE	VALVE	VENTIL	VALVULA	C01	3
						C02	4
						C03	4
8000B3198	PERNO RUOTA POSTERIORE	REAR WHEEL PIN	AXE ROUE ARRIERE	HINTERRADACHSE	PERNO RUEDA TRASERA	C01	7
8000B3200	DISTANZIALE	SPACER	ENTRETOISE	ABSTANDHALTER	DISTANCIADOR	C02	3
8000B3201	ANELLO DI TENUTA	GROMMET	BAGUE D'ETANCHEITE	DICHTUNGSRING	RETEN	G08	41
8000B3202	DECAL	DECAL	ADHESIF	AUFKLEBER	CALCOMANIA	E04	27
8000B3204	GRUPPO PRINCIPALE CAVI	MAIN CABLES SET	FAISCEAU PRINCIPAL	HAUPTKABELSTRANG	GRUPO CABLES PRINCIPALES	F01	14
8000B3205	BATTERIA	BATTERY	BATTERIE	BATTERIE	BATERIA	F05	9
8000B3206	REGOLATORE DI TENSIONE	VOLTAGE REGULATOR	REGULATEUR DE TENSION	SPANNUNGSREGLER	REGULADOR DE TENSION	F03	25
8000B3207	SENSORE TEMPERATURA ARIA	AIR TEMPERATURE SENSOR	CAPTEUR TEMPÉRATURE AIR	LUFTTEMPERATURSENSOR	SENSOR TEMPERATURA AIRE	F04	9
8000B3208	DECAL	DECAL	ADHESIF	AUFKLEBER	CALCOMANIA	E02	13
8000B3209	DECAL	DECAL	ADHESIF	AUFKLEBER	CALCOMANIA	E01	13
8000B3210	DECAL	DECAL	ADHESIF	AUFKLEBER	CALCOMANIA	F01	18
8000B3213	FIANCHETTO SX CODINO	TAIL LH SIDE FAIRING	CACHE G. COQUE ARRIERE	LINKE HECKTEIL-VERKLEIDUNG	LATERAL IZQUIERDO COLA	E05	5
8000B3214	FIANCHETTO DX CODINO	TAIL RH SIDE FAIRING	CACHE D. COQUE ARRIERE	RECHTE HECKTEIL-VERKLEIDUNG	LATERAL DERECHO COLA	E05	14
8000B3215	DECAL	DECAL	ADHESIF	AUFKLEBER	CALCOMANIA	E05	6
						E05	15
8000B3217	RELÉ INTERMITTENZA	INTERMITTENCE RELAY	RELAIS CLIGNOTANTS	BLINKRELAIS	RELÉ INTERMITENCIA	F01	24
8000B3218	CENTRALINA INIEZIONE	INJECTION POWER UNIT	BOITIER DE CONTR. INIECTION	EINSPRITZ-STEUERUNG	CENTRALITA INECCION	F03	19
8000B3219	GOMMINO	RUBBER COVER	CAOUTCHOUC	GUMMI	GOMA	F04	8
8000B3243	PROIETTORE ANTERIORE	HEADLIGHT	PROJECTEUR AVANT	SCHENWERFER	PROYECTOR DELANTERO	F02	1
8000B3244	PROIETTORE ANTERIORE	HEADLIGHT	PROJECTEUR AVANT	SCHENWERFER	PROYECTOR DELANTERO	F02	1
8000B3250	CHIAVE USB DOCUMENTAZ. DI PRODOTTO	PRODUCT DOCUMENTATION USB KEY	CLÉ USB DOCUMENTATION DE PRODUIT	USB SCHLÜSSEL - PRODUKT UNTERLAGEN	LLAVE USB DOCUMENTACIÓN DEL PRODUCTO	H01	6
						H01	1
8000B3254	CATALOGO RICAMBI	SPARE PARTS CATALOGUE	CATALOGUE PIECES DETACHEES	ERSATZTEILKATALOG	CATALOGO RECAMBIOS	H01	1
8000B3255	CD-ROM MANUALE OFFICINA MOTOTELAIO	CHASSIS OVERHAUL HANDBOOK CD-ROM	CD-ROM MANUEL MECANIQUE GENERALE	WERKSTATTHANDBUCH MOTORRADRAHMEN CD-ROM	CD-ROM MANUAL PARA TALLERES VEHICULO	H01	3
						H01	2
8000B3257	CD-ROM MANUALE OFFICINA MOTORE	ENGINE OVERHAUL HANDBOOK CD-ROM	CD-ROM MANUEL D'ATELIER MOTEUR	WERKSTATTHANDBUCH MOTOR CD-ROM	CD-ROM MANUAL PARA TALLERES MOTOR	H01	2
8000B3268	TESTA CILINDRI COMPLETA	CYLINDER HEAD ASSEMBLY	CULASSE COMPLETE	ZYLINDERKOPF KOMPLETT	CULATA COMPLETA	G04	1
8000B3272	COPERCHIO TESTA	HEAD COVER	COUVRE-CULASSE	ZYLINDERKOPFDECKEL	TAPA CULATA	G04	23
8000B3278	TRASMISSIONE PRIMARIA FRIZIONE	CLUTCH MAIN GEAR TRANSMISSION	TRANSMISSION PIGNON PRIMAIRE DEBRAYAGE	ÖFFNUNG KUPPLUNGS-ANTRIEBSWELLE	TRANSMISION PRIMARIA EMBRAGUE	G09	20
						G17	20
8000B3283	BASAMENTO COMPLETO	ENGINE BLOCK ASSEMBLY	CARTER MOTEUR COMPLET	KURBELGEHÄUSE KOMPLETT	BASE COMPLETA	G01	1
8000B3288	COPERCHIO	COVER	COUVERCLE	DECKEL	TAPA	G01	36
8000B3298	CORPO FARFALLATO	THROTTLE BODY	CORPS DE PAPILLON	DROSSELKÖRPER	CUERPO CON VALVULA DE MARIPOSA	G13	7
8000B3299	ALTERNATORE	ALTERNATOR	ALTERNATEUR	LICHTMASCHINE	ALTERNADOR	G15	8
8000B3301	INGRANAGGIO CONDOTTO	DRIVEN GEAR	ENGRENAGE ENTRAÎNÉ	ANGETRIEBENES ZAHNRAD	ENGRANAJE CONDUCIDO	G14	2
8000B3302	PARASTRAPPI ALTERNATORE	ALTERNATOR SPRING DRIVE	FLECTEUR ALTERNATEUR	REISSSCHUTZ LICHTMASCHINE	ACOPLAMIENTO FLEXIBLE ALTERNADOR	G14	3
						G14	4
8000B3303	ANELLO ESTERNO	OUTER PLATE	DISQUE EXTÉRIEUR	SCHEIBE, AUßEN	DISCO ESTERNO	G14	4
8000B3304	RUOTA LIBERA	FREEWHEEL	ROUE LIBRE	FREILAUF	RUEDA LIBRE	G14	5
8000B3305	FLANGIA RITEGNO RUOTA LIBERA	FREEWHEEL CHECK FLANGE	FLASQUE MANTIEN ROUE LIBRE	RÜCKHALTEFLANSCH FREILAUF	BRIDA RETENCION RUEDA LIBRE	G14	6
8000B3307	MOLLA A TAZZA	CUP SPRING	RESSORT À DIAPHRAGME	TASSENFEDER	MUELLE	G14	15
8000B3310	ALBERO SECONDARIO	TRANSMISSION SHAFT	ARBRE SECONDAIRE	VORGELEGEWELLE	ARBOL SECUNDARIO	G10	15
8000B3312	ROSETTA DI SICUREZZA	SAFETY WASHER	RONDELLE DE SURETE	SICHERUNGSSCHEIBE	ARANDELA DE SEGURIDAD	G09	13
						G10	34
8000B3313	ALBERO COMANDO FORCELLE	FORK CONTROL SHAFT	BARILLET DE SELECTION	STEUERWELLE SCHALTGABELN	EJE ACCIONAMIENTO HORQUILLA	G11	10
8000B3315	POMPA ACQUA COMPLETA	WATER PUMP ASSEMBLY	POMPE A EAU COMPLETE	WASSERPUMPE KOMPLETT	BOMBA AGUA COMPLETA	G07	1
8000B3332	TUBO POMPA/ PINZA FRENO	CALIPER PUMP PIPE	TUBE POMPE PINCES	BREMSPUMPENLEITUNG	TUBO BOMBA PINZAS	D02	34
8000B3340	BASE DI STERZO CON PERNO	STEERING BASE WITH PIN	TETE INFERIEUR AVEC AXE	LENKAUFLAGE MIT ZAPFEN	BASE DE LA DIRECCION CON PERNO	B03	3
						B03	3



INDICE CODICI / DENOMINAZIONI
CODEX / DESIGNATION INDEX • INDEX CODES / DÉNOMINATIONS
INHALTSVERZEICHNIS CODE • ÍNDICE CÓDIGOS / DENOMINACIONES

Code	Denominazione	Description	Désignation	Bezeichnung	Descripción	Table	N°
8000B3344	CENTRALINA INIEZIONE	INJECTION POWER UNIT	BOITIER DE CONTR. INIECTION	EINSPRITZ-STEUERUNG	CENTRALITA INYECCION	F03	19
8000B3345	PROTEZIONE SERBATOIO	FUEL TANK PROTECTION	PROTECTION DERESERVOIR	BENZINTANK ABDECKUNG	PROTECCION PARA DEPOSITO	E04	14
8000B3352	CERCHIO RUOTA ANTERIORE	FRONT RIM	JANTE ROUE AVANT	VORDERRADFELGE	LLANTA RUEDA DELANTERA	C03	1
8000B3353	DISCO FRENO ANTERIORE	FRONT BRAKE DISK	DISQUE FREIN AV.	BREMSSSCHEIBE	DISCO FRENO DELANTERO		
				VORDERRADBREMSE		C03	5
8000B3368	TARGHETTA "EMISSIONI"	"EMISSIONS" DATA PLATE	PLAQUETTE "EMISSIONS"	SCHILD "ABGASWERTE"	ETIQUETA "EMISIONES"	K01	6
8000B3381	SUPPORTO PROIETTORE	HEADLIGHT SUPPORT	SUPPORT DE PROJECTEUR	SCHLEINWERFER HALTERUNG	SOPORTE PROYECTOR	F01	22
8000B3382	MOTORE COMPLETO	ENGINE ASSEMBLY	MOTEUR COMPLET	MOTOR KOMPLETT	MOTOR COMPLETO	G01	55
8000B3383	SERBATOIO BENZINA	FUEL TANK	RESERVOIR D'ESSENCE	BENZINTANK	DEPOSITO GASOLINA	E04	6
8000B3384	SERBATOIO BENZINA	FUEL TANK	RESERVOIR D'ESSENCE	BENZINTANK	DEPOSITO GASOLINA	E04	6
8000B3386	FIANCHETTO DX CODINO	TAIL RH SIDE FAIRING	CACHE D. COQUE ARRIERE	RECHTE HECKTEIL- VERKLEIDUNG	LATERAL DERECHO COLA		
						E05	14
8000B3387	FIANCHETTO SX CODINO	TAIL LH SIDE FAIRING	CACHE G. COQUE ARRIERE	LINKE HECKTEIL-VERKLEIDUNG	LATERAL IZQUIERDO COLA	E05	5
8000B3390	FLANGIA CORONA	GEAR FLANGE	FLASQUE	ZAHNKRANZFLANSCH	BRIDA CORONA	C01	37
8000B3398	GOMMA PARASTRAPPI	FLEXIBLE COUPLING RUBBER	CAOUTCHOUC AMORT. DE TRANSM.	ELASTISCHE KUPPLUNG GUMMI	GOMA JUNTA AMORTIGUADORA		
						G02	11
8000B3415	TESTA CILINDRI COMPLETA	CYLINDER HEAD ASSEMBLY	CULASSE COMPLETE	ZYLINDERKOPF KOMPLETT	CULATA COMPLETA	G04	1
8000B3432	SENSORE PRESSIONE	PRESSURE SENSOR	CAPTEUR DE PRESSION	DRUCKSENSOR	SENSOR DE PRESION	G13	34
8000B3433	SUPPORTO FILTRO OLIO	OIL FILTER SUPPORT	SUPPORT FILTRE A HUILE	ÖLFILTERHALTERUNG	SOPORTE FILTRO ACEITE	G06	1
8000B3434	MOTORE COMPLETO	ENGINE ASSEMBLY	MOTEUR COMPLET	MOTOR KOMPLETT	MOTOR COMPLETO	G01	55
8000B3440	ANTIVIBRANTE	VIBRATION-DAMPER	ANTI-VIBRATIONS	SCHWINGUNGSDÄMPFER	ANTIVIBRANTE	B03	22
8000B3441	ANTIVIBRANTE	VIBRATION-DAMPER	ANTI-VIBRATIONS	SCHWINGUNGSDÄMPFER	ANTIVIBRANTE	B03	23
8000B3443	TUBO IN GOMMA	HOSE	DURIT	GUMMISCHLAUCH	TUBO DE GOMA	K02	7
8000B3444	ASSIEME REGOLAZIONE	ADJUSTMENT ASSEMBLY	GROUPE DE REGLAGE	EINSTELLUNG EINHEIT	GRUPO DE REGULACION	F02	6
8000B3445	TUBO VALVOLA ARIA SECONDARIA	SECONDARY AIR VALVE PIPE	TUYAU DU SOUPEPE DE L'AIR SECONDAIRE	SEKUNDÄRLUFTVENTIL- LEITUNG	TUBO VALVULA DEL AIRE SECUNDARIO	G13	25
8000B3448	TUBO OLIO	OIL TUBE	TUYAU HUILE	ÖLSCHLAUCH	TUBO ACEITE	G06	4
8000B3449	ANELLO DI TENUTA	GROMMET	BAGUE D'ETANCHEITE	DICHTUNGSRING	RETEN	G06	8
8000B3450	FILTRO OLIO (ASPIRAZIONE)	OIL FILTER (INTAKE)	FILTRE A HUILE (ADMISSION)	ÖLFILTER (ANSAUGFILTER)	FILTRO ACEITE (ASPIRACION)	G06	9
8000B3451	MOLLETTA	SPRING	RESSORT	FEDERKLAMMER	MUELLE	G06	10
8000B3452	POMPA FRENO ANTERIORE	FRONT BRAKE PUMP	MAITRE-CYLINDRE FREIN AVANT	BREMSPUMPE VORDERRADBREMSE	BOMBA FRENO DELANTERO	D03	14
8000B3453	POMPA FRIZIONE	CLUTCH PUMP	MAITRE-CYLINDRE D'EMBAYAGE	KUPPLUNGSPUMPE	BOMBA EMBRAGUE	D04	4
8000B3455	GUARNIZIONE	GASKET	JOINT	DICHTUNG	EMPAQUE	G01	44
8000B3457	ANELLO DI TENUTA	GROMMET	BAGUE D'ETANCHEITE	DICHTUNGSRING	RETEN	G01	48
8000B3458	PIASTRINA	PLATE	PLAQUETTE	BLECH	PLACA	G04	30
8000B3461	DECAL	DECAL	ADHESIF	AUFKLEBER	CALCOMANIA	B03	13
8000B3470	ALBERO COMANDO SELETTORE	SELECTOR CONTROL SHAFT	ARBRE COMMANDE SELECTEUR	STEUERWELLE GANGWAHL	EJE MANDO SELECTOR	G11	30
8000B3474	ROSETTA	WASHER	RONDELLE	UNTERLEGSCHEIBE	ARANDELA	B03	24
8000B3491	ANELLO	RING	CIRCLIPS	RING	ANILLO	B02	10
8000B3493	FANALE TARGA	NUMBER PLATE LIGHT	ECLAIREUR	NUMMERN-SCHILD-BELEUCHTUNG	LUZ PLACA	F06	2
8000B3497	SENSORE TEMPERATURA ACQUA	WATER TEMPERATURE SENSOR	CAPTEUR TEMPÉRATURE EAU	WASSTERTEMPÉRATURFÜHLER	SENSOR TEMPERATURA DE AGUA	G15	6
8000B3500	SUPPORTO PEDANA ANTERIORE DX	RH FRONT FOOTBOARD SUPPORT	SUPPORT DE CALE-PIED AVANT DROITE	HALTERUNG VORDERE RECHTE FUSSRASTE	SOPORTE ESTRIBO APOYAPIE DEL. DERECHO		
						D02	1
8000B3518	DECAL	DECAL	ADHESIF	AUFKLEBER	CALCOMANIA	E04	27
8000B3520	PARAFANGO ANTERIORE	FRONT MUDGUARD	GARDE-BOUE AVANT	VORDERER KOTFLÜGEL	GUARDABARRO DELANTERO	E01	1
8000B3522	PROTEZIONE	PROTECTION	PROTECTION	ABDECKUNG	PROTECCION	G11	43
8000B3525	RACCORDO FILETTATO	THREAD CONNECTION	ORIFICE	GEWINDEANSCHLUSS	CONEXIÓN ENROSCADA	G13	2
8000B3583	CAVALLETTO LATERALE	SIDE STAND	BEQUILLE LATERALE	SEITENSTÄNDER	CABALLETE LATERAL	A01	16
8000B3584	PIASTRINA AGGANCIAMENTO MOLLA	BRACKET SPRING	PLAQUETTE ACCROCH.RESSORT	PLÄTTCHEN FEDERANLENKUNG	PLACA ENG. MUELLE	A01	19
8000B3622	PATTINO SUPERIORE CATENA	CHAIN UPPER PAD	PATIN SUPERIEUR CHAINE	OBERE KETTENFÜHRUNG	PATIN SUPERIOR CADENA	B01	11
8000B3623	PATTINO INFERIORE CATENA	CHAIN LOWER PAD	PATIN INFERIEUR CHAINE	UNTERE KETTENFÜHRUNG	PATIN INFERIOR CADENA	B01	15
8000B3629	PROTEZIONE	PROTECTION	PROTECTION	ABDECKUNG	PROTECCION	B01	17
8000B3638	TAPPO RADIATORE	RADIATOR PLUG	BOUCHON RADIATEUR	KÜHLERDECKEL	TAPA DE RADIADOR	G08	76

INDICE CODICI / DENOMINAZIONI

 CODEX / DESIGNATION INDEX • INDEX CODES / DÉNOMINATIONS
 INHALTSVERZEICHNIS CODE • ÍNDICE CÓDIGOS / DENOMINACIONES

Code	Denominazione	Description	Désignation	Bezeichnung	Descripción	Table	N°
8000B3667	SUPPORTO PEDANA ANTERIORE SX	LH FRONT FOOTBOARD SUPPORT	SUPPORT DE CALE-PIED AVANT GAUCHE	HALTERUNG VORDERE LINKE FUSSRASTE	SOPORTE ESTRIBO APOYAPIE DEL. IZQUIERDO	D01	1
8000B3668	SUPPORTO PEDANA ANTERIORE DX	RH FRONT FOOTBOARD SUPPORT	SUPPORT DE CALE-PIED AVANT DROITE	HALTERUNG VORDERE RECHTE FUSSRASTE	SOPORTE ESTRIBO APOYAPIE DEL. DERECHO	D02	1
8000B3669	BIELLA PER PEDANA	FOOTBOARD SUPPORT	BIELLETTE DE CALE-PIED	STANGE FUSSRASTE	BIELA PARA APOYAPIE	D01 D02	2 2
8000B3672	DISTANZIALE	SPACER	ENTRETOISE	ABSTANDHALTER	DISTANCIADOR	C03	3
8000B3673	GOMMINO	RUBBER COVER	CAOUTCHOUC	GUMMI	GOMA	G16	30
8000B3674	BUSSOLA	BUSH	BAGUE	HÜLSE	CASQUILLO	G16	31
8000B3747	FLANGIA PORTATARGA/ CATADIOTTRI	NUMBER PLATE HOLDER/ RETROREFLECTORS FLANGE	FLASQUE SUPPORT DE PLAQUE/REFLECTEURS	BEFESTIGUNGSFLANSCH - NUMMERN SCHILD	BRIDA PORTAPLACA/ CATAFARROS	K01	10
8000B3849	TUBO OLIO FRENO ANTERIORE	FRONT BRAKE OIL PIPE	CANALISATION DE LIQUIDE FREIN AVANT	BREMSLEITUNG VORDERRADBREMSE	TUBO ACEITE FRENO DELANTERO	D03	17
8000B3850	TUBO OLIO FRENO ANTERIORE	FRONT BRAKE OIL PIPE	CANALISATION DE LIQUIDE FREIN AVANT	BREMSLEITUNG VORDERRADBREMSE	TUBO ACEITE FRENO DELANTERO	D03	17
8000B3870	PROFILO DX	R. H. PROFILE	PROFIL DROIT	RECHTE PROFIL	TIRA DER.	E05	29
8000B3871	PROFILO SX	L. H. PROFILE	PROFIL GAUCHE	LINKE PROFIL	TIRA IZQ.	E05	30
8000B3872	DECAL	DECAL	ADHESIF	AUFKLEBER	CALCOMANIA	D02	40
8000B3970	PIASTRINA	PLATE	PLAQUETTE	BLECH	PLACA	G14	17
8000B3972	PARAFANGO ANTERIORE	FRONT MUDGUARD	GARDE-BOUE AVANT	VORDERER KOTFLÜGEL	GUARDABARRO DELANTERO	E01	1
8000B3974	PIASTRA	PLATE	PLAQUE	PLATTE	PLACA	A01	15
8000B3978	PATTINO CATENA	CHAIN PAD	PATIN CHAINE	KETTEN-FÜHRUNGSSCHUH	PATIN CADENA	A01	7
8000B3980	BILANCIERE	LEVER	BALANCIER	KIPPEBEL	BALANCIN	B02	9
8000B3982	FLANGIA PORTATARGA/ CATADIOTTRO	NUMBER PLATE HOLDER/ RETROREFLECTOR	FLASQUE SUPPORT DE PLAQUE/FLANGE	BEFESTIGUNGSFLANSCH - NUMMERN SCHILDBEFESTI-	BRIDA PORTAPLACA/ CATAFARROS	A02	14
8000B3984	AMMORTIZZATORE POST.	REAR SHOCK ABSORBER	AMORTISSEUR ARRIERE	HINTERER STOSSDÄMPFER	AMORTIGUADOR TRASERO	B02	17
8000B3985	AMMORTIZZATORE POST.	REAR SHOCK ABSORBER	AMORTISSEUR ARRIERE	HINTERER STOSSDÄMPFER	AMORTIGUADOR TRASERO	B02	17
8000B3986	MOLLA INTERNA	INNER SPRING	RESSORT INT.	INNENFEDER	MUELLE INT.	A01	30
8000B3987	MOLLA ESTERNA	OUTER SPRING	RESSORT EXT.	AUSSENFEDER	MUELLE EXT.	A01	27
8000B4001	TAPPO SX	LH PLUG	BOUCHON G.	LINKER VERSCHLUSS	TAPON IZQUIERDO	K01	21
8000B4002	TAPPO DX	RH PLUG	BOUCHON D.	RECHTER VERSCHLUSS	TAPON DERECHO	K01	19
8000B4014	TAPPO DI CHIUSURA	PLUG	BOUCHON	VERSCHLUSS	TAPON	A01	36
8000B4015	TARGHETTA REGOLAZIONE CATENA	CHAIN ADJUSTMENT PLATE	PLAQUETTE REGLAGE CHAINE	SCHILD KETTENEINSTELLUNG	ETIQUETA REGULACION CADENA	B01	26
8000B4016	COPRICATENA INFERIORE	LOWER CHAIN COVER	CARTER DE CHAINE INFERIEUR	UNTERER KETTENSCHUTZ	CUBRECADENA INFERIOR	B01	25
8000B4018	PROTEZIONE	PROTECTION	PROTECTION	ABDECKUNG	PROTECCION	D02	11
8000B4019	GUARNIZIONE	GASKET	JOINT	DICHTUNG	EMPAQUE	G01	4
8000B4023	WELCOME KIT	WELCOME KIT	WELCOME KIT	WELCOME KIT	WELCOME KIT	H01	4
8000B4024	WELCOME KIT	WELCOME KIT	WELCOME KIT	WELCOME KIT	WELCOME KIT	H01	4
8000B4025	WELCOME KIT	WELCOME KIT	WELCOME KIT	WELCOME KIT	WELCOME KIT	H01	4
8000B4026	WELCOME KIT	WELCOME KIT	WELCOME KIT	WELCOME KIT	WELCOME KIT	H01	4
8000B4029	DECAL	DECAL	ADHESIF	AUFKLEBER	CALCOMANIA	E04	40
8000B4030	DECAL	DECAL	ADHESIF	AUFKLEBER	CALCOMANIA	E05	31
8000B4031	DECAL	DECAL	ADHESIF	AUFKLEBER	CALCOMANIA	E01	20
8000B4032	DECAL	DECAL	ADHESIF	AUFKLEBER	CALCOMANIA	E04	34
8000B4033	KIT CATENA-CORONA-PIGNONE	CHAIN-RING GEAR-SPROCKET KIT	KIT CHÂNE-COURONNE-PIGNON	KETTEN-KRANZ-RITZEL BAUSATZ	KIT CATENA-CORONA-PIÑON	C01	35
8000B4056	GUARNIZIONE	GASKET	JOINT	DICHTUNG	EMPAQUE	G04	24
8000B4065	TAMBURO SELETTOR MARCE	GEARS SELECTING DRUM	TAMBOUR DE SELECTION	GANGWAHLTROMMEL	TAMBOR SELECTOR MARCHA	G11	18
8000B4079	RETROVISORE SX	LH REARVIEW MIRROR	RETROVISEUR G.	LINKER RÜCKSPIEGEL	RETROVISOR IZQUIERDO	E02	2
8000B4080	RETROVISORE DX	RH REARVIEW MIRROR	RETROVISEUR D.	RECHTER RÜCKSPIEGEL	RETROVISOR DERECHO	E02	1
8000B4083	TAPPO	PLUG	BOUCHON	VERSCHLUSS	TAPON	E02 E02	7 11
8000B4084	MOLLA	SPRING	RESSORT	FEDER	MUELLE	E02 E02	5 9



INDICE CODICI / DENOMINAZIONI
CODEX / DESIGNATION INDEX • INDEX CODES / DÉNOMINATIONS
INHALTSVERZEICHNIS CODE • ÍNDICE CÓDIGOS / DENOMINACIONES

Code	Denominazione	Description	Désignation	Bezeichnung	Descripción	Table	N°
8000B4085	SCODELLINO	STOP WASHER	RONDELLE D'AR	FEDERAUFNAHME	PLATILLO	E02	4
8000B4086	PERNO	PIN	AXE	ZAPFEN	PERNO	E02 E02	3 8
8000B4108	SUPPORTO ATTUATORE	ACTUATOR HOLDER	SUPPORT ACTUATEUR	LAGER FÜR TRIEB	SOPORTE ACCIONADOR	G16	27
8000B4109	TRASMISSIONE APERTURA	OPENING TRANSMISSION	TRANSMISSION OUVERTURE	BOWDENZÜG ÖFFNUNG	TRANSMISION ABERTURA	G16	34
8000B4110	PIASTRINA	PLATE	PLAQUETTE	BLECH	PLACA	G16	35
8000B4111	PROTEZIONE	PROTECTION	PROTECTION	ABDECKUNG	PROTECCION	D01	11
8000B4112	PROTEZIONE	PROTECTION	PROTECTION	ABDECKUNG	PROTECCION	G16	2
8000B4114	TRASMISSIONE CHIUSURA	CLOSING TRANSMISSION	TRANSMISSION FERMETURE	BOWDENZÜG SCHLIESSEN	TRANSMISION CIERRE	G16	33
8000B4115	VITE M4X12	M4X12 SCREW	VIS M4X12	SCHRAUBE M4X12	TORNILLO M4X12	E05	32
8000B4116	SUPPORTO	SUPPORT	SUPPORT	HALTERUNG	SOPORTE	G11	21
8000B4120	FORM ATTIVAZIONE GARANZIA	WARRANTY ACTIVATION FORM	MODULE D'ACTIVATION DE GARANTIE	GARANTIEAKTIVIERUNG	MÓDULO DE ACTIVACIÓN DE LA GARANTIA	H01	5
8000B4129	MATERIALE FONOASSORBENTE	SOUND-ABSORBING MATERIAL	MATÉRIAU INSONORE	SCHALLDÄMPFENDEM	MATERIAL FONOAASSORBENTE	E04	15
8000B4140	PISTONE COMPLETO	PISTON ASSEMBLY	PISTON COMPLET	KOLBEN KOMPLETT	PISTON COMPLETO	G03	2
8000B4141	GRUPPO SEGMENTI PISTONE	PISTON RING ASSEMBLY	GROUPE SEGMENTS PISTON	BAUGRUPPE KOLBENRINGE	CONJUNTO AROS DEL PISTON	G03	3
8000B4190	GUSCIO SUPERIORE AIRBOX	AIRBOX UPPER BEARING	COQUE SUPERIEURE AIRBOX	OBERE AIRBOXSCHALEN	CASCO SUPERIOR AIRBOX	E03	2
8000B4191	AIRBOX COMPLETO	AIRBOX ASSEMBLY	AIRBOX COMPLET	AIRBOX KOMPLETT	AIRBOX COMPLETO	E03	1
8000B4192	CONDOTTO ARIA DX	RH AIR DUCT	CONDUIT AIRE D.	RECHTER LUFTSTUTZEN	CONDUCTO AIRE DERECHO	E03	15
8000B4193	CONDOTTO ARIA SX	LH AIR DUCT	CONDUIT AIRE G.	LINKER LUFTSTUTZEN	CONDUCTO AIRE IZQUIERDO	E03	3
8000B4203	DECAL	DECAL	ADHESIF	AUFKLEBER	CALCOMANIA	A01	31
8000B4218	PIASTRINA	PLATE	PLAQUETTE	BLECH	PLACA	F01	16
8000B4220	MOLLA	SPRING	RESSORT	FEDER	MUELLE	G11	23
8000B4230	PROTEZIONE FASCETTA	CLAMP PROTECTION	PROTECTION COLLIER	SHELLESCHUTZ	PROTECCIÓN ABRAZADERA	G13	33
8000B4231	DISTANZIALE	SPACER	ENTRETOISE	ABSTANDHALTER	DISTANCIADOR	K01	13
8000B4248	PROTEZIONE	PROTECTION	PROTECTION	ABDECKUNG	PROTECCION	F01	23
8000B4258	CARTUCCIA REGOLAZIONE ESTENSIONE	REBOUND DAMPING ADJUSTMENT CARTRIDGE	CARTOUCHE DE REGLAGE DU FREINAGE EN DETENTE	PATRONE FÜR AUSDEHNUNGSEINSTELLUNG	CARTUCHO DE REGULACION FRENADO EN EXTENSION	B04	12
8000B4259	CARTUCCIA REGOLAZIONE ESTENSIONE	REBOUND DAMPING ADJUSTMENT CARTRIDGE	CARTOUCHE DE REGLAGE DU FREINAGE EN DETENTE	PATRONE FÜR AUSDEHNUNGSEINSTELLUNG	CARTUCHO DE REGULACION FRENADO EN EXTENSION	B05	12
8000B4260	GRUPPO ASTA	ROD ASSY	GROUPE TIGE	STANGEGRUPPE	VARILLA	B04 B05	23 23
8000B4261	MOLLA	SPRING	RESSORT	FEDER	MUELLE	B04 B05 B06 B07	18 18 21 21
8000B4262	TAPPO COMPLETO	PLUG ASSEMBLY	BOUCHON COMPLET	VERSCHLUSS KOMPLETT	TAPON COMPLETO	B04	22
8000B4263	CARTUCCIA REGOLAZIONE ESTENSIONE	REBOUND DAMPING ADJUSTMENT CARTRIDGE	CARTOUCHE DE REGLAGE DU FREINAGE EN DETENTE	PATRONE FÜR AUSDEHNUNGSEINSTELLUNG	CARTUCHO DE REGULACION FRENADO EN EXTENSION	B06	12
8000B4264	CARTUCCIA REGOLAZIONE ESTENSIONE	REBOUND DAMPING ADJUSTMENT CARTRIDGE	CARTOUCHE DE REGLAGE DU FREINAGE EN DETENTE	PATRONE FÜR AUSDEHNUNGSEINSTELLUNG	CARTUCHO DE REGULACION FRENADO EN EXTENSION	B07	12
8000B4265	TAPPO COMPLETO	PLUG ASSEMBLY	BOUCHON COMPLET	VERSCHLUSS KOMPLETT	TAPON COMPLETO	B06	24
8000B4275	VALVOLA	VALVE	VALVE	VENTIL	VALVULA	B06 B07	15 15
8000B4276	ANELLO DI TENUTA	GROMMET	BAGUE D'ETANCHEITE	DICHTUNGSRING	RETEN	G12	2
8000B4277	TERMISTORE	THERMISTOR	THERMISTOR	THERMISTOR	TERMISTOR	G12	3
8000B4278	FILTRO BENZINA	FUEL FILTER	FILTRE A ESSENCE	BENZINFILTER	FILTRO GASOLINA	G12	4
8000B4291	LAMPADA H7 12V 55W	H7 12V 55W BULB	AMPOULE H7 12V 55W	LAMPE H7 12V 55W	LAMPARA H7 12V 55W	F02 F02	2 3
8000B4292	TAPPO	PLUG	BOUCHON	VERSCHLUSS	TAPON	F02	4
8000B4293	CUFFIA FANALE	HEADLIGHT COVER	COIFFE POUR PHARE	SCHWEINWERFERHAUBE	PROTECCIÓN FARO	F02	5
8000B4308	VITE	SCREW	VIS	SCHRAUBE	TORNILLO	G07	3
8000B4309	KIT GUARNIZIONI TESTA	HEAD GASKET KIT	KIT DES JOINTS DE CULASSE	ZYLINDERKOPFDICHTUNG- BAUSATZ	KIT DE JUNTAS CULATA	J04	7
8000B4310	KIT GUARNIZIONI BASAMENTO	CYLINDER BASE GASKET KIT	KIT DES JOINTS D'EMBASE	MOTORBLOCKDICHTUNG- BAUSATZ	KIT DE JUNTAS BASE	J04	8

INDICE CODICI / DENOMINAZIONI

 CODEX / DESIGNATION INDEX • INDEX CODES / DÉNOMINATIONS
 INHALTSVERZEICHNIS CODE • ÍNDICE CÓDIGOS / DENOMINACIONES

Code	Denominazione	Description	Désignation	Bezeichnung	Descripción	Table	N°
8000B4312	INIETTORE	INJECTOR	INJECTEUR	EINSPRITZDÜSE	INYECTOR	G13	36
8000B4313	MOLLETTA	SPRING	RESSORT	FEDERKLAMMER	MUELLE	G13	37
8000B4314	KIT VITE-ROSETTA	SCREW-WASHER KIT	KIT VIS-RONDELLE	SCHRAUBEN-U.SCHIEBE KIT	KIT TORNILLO-ARANDELA	G13	38
8000B4316	ANELLO DI TENUTA	GROMMET	BAGUE D'ETANCHEITE	DICHTUNGSRING	RETEN	G13	40
8000B4317	KIT VITI REGOLAZIONE BY-PASS	BY-PASS ADJUSTMENT SCREWS KIT	KIT VIS DE REGLAGE	UMBAUSATZ EINSTELLUNGSSCHRAUBEN	KIT TORNILLOS DE REGULACION	G13	41
8000B4318	KIT CAPPUCCIO-MOLLETTA	CAP-SPRING KIT	KIT CAPUCHON-RESSORT	KAPPE-FEDERKLAMMER KIT	KIT CAPUCHON-MUELLE	G13	42
8000B4319	KIT BRACCETTO-VITI	BRACKET-SCREWS KIT	KIT BRIDE-VIS	BEFESTIGUNG-SCHRAUBEN	KIT BRIDA-TORNILLOS	G13	43
8000B4320	KIT FLAUTO BENZINA	FEED MANIFOLD KIT	KIT COLLECTEUR D'ESSENCE	VERSORGUNGSSTUTZEN KIT	KIT COLECTOR DE GASOLINA	G13	39
8000B4326	LEVA COMANDO CAMBIO	GEAR LEVER	LEVIER DE SELECTION	SCHALTPEDALHEBEL	PALANCA ACCIONAMIENTO CAMBIO	D01	16
8000B4327	SEMICUSCINETTO DI BIELLA (ROSSO)	BIG END HALF BEARING (RED)	DEMI-COUSSINET DE BIELLE (ROUGE)	PLEUEL- LAGERSCHALENHÄLFTE (ROT)	SEMICOJINETE DE BIELA (ROJO)	G02	5
8000B4347	PIASTRINA	PLATE	PLAQUETTE	BLECH	PLACA	F01	13
8000B4358	RADIATORE ACQUA	WATER COOLER	RADIATEUR D'EAU	KÜHLER	RADIADOR AGUA	G08	22
8000B4363	DISTANZIALE	SPACER	ENTRETOISE	ABSTANDHALTER	DISTANCIADOR	B03	31
8000B4366	SUPPORTO SERBATOIO BENZINA	FUEL TANK SUPPORT	SUPPORT RESERVOIR CARBURANT	BEFESTIGUNG KRAFTSTOFFTANK	SOPORTE DEPOSITO COMBUSTIBLE	F01	13
8000B4406	PROFILO DX	R. H. PROFILE	PROFIL DROIT	RECHTE PROFIL	TIRA DER.	E05	29
8000B4407	PROFILO SX	L. H. PROFILE	PROFIL GAUCHE	LINKE PROFIL	TIRA IZQ.	E05	30
8000B4416	ESTRATTORE CUSCINETTI RUOTA ANTERIORE	FRONT WHEEL BEARING EXTRACTOR	EXTRACTEUR ROULEMENTS ROUE AVANT	AUSZIEHER VORDERRADLAGER	EXTRACTOR COJINETES RUEDA DELANTERA	J01	6
8000B4417	SUPPORTO MONTAGGIO MOTORE	ENGINE ASSEMBLY SUPPORT	SUPPORT MONTAGE MOTEUR	MONTAGEBOCK MOTOR	SOPORTE MONTAJE MOTOR	J03	10
8000B4421	ATTREZZO CUSCINETTI RUOTA ANTERIORE	FRONT WHEEL BEARINGS TOOL	OUTIL ROULEMENTS ROUE AVANT	WERKZEUG VORDERRADLAGER	UTIL COJINETE RUEDA DELANTERA	J02	2
8000B4430	STAFFA	BRACKET	BRIDE	BEFESTIGUNG	BRIDA	G08	73
8000B4440	TAPPO SERBATOIO	FILLER CAP	BOUCHON DE RÉSERVOIR	TANKVERSCHLUSS	TAPÓN DEPÓSITO	D05	3
8000B4441	SERRATURA SELLA	SADDLE LOCK	SERRURE SELLE	SITZBANKSCHLOSS	CERRADURA SILLÍN	D05	4
8000B4455	STAFFA AGGANCIO SELLA	SEAT ATTACHMENT BRACKET	BRIDE ACCROCHAGE SELLE	EINHA KLÄTTCHEN SITZBANK	BRIDA ENGANCHE SILLÍN	E05	34
8000B4518	SERBATOIO ESPANSIONE	EXPANSION TANK	VASE D'EXPANSION	AUSDEHNUNGSGEFÄSS	TANQUE DE EXPANSION	G08	43
8000B4536	PROTEZIONE	PROTECTION	PROTECTION	ABDECKUNG	PROTECCION	F03	23
8000B4537	TRASMISSIONE APERTURA GASTHROTTLE OPENING	TRANSMISSION	TRANSMISSION OUVERTURE DES GAZ	GASZUG ÖFFNUNG	TRANSMISION ABERTURA GAS	D03	8
8000B4538	TRASMISSIONE CHIUSURA GAS	THROTTLE CLOSING TRANSMISSION	TRANSMISSION FERMETURE DES GAZ	GASZUG SCHLIESSEN	TRANSMISION CIERRE GAS	D03	9
8000B4568	COMMUTATORE DX	RH SWITCH	COMODO D.	RECHTER WECHSELSCHALTER	CONMUTADOR DER.	D03	16
8000B4576	WELCOME KIT	WELCOME KIT	WELCOME KIT	WELCOME KIT	WELCOME KIT	H01	4
8000B4577	WELCOME KIT	WELCOME KIT	WELCOME KIT	WELCOME KIT	WELCOME KIT	H01	4
8000B4591	PEDALE FRENO POSTERIORE	REAR BRAKE PEDAL	PEDALE FREIN ARRIERE	BREMSPEDAL HINTERRADBREMSE	PEDAL FRENO TRASERO	D02	15
8000B4593	PEDALE CAMBIO	GEAR PEDAL	PEDALE DE SELECTION	SCHALTPEDAL	PEDAL CAMBIO	D01	15
8000B4599	DECAL	DECAL	ADHESIF	AUFKLEBER	CALCOMANIA	E04	27
8000B4600	SERBATOIO BENZINA	FUEL TANK	RESERVOIR D'ESSENCE	BENZINTANK	DEPOSITO GASOLINA	E04	6
8000B4601	SERBATOIO BENZINA	FUEL TANK	RESERVOIR D'ESSENCE	BENZINTANK	DEPOSITO GASOLINA	E04	6
8000B4619	VALVOLA REGOLAZ. PRESSIONE	PRESSURE ADJUSTING VALVE	SOUPAPE REGULATRICE DE PRESSION	VENTIL DRUCKEINSTELLUNG	VALVULA REGULACION PRESION	G01	50
8000B4628	DECAL	DECAL	ADHESIF	AUFKLEBER	CALCOMANIA	B04	27
						B05	27
						B06	25
						B07	25
8000B4629	POMPA FRENO ANTERIORE	FRONT BRAKE PUMP	MAITRE-CYLINDRE FREIN AVANT	BREMSPUMPE VORDERRADBREMSE	BOMBA FRENO DELANTERO	D03	14
8000B4630	POMPA FRIZIONE	CLUTCH PUMP	MAITRE-CYLINDRE D'EMBRAYAGE	KUPPLUNGSPUMPE	BOMBA EMBRAGUE	D04	4
8000B4643	DISTANZIALE	SPACER	ENTRETOISE	ABSTANDHALTER	DISTANCIADOR	K01	9



INDICE CODICI / DENOMINAZIONI
CODEX / DESIGNATION INDEX • INDEX CODES / DÉNOMINATIONS
INHALTSVERZEICHNIS CODE • ÍNDICE CÓDIGOS / DENOMINACIONES

Code	Denominazione	Description	Désignation	Bezeichnung	Descripción	Table	N°
8000B4644	FLANGIA PORTATARGA/ CATADIOTTRI	NUMBER PLATE HOLDER/ RETROREFLECTORS FLANGE	FLASQUE SUPPORT DE PLAQUE/REFLECTEURS	BEFESTIGUNGSFLANSCH - NUMMERN SCHILD	BRIDA PORTAPLACA/ CATAFARROS	K01	8
8000B4645	CATADIOTTRO	REFLECTOR	REFLECTEUR	KATZENAUGE	CATAFARO	K01	1
8000B4652	PROTEZIONE	PROTECTION	PROTECTION	ABDECKUNG	PROTECCION	J04	12
8000B4679	BASE DI STERZO CON PERNO	STEERING BASE WITH PIN	TETE INFERIEUR AVEC AXE	LENKAUFLAGE MIT ZAPFEN	BASE DE LA DIRECCION CON PERNO	B03	3
8000B4712	DADO A GRAFFETTA	NUT	ECROU	MUTTER	TUERCA	G08	77
8000B4713	TAPPO DI SFIATO	BREATHER PLUG	BOUCHON D'EVENT	ENTLÜFTUNGSKAPPE	TAPON RESPIRADERO	G08	78
8000B4728	DISTANZIALE	SPACER	ENTRETOISE	ABSTANDHALTER	DISTANCIADOR	F01	28
8000B4738	RETROVISORE DX	RH REARVIEW MIRROR	RETROVISEUR D.	RECHTER RÜCKSPIEGEL	RETROVISOR DERECHO	E02	1
8000B4739	RETROVISORE SX	LH REARVIEW MIRROR	RETROVISEUR G.	LINKER RÜCKSPIEGEL	RETROVISOR IZQUIERDO	E02	2
8000B4740	ANTIVIBRANTE	VIBRATION-DAMPER	ANTI-VIBRATIONS	SCHWINGUNGSDÄMPFER	ANTIVIBRANTE	F01	27
8000B4744	PROIETTORE ANTERIORE	HEADLIGHT	PROJECTEUR AVANT	SCHWEINWERFER	PROYECTOR DELANTERO	F02	1
8000B4745	SELLA	SADDLE	SELLE	SITZ	SILLIN	E05	19
8000B4767	CENTRALINA INIEZIONE	INJECTION POWER UNIT	BOITIER DE CONTR. INIECTION	EINSPRITZ-STEUERUNG	CENTRALITA INYECCION	F03	19
8000B4770	TELAJETTO POSTERIORE	REAR FRAME	CADRE ARRIERE	HINTERER KLEINER RAHMEN	CHASIS TRASERO	A02	1
8000B4773	GUARNIZIONE TESTA (SP. 0.40)	HEAD GASKET (THICKNESS 0.40)	JOINT DE CULASSE (EP. 0.40)	ZYLINDERKOPFDICHTUNG (STÄRKE 0.40)	JUNTA CULATA (SP. 0.40)	G03	9
8000B4784	CUSCINETTO DI STERZO	STEERING BEARING	ROULEMENT DE DIRECTION	LENKLAGER	COJINETE DE LA DIRECCION	A01	2
8000B4839	FLANGIA ALTERNATORE	ALTERNATOR FLANGE	STATOR	LICHTMASCHINENFLANSCH	BRIDA ALTERNADOR	G14	11
8000B4847	PISTONE COMPLETO	PISTON ASSEMBLY	PISTON COMPLET	KOLBEN KOMPLETT	PISTON COMPLETO	G03	2
8000B4849	GRUPPO SEGMENTI PISTONE	PISTON RING ASSEMBLY	GROUPE SEGMENTS PISTON	BAUGRUPPE KOLBENRINGE	CONJUNTO AROS DEL PISTON	G03	3
8000B4853	SPINOTTO	PISTON PIN	AXE DE PISTON	KOLBENBOLZEN	PERNO DEL PISTON	G03	4
8000B4854	ANELLO ELASTICO	SNAP RING	CIRCLIP	SPRENGRING	ARO	G03	5
8000B4855	MOTORE COMPLETO	ENGINE ASSEMBLY	MOTEUR COMPLET	MOTOR KOMPLETT	MOTOR COMPLETO	G01	55
8000B4864	PISTONE COMPLETO	PISTON ASSEMBLY	PISTON COMPLET	KOLBEN KOMPLETT	PISTON COMPLETO	G03	2
8000B4865	GRUPPO SEGMENTI PISTONE	PISTON RING ASSEMBLY	GROUPE SEGMENTS PISTON	BAUGRUPPE KOLBENRINGE	CONJUNTO AROS DEL PISTON	G03	3
8000B4872	ALTERNATORE	ALTERNATOR	ALTERNATEUR	LICHTMASCHINE	ALTERNADOR	G15	8
8000B4902	SENSORE MARCE	GEAR SENSOR	CAPTEUR POSITION BOÎTE DE VIT.	SENSOR FÜR WECHSELGETREIBESTELLUNG	SENSOR POSICIÓN CAMBIO	G11	48
8000B4909	GRUPPO PRINCIPALE CAVI	MAIN CABLES SET	FAISCEAU PRINCIPAL	HAUPTKABELSTRANG	GRUPO CABLES PRINCIPALES	F01	14
8000B4910	TAPPO	PLUG	BOUCHON	VERSCHLUSS	TAPON	G08	49
8000B4944	SUPPORTO PROIETTORE	HEADLIGHT SUPPORT	SUPPORT DE PROJECTEUR	SCHWEINWERFER HALTERUNG	SOPORTE PROYECTOR	F01	22
8000B4948	RELÉ INTERMITTENZA	INTERMITTENCE RELAY	RELAIS CLIGNOTANTS	BLINKRELAIS	RELÉ INTERMITENCIA	F01	24
8000B4920	KIT COMANDO ALBERO ROVESCIAIO	UPSIDE-DOWN GEAR CONTROL SHAFT KIT	KIT BARILLET DE BOITE DE VITESSE A L'ENVERS	OBSERSEITE UNTENGETRIEBE STEUERWELLE BAUSATZ	KIT EJE ACCIONAMIENTO COMANDO CAMBIO AL REVES	G11	51
8000B4945	PROTEZIONE LATERALE SX RADIATORE	SIDE LH COOLER PROTECTION	PROTECTION LATERALE G. DE RADIATEUR	LINKER SEITEN- KÜHLERABDECKUNG	PROTECCION RADIADOR LATERAL IZQ.	E01	14
8000B4946	PROTEZIONE LATERALE DX RADIATORE	SIDE RH COOLER PROTECTION	PROTECTION LATERALE D. DE RADIATEUR	RECHTER SEITEN- KÜHLERABDECKUNG	PROTECCION RADIADOR LATERAL DER.	E02	12
8000B4964	CATADIOTTRO	REFLECTOR	REFLECTEUR	KATZENAUGE	CATAFARO	K01	2
8000B4969	FLANGIA PORTATARGA/ CATADIOTTRI	NUMBER PLATE HOLDER/ RETROREFLECTORS FLANGE	FLASQUE SUPPORT DE PLAQUE/REFLECTEURS	BEFESTIGUNGSFLANSCH - NUMMERN SCHILD	BRIDA PORTAPLACA/ CATAFARROS	K01	8
8000B4982	DECAL	DECAL	ADHESIF	AUFKLEBER	CALCOMANIA	B03	13
8000B5021	DISTANZIALE	SPACER	ENTRETOISE	ABSTANDHALTER	DISTANCIADOR	K01	27
8000B5024	ALBERO A CAMME (SCARICO)	CAMSHAFT (EXHAUST)	ARBRE A CAMES (ECH.)	NOCKENWELLE (AUSLASS)	ARBOL DE LEVAS (ESCAPE)	G05	7
8000B5027	BASAMENTO COMPLETO	ENGINE BLOCK ASSEMBLY	CARTER MOTEUR COMPLET	KURBELGEHÄUSE KOMPLETT	BASE COMPLETA	G01	1
8000B5169	TRASMISSIONE APERTURA	GASTHROTTLE OPENING TRANSMISSION	TRANSMISSION OUVERTURE DES GAZ	GASZUG ÖFFNUNG	TRANSMISION ABERTURA GAS	D03	8
8000B5170	TRASMISSIONE CHIUSURA GAS	THROTTLE CLOSING TRANSMISSION	TRANSMISSION FERMETURE DES GAZ	GASZUG SCHLIESSEN	TRANSMISION CIERRE GAS	D03	9
8000B5172	INDICATORE DIREZIONE	TURN SIGNAL	INDICATEUR DIRECTION	BLINKER	INTERMITENTE	F01	25
						F06	15
8000B5173	INDICATORE DIREZIONE	TURN SIGNAL	INDICATEUR DIRECTION	BLINKER	INTERMITENTE	F01	26
						F06	12

INDICE CODICI / DENOMINAZIONI

 CODEX / DESIGNATION INDEX • INDEX CODES / DÉNOMINATIONS
 INHALTSVERZEICHNIS CODE • ÍNDICE CÓDIGOS / DENOMINACIONES

Code	Denominazione	Description	Désignation	Bezeichnung	Descripción	Table	N°
8000B5205	PIASTRINA	PLATE	PLAQUETTE	BLECH	PLACA	F01	16
8000B5244	TARGHETTA "RUMORE"	"NOISE" DATA PLATE	PLAQUETTE "BRUIT"	SCHILD "GERÄUSCHBELASTUNG"	ETIQUETA "RUIDOS"	K01	7
8000B5245	TARGHETTA "EMISSIONI"	"EMISSIONS" DATA PLATE	PLAQUETTE "EMISSIONS"	SCHILD "ABGASWERTE"	ETIQUETA "EMISIONES"	K01	6
8000B5278	UGELLO OLIO PISTONE	PISTON OIL NOZZLE	TUYERE D'HUILE DE PISTON	ÖLDUSE FÜR KOLBEN	TUBO DEL ACEITE PARA PISTON	G01	63
8000B5299	SUPPORTO	SUPPORT	SUPPORT	HALTERUNG	SOPORTE	F01	5
8000B5301	GRAFFETTA	CLIP	AGRAPHÉ	KLAMMER	GRAPA	F01	32
8000B5319	COPRICATENA SUPERIORE	UPPER CHAIN COVER	CARTER DE CHAÎNE SUPERIEUR	OBERER KETTENSCHUTZ	CUBRECADENA SUPERIOR	B01	22
8000B5421	STAFFA SUPPORTO CATADIOTTRO	REFLECTOR SUPPORT	SUPPORT REFLECTEUR	KATZENHAUGEHALTERUNG	BRIDA SOPORTE CATAFARO	K01	29
8000B5435	VITE M5X75	M5X75 SCREW	VIS M5X75	SCHRAUBE M5X75	TORNILLO M5X75	F01	29
8000B5437	KIT CATENA-CORONA- PIGNONE	CHAIN-RING GEAR- SPROCKET KIT	KIT CHÂÎNE-COURONNE- PIGNON	KETTEN-KRANZ-RITZEL BAUSATZ	KIT CATENA-CORONA- PIÑON	C01	35
8000B5342	FILTRO OLIO	OIL FILTER	FILTRE À HUILE	ÖLFILTER	FILTRO DE ACEITE	G06	11
8000B5544	MOLLA	SPRING	RESSORT	FEDER	MUELLE	G11	34
8000B5572	FORNITURA SERRATURE	LOCKS KIT	FOURNITURE SERRURES	BAUSATZ SCHLÖSSER	SUMINISTRO CERRADURA	D05	1
8000B5574	INTERRUTTORE ACCENSIONE	IGNITION LOCK SWITCH WITH KEYS	CONTACTEUR D'ALLUMAGE AVEC CLES	ZÜNDSCHLOSS MIT SCHLÜSSELN	INTERRUPTOR DE ENCENDIDO CON LLAVE	D05	2
8000B5575	CHIAVE GREZZA	VIRGIN IGNITION LOCK KEY	CLE BRUTE	SCHLÜSSELROHLING	LLAVE NO ACABADA	D05	5
8000B5708	CUFFIA FANALE	HEADLIGHT COVER	COIFFE POUR PHARE	SCHWEINWERFERHAUBE	PROTECCIÓN FARO	F02	5
8000B5709	CAVI PROIETTORE ANTERIORE	HEADLIGHT CABLES	CABLES DU PROJECTEUR AVANT	SCHWEINWERFERKABEL	CABLES PROYECTOR DELANTERO	F02	9
8000B5710	LAMPADA H4	H4 BULB	AMPOULE H4	LAMPE H4	LAMPARA H4	F02	3
8000B5711	LAMPADA W5W	W5W BULB	AMPOULE W5W	LAMPE W5W	LAMPARA W5W	F02	2
8000B5712	VITE M5X10	M5X10 SCREW	VIS M5X10	SCHRAUBE M5X10	TORNILLO M5X10	F02	11
8000B5713	ANELLO DI FISSAGGIO	FIXING RING	BAGUE DE FIXATION	BEFESTIGUNGSRING	ANILLO DE SUJECIÓN	F02	10
8000B5721	SPESSORE ELASTICO	ELASTIC SHIM	ÉPAISSEUR ELASTIQUE	ELASTISC H SCHEIBE	ESPEJOR ELÁSTICO	F01	31
8000B5773	PARAFANGO ANTERIORE	FRONT MUDGUARD	GARDE-BOUE AVANT	VORDERER KOTFLÜGEL	GUARDABARRO DELANTERO	E01	1
8000A5774	DECAL	DECAL	ADHESIF	AUFKLEBER	CALCOMANIA	E01	21
8000B5779	DECAL	DECAL	ADHESIF	AUFKLEBER	CALCOMANIA	E04	34
80A033552	SPURGO	DRAIN VALVE	VIS DE PURGE	ENTLÜFTUNGSSCHRAUBE	ESPURGO	D04	10
80A036137	ROSETTA	WASHER	RONDELLE	UNTERLEGSSCHEIBE	ARANDELA	G16	38
80A069148	PERNO PER SELLA	SADDLE PIN	AXE SELLE	SITZ WELLE	PERNO SILLIN	E05	21
80A082728	TAPPO	PLUG	BOUCHON	VERSCHLUSS	TAPON	D03	26
80A082753	PINZA FRENO POSTERIORE	REAR BRAKE CALIPER	ETRIER FREIN ARRIÈRE	BREMSSATTEL HINTERRADBREMSE	PINZA FRENO TRASERO	C01	20
80A084901	SPINA	PIN	GOUJON	STIFT	PERNO	C01	8
80A084902	VITE PER SPINA	PIN SCREW	VIS	SCHRAUBE FÜR STIFT	TORNILLO PARA PERNO	C01	10
80A086447	BUSSOLA	BUSH	BAGUE	HÜLSE	CASQUILLO	B02	14
80A090265	SEMIGUSCIO INFERIORE	LOWER HALF BEARING	DEMI-COQUE INFÉRIEURE	UNTERE SCHALENHÄLFTE	SEMICASCO INFERIOR	D03	3
80A090392	BUSSOLA	BUSH	BAGUE	HÜLSE	CASQUILLO	A01	8
80A090416	PERNO PEDANA	FOOTBOARD PIN	AXE CALE-PIED	FUSSRASTENBOLZEN	PERNO ESTRIBO APOYAPIE'	D01	8
						D02	8
80A090418	MOLLA	SPRING	RESSORT	FEDER	MUELLE	D01	10
						D02	10
80A090431	PERNO	PIN	AXE	ZAPFEN	PERNO	A01	17
80A090432	DADO AUTOFRENANTE M8	M8 SELF LOCKING NUT	ECROU M8 DE SÉCURITÉ	MUTTER M8, SELBSTSICHERND	TUERCA M8 DE SEGURIDAD	A01	18
						E02	6
						E02	10
80A090977	PIOLO AGGANCIAMENTO FIANCHETTO	SIDE HOOK PIN	PION FIXATION CACHE	HAKEN FÜR SEITENTEIL	ESPIGA ENGANCHE LATERAL	E04	22
80A091653	PIASTRINA	PLATE	PLAQUETTE	BLECH	PLACA	F03	4
80A091661	PEDANA SX	LH FOOTBOARD	CALE-PIED G.	LINKE FUSSRASTE	ESTRIBO IZQUIERDO	A02	24
80A091662	PEDANA DX	RH FOOTBOARD	CALE-PIED D.	RECHTE FUSSRASTE	ESTRIBO DERECHO	A02	29
80A091691	VITE PER RACCORDI IDRAULICI	HYDRAULIC UNION SCREW	VIS POUR RACCORDS HYDRAULIQUE	SCHRAUBE FÜR ANSCHLÜSSE HYDRAULIKLEITUNGEN	TORNILLO PARA CONEXION HIDRAULICA	D04	9



INDICE CODICI / DENOMINAZIONI
CODEX / DESIGNATION INDEX • INDEX CODES / DÉNOMINATIONS
INHALTSVERZEICHNIS CODE • ÍNDICE CÓDIGOS / DENOMINACIONES

Code	Denominazione	Description	Désignation	Bezeichnung	Descripción	Table	N°
80A091692	VITE PER RACCORDI IDRAULICI	HYDRAULIC UNION SCREW	VIS POUR RACCORDS HYDRAULIQUE	SCHRAUBE FÜR ANSCHLÜSSE HYDRAULIKLEITUNGEN	TORNILLO PARA CONEXION HIDRAULICA	D02 D03 D04	35 18 8
80A092658	DISTANZIALE	SPACER	ENTRETOISE	ABSTANDHALTER	DISTANCIADOR	A01	33
80A092670	BUSSOLA	BUSH	BAGUE	HÜLSE	CASQUILLO	E01 E01 E05	6 8 33
80A092894	SEMIGUSCIO SUPERIORE	UPPER HALF BEARING	DEMI-COQUE SUPERIEURE	OBERE SCHALENHÄLFTE	SEMICASCO SUPERIOR	D03	2
80A093298	LEVA FRIZIONE	CLUTCH LEVER	LEVIER D'EMBRAYAGE	KUPPLUNGSHEBEL	PALANCA EMBRAGUE	D04	13
80A093310	TAPPO	PLUG	BOUCHON	VERSCHLUSS	TAPON	D04	20
80A097086	PIASTRINA CENTRAGGIO CANISTER	CANISTER CENTERING PLATE	PLAQUETTE DE CENTRAGE DU CANISTER	CARBONKANISTER- ZENTRIERENPLATTE	PLACA PARA CENTRO CANISTER	K02	3
80A097919	VALVOLA (SCARICO)	VALVE (EXHAUST)	SOUPAPE (ECHAPPEMENT)	VENTIL (AUSLASS)	VALVULA (ESCAPE)	G04	10
80A098720	PIASTRINA	PLATE	PLAQUETTE	BLECH	PLACA	E04	32
80A098722	SERBATOIO OLIO COMPLETO	COMPLETE OIL TANK	RÉSERVOIR D'HUILE COMPLET	KOMPLETTER ÖLTANK	DEPÓSITO ACEITE COMPLETO	D03	24
80A098723	SERBATOIO OLIO COMPLETO	COMPLETE OIL TANK	RÉSERVOIR D'HUILE COMPLET	KOMPLETTER ÖLTANK	DEPÓSITO ACEITE COMPLETO	D04	18
80A098832	DECAL	DECAL	ADHESIF	AUFKLEBER	CALCOMANIA	E04	7
80A099250	TUBO RADIATORE/POMPA	RADIATOR/PUMP PIPE	CANALISATION RADIATEUR/POMPE	LEITUNG KÜHLER/ PUMPE	TUBO RADIADOR /BOMBA	G08	56
80A099276	PIASTRINA	PLATE	PLAQUETTE	BLECH	PLACA	F05	5
80A099290	MOLLA	SPRING	RESSORT	FEDER	MUELLE	K01	23
80A099373	VITE M5	M5 SCREW	VIS M5	SCHRAUBE M5	TORNILLO M5	K02	8
80A099453	PIASTRINA	PLATE	PLAQUETTE	BLECH	PLACA	G08	46
80A0A9042	SUPPORTO VALVOLA ARIA SECONDARIA	SECONDARY AIR VALVE SUPPORT	SUPPORT DU SOUPAPE DE L'AIR SECONDAIRE	SEKUNDÄRLUFTVENTIL- HALTERUNG	SOPORTE VALVULA DEL AIRE SECUNDARIO	G13	27
80A0A1356	VALVOLA (ASPIRAZIONE)	VALVE (INTAKE)	SOUPAPE (ADMISSION)	VENTIL (EINLASS)	VALVULA (ADMISION)	G04	9
80A0A3247	CORONA	GEAR	COURONNE	ZAHNKRANZ	CORONA	C01	41
80A0A3248	PERNO PER CORONA	GEAR PIN	AXE COURONNE	ZAHNKRANZWELLE	PERNO CORONA	C01	31
80A0A3469	BUSSOLA PER PERNO	BUSH FOR PIN	BAGUE POUR AXE	HÜLSE FÜR ACHSE	CASQUILLO PARA PERNO	C02 C03	8 8
80A0A3823	LEVA FRENO ANTERIORE	FRONT BRAKE LEVER	LEVIER DE FREIN AVANT	VORDERRADBREMSEHEBEL	PALANCA FRENO DELANTERO	D03	39
80A0A3886	DADO M5	M5 SPRING	ECROU M5	MUTTER M5	TUERCA M5	K01	28
80A0A5147	TAPPO	PLUG	BOUCHON	VERSCHLUSS	TAPON	G01	59
80A0A8944	SUPPORTO DX ELETTOVENTOLA	RH HEATER FAN SUPPORT	SUPPORT DROIT ELECTROVENTILATEUR	RECHTE KÜHLGEBLÄSE- HALTERUNG	SOPORTE DERECHO ELECTROVENTILADOR	G08	2
80A0A8945	SUPPORTO SX ELETTOVENTOLA	LH HEATER FAN SUPPORT	SUPPORT GAUCHE ELECTROVENTILATEUR	LINKE KÜHLGEBLÄSE- HALTERUNG	SOPORTE IZQUIERDO ELECTROVENTILADOR	G08	3
80A0B2004	COPERCHIO ALTERNATORE	ALTERNATOR COVER	COUVERCLE ALTERNATEUR	ALTERNATORDECKEL	TAPA ALTERNADOR	G01	32
80A0B2551	GRUPPO CILINDRI	CYLINDERS ASSEMBLY	GROUPE CYLINDRES	ZYLINDEREINHEIT	CONJUNTO CILINDROS	G03	1
80A0B2947	CODINO	TAIL	COQUE ARRIERE	HECKTEIL	COLA	E05	1
80A0B2951	FIANCHETTO SX SERBATOIO	FUEL TANK LH SIDE	CACHE G. RESERVOIR	LINKE TANK-SEITENVERKLEIDUNG	LATERAL IZQUIERDO DEPOSITO	E04	5
80A0B2952	FIANCHETTO DX SERBATOIO	FUEL TANK RH SIDE	CACHE D. RESERVOIR	RECHTE TANK- SEITENVERKLEIDUNG	LATERAL DERECHO DEPOSITO	E04	3
80A0B2955	RETINA FIANCHETTO SX SERBATOIO	TANK LH SIDE NET	GRILLE CACHE G. RÉSERVOIR	LINKES TANK-SEITENTEIL GITTERNETZ	REDECILLA LATERAL IZQUIERDO DEPÓSITO	E04	19
80A0B2956	RETINA FIANCHETTO DX SERBATOIO	TANK RH SIDE NET	GRILLE CACHE D. RÉSERVOIR	RECHTES TANK-SEITENTEIL GITTERNETZ	REDECILLA LATERAL DERECHO DEPÓSITO	E04	16
80A0B2957	FIANCHETTO SX AIRBOX	AIRBOX LH SIDE	CACHE G. AIRBOX	LINKES AIRBOX-SEITENTEIL	LATERAL IZQUIERDO AIRBOX	E04	35
80A0B2958	FIANCHETTO DX AIRBOX	AIRBOX RH SIDE	CACHE D. AIRBOX	RECHTES AIRBOX-SEITENTEIL	LATERAL DERECHO AIRBOX	E04	38
80A0B2961	RETINA FIANCHETTO SX AIRBOX	AIRBOX LH SIDE NET	GRILLE CACHE G. AIRBOX	LINKES AIRBOX-SEITENTEIL GITTERNETZ	REDECILLA LATERAL IZQUIERDO AIRBOX	E04	36
80A0B2962	RETINA FIANCHETTO DX AIRBOX	AIRBOX RH SIDE NET	GRILLE CACHE D. AIRBOX	RECHTES AIRBOX-SEITENTEIL GITTERNETZ	REDECILLA LATERAL DERECHO AIRBOX	E04	39
80A0B2971	SELLA PASSEGGERO	PILLION	SELLE PASSAGER	BEIFAHRERSITZ	SILLIN PASAJERO	E05	24
80A0B2993	TELAIO	CHASSIS	CADRE	RAHMEN	BASTIDOR	A01	1
80A0B3021	COPERTURA CRUSCOTTO	DASHBOARD COVER	COUVRE-COMBINE DE BORD	ARAMTURENBRETTDECKEL	TAPA TABLERO	E01	11

INDICE CODICI / DENOMINAZIONI

 CODEX / DESIGNATION INDEX • INDEX CODES / DÉNOMINATIONS
 INHALTSVERZEICHNIS CODE • ÍNDICE CÓDIGOS / DENOMINACIONES

Code	Denominazione	Description	Désignation	Bezeichnung	Descripción	Table	N°
80A0B3053	PROTEZIONE LATERALE SX RADIATORE	SIDE LH COOLER PROTECTION	PROTECTION LATERALE G. DE RADIATEUR	LINKER SEITEN-KÜHLERABDECKUNG	PROTECCION RADIADOR LATERAL IZQ.	E01	14
80A0B3054	PROTEZIONE LATERALE DX RADIATORE	SIDE RH COOLER PROTECTION	PROTECTION LATERALE D. DE RADIATEUR	RECHTER SEITEN-KÜHLERABDECKUNG	PROTECCION RADIADOR LATERAL DER.	E02	12
80A0B3092	FLANGIA SUPPORTO TUBI OLIO	OIL PIPES SUPPORT FLANGE	FLASQUE DE SUPPORT DES CANALISATIONS D'HUILE	ÖLLEITUNGSHALTERUNG-FLANSCH	BRIDA DE SOPORTE TUBOS DEL ACEITE	G01	51
80A0B3098	CERCHIO RUOTA POSTERIORE	REAR RIM	JANTE ROUE ARRIERE	HINTERRADFELGE	LLANTA RUEDA TRASERA	C01	1
80A0B3139	SERBATOIO BENZINA	FUEL TANK	RESERVOIR D'ESSENCE	BENZINTANK	DEPOSITO GASOLINA	E04	6
80A0B3140	SERBATOIO BENZINA	FUEL TANK	RESERVOIR D'ESSENCE	BENZINTANK	DEPOSITO GASOLINA	E04	6
80A0B3163	CERCHIO RUOTA ANTERIORE	FRONT RIM	JANTE ROUE AVANT	VORDERRADFELGE	LLANTA RUEDA DELANTERA	C02	1
80A0B3202	DECAL	DECAL	ADHESIF	AUFKLEBER	CALCOMANIA	E04	27
80A0B3213	FIANCHETTO SX CODINO	TAIL LH SIDE FAIRING	CACHE G. COQUE ARRIERE	LINKE HECKTEIL-VERKLEIDUNG	LATERAL IZQUIERDO COLA	E05	5
80A0B3214	FIANCHETTO DX CODINO	TAIL RH SIDE FAIRING	CACHE D. COQUE ARRIERE	RECHTE HECKTEIL-VERKLEIDUNG	LATERAL DERECHO COLA	E05	14
80A0B3215	DECAL	DECAL	ADHESIF	AUFKLEBER	CALCOMANIA	E05	6
						E05	15
80A0B3290	COPERCHIO RUOTA FONICA	PHONIC WHEEL COVER	COUVERCLE ROUE PHONIQUE	SENSOR RADDREHUNG DECKEL	TAPA RUEDA FONICA	G01	40
80A0B3291	COPPA OLIO	OIL PAN	CARTER D'HUILE	ÖLWANNE	CARTER ACEITE	G01	43
80A0B3340	BASE DI STERZO CON PERNO	STEERING BASE WITH PIN	TETE INFERIEUR AVEC AXE	LENKAUFLAGE MIT ZAPFEN	BASE DE LA DIRECCION CON PERNO	B03	3
80A0B3345	PROTEZIONE SERBATOIO	FUEL TANK PROTECTION	PROTECTION DERESERVOIR	BENZINTANK ABDECKUNG	PROTECCION PARA DEPOSITO	E04	14
80A0B3347	CERCHIO RUOTA POSTERIORE	REAR RIM	JANTE ROUE ARRIERE	HINTERRADFELGE	LLANTA RUEDA TRASERA	C01	1
80A0B3381	SUPPORTO PROIETTORE	HEADLIGHT SUPPORT	SUPPORT DE PROJECTEUR	SCHEINWERFER HALTERUNG	SOPORTE PROYECTOR	F01	22
80A0B3383	SERBATOIO BENZINA	FUEL TANK	RESERVOIR D'ESSENCE	BENZINTANK	DEPOSITO GASOLINA	E04	6
80A0B3384	SERBATOIO BENZINA	FUEL TANK	RESERVOIR D'ESSENCE	BENZINTANK	DEPOSITO GASOLINA	E04	6
80A0B3386	FIANCHETTO DX CODINO	TAIL RH SIDE FAIRING	CACHE D. COQUE ARRIERE	RECHTE HECKTEIL-VERKLEIDUNG	LATERAL DERECHO COLA	E05	14
80A0B3387	FIANCHETTO SX CODINO	TAIL LH SIDE FAIRING	CACHE G. COQUE ARRIERE	LINKE HECKTEIL-VERKLEIDUNG	LATERAL IZQUIERDO COLA	E05	5
80A0B3403	GRUPPO CILINDRI	CYLINDERS ASSEMBLY	GROUPE CYLINDRES	ZYLINDEREINHEIT	CONJUNTO CILINDROS	G03	1
80A0B3498	COLLETTORE ENTRATAACQUA	WATER INLET MANIFOLD	COLLECTEUR ENTREE D'EAU	WASSERFÄNGER	COLECTOR ENTRADA AGUA	G08	71
80A0B3518	DECAL	DECAL	ADHESIF	AUFKLEBER	CALCOMANIA	E04	27
80A0B3520	PARAFANGO ANTERIORE	FRONT MUDGUARD	GARDE-BOUE AVANT	VORDERER KOTFLÜGEL	GUARDABARRO DELANTERO	E01	1
80A0B3972	PARAFANGO ANTERIORE	FRONT MUDGUARD	GARDE-BOUE AVANT	VORDERER KOTFLÜGEL	GUARDABARRO DELANTERO	E01	1
80A0B3976	PIASTRA DX TELAIO	CHASSIS RH PLATE	PLAQUE D. CADRE	RECHTE RAHMENPLATTE	PLACA DERECHA BASTIDOR	A01	6
80A0B3977	PIASTRA SX TELAIO	CHASSIS LH PLATE	PLAQUE G. CADRE	LINKE RAHMENPLATTE	PLACA IZQUIERDA BASTIDOR	A01	5
80A0B4029	DECAL	DECAL	ADHESIF	AUFKLEBER	CALCOMANIA	E04	40
80A0B4030	DECAL	DECAL	ADHESIF	AUFKLEBER	CALCOMANIA	E05	31
80A0B4031	DECAL	DECAL	ADHESIF	AUFKLEBER	CALCOMANIA	E01	20
80A0B4196	COPERCHIO CATENA	CHAIN COVER	COUVERCLE DE CHAINE	KETTENSCHUTZ	TAPA CADENA	G11	41
80A0B4517	TUBO RADIATORE/POMPA	RADIATOR/PUMP PIPE	CANALISATION RADIATEUR/POMPE	LEITUNG KÜHLER/ PUMPE	TUBO RADIADOR /BOMBA	G08	56
80A0B4599	DECAL	DECAL	ADHESIF	AUFKLEBER	CALCOMANIA	E04	27
80A0B4600	SERBATOIO BENZINA	FUEL TANK	RESERVOIR D'ESSENCE	BENZINTANK	DEPOSITO GASOLINA	E04	6
80A0B4601	SERBATOIO BENZINA	FUEL TANK	RESERVOIR D'ESSENCE	BENZINTANK	DEPOSITO GASOLINA	E04	6
80A0B4679	BASE DI STERZO CON PERNO	STEERING BASE WITH PIN	TETE INFERIEUR AVEC AXE	LENKAUFLAGE MIT ZAPFEN	BASE DE LA DIRECCION CON PERNO	B03	3
80A0B4763	GRUPPO CILINDRI	CYLINDERS ASSEMBLY	GROUPE CYLINDRES	ZYLINDEREINHEIT	CONJUNTO CILINDROS	G03	1
80A0B4964	CATADIOTTRO	REFLECTOR	REFLECTEUR	KATZENAUGE	CATAFARO	K01	1
80A0B5295	COPERCHIO FILTRO	AIR CLEANER COVER	COUVERCLE FILTRE À AIR	LUFTFILTERGEHÄUSE	TAPA FILTRO DE AIRE	G01	47
80B004898	ROSETTA	WASHER	RONDELLE	UNTERLEGSscheibe	ARANDELA	E05	2
						F01	15
80B073832	CATADIOTTRO	RETROREFLECTOR	REFLECTEUR	KATZENAUGE	CATAFARO	K01	11
80B090316	DECAL	DECAL	ADHESIF	AUFKLEBER	CALCOMANIA	E01	22
80B094169	SUPPORTO PEDANA POSTERIORE SX	LH REAR FOOTBOARD SUPPORT	SUPPORT DE CALE-PIED ARRIERE G.	HALTERUNG HINTERE LINKE FUSSRASTE	SOPORTE ESTRIBO TRASERO IZQUIERDO	A02	21
80B098721	SUPPORTO PEDANA POSTERIORE DX	RH REAR FOOTBOARD SUPPORT	SUPPORT DE CALE-PIED ARRIERE D.	HALTERUNG HINTERE RECHTE FUSSRASTE	SOPORTE ESTRIBO TRASERO DERECHO	A02	28

INDICE CODICI / DENOMINAZIONI

CODEX / DESIGNATION INDEX • INDEX CODES / DENOMINATIONS

INHALTSVERZEICHNIS CODE • ÍNDICE CÓDIGOS / DENOMINACIONES

Code	Denominazione	Description	Désignation	Bezeichnung	Descripción	Table	N°
80B098832	DECAL	DECAL	ADHESIF	AUFKLEBER	CALCOMANIA	E04	7
80B0A3247	CORONA	GEAR	COURONNE	ZAHNKRANZ	CORONA	C01	41
80B0A4425	CONTRAPPESO	COUNTERWEIGHT	CONTREPOIDS	GEGENGEWICHT	CONTRAPESO	D03	11
						D04	1
80B0B1623	COPERCHIO TERMOSTATO	THERMOSTAT COVER	COUVERCLE DU THERMOSTAT	THERMOSTATDECKEL	TAPA TERMOSTATO	G08	67
80B0B2947	CODINO	TAIL	COQUE ARRIERE	HECKTEIL	COLA	E05	1
80B0B2951	FIANCHETTO SX SERBATOIO	FUEL TANK LH SIDE	CACHE G. RESERVOIR	LINKE TANK-SEITENVERKLEIDUNG	LATERAL IZQUIERDO DEPOSITO	E04	5
80B0B2952	FIANCHETTO DX SERBATOIO	FUEL TANK RH SIDE	CACHE D. RESERVOIR	RECHTE TANK-SEITENVERKLEIDUNG	LATERAL DERECHO DEPOSITO	E04	3
80B0B2957	FIANCHETTO SX AIRBOX	AIRBOX LH SIDE	CACHE G. AIRBOX	LINKES AIRBOX-SEITENTEIL	LATERAL IZQUIERDO AIRBOX	E04	35
80B0B2958	FIANCHETTO DX AIRBOX	AIRBOX RH SIDE	CACHE D. AIRBOX	RECHTES AIRBOX-SEITENTEIL	LATERAL DERECHO AIRBOX	E04	38
80B0B2971	SELLA PASSEGGERO	PILLION	SELLE PASSAGER	BEIFAHRERSITZ	SILLIN PASAJERO	E05	24
80B0B2993	TELAIO	CHASSIS	CADRE	RAHMEN	BASTIDOR	A01	1
80B0B3053	PROTEZIONE LATERALE SX RADIATORE	SIDE LH COOLER PROTECTION	PROTECTION LATERALE G. DE RADIATEUR	LINKER SEITEN-KÜHLERABDECKUNG	PROTECCION RADIADOR LATERAL IZQ.	E01	14
80B0B3054	PROTEZIONE LATERALE DX RADIATORE	SIDE RH COOLER PROTECTION	PROTECTION LATERALE D. DE RADIATEUR	RECHTER SEITEN-KÜHLERABDECKUNG	PROTECCION RADIADOR LATERAL DER.	E02	12
80B0B3098	CERCHIO RUOTA POSTERIORE	REAR RIM	JANTE ROUE ARRIERE	HINTERRADFELGE	LLANTA RUEDA TRASERA	C01	1
80B0B3139	SERBATOIO BENZINA	FUEL TANK	RESERVOIR D'ESSENCE	BENZINTANK	DEPOSITO GASOLINA	E04	6
80B0B3140	SERBATOIO BENZINA	FUEL TANK	RESERVOIR D'ESSENCE	BENZINTANK	DEPOSITO GASOLINA	E04	6
80B0B3202	DECAL	DECAL	ADHESIF	AUFKLEBER	CALCOMANIA	E04	27
80B0B3213	FIANCHETTO SX CODINO	TAIL LH SIDE FAIRING	CACHE G. COQUE ARRIERE	LINKE HECKTEIL-VERKLEIDUNG	LATERAL IZQUIERDO COLA	E05	5
80B0B3214	FIANCHETTO DX CODINO	TAIL RH SIDE FAIRING	CACHE D. COQUE ARRIERE	RECHTE HECKTEIL-VERKLEIDUNG	LATERAL DERECHO COLA	E05	14
80B0B3215	DECAL	DECAL	ADHESIF	AUFKLEBER	CALCOMANIA	E05	6
						E05	15
80B0B3345	PROTEZIONE SERBATOIO	FUEL TANK PROTECTION	PROTECTION DERESERVOIR	BENZINTANK ABDECKUNG	PROTECCION PARA DEPOSITO	E04	14
80B0B3383	SERBATOIO BENZINA	FUEL TANK	RESERVOIR D'ESSENCE	BENZINTANK	DEPOSITO GASOLINA	E04	6
80B0B3384	SERBATOIO BENZINA	FUEL TANK	RESERVOIR D'ESSENCE	BENZINTANK	DEPOSITO GASOLINA	E04	6
80B0B3386	FIANCHETTO DX CODINO	TAIL RH SIDE FAIRING	CACHE D. COQUE ARRIERE	RECHTE HECKTEIL-VERKLEIDUNG	LATERAL DERECHO COLA	E05	14
80B0B3387	FIANCHETTO SX CODINO	TAIL LH SIDE FAIRING	CACHE G. COQUE ARRIERE	LINKE HECKTEIL-VERKLEIDUNG	LATERAL IZQUIERDO COLA	E05	5
80B0B3518	DECAL	DECAL	ADHESIF	AUFKLEBER	CALCOMANIA	E04	27
80B0B3520	PARAFANGO ANTERIORE	FRONT MUDGUARD	GARDE-BOUE AVANT	VORDERER KOTFLÜGEL	GUARDABARRO DELANTERO	E01	1
80B0B3972	PARAFANGO ANTERIORE	FRONT MUDGUARD	GARDE-BOUE AVANT	VORDERER KOTFLÜGEL	GUARDABARRO DELANTERO	E01	1
80B0B3976	PIASTRA DX TELAIO	CHASSIS RH PLATE	PLAQUE D. CADRE	RECHTE RAHMENPLATTE	PLACA DERECHA BASTIDOR	A01	6
80B0B3977	PIASTRA SX TELAIO	CHASSIS LH PLATE	PLAQUE G. CADRE	LINKE RAHMENPLATTE	PLACA IZQUIERDA BASTIDOR	A01	5
80B0B4029	DECAL	DECAL	ADHESIF	AUFKLEBER	CALCOMANIA	E04	40
80B0B4030	DECAL	DECAL	ADHESIF	AUFKLEBER	CALCOMANIA	E05	31
80B0B4031	DECAL	DECAL	ADHESIF	AUFKLEBER	CALCOMANIA	E01	20
80C0B2951	FIANCHETTO SX SERBATOIO	FUEL TANK LH SIDE	CACHE G. RESERVOIR	LINKE TANK-SEITENVERKLEIDUNG	LATERAL IZQUIERDO DEPOSITO	E04	5
80C0B2952	FIANCHETTO DX SERBATOIO	FUEL TANK RH SIDE	CACHE D. RESERVOIR	RECHTE TANK-SEITENVERKLEIDUNG	LATERAL DERECHO DEPOSITO	E04	3
80C0B2957	FIANCHETTO SX AIRBOX	AIRBOX LH SIDE	CACHE G. AIRBOX	LINKES AIRBOX-SEITENTEIL	LATERAL IZQUIERDO AIRBOX	E04	35
80C0B2958	FIANCHETTO DX AIRBOX	AIRBOX RH SIDE	CACHE D. AIRBOX	RECHTES AIRBOX-SEITENTEIL	LATERAL DERECHO AIRBOX	E04	38
80C0B2993	TELAIO	CHASSIS	CADRE	RAHMEN	BASTIDOR	A01	1
80C0B3345	PROTEZIONE SERBATOIO	FUEL TANK PROTECTION	PROTECTION DERESERVOIR	BENZINTANK ABDECKUNG	PROTECCION PARA DEPOSITO	E04	14
80C0B3383	SERBATOIO BENZINA	FUEL TANK	RESERVOIR D'ESSENCE	BENZINTANK	DEPOSITO GASOLINA	E04	6
80C0B3384	SERBATOIO BENZINA	FUEL TANK	RESERVOIR D'ESSENCE	BENZINTANK	DEPOSITO GASOLINA	E04	6
80C0B3386	FIANCHETTO DX CODINO	TAIL RH SIDE FAIRING	CACHE D. COQUE ARRIERE	RECHTE HECKTEIL-VERKLEIDUNG	LATERAL DERECHO COLA	E05	14
80C0B3387	FIANCHETTO SX CODINO	TAIL LH SIDE FAIRING	CACHE G. COQUE ARRIERE	LINKE HECKTEIL-VERKLEIDUNG	LATERAL IZQUIERDO COLA	E05	5
80C0B3518	DECAL	DECAL	ADHESIF	AUFKLEBER	CALCOMANIA	E04	27
80C0B3520	PARAFANGO ANTERIORE	FRONT MUDGUARD	GARDE-BOUE AVANT	VORDERER KOTFLÜGEL	GUARDABARRO DELANTERO	E01	1
80C0B3946	COPERCHIO LAMELLE	BLADES COVER	COUVERCLE DES LAMES	BLÄTTERDECKEL	TAPA LÁMINAS	G04	20
80C0B4029	DECAL	DECAL	ADHESIF	AUFKLEBER	CALCOMANIA	E04	40

INDICE CODICI / DENOMINAZIONI

 CODEX / DESIGNATION INDEX • INDEX CODES / DÉNOMINATIONS
 INHALTSVERZEICHNIS CODE • ÍNDICE CÓDIGOS / DENOMINACIONES

Code	Denominazione	Description	Désignation	Bezeichnung	Descripción	Table	N°
80C0B4030	DECAL	DECAL	ADHESIF	AUFKLEBER	CALCOMANIA	E05	31
80C0B4031	DECAL	DECAL	ADHESIF	AUFKLEBER	CALCOMANIA	E01	20
80D081478	CILINDRO COMANDO FRIZIONE	CLUTCH CONTROL CYLINDER	CYLINDRE RECEPTEUR	KUPPLUNGZYLINDER	CILINDRO ACCIONAMIENTO	G09	17
80D098832	DECAL	DECAL	ADHESIF	AUFKLEBER	CALCOMANIA	E04	7
80D0B2951	FIANCHETTO SX SERBATOIO	FUEL TANK LH SIDE	CACHE G. RESERVOIR	LINKE TANK- SEITENVERKLEIDUNG	LATERAL IZQUIERDO DEPOSITO	E04	5
80D0B2952	FIANCHETTO DX SERBATOIO	FUEL TANK RH SIDE	CACHE D. RESERVOIR	RECHTE TANK- SEITENVERKLEIDUNG	LATERAL DERECHO DEPOSITO	E04	3
80D0B2953	FIANCHETTO SX SERBATOIO	FUEL TANK LH SIDE	CACHE G. RESERVOIR	LINKE TANK- SEITENVERKLEIDUNG	LATERAL IZQUIERDO DEPOSITO	E04	5
80D0B2954	FIANCHETTO DX SERBATOIO	FUEL TANK RH SIDE	CACHE D. RESERVOIR	RECHTE TANK- SEITENVERKLEIDUNG	LATERAL DERECHO DEPOSITO	E04	3
80D0B3383	SERBATOIO BENZINA	FUEL TANK	RESERVOIR D'ESSENCE	BENZINTANK	DEPOSITO GASOLINA	E04	6
80D0B3384	SERBATOIO BENZINA	FUEL TANK	RESERVOIR D'ESSENCE	BENZINTANK	DEPOSITO GASOLINA	E04	6
80D0B3518	DECAL	DECAL	ADHESIF	AUFKLEBER	CALCOMANIA	E04	27
80D0B3946	COPERCHIO LAMELLE	BLADES COVER	COUVERCLE DES LAMES	BLÄTTERDECKEL	TAPA LÁMINAS	G04	20
80D0B4030	DECAL	DECAL	ADHESIF	AUFKLEBER	CALCOMANIA	E05	31
80D0B4589	TELAIO	CHASSIS	CADRE	RAHMEN	BASTIDOR	A01	1
80D0B4845	TESTA CILINDRI COMPLETA	CYLINDER HEAD ASSEMBLY	CULASSE COMPLETE	ZYLINDERKOPF KOMPLETT	CULATA COMPLETA	G04	1
80E090316	DECAL	DECAL	ADHESIF	AUFKLEBER	CALCOMANIA	E01	22
80E098832	DECAL	DECAL	ADHESIF	AUFKLEBER	CALCOMANIA	E04	7
80E0B2951	FIANCHETTO SX SERBATOIO	FUEL TANK LH SIDE	CACHE G. RESERVOIR	LINKE TANK- SEITENVERKLEIDUNG	LATERAL IZQUIERDO DEPOSITO	E04	5
80E0B2952	FIANCHETTO DX SERBATOIO	FUEL TANK RH SIDE	CACHE D. RESERVOIR	RECHTE TANK- SEITENVERKLEIDUNG	LATERAL DERECHO DEPOSITO	E04	3
80F098832	DECAL	DECAL	ADHESIF	AUFKLEBER	CALCOMANIA	E04	7
80G090316	DECAL	DECAL	ADHESIF	AUFKLEBER	CALCOMANIA	E01	22
80G0B2963	FIANCHETTO SX CODINO	TAIL LH SIDE FAIRING	CACHE G. COQUE ARRIERE	LINKE HECKTEIL- VERKLEIDUNG	LATERAL IZQUIERDO COLA	E05	5
80G0B2964	FIANCHETTO DX CODINO	TAIL RH SIDE FAIRING	CACHE D. COQUE ARRIERE	RECHTE HECKTEIL- VERKLEIDUNG	LATERAL DERECHO COLA	E05	14
80H098832	DECAL	DECAL	ADHESIF	AUFKLEBER	CALCOMANIA	E04	7
80H0B2963	FIANCHETTO SX CODINO	TAIL LH SIDE FAIRING	CACHE G. COQUE ARRIERE	LINKE HECKTEIL- VERKLEIDUNG	LATERAL IZQUIERDO COLA	E05	5
80H0B2964	FIANCHETTO DX CODINO	TAIL RH SIDE FAIRING	CACHE D. COQUE ARRIERE	RECHTE HECKTEIL- VERKLEIDUNG	LATERAL DERECHO COLA	E05	14
80J098832	DECAL	DECAL	ADHESIF	AUFKLEBER	CALCOMANIA	E04	7
8A0021774	CUSCINETTO	BEARING	ROULEMENT	LAGER	COJINETE	G11	12
8A0023108	ANELLO DI TENUTA	GROMMET	BAGUE D'ETANCHEITE	DICHTUNGSRING	RETEN	G06	13
8A0023111	ANELLO DI TENUTA	GROMMET	BAGUE D'ETANCHEITE	DICHTUNGSRING	RETEN	G01	52
8A0023114	ANELLO DI TENUTA	GROMMET	BAGUE D'ETANCHEITE	DICHTUNGSRING	RETEN	E03	19
8A0023116	ANELLO DI TENUTA	GROMMET	BAGUE D'ETANCHEITE	DICHTUNGSRING	RETEN	G06	5
						K02	9
8A0023120	ANELLO DI TENUTA	GROMMET	BAGUE D'ETANCHEITE	DICHTUNGSRING	RETEN	G01	60
8A0026846	CUSCINETTO RADIALE	RADIAL BEARING	PALIER RADIAL	RADIALLAGER	COJINETE RADIAL	C02	2
						C03	2
8A0028855	ANELLO DI TENUTA	GROMMET	BAGUE D'ETANCHEITE	DICHTUNGSRING	RETEN	G11	37
8A0031106	ANELLO DI TENUTA	GROMMET	BAGUE D'ETANCHEITE	DICHTUNGSRING	RETEN	G01	62
8A0034323	ANELLO DI TENUTA	GROMMET	BAGUE D'ETANCHEITE	DICHTUNGSRING	RETEN	G06	3
8A0036022	ROSETTA	WASHER	RONDELLE	UNTERLEGSCHIBE	ARANDELA	G11	11
8A0042700	ANELLO DI TENUTA	GROMMET	BAGUE D'ETANCHEITE	DICHTUNGSRING	RETEN	G11	49
8A0051549	BOCCOLA	BUSH	DOUILLE	BUCHSE	CASQUILLO	G01	10
8A0065795	CUSCINETTO	BEARING	ROULEMENT	LAGER	COJINETE	G14	9
8A0081228	GUIDA VALVOLA	VALVE GUIDE	GUIDE DE SOUPAPE	VENTILFÜHRUNG	GUIA VALVULA	G04	3
8A0081316	SEMICUSCINETTO DI BANCO (BLU)	CRANKSHAFT HALF BEARING (BLUE)	DEMI-COUSSINET DE PALIER (BLEU)	KURBELWELLEN- LAGERHÄLFTE (BLAU)	SEMICOJINETE PRINCIPAL (AZUL)	G01	28
8A0081317	SEMICUSCINETTO DI BANCO (BLU)	CRANKSHAFT HALF BEARING (BLUE)	DEMI-COUSSINET DE PALIER (BLEU)	KURBELWELLEN- L LAGERHÄLFTE (BLAU)	SEMICOJINETE PRINCIPAL (AZUL)	G01	27

INDICE CODICI / DENOMINAZIONI

CODEX / DESIGNATION INDEX • INDEX CODES / DÉNOMINATIONS

INHALTSVERZEICHNIS CODE • ÍNDICE CÓDIGOS / DENOMINACIONES

Code	Denominazione	Description	Désignation	Bezeichnung	Descripción	Table	N°
8A0084182	PASTIGLIA REGOLAZIONE GIOCO (SP.1.65)	CLEARANCE ADJUSTING PAD (THICKNESS 1.65)	PASTILLE DE CALAGE (EP.1.65)	EINSTELLPLÄTTCHEN VENTILSPIEL (STÄRKE 1.65)	PASTILLA REGULACION JUEGO (SP.1.65)	G05	8
8A0090901	VITE M4X13,7	M4X13,7 SCREW	VIS M4X13,7	SCHRAUBE M4X13,7	TORNILLO M4X13,7	B01	34
						E01	9
						E01	16
						E02	14
						G08	14
						G08	18
8A0090944	TAPPO	PLUG	BOUCHON	VERSCHLUSS	TAPON	G08	48
8A0091037	TUBO IN GOMMA	HOSE	DURIT	GUMMISCHLAUCH	TUBO DE GOMA	G13	11
						K02	16
8A0094186	TUBO CARICAMENTO RADIATORE	RADIATOR FILLING PIPE	CANALISATION DE REMPLISSAGE RADIATEUR	ZULEITUNG KÜHLER	TUBO CARGA RADIADOR	G08	60
8A0094792	ATTREZZO MONTAGGIO CAMBIO	CHANGE GEAR ASSEMBLY TOOL	OUTIL MONTAGE BOITE DE VITESSES	WERKZEUG GETRIEBEMONTAGE	UTIL MONTAJE CAMBIO	J03	1
8A0096598	CATENA DISTRIBUZIONE APERTA	OPEN TIMING CHAIN	CHAINE DISTRIBUTION OUVERTE	VENTILSTEUERKETTE OFFEN	CADENA DISTRIBUCION ABIERTA	G05	4
8A0097109	TUBO RADIATORE/POMPA	RADIATOR/PUMP PIPE	CANALISATION RADIATEUR/POMPE	LEITUNG KÜHLER/ PUMPE	TUBO RADIADOR /BOMBA	G08	57
8A0097112	ANTIVIBRANTE	VIBRATION-DAMPER	ANTI-VIBRATIONS	SCHWINGUNGSDÄMPFER	ANTIVIBRANTE	F02	8
8A0098328	SPOILER PARAFANGO ANTERIORE	FRONT MUDGUARD SPOILER	SPOILER GARDE-BOUE AVANT	SPOILER VORDERER KOTFLÜGEL	SPOILER GUARDABARROS DELANTERO	E01	3
8A0098943	SERBATOIO ESPANSIONE	EXPANSION TANK	VASE D'EXPANSION	AUSDEHNUNGSGEFÄSS	TANQUE DE EXPANSION	G08	43
8A0099120	PORTATARGA	NUMBER PLATE HOLDER	SUPPORT DE PLAQUE	NUMMERNSCHILDBEFESTIGUNG	PORTAPLACA	A02	11
8A0099289	PERNO	PIN	AXE	ZAPFEN	PERNO	K01	22
8A0099348	DISTANZIALE	SPACER	ENTRETOISE	ABSTANDHALTER	DISTANCIADOR	G16	18
8A0099351	BORSA ATTREZZI COMPLETA	TOOLS KIT	TROUSSE A OUTILS COMPLETE	WERKZEUGTASCHE KOMPLETT	BOLSA HERRAMIENTAS COMPL.	H01	8
8A0099432	PROTEZIONE RADIATORE OLIO	OIL COOLER PROTECTION	PROTECTION DE RADIATEUR D'HUILE	ÖLKÜHLER ABDECKUNG	PROTECCION RADIADOR ACEITE	G08	34
8A00A0120	CATENA DI DISTRIBUZIONE CHIUUSA	CLOSED TIMING CHAIN	CHAINE DISTRIBUTION FERMEE	VENTILSTEUERKETTE GESCHLOSSEN	CADENA DISTRIBUCION CERRADA	G05	4
8A00A0819	ANELLO DI TENUTA	GROMMET	BAGUE D'ETANCHEITE	DICHTUNGSRING	RETEN	G01	53
						G06	6
8A00A1234	ROSETTA	WASHER	RONDELLE	UNTERLEGSCHIEBE	ARANDELA	G10	31
8A00A2319	DISTANZIALE	SPACER	ENTRETOISE	ABSTANDHALTER	DISTANCIADOR	G10	33
8A00A3468	PERNO RUOTA ANTERIORE	FRONT WHEEL PIN	AXE DE ROUE AVANT	VORDERRADACHSE	PERNO RUEDA DELANTERA	C02	7
						C03	7
8A00A5200	GUARNIZIONE TESTA (SP. 0.55)	HEAD GASKET (THICKNESS 0.55)	JOINT DE CULASSE (EP. 0.55)	ZYLINDERKOPFDICHTUNG (STÄRKE 0.55)	JUNTA CULATA (SP. 0.55)	G03	9
8A00A5394	SOFTWARE DIAGNOSTICA	DIAGNOSTIC SOFTWARE	LOGICIEL DIAGNOSTIC	DIAGNOSE-SOFTWARE	SOFTWARE DIAGNOSTICA	J03	6
8A00A9036	PIASTRA SUPPORTO CENTRALINA	INJECTION POWER UNIT SUPPORT PLATE	PLAQUETTE DE SUPPORT DU BOITIER DE CONTROLE	EINSPRITZ-STEUERUNG HALTERUNGBLECH	PLACA DE SOPORTE CENTRALITA INYECCION	F03	14
8A00A9370	GUARNIZIONE TESTA (SP. 0.55)	HEAD GASKET (THICKNESS 0.55)	JOINT DE CULASSE (EP. 0.55)	ZYLINDERKOPFDICHTUNG (STÄRKE 0.55)	JUNTA CULATA (SP. 0.55)	G03	9
8A00B0976	SUPPORTO PINZA	CALIPER BRACKET	SUPPORT PINCE	BREMSSZANGEHALTERUNG	SOPORTE PINZA	C01	14
8A00B1437	CATENA	CHAIN	CHAINE	KETTE	CADENA	C01	35
8A00B1654	DISCO FRENO POSTERIORE	REAR BRAKE DISK	DISQUE FREIN ARRIÈRE	BREMSSCHEIBE HINTERRADBREMSE	DISCO FRENO TRASERO	C01	11
8A00B1958	FLANGIA INFERIORE SERBATOIO	FUEL TANK LOWER FLANGE	PLATEAU INFERIEUR DU RESERVOIR	UNTERE TANKFLANSCH	SOPORTE INFERIOR DEPOSITO	G12	1
8000B2114	SOFTWARE CENTRALINA INIEZIONE	POWER UNIT PROGRAMMING SOFTWARE	LOGICIEL BOITIER DE CONTROLE INJECTION	EINSPRITZ-STEUERUNG- SOFTWARE	SOFTWARE CENTRALITA INYECCION	J03	28
8000B2117	CAVO SERIALE	SERIAL CABLE	CABLE SERIAL	SERIALKABEL	CABLE SERIAL	J03	30
8000B2118	CD-ROM SOFTWARE CENTRALINA INIEZIONE	POWER UNIT SOFTWARE CD-ROM	CD-ROM DU LOGICIEL BOITIER DE CONTROLE	CD-ROM EINSPRITZ- STEUERUNG-SOFTWARE	CD-ROM DEL SOFTWARE CENTRALITA INYECCION	J03	31
8A00B2131	STELO SX COMPLETO	LH STEM ASSEMBLY	TUBE G. COMPLET	LINKER SCHAFT KOMPLETT	VASTAGO IZQ. COMPLETO	B05	4
8A00B2132	STELO DX COMPLETO	RH STEM ASSEMBLY	TUBE D. COMPLET	RECHTER SCHAFT KOMPLETT	VASTAGO DER. COMPLETO	B04	4

INDICE CODICI / DENOMINAZIONI

 CODEX / DESIGNATION INDEX • INDEX CODES / DÉNOMINATIONS
 INHALTSVERZEICHNIS CODE • ÍNDICE CÓDIGOS / DENOMINACIONES

Code	Denominazione	Description	Désignation	Bezeichnung	Descripción	Table	N°
8A00B2672	VITE M6X12	M6X12 SCREW	VIS M6X12	SCHRAUBE M6X12	TORNILLO M6X12	A01	24
						B01	24
						E01	16
						E02	17
						E04	26
8A00B2680	VITE M5X8	M5X8 SCREW	VIS M5X8	SCHRAUBE M5X8	TORNILLO M5X8	F01	9
						F03	12
						G11	44
						K02	2
8A00B2681	VITE M6X10	M6X10 SCREW	VIS M6X10	SCHRAUBE M6X10	TORNILLO M6X10	D01	12
						D02	12
						E04	30
						E05	16
						G08	28
						G08	75
8A00B2683	VITE M8X30	M8X30 SCREW	VIS M8X30	SCHRAUBE M8X30	TORNILLO M8X30	G11	46
8A00B2684	VITE M8X50	M8X50 SCREW	VIS M8X50	SCHRAUBE M8X50	TORNILLO M8X50	G01	6
8A00B2688	VITE M6X14	M6X14 SCREW	VIS M6X14	SCHRAUBE M6X14	TORNILLO M6X14	E01	7
8A00B2690	VITE M8X20	M8X20 SCREW	VIS M8X20	SCHRAUBE M8X20	TORNILLO M8X20	C01	26
						C03	6
8A00B2778	VITE AUTOFILETTANTE	TAPPING SCREW	VIS TARAUD	BLECHSCHRAUBE	TORNILLO AUTORROSCANTE	G08	45
8A00B2802	PERNO M8X22,2	M8X22,2 PIN	AXE M8X22,2	ZAPFEN M8X22,2	PERNO M8X22,2	D02	27
8A00B2815	ROSETTA	WASHER	RONDELLE	UNTERLEGSCHEIBE	ARANDELA	G06	18
8A00B2859	TUBO	PIPE	TUYAU	LEITUNG	TUBO	J03	19
8A00B3097	Distanziale	SPACER	ENTRETOISE	ABSTANDHALTER	DISTANCIADOR	E01	19
						E02	18
8A00B3117	INDICATORE DIREZIONE POSTERIORE	REAR TURN SIGNAL	INDICATEUR DIRECTION AR.	HINTERER BLINKER	INTERMITENTE TRASERO	F06	12
						F06	15
8A00B3158	SEMIBIELLA INFERIORE	LOWER HALF SUPPORT	DEMI-BIELLE INFERIEURE	UNTERE SCHUBSTANGENHÄLFTE	SEMIBIELLA INFERIOR	B02	2
8A00B3159	DADO M12	M12 NUT	ECROU M12	MUTTER M12	TUERCA M12	B02	4
8A00B3182	TARGHETTA "RUMORE"	"NOISE" DATA PLATE	PLAQUETTE "BRUIT"	SCHILD "GERÄUSCHBELASTUNG"	ETIQUETA "RUIDOS"	K01	7
8A00B3218	CENTRALINA INIEZIONE (F)	INJECTION POWER UNIT (F)	BOITIER CONTROLE INIECTION (F)	EINSPRITZ-STEUERUNG (F)	CENTRALITA INYECCION (F)	F03	19
8A00B3344	CENTRALINA INIEZIONE (F)	INJECTION POWER UNIT (F)	BOITIER CONTROLE INIECTION (F)	EINSPRITZ-STEUERUNG (F)	CENTRALITA INYECCION (F)	F03	19
8A00B3218	CENTRALINA INIEZIONE (F)	INJECTION POWER UNIT (F)	BOITIER CONTROLE INIECTION (F)	EINSPRITZ-STEUERUNG (F)	CENTRALITA INYECCION (F)	F03	19
8A00B3381	SUPPORTO PROIETTORE	HEADLIGHT SUPPORT	SUPPORT DE PROJECTEUR	SCHWEINWERFER HALTERUNG	SOPORTE PROYECTOR	F01	22
8A00B3505	VITE	SCREW	VIS	SCHRAUBE	TORNILLO	D01	13
						D01	14
						D02	13
						D02	14
8A00B3614	FORCELLONE POSTERIORE	REAR FORK	BRAS OSCILLANT	HINTERE SCHWINGE	HORQUILLA TRASERA	B01	1
8A00B4262	TAPPO COMPLETO	PLUG ASSEMBLY	BOUCHON COMPLET	VERSCHLUSS KOMPLETT	TAPON COMPLETO	B05	22
8A00B4265	TAPPO COMPLETO	PLUG ASSEMBLY	BOUCHON COMPLET	VERSCHLUSS KOMPLETT	TAPON COMPLETO	B07	24
8A00B4327	SEMICUSCINETTO DI BIELLA (BLU)	BIG END HALF BEARING (BLUE)	DEMI-COUSSINET DI BIELLE (BLEU)	PLEVELLAGERHÄLFTE (BLAU)	SEMICOJINETE DE BIELLA (AZUL)	G02	5
8A00B4567	COMMUTATORE SX	LH SWITCH	COMODO G.	LINKER WECHSELSCHALTER	CONMUTADOR IZQUIERDO	D04	6
8A00B4728	Distanziale	SPACER	ENTRETOISE	ABSTANDHALTER	DISTANCIADOR	F01	28
8A00B4732	CODINO	TAIL	COQUE ARRIERE	HECKTEIL	COLA	E05	1
8A00B4767	CENTRALINA INIEZIONE (F)	INJECTION POWER UNIT (F)	BOITIER CONTROLE INIECTION (F)	EINSPRITZ-STEUERUNG (F)	CENTRALITA INYECCION (F)	F03	19
8A00B4773	GUARNIZIONE TESTA (SP. 0.55)	HEAD GASKET (THICKNESS 0.55)	JOINT DE CULASSE (EP. 0.55)	ZYLINDERKOPFDICHTUNG (STÄRKE 0.55)	JUNTA CULATA (SP. 0.55)	G03	9
8A00B5435	VITE M5X100	M5X100 SCREW	VIS M5X100	SCHRAUBE M5X100	TORNILLO M5X100	F01	29
8A082759	DISCO FRENO ANTERIORE	FRONT BRAKE DISK	DISQUE FREIN AV.	BREMSSCHEIBE	DISCO FRENO DELANTERO	C02	5
				VORDERRADBREMSE			

INDICE CODICI / DENOMINAZIONI

CODEX / DESIGNATION INDEX • INDEX CODES / DÉNOMINATIONS

INHALTSVERZEICHNIS CODE • ÍNDICE CÓDIGOS / DENOMINACIONES

Code	Denominazione	Description	Désignation	Bezeichnung	Descripción	Table	N°
8AA084658	VITE AUTOFILETTANTE 5X25	TAPPING SCREW	VIS TARAUD	BLECHSCHRAUBE	TORNILLO AUTORROSCANTE	E03	9
8AA084857	BUSSOLA FISSAGGIO MOTORE	ENGINE FIXING BUSH	BAGUE ANCRAGE MOTEUR	MOTOR-BEFESTIGUNGSBUCHSE	BUJE FIJACION MOTOR	A01	10
8AA091634	FASCETTA A MOLLA	SPRING CLAMP	COLLIER A RESSORT	FEDERSCHELLE	CINTA ELASTICA	G13	19
						K02	19
8AA091707	TAPPO	PLUG	BOUCHON	VERSCHLUSS	TAPON	G08	49
8AA097087	PIASTRINA FISSAGGIO CANISTER	CANISTER FIXING PLATE	PLAQUETTE DE FIXATION DU CANISTER	CARBONKANISTER-BEFESTIGUNGPLATTE	PLACA PARA FIJACION CANISTER	K02	11
8AA0B2514	GAMBA DX COMPLETA	RH LEG ASSEMBLY	BRAS D. COMPLET	RECHTES BEIN KOMPLETT	PATA HORQUILLA DER. COMPL.	B03	1
8AA0B2515	GAMBA SX COMPLETA	LH LEG ASSEMBLY	BRAS G. COMPLET	LINKES BEIN KOMPLETT	PATA HORQUILLA IZQ. COMPL.	B03	2
8AA0B3381	SUPPORTO PROIETTORE	HEADLIGHT SUPPORT	SUPPORT DE PROJECTEUR	SCHWEINWERFER HALTERUNG	SOPORTE PROYECTOR	F01	22
8AA0B3614	FORCELLONE POSTERIORE	REAR FORK	BRAS OSCILLANT	HINTERE SCHWINGE	HORQUILLA TRASERA	B01	1
8B0023109	ANELLO DI TENUTA	GROMMET	BAGUE D'ETANCHEITE	DICHTUNGSRING	RETEN	G01	61
						G08	42
8B0036022	ROSETTA	WASHER	RONDELLE	UNTERLEGSSCHEIBE	ARANDELA	G11	11
8B0081228	GUIDA VALVOLA	VALVE GUIDE	GUIDE DE SOUPAPE	VENTILFÜHRUNG	GUIA VALVULA	G04	3
8B0081316	SEMICUSCINETTO DI BANCO (GIALLO)	CRANKSHAFT HALF BEARING (YELLOW)	DEMI-COUSSINET DE PALIER (JAUNE)	KURBELWELLENLAGERHÄLFTE (GELB)	SEMICOJINETE PRINCIPAL (AMARILLO)	G01	28
8B0081317	SEMICUSCINETTO DI BANCO (GIALLO)	CRANKSHAFT HALF BEARING (YELLOW)	DEMI-COUSSINET DE PALIER (JAUNE)	KURBELWELLENLAGERHÄLFTE (GELB)	SEMICOJINETE PRINCIPAL (AMARILLO)	G01	27
8B0084182	PASTIGLIA REGOLAZIONE GIOCO (SP.1.70)	CLEARANCE ADJUSTING PAD (THICKNESS 1.70)	PASTILLE DE CALAGE (EP.1.70)	EINSTELLPLÄTTCHEN (VENTILSPIEL (STÄRKE 1.70))	PASTILLA REGULACION JUEGO (SP.1.70)	G05	8
8B0089516	CAPPUCCIO CONNETTORE DIAGNOSTICA	DIAGNOSTIC CONNECTOR CAP	CAPUCHON DU CONNECTEUR DIAGNOSTIC	DIAGNOSESTECKERKAPPE	CAPUCHON CONECTADOR DE LA DIAGNOSTICA	F03	11
8B0090279	CANNOTTO DI STERZO	STEERING TUBE	COLONNE DE DIRECTION	LENKROHR	TUBO DE LA DIRECCION	B03	7
8B0090901	VITE M4X8	M4X8 SCREW	VIS M4X8	SCHRAUBE M4X8	TORNILLO M4X8	C01	39
						E04	37
						F06	11
8B0092256	FASCETTA CLIC R	CLIC R CLAMP	COLLIER CLIC R	SCHELLE CLIC R	ABRAZADERA	E04	28
						K02	14
8B0097906	GUSCIO INFERIORE AIRBOX	AIRBOX LOWER BEARING	COQUE INFERIEURE AIRBOX	UNTERE AIRBOXSCHALEN	CASCO INFERIOR AIRBOX	E03	6
8B00A1234	ROSETTA	WASHER	RONDELLE	UNTERLEGSSCHEIBE	ARANDELA	G10	31
8B00A5200	GUARNIZIONE TESTA (SP. 0.70)	HEAD GASKET (THICKNESS 0.70)	JOINT DE CULASSE (EP. 0.70)	ZYLINDERKOPFDICHTUNG (STÄRKE 0.70)	JUNTA CULATA (SP. 0.70)	G03	9
8B00A5394	SOFTWARE DIAGNOSTICA	DIAGNOSTIC SOFTWARE	LOGICIEL DIAGNOSTIC	DIAGNOSE-SOFTWARE	SOFTWARE DIAGNOSTICA	J03	6
8B00A9370	GUARNIZIONE TESTA (SP. 0.70)	HEAD GASKET (THICKNESS 0.70)	JOINT DE CULASSE (EP. 0.70)	ZYLINDERKOPFDICHTUNG (STÄRKE 0.70)	JUNTA CULATA (SP. 0.70)	G03	9
8B00B2157	GAMBA SX COMPLETA	LH LEG ASSEMBLY	BRAS G. COMPLET	LINKES BEIN KOMPLETT	PATA HORQUILLA IZQ. COMPL.	B03	2
8B00B2158	GAMBA DX COMPLETA	RH LEG ASSEMBLY	BRAS D. COMPLET	RECHTES BEIN KOMPLETT	PATA HORQUILLA DER. COMPL.	B03	1
8B00B2159	STELO SX COMPLETO	LH STEM ASSEMBLY	TUBE G. COMPLET	LINKER SCHAFT KOMPLETT	VASTAGO IZQ. COMPLETO	B07	4
8B00B2160	STELO DX COMPLETO	RH STEM ASSEMBLY	TUBE D. COMPLET	RECHTER SCHAFT KOMPLETT	VASTAGO DER. COMPLETO	B06	4
8B00B2672	VITE M6X21	M6X21 SCREW	VIS M6X21	SCHRAUBE M6X21	TORNILLO M6X21	A02	10
						B01	14
						E05	8
						F01	10
						F06	9
						G08	38
8B00B2680	VITE M5X10	M5X10 SCREW	VIS M5X10	SCHRAUBE M5X10	TORNILLO M5X10	F06	4
						G13	16
						G16	36
8B00B2681	VITE M6X12	M6X12 SCREW	VIS M6X12	SCHRAUBE M6X12	TORNILLO M6X12	A02	15
						D02	37
						F01	12
						G16	12
8B00B2684	VITE M8X80	M8X80 SCREW	VIS M8X80	SCHRAUBE M8X80	TORNILLO M8X80	G01	5
8B00B2687	VITE M5X12	M5X12 SCREW	VIS M5X12	SCHRAUBE M5X12	TORNILLO M5X12	F01	20
						G08	50

INDICE CODICI / DENOMINAZIONI

 CODEX / DESIGNATION INDEX • INDEX CODES / DÉNOMINATIONS
 INHALTSVERZEICHNIS CODE • ÍNDICE CÓDIGOS / DENOMINACIONES

Code	Denominazione	Description	Désignation	Bezeichnung	Descripción	Table	N°
8B00B2688	VITE M6X16	M6X16 SCREW	VIS M6X16	SCHRAUBE M6X16	TORNILLO M6X16	B01	28
						B03	5
						F03	20
8B00B2690	VITE M8X22	M8X22 SCREW	VIS M8X22	SCHRAUBE M8X22	TORNILLO M8X22	A01	20
						A02	34
						D02	24
8B00B2695	VITE M6X14	M6X14 SCREW	VIS M6X14	SCHRAUBE M6X14	TORNILLO M6X14	G01	15
						G11	6
8B00B2769	PERNO	PIN	AXE	ZAPFEN	PERNO	A02	22
8B00B2807	VITE M6X8	M6X8 SCREW	VIS M6X8	SCHRAUBE M6X8	TORNILLO M6X8	G01	2
8B00B2815	ROSETTA	WASHER	RONDELLE	UNTERLEGSCHEIBE	ARANDELA	G06	23
8B00B3006	TRASMISSIONE SERRATURA	LOCK TRANSMISSION	TRANSMISSION DE SERRURE	SELZUGSCHLISSVORRICHTUNG	TRANSMISION CERRADURA	E05	12
8B00B3218	CENTRALINA INIEZIONE (JPN)	INJECTION POWER UNIT (JPN)	BOITIER DE CONTROLE INIECTION (JPN)	EINSPRITZ-STEUERUNG (JPN)	CENTRALITA INYECCION (JPN)	F03	19
8B00B3221	COLLETTORE ALIMENTAZIONE	INDUCTION MANIFOLD	COLLECTEUR ALIMENTATION	VERSORGUNGSSTUTZEN	COLECTOR ALIMENTACION	G13	1
8B00B3272	COPERCHIO TESTA	HEAD COVER	COUVRE-CULASSE	ZYLINDERKOPFDECKEL	TAPA CULATA	G04	23
8B00B3344	CENTRALINA INIEZIONE (JPN)	INJECTION POWER UNIT (JPN)	BOITIER DE CONTROLE INIECTION (JPN)	EINSPRITZ-STEUERUNG (JPN)	CENTRALITA INYECCION (JPN)	F03	19
8B00B4327	SEMICUSCINETTO DI BIELLA (GIALLO)	BIG END HALF BEARING (YELLOW)	DEMI-COUSSINET DI BIELLE (JAUNE)	PLEUELLAGERHÄLFTE (GELB)	SEMICOJINETE DE BIELA (AMARILLO)	G02	5
8BA084658	VITE AUTOFILETTANTE	TAPPING SCREW	VIS TARAUD	BLECHSCHRAUBE	TORNILLO AUTORROSCANTE	E03	7
8B00B4767	CENTRALINA INIEZIONE (JPN)	INJECTION POWER UNIT (JPN)	BOITIER DE CONTROLE INIECTION (JPN)	EINSPRITZ-STEUERUNG (JPN)	CENTRALITA INYECCION (JPN)	F03	19
8B00B4773	GUARNIZIONE TESTA (SP. 0.70)	HEAD GASKET (THICKNESS 0.70)	JOINT DE CULASSE (EP. 0.70)	ZYLINDERKOPFDICHTUNG (STÄRKE 0.70)	JUNTA CULATA (SP. 0.70)	G03	9
8C0019590	RULLINO	NEEDLE	PION	STIFT	RODILLO	G01	16
8C0036022	ROSETTA	WASHER	RONDELLE	UNTERLEGSCHEIBE	ARANDELA	G11	11
8C0057196	TAPPO	PLUG	BOUCHON	VERSCHLUSS	TAPON	G05	6
8C0069056	VITE M8X30	M8X30 SCREW	VIS M8X30	SCHRAUBE M8X30	TORNILLO M8X30	J03	13
8C0084182	PASTIGLIA REGOLAZIONE GIOCO (SP.1.75)	CLEARANCE ADJUSTING PAD (THICKNESS 1.75)	PASTILLE DE CALAGE (EP.1.75)	EINSTELLPLÄTTCHEN (STÄRKE 1.75)	PASTILLA REGULACION JUEGO (SP.1.75)	G05	8
8C0085071	VITE M6X16	M6X16 SCREW	VIS M6X16	SCHRAUBE M6X16	TORNILLO M6X16	G05	12
8C0090940	TUBO IN GOMMA	HOSE	DURIT	GUMMISCHLAUCH	TUBO DE GOMA	E04	8
						K02	4
						K02	6
8C0091037	TUBO IN GOMMA	HOSE	DURIT	GUMMISCHLAUCH	TUBO DE GOMA	G13	12
						K02	22
8C0091687	FASCETTA A VITE	SCREW CLAMP	COLLIER A VIS	SCHRAUBENSHELLE	ABRAZADERA DE ROSCA	E04	9
						K02	12
8C0092249	FASCETTA CLIC R	CLIC R CLAMP	COLLIER CLIC R	SHELLE CLIC R	ABRAZADERA	G08	40
						G08	65
8C0092465	COPERCHIO	COVER	COUVERCLE	DECKEL	TAPA	G01	3
8C0093878	CD-ROM SOFTWARE DIAGNOSTICA	DIAGNOSTIC SOFTWARE CD-ROM	CD-ROM DU POUR SOFTWARE DIAGNOSTIQUE	CD-ROM FÜR DIAGNOSE-SOFTWARE	CD-ROM PARA SOFTWARE DIAGNOSIS	J03	25
8C00B2677	VITE M6X16	M6X16 SCREW	VIS M6X16	SCHRAUBE M6X16	TORNILLO M6X16	G11	29
8C00B2680	VITE M5X12	M5X12 SCREW	VIS M5X12	SCHRAUBE M5X12	TORNILLO M5X12	E05	10
						G11	50
						G15	5
8C00B2681	VITE M6X14	M6X14 SCREW	VIS M6X14	SCHRAUBE M6X14	TORNILLO M6X14	E05	3
						G01	49
						G04	21
						G06	14
						G08	5
						G11	14
						G14	21
						K01	15

INDICE CODICI / DENOMINAZIONI

CODEX / DESIGNATION INDEX • INDEX CODES / DÉNOMINATIONS

INHALTSVERZEICHNIS CODE • ÍNDICE CÓDIGOS / DENOMINACIONES

Code	Denominazione	Description	Désignation	Bezeichnung	Descripción	Table	N°
8C00B2683	VITE M8X65	M8X65 SCREW	VIS M8X65	SCHRAUBE M8X65	TORNILLO M8X65	G11	47
8C00B2687	VITE M5X14	M5X14 SCREW	VIS M5X14	SCHRAUBE M5X14	TORNILLO M5X14	A01 D05	32 6
8C00B2690	VITE M8X25	M8X25 SCREW	VIS M8X25	SCHRAUBE M8X25	TORNILLO M8X25	A02 B03	33 12
8C00B2695	VITE M6X16	M6X16 SCREW	VIS M6X16	SCHRAUBE M6X16	TORNILLO M6X16	G01	20
8C00B4767	CENTRALINA INIEZIONE (USA)	INJECTION POWER UNIT (USA)	BOITIER DE CONTROLE INIECTION (USA)	EINSPRITZ-STEUERUNG (USA)	CENTRALITA INJECCION (USA)	F03	19
8D0081569	ROSETTA	WASHER	RONDELLE	UNTERLEGSCHEIBE	ARANDELA	G10	13
8D0084182	PASTIGLIA REGOLAZIONE GIOCO (SP.1.80)	CLEARANCE ADJUSTING PAD (THICKNESS 1.80)	PASTILLE DE CALAGE (EP.1.80)	EINSTELLPLÄTTCHEN VENTILSPIEL (STÄRKE 1.80)	PASTILLA REGULACION JUEGO (SP.1.80)	G05	8
8D0092256	FASCETTA CLIC R	CLIC R CLAMP	COLLIER CLIC R	SHELLE CLIC R	ABRAZADERA	G13	22
8D0093878	CD-ROM SOFTWARE DIAGNOSTICA	DIAGNOSTIC SOFTWARE CD-ROM	CD-ROM DU POUR SOFTWARE DIAGNOSTIQUE	CD-ROM FÜR DIAGNOSE-SOFTWARE	CD-ROM PARA SOFTWARE DIAGNOSIS	J03	25
8D0099274	FUSIBILE 7,5A	7,5A FUSE	FUSIBLE 7,5A	SICHERUNG 7,5A	FUSIBLE 7,5A	F05	18
8D00B2681	VITE M6X16	M6X16 SCREW	VIS M6X16	SCHRAUBE M6X16	TORNILLO M6X16	E04 F01 F03 G05 G06	18 17 18 20 7
8D00B2687	VITE M5X16	M5X16 SCREW	VIS M5X16	SCHRAUBE M5X16	TORNILLO M5X16	B03	29
8D00B2688	VITE M6X20	M6X20 SCREW	VIS M6X20	SCHRAUBE M6X20	TORNILLO M6X20	D01 D01 D02 G16	19 20 19 14
8D00B2690	VITE M8X30	M8X30 SCREW	VIS M8X30	SCHRAUBE M8X30	TORNILLO M8X30	A01 A02 A02 B03	37 3 30 15
8D00B2691	VITE M10X31	M10X31 SCREW	VIS M10X31	SCHRAUBE M10X31	TORNILLO M10X31	B01	20
8D00B2695	VITE M6X18	M6X18 SCREW	VIS M6X18	SCHRAUBE M6X18	TORNILLO M6X18	G13	31
8D00B5022	ALBERO A CAMME (ASP.)	CAMSHAFT (INTAKE)	ARBRE A CAMES (ADM.)	NOCKENWELLE (EINLASS)	ARBOL DE LEVAS (ADM.)	G05	5
8DA084658	VITE AUTOFILETTANTE	TAPPING SCREW	VIS TARAUD	BLECHSCHRAUBE	TORNILLO AUTORROSCANTE	E03	8
8E0062652	BUSSOLA	BUSH	BAGUE	HÜLSE	CASQUILLO	G08	9
8E0084182	PASTIGLIA REGOLAZIONE GIOCO (SP.1.85)	CLEARANCE ADJUSTING PAD (THICKNESS 1.85)	PASTILLE DE CALAGE (EP.1.85)	EINSTELLPLÄTTCHEN VENTILSPIEL (STÄRKE 1.85)	PASTILLA DE REGULACION JUEGO (SP.1.85)	G05	8
8E0092249	FASCETTA CLIC R	CLIC R CLAMP	COLLIER CLIC R	SHELLE CLIC R	ABRAZADERA	G08 G13	59 23
8E00B2680	VITE M5X16	M5X16 SCREW	VIS M5X16	SCHRAUBE M5X16	TORNILLO M5X16	E05 G13	35 35
8E00B2681	VITE M6X20	M6X20 SCREW	VIS M6X20	SCHRAUBE M6X20	TORNILLO M6X20	A01 A02 D02 G01 G01 G01 G05 G08 G08 G09 G17	9 13 32 39 42 54 15 21 68 18 16
8E00B2688	VITE M6X22	M6X22 SCREW	VIS M6X22	SCHRAUBE M6X22	TORNILLO M6X22	B03 D03	6 4
8E00B2694	VITE M5X20	M5X20 SCREW	VIS M5X20	SCHRAUBE M5X20	TORNILLO M5X20	E05	23
8E00B2695	VITE M6X20	M6X20 SCREW	VIS M6X20	SCHRAUBE M6X20	TORNILLO M6X20	G11	40

INDICE CODICI / DENOMINAZIONI

 CODEX / DESIGNATION INDEX • INDEX CODES / DÉNOMINATIONS
 INHALTSVERZEICHNIS CODE • ÍNDICE CÓDIGOS / DENOMINACIONES

Code	Denominazione	Description	Désignation	Bezeichnung	Descripción	Table	N°
8E00B3218	CENTRALINA INIEZIONE (USA)	INJECTION POWER UNIT (USA)	BOITIER DE CONTROLE INIECTION (USA)	EINSPRITZ-STEUERUNG (USA)	CENTRALITA INJECCION (USA)	F03	19
8F0032069	ROSETTA	WASHER	RONDELLE	UNTERLEGSSCHEIBE	ARANDELA	G02	15
8F0084182	PASTIGLIA REGOLAZIONE GIOCO (SP.1.90)	CLEARANCE ADJUSTING PAD (THICKNESS 1.90)	PASTILLE DE CALAGE (EP.1.90)	EINSTELLPLÄTTCHEN VENTILSPIEL (STÄRKE 1.90)	PASTILLA REGULACION JUEGO (SP.1.90)	G05	8
8F0099274	FUSIBILE 15A	15A FUSE	FUSIBLE 15A	SICHERUNG 15A	FUSIBLE 15A	F05	17
8F00B2681	VITE M6X22	M6X22 SCREW	VIS M6X22	SCHRAUBE M6X22	TORNILLO M6X22	G15 G16	11 32
8F00B2687	VITE M5X22	M5X22 SCREW	VIS M5X22	SCHRAUBE M5X22	TORNILLO M5X22	F03	5
8F00B2688	VITE M6X25	M6X25 SCREW	VIS M6X25	SCHRAUBE M6X25	TORNILLO M6X25	D03 D04	15 5
8F00B2694	VITE M5X25	M5X25 SCREW	VIS M5X25	SCHRAUBE M5X25	TORNILLO M5X25	E05	23
8F00B3344	CENTRALINA INIEZIONE (USA)	INJECTION POWER UNIT (USA)	BOITIER DE CONTROLE INIECTION (USA)	EINSPRITZ-STEUERUNG (USA)	CENTRALITA INJECCION (USA)	F03	19
8G0004551	ROSETTA	WASHER	RONDELLE	UNTERLEGSSCHEIBE	ARANDELA	G11	33
8G0084182	PASTIGLIA REGOLAZIONE GIOCO (SP.1.95)	CLEARANCE ADJUSTING PAD (THICKNESS 1.95)	PASTILLE DE CALAGE (EP.1.95)(EP.1.95)	EINSTELLPLÄTTCHEN VENTILSPIEL (STÄRKE 1.95)	PASTILLA REGULACION JUEGO (SP.1.95)	G05	8
8G0091037	TUBO IN GOMMA	HOSE	DURIT	GUMMISCHLAUCH	TUBO DE GOMA	G13	3
8G0092249	FASCETTA CLIC R	CLIC R CLAMP	COLLIER CLIC R	SHELLE CLIC R	ABRAZADERA	G08 G08	55 66
8G00B2681	VITE M6X25	M6X25 SCREW	VIS M6X25	SCHRAUBE M6X25	TORNILLO M6X25	F03 G01 G01 G05 G06 G08 G08 K01	27 8 35 23 21 10 26 12
8G00B2688	VITE M6X30	M6X30 SCREW	VIS M6X30	SCHRAUBE M6X30	TORNILLO M6X30	B03	26
8G00B2691	VITE M10X45	M10X45 SCREW	VIS M10X45	SCHRAUBE M10X45	TORNILLO M10X45	B02	7
8H0004553	ROSETTA	WASHER	RONDELLE	UNTERLEGSSCHEIBE	ARANDELA	G11	52
8H0084182	PASTIGLIA REGOLAZIONE GIOCO (SP.2.00)	CLEARANCE ADJUSTING PAD (THICKNESS 2.00)	PASTILLE DE CALAGE (EP.2.00)	EINSTELLPLÄTTCHEN VENTILSPIEL (STÄRKE 2.00)	PASTILLA REGULACION JUEGO (SP.2.00)	G05	8
8H00B2681	VITE M6X30	M6X30 SCREW	VIS M6X30	SCHRAUBE M6X30	TORNILLO M6X30	G01	46
8H00B2688	VITE M6X35	M6X35 SCREW	VIS M6X35	SCHRAUBE M6X35	TORNILLO M6X35	B03 E01 E04	30 5 25
8H00B2691	VITE M10X50	M10X50 SCREW	VIS M10X50	SCHRAUBE M10X50	TORNILLO M10X50	B02	19
8J0070266	TUBO SERBATOIO/ POMPA FRENO	FUEL TANK/BRAKE PUMP PIPE	CANALISATION RESERVOIR/ MAITRE-CYLINDRE	LEITUNG BREMSFLÜSSIGKEITS- BEHÄLTER/ BREMSPUMPE	TUBO TANQUE/ BOMBA FRENO	D02	22
8J0084182	PASTIGLIA REGOLAZIONE GIOCO (SP.2.05)	CLEARANCE ADJUSTING PAD (THICKNESS 2.05)	PASTILLE DE CALAGE (EP.2.05)	EINSTELLPLÄTTCHEN VENTILSPIEL (STÄRKE 2.05)	PASTILLA REGULACION JUEGO (SP.2.05)	G05	8
8J00B2681	VITE M6X35	M6X35 SCREW	VIS M6X35	SCHRAUBE M6X35	TORNILLO M6X35	D02 G01 G07	33 7 4
8J00B2691	VITE M10X55	M10X55 SCREW	VIS M10X55	SCHRAUBE M10X55	TORNILLO M10X55	B02	18
8K0084182	PASTIGLIA REGOLAZIONE GIOCO (SP.2.10)	CLEARANCE ADJUSTING PAD (THICKNESS 2.10)	PASTILLE DE CALAGE (EP.2.10)	EINSTELLPLÄTTCHEN VENTILSPIEL (STÄRKE 2.10)	PASTILLA REGULACION JUEGO (SP.2.10)	G05	8
8K0095276	FASCETTA CLIC	CLIC CLAMP	COLLIER CLIC	SHELLE CLIC	ABRAZADERA CLIC	G13	26
8K00B2691	VITE M10X58	M10X58 SCREW	VIS M10X58	SCHRAUBE M10X58	TORNILLO M10X58	C02 C03	16 15
8L0066179	TUBO IN GOMMA	HOSE	DURIT	GUMMISCHLAUCH	TUBO DE GOMA	G08	51
8L0084182	PASTIGLIA REGOLAZIONE GIOCO (SP.2.15)	CLEARANCE ADJUSTING PAD (THICKNESS 2.15)	PASTILLE DE CALAGE (EP.2.15)	EINSTELLPLÄTTCHEN VENTILSPIEL (STÄRKE 2.15)	PASTILLA REGULACION JUEGO (SP.2.15)	G05	8
8M0066179	TUBO IN GOMMA	HOSE	DURIT	GUMMISCHLAUCH	TUBO DE GOMA	G08	62

INDICE CODICI / DENOMINAZIONI

 CODEX / DESIGNATION INDEX • INDEX CODES / DÉNOMINATIONS
 INHALTSVERZEICHNIS CODE • ÍNDICE CÓDIGOS / DENOMINACIONES

Code	Denominazione	Description	Désignation	Bezeichnung	Descripción	Table	N°
8M0084182	PASTIGLIA REGOLAZIONE GIOCO (SP.2.20)	CLEARANCE ADJUSTING PAD (THICKNESS 2.20)	PASTILLE DE CALAGE (EP.2.20)	EINSTELLPLÄTTCHEN VENTILSPIEL (STÄRKE 2.20)	PASTILLA REGULACION JUEGO (SP.2.20)	G05	8
8M00B2681	VITE M6X50	M6X50 SCREW	VIS M6X50	SCHRAUBE M6X50	TORNILLO M6X50	G09 G17	19 17
8N0084182	PASTIGLIA REGOLAZIONE GIOCO (SP.2.25)	CLEARANCE ADJUSTING PAD (THICKNESS 2.25)	PASTILLE DE CALAGE (EP.2.25)	EINSTELLPLÄTTCHEN VENTILSPIEL (STÄRKE 2.25)	PASTILLA REGULACION JUEGO (SP.2.25)	G05	8
8P0084182	PASTIGLIA REGOLAZIONE GIOCO (SP.2.30)	CLEARANCE ADJUSTING PAD (THICKNESS 2.30)	PASTILLE DE CALAGE (EP.2.30)	EINSTELLPLÄTTCHEN VENTILSPIEL (STÄRKE 2.30)	PASTILLA REGULACION JUEGO (SP.2.30)	G05	8
8Q0092249	FASCETTA CLIC R	CLIC R CLAMP	COLLIER CLIC R	SHELLE CLIC R	ABRAZADERA	G08	61
8R0084182	PASTIGLIA REGOLAZIONE GIOCO (SP.2.35)	CLEARANCE ADJUSTING PAD (THICKNESS 2.35)	PASTILLE DE CALAGE (EP.2.35)	EINSTELLPLÄTTCHEN VENTILSPIEL (STÄRKE 2.35)	PASTILLA REGULACION JUEGO (SP.2.35)	G05	8
8S0084182	PASTIGLIA REGOLAZIONE GIOCO (SP.2.40)	CLEARANCE ADJUSTING PAD (THICKNESS 2.40)	PASTILLE DE CALAGE (EP.2.40)	EINSTELLPLÄTTCHEN VENTILSPIEL (STÄRKE 2.40)	PASTILLA REGULACION JUEGO (SP.2.40)	G05	8
8T0084182	PASTIGLIA REGOLAZIONE GIOCO (SP.2.45)	CLEARANCE ADJUSTING PAD (THICKNESS 2.45)	PASTILLE DE CALAGE (EP.2.45)	EINSTELLPLÄTTCHEN VENTILSPIEL (STÄRKE 2.45)	PASTILLA REGULACION JUEGO (SP.2.45)	G05	8
8U0084182	PASTIGLIA REGOLAZIONE GIOCO (SP.2.50)	CLEARANCE ADJUSTING PAD (THICKNESS 2.50)	PASTILLE DE CALAGE (EP.2.50)	EINSTELLPLÄTTCHEN VENTILSPIEL (STÄRKE 2.50)	PASTILLA REGULACION JUEGO (SP.2.50)	G05	8
8U0092249	FASCETTA CLIC R	CLIC R CLAMP	COLLIER CLIC R	SHELLE CLIC R	ABRAZADERA	G08	54
8V0066179	TUBO IN GOMMA	HOSE	DURIT	GUMMISCHLAUCH	TUBO DE GOMA	G08	62
8V0084182	PASTIGLIA REGOLAZIONE GIOCO (SP.2.55)	CLEARANCE ADJUSTING PAD (THICKNESS 2.55)	PASTILLE DE CALAGE (EP.2.55)	EINSTELLPLÄTTCHEN VENTILSPIEL (STÄRKE 2.55)	PASTILLA REGULACION JUEGO (SP.2.55)	G05	8
8V0092249	FASCETTA CLIC R	CLIC R CLAMP	COLLIER CLIC R	SHELLE CLIC R	ABRAZADERA	G08 G08	29 58
8W0084182	PASTIGLIA REGOLAZIONE GIOCO (SP.2.60)	CLEARANCE ADJUSTING PAD (THICKNESS 2.60)	PASTILLE DE CALAGE (EP.2.60)	EINSTELLPLÄTTCHEN VENTILSPIEL (STÄRKE 2.60)	PASTILLA REGULACION JUEGO (SP.2.60)	G05	8



A series of horizontal dotted lines for writing, spanning the width of the page.



A series of horizontal dotted lines for writing, spanning the width of the page.



MV AGUSTA Motor S.p.A. - Servizio Assistenza Tecnica
Via Giovanni Macchi, 144 - 21100 Varese (VA) ITALY
Tel. (Italia) 800.36.44.06 - (estero) ++39 0332 254.712
Fax ++39 0332 329.379 - sito web "www.mvagusta.it"
Part. N. 8000B3254 Edizione N°4