

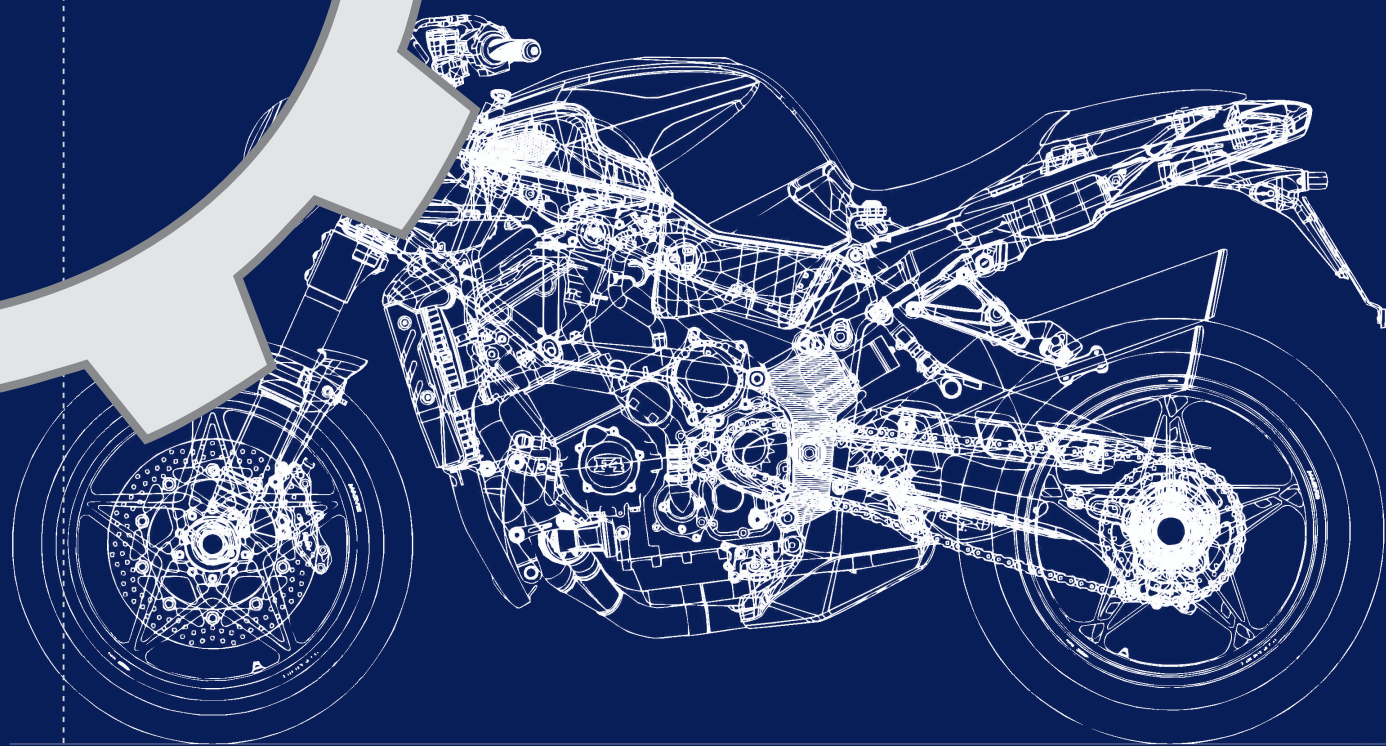

Motorcycle Art

BRUTALE



MV AGUSTA F4 BRUTALE 750 ORO-S

Catalogo ricambi

Spare parts catalogue

Catalogue des pièces détachées

Ersatzteilkatalog

Catálogo de recambios

© 2010

È vietata la riproduzione anche parziale di questo documento senza il consenso scritto della MV Agusta S.p.A.

Part. n° 800099359 - Edizione n° 6

Stampato nel Settembre 2010

INTRODUZIONE AL CATALOGO RICAMBI

INTRODUCTION TO THE SPARE PARTS CATALOGUE • INTRODUCTION AU CATALOGUE DES PIÈCES DÉTACHÉES
EINFÜHRUNG IN DEN ERSATZTEILKATALOG • INTRODUCCIÓN AL CATÁLOGO DE RECAMBIOS



SCOPO DEL CATALOGO

Questo catalogo è stato realizzato per la sola ordinazione delle parti di ricambio.

Per ottenere qualsiasi altra informazione è necessario consultare il manuale d'officina o contattare direttamente il costruttore.

PURPOSE OF THE CATALOGUE

This catalogue has been designed for spare parts ordering only.

To obtain any other information you should check the servicing manual or contact the manufacturer directly.

ZWECK DES KATALOGS

Dieser Katalog dient ausschliesslich der Bestellung von Ersatzteilen.

Für alle weiteren Informationen im technischen Handbuch nachschlagen oder direkt den Hersteller kontaktieren.

VALIDITÀ DEL CATALOGO

Le informazioni contenute in questo catalogo si riferiscono unicamente ai motocicli con numero di matricola telaio uguale o superiore a: **(ZCGF410AA3V) 000001 (Brutale ORO) o (ZCGF411AA3V) 000301 (Brutale S)**

EFFECTIVENESS OF THE CATALOGUE

The information contained in this catalogue only refers to motorcycles with a frame serial number equal or upper than **(ZCGF410AA3V) 000001 (Brutale ORO) or (ZCGF411AA3V) 000301 (Brutale S)**.

GÜLTIGKEIT DES KATALOGS

Die Informationen in dieser Katalog enthalten gelten nur für die Motorrad mit ein Rahmennummer gleich oder mehr als **(ZCGF410AA3V) 000001 (Brutale ORO) oder (ZCGF411AA3V) 000301 (Brutale S)**.

STRUTTURA DEL CATALOGO

Nell'illustrazione sono riportate alcune informazioni per interpretare il contenuto del catalogo.

CATALOGUE STRUCTURE

The picture contains some instructions on how to use the catalogue.

AUFBAU DES KATALOGS

In der Erläuterung sind einige Informationen für die richtige Interpretation des Kataloginhalts angeführt.

BUT DE CATALOGUE

Ce catalogue a été exclusivement réalisé pour commander des pièces détachées. Pour avoir toute autre information, consulter le manuel d'entretien ou bien prendre contact directement avec le constructeur.

FINALIDAD DEL CATÁLOGO

Este catálogo se ha realizado sólo para el pedido de las piezas de recambio. Para cualquier otra información es necesario consultar el manual de taller o ponerse en contacto directo con el fabricante.

VALIDITÉ DE CATALOGUE

Les informations contenu en ce catalogue se réfèrent uniquement à les motos avec un numéro de matricule du cadre égal ou supérieur à **(ZCGF410AA3V) 000001 (Brutale ORO) ou (ZCGF411AA3V) 000301 (Brutale S)**.

VALIDEZ DEL CATÁLOGO

La información en el interior de este manual corresponde solo a las motocicletas con un número de matrícula bastidor a partir de **(ZCGF410AA3V) 000001 (Brutale ORO) o (ZCGF411AA3V) 000301 (Brutale S)**.

Il contenuto del catalogo.

STRUCTURE DE CATALOGUE

L'illustration contient quelques renseignements pour mieux interpréter le contenu du catalogue.

ESTRUCTURA DEL CATÁLOGO

En la ilustración se dan algunas informaciones para interpretar el contenido del catálogo.

Numeri di riferimento, codice e quantità.

Reference numbers, code and quantity.
numéros de référence, code et quantité.
Bezugsnummern, Code und Menge.
Números de referencia, código y cantidad.

Specifiche (es: area di commercializzazione, caratteristiche costruttive, colori, note, ecc.)

Specifications (e.g. marketing area, construction characteristics, colours, notes etc.).
Specifications (par ex. zone de commercialisation, caractéristiques de construction, couleurs, notes etc.).
Spezifische Angaben (z.B. Handelsgebiet, Herstellungseigenschaften, Farben, Hinweise, usw.).
Especificaciones (ej: área de comercialización, características de fabricación, colores, notas, etc.).

Validità con riferimento matricola telaio e matricola motore.

Validity referred to frame serial number and engine serial number.
Validité concernant le matricule du châssis et le matricule du moteur.
Gültigkeit mit Bezug auf die Rahmen- und Motornummer.
Validez referida a la matrícula bastidor y matrícula motor.

N.	Code	Q.ty	Note	BRUTALE ORO	BRUTALE S	► I FRAME I ►	► I ENGINE I ►
1	800097250	1		*			
1	800097250	1			*		► I 10760
1	8000A3980	1			*		10761 ►
2	800069769	7		*	*		
3	8A0081228	16	1	*	*		
3	8B0081228	16	2	*	*		
4	800091064	2		*	*		
5	800051549	8		*	*		
6	800085071	16		*	*		
7	800065814	16		*	*		
8	800097918	8		*	*		
9	800097919	8		*	*		
10	800098670	16		*	*		
11	800098671	16		*	*		
12	800098761	16		*	*		
12	800098761	16		*	*		► I 10760
12	8000A3732	16		*	*		10761 ►

Modelli motocicletta.
Motorcycle models.
Modèles de moto.
Motorradmodelle.
Modelos motocicleta.

Numero di tavola e di edizione.

Plate and edition number.
Numéro de planche et d'édition.
Tafelnummer und Nummer der Ausgabe.
Número de tabla y de edición.

Note a piè di pagina.

Footnotes.
Notes au bas de la page.
Fussnoten.
Notas al pie de la página.

Numero di tabella e di edizione.

Table and edition number.
Numéro de tableau et d'édition.
Tabellenummer und Nummer der Ausgabe.
Número de ilustración y de edición.



INTRODUZIONE AL CATALOGO RICAMBI

INTRODUCTION TO THE SPARE PARTS CATALOGUE • INTRODUCTION AU CATALOGUE DES PIÈCES DÉTACHÉES
EINFÜHRUNG IN DEN ERSATZTEILKATALOG • INTRODUCCIÓN AL CATÁLOGO DE RECAMBIOS

SIMBOLI E ABBREVIAZIONI

- ▶ **I** Validità fino alla matricola **F USA** ...Valido solo per versione Francia, USA... **A B** ...Codice colore ≠ ...Spessore
- ▶ Validità dalla matricola **1 2** ...Note a piè pagina

SYMBOLS AND ABBREVIATIONS

- ▶ **I** Validity up to serial number
- ▶ Validity from serial number
- F USA** ...Valid for (France, Usa ...) version only
- 1 2** ...Footnotes
- A B** ...Colour code ≠ Thickness

SYMBOLS UND ABBÜRZUNGEN

- ▶ **I** Gültig ab der Kennnummer
- ▶ Gültig bis zur Kennnummer
- F USA** ...Gilt nur die Ausführung für Frankreich, die USA...
- 1 2** ...Fussnoten
- A B** ...Farbcode ≠ Stärke

SYMBOLS ET ABRÉVIATIONS

- ▶ **I** Validité jusqu'au matricule
- ▶ Validité à partir du matricule
- F USA** ...Valable uniquement pour la variante France, Usa, etc.
- 1 2** ...Notes au bas de la page
- A B** ...Code couleur ≠ Épaisseur

SÍMBOLOS Y ABBREVIACIONES

- ▶ **I** Validez hasta la matrícula
- ▶ Validez a partir de la matrícula
- F USA** ...Válido sólo para los modelos Francia, USA, ...
- 1 2** ...Notas al pie de la página
- A B** ...Código color ≠ Grosor

- A** Versione Rossa - Red version - Version Rouge - Rote Version - Version Roja. **C** Versione Argento - Silver version - Version Argent - Silber Version - Versión Plata.
- B** Versione Nera-Black version-Version Noire-Schwarze Version-Version Negra. **D** Versione Rosso/Nera-Red/Black version-VersionRouge/Noire-Rot/Schwarze Version-Version Rojo/Negra.

COME CONSULTARE IL CATALOGO RICAMBI

- 1) Identificare la parte di interesse e relativo numero di tavola.
- 2) Rintracciare la tavola all'interno del catalogo.
- 3) Identificare la parte ed il relativo numero di riferimento all'interno della tavola esplosa.

- 4) Identificare il numero di codice della parte in base al numero di riferimento e al modello di motocicletta.
- 5) Controllare la presenza di note e validità.

HOW TO CHECK THE SPARE PARTS CATALOGUE

- 1) Locate your part of interest and the relevant plate number.
- 2) Find the plate in the catalogue.
- 3) Locate the part and the corresponding reference number within the exploded view plate.
- 4) Locate the part code number according to the reference number and the motorcycle model.
- 5) Check any footnotes and validity information.

COMMENT CONSULTER LE CATALOGUE DES PIÈCES DÉTACHÉES

- 1) Identifier la pièce qui vous intéresse et le numéro de planche correspondant.
- 2) Repérer la planche à l'intérieur du catalogue.
- 3) Identifier la pièce et le numéro de référence correspondant à l'intérieur de la planche éclatée.
- 4) Identifier le code de la pièce sur la base du numéro de référence et du modèle de moto.
- 5) Contrôler la présence de notes et la validité.

NACHSCHLAGEN IM ERSATZTEILKATALOG

- 1) Das gewünschte Ersatzteil und die entsprechende Tafel feststellen.
- 2) Die Tafel im Katalog suchen.
- 3) Das Teil und die dazugehörige Bezugsnummer auf der Explosions-tafel suchen.
- 4) Aufgrund der Bezugsnummer und des Motorradmodells den Code des Ersatzteils bestimmen.
- 5) Kontrollieren, ob Hinweise oder Angaben zur Gültigkeit angeführt sind.

COMO CONSULTAR EL CATALOGO DE RECAMBIOS

- 1) Identificar la parte que interesa y el correspondiente número de tabla.
- 2) Buscar la tabla en el interior del catálogo.
- 3) Identificar la pieza y el correspondiente número de referencia en el interior de la tabla de despiece.
- 4) Identificar el número de código de la pieza en función del número de referencia y del modelo de la motocicleta.
- 5) Controlar si hay notas y la validez.

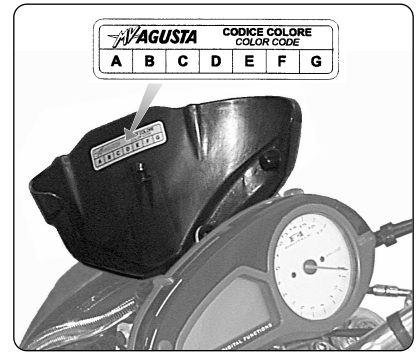

Le misure sono espresse in mm.
Measures are expressed in mm.
Les mesures sont exprimées en mm.
Die Masse sind in mm angegeben.
Las medidas están expresadas en mm.

Indice figurativo.
Figurative index.
Index figuratif.
Bildverzeichnis.
Índice de figuras.

INTRODUZIONE AL CATALOGO RICAMBI

INTRODUCTION TO THE SPARE PARTS CATALOGUE • INTRODUCTION AU CATALOGUE DES PIÈCES DÉTACHÉES
EINFÜHRUNG IN DEN ERSATZTEILKATALOG • INTRODUCCIÓN AL CATÁLOGO DE RECAMBIOS



COME ORDINARE LE PARTI DI RICAMBIO

Nel modulo di ordinazione riportare:

- 1 Il numero di codice della parte
- 2 La quantità richiesta
- 3 Il modello di motocicletta
- 4 Il numero di telaio

HOW TO ORDER SPARE PARTS

In the order form quote:

- 1 The part code number
- 2 Your required amount
- 3 The motorcycle model
- 4 The frame number

BESTELLUNG VON ERSATZTEILEN

In das Bestellformular sind einzutragen:

- 1 Der Code des Ersatzteils
- 2 Die gewünschte Anzahl
- 3 Das Motorradmodell
- 4 Die Rahmennummer

COMMENT COMMANDER LES PIÈCES DÉTACHÉES

Dans le formulaire de commande spécifier:

- 1 Le numéro de code de la pièce
- 2 La quantité voulue
- 3 Le modèle de moto
- 4 Le numéro de cadre

CÓMO PEDIR LAS PIEZAS DE RECAMBIO

Indicar en el impreso de pedido:

- 1 El número de código de la pieza
- 2 La cantidad solicitada
- 3 El modelo de motocicleta
- 4 El número de bastidor

FAC SIMILE SCHEDA DI ORDINAZIONE
ORDER FORM FACSIMILE
FAC-SIMILE DE LA FICHE DE COMMANDE
FAKSIMILE DES BESTELLBLÄTTER
FAC SIMIL FICHA DE PEDIDO

MV AGUSTA Motor S.p.A.

Data Date - Datum - Fecha	Mittente Sender - Expéditeur	Cod. concessionario Dealer code - Code du concessionnaire
Stock Stock - Lagerbestand - Stock	Urgente Urgent - Urgent - Dringend - Urgente	Modalità di spedizione Shipping information - Mode d'expédition Versandbestimmungen - Modalidad de envío
Modello Model - Modèle - Modelo	Telaio Frame - Châssis - Rahmen - Bastidor	Motore Engine - Moteur - Motor - Motor
Codice Code - Code - Código	Qnt.	Codice Code - Code - Código
Qnt.	Modello Model - Modèle - Modelo	Telaio Frame - Châssis - Rahmen - Bastidor
Qnt.	Motore Engine - Moteur - Motor - Motor	Codice Code - Code - Código
Qnt.	Qnt.	Qnt.

N.	Code	Qty	Note	BRUTALE ORO	BRUTALE S	▶ I FRAME I ▶	▶ I ENGINE I ▶
1	800092664	1		.	.		
2	8D0066531	1		.	.		

ASSEMBLE SERBATOIO BENZINA
FUEL TANK ASSEMBLY - ENSEMBLE RESERVOIR DE CARBURANT
BAUGRUPPE TANK - CONJUNTO DEPÓSITO GASOLINA

N.	Code	QTY	UNIT	DETALE ORO	DETALE S	▶ I FRAME I ▶	▶ I ENGINE I ▶
1	800092664	1		.	.		
2	800092664	1		.	.		
3	800092664	1		.	.		
4	800092664	1		.	.		
5	800092664	1		.	.		
6	800092664	1		.	.		
7	800092664	1		.	.		
8	800092664	1		.	.		
9	800092664	1		.	.		
10	800092664	1		.	.		
11	800092664	1		.	.		
12	800092664	1		.	.		
13	800092664	1		.	.		
14	800092664	1		.	.		
15	800092664	1		.	.		
16	800092664	1		.	.		
17	800092664	1		.	.		
18	800092664	1		.	.		
19	800092664	1		.	.		
20	800092664	1		.	.		
21	800092664	1		.	.		
22	800092664	1		.	.		
23	800092664	1		.	.		
24	800092664	1		.	.		
25	800092664	1		.	.		
26	800092664	1		.	.		
27	800092664	1		.	.		
28	800092664	1		.	.		
29	800092664	1		.	.		
30	800092664	1		.	.		
31	800092664	1		.	.		
32	800092664	1		.	.		
33	800092664	1		.	.		
34	800092664	1		.	.		
35	800092664	1		.	.		
36	800092664	1		.	.		
37	800092664	1		.	.		
38	800092664	1		.	.		
39	800092664	1		.	.		
40	800092664	1		.	.		

Numero di matricola telaio.
Frame serial number.
Numéro de matricule du cadre.
Rahmennummer.
Número de matrícula bastidor.

Numero di matricola motore.
Engine serial number.
Numéro de série moteur.
Motornummer.
Número de matrícula motor.



INDICE DESCRITTIVO

DESCRIPTIVE INDEX • INDEX DESCRIPTIF
BESCHREIBENDES INHALTSVERZEICHNIS • ÍNDICE DESCRIPTIVO

A01
5

ASSIEME TELAIO

FRAME ASSEMBLY • ENSEMBLE CADRE
BAUGRUPPE RAHMEN • CONJUNTO BASTIDOR

A02
1

ASSIEME TELAIO POSTERIORE

REAR FRAME ASSEMBLY • ENSEMBLE CADRE ARRIÈRE
BAUGRUPPE HINTERER RAHMEN • CONJUNTO BASTIDOR TRASERO

B01
4

ASSIEME FORCELLONE

SWINGING ARM ASSEMBLY • ENSEMBLE FOURCHE
BAUGRUPPE GABEL • CONJUNTO HORQUILLA

B02
2

ASSIEME SOSPENSIONE POSTERIORE

REAR SUSPENSION ASSEMBLY • ENSEMBLE SUSPENSION ARRIÈRE
BAUGRUPPE HINTERRADAUFHÄNGUNG • CONJUNTO SUSPENSIÓN TRASERA

B03
3

ASSIEME SOSPENSIONE ANTERIORE

FRONT SUSPENSION ASSEMBLY • ENSEMBLE SUSPENSION AVANT
BAUGRUPPE VORDERRADAUFHÄNGUNG • CONJUNTO SUSPENSIÓN DELANTERA

B04
1

FORCELLA DESTRA

RIGHT-HAND FORK • FOURCHE DROITE
RECHTE GABEL • HORQUILLA DERECHA

B05
1

FORCELLA SINISTRA

LEFT-HAND FORK • FOURCHE GAUCHE
LINKE GABEL • HORQUILLA IZQUIERDA

C01
2

ASSIEME RUOTA POSTERIORE

REAR WHEEL ASSEMBLY • ENSEMBLE ROUE ARRIÈRE
BAUGRUPPE HINTERRAD • CONJUNTO RUEDA TRASERA

C02
2

ASSIEME RUOTA ANTERIORE

FRONT WHEEL ASSEMBLY • ENSEMBLE ROUE AVANT
BAUGRUPPE VORDERRAD • CONJUNTO RUEDA DELANTERA

D01
2

ASSIEME PEDANA SINISTRA

LEFT-HAND FOOTREST ASSEMBLY • ENSEMBLE REPOSE-PIEDS GAUCHE
BAUGRUPPE LINKES FUSSBRETT • CONJUNTO ESTRIBO IZQUIERDO

D02
2

ASSIEME PEDANA DESTRA

RIGHT-HAND FOOTREST ASSEMBLY • ENSEMBLE REPOSE-PIEDS DROIT
BAUGRUPPE RECHTES FUSSBRETT • CONJUNTO ESTRIBO DERECHO

D03
3

ASSIEME MANUBRIO (LATO DESTRO)

HANDLEBAR ASSEMBLY (RIGHT SIDE) • ENSEMBLE GUIDON (CÔTÉ DROIT)
BAUGRUPPE LENKER (RECHTE SEITE) • CONJUNTO MANILLAR (LADO DERECHO)

D04
2

ASSIEME MANUBRIO (LATO SINISTRO)

HANDLEBAR ASSEMBLY (LEFT SIDE) • ENSEMBLE GUIDON (CÔTÉ GAUCHE)
BAUGRUPPE LENKER (LINKE SEITE) • CONJUNTO MANILLAR (LADO IZQUIERDO)

**D05**
0**SERRATURE**LOCKS • VERROUILLAGES
SCHLÖSSER • CERRADURAS**E01**
4**ASSIEME CARENATURE**FAIRING ASSEMBLY • ENSEMBLE CARÉNAGE
BAUGRUPPE KAROSSERIE UND VERKLEIDUNG • CONJUNTO CARENADOS**E02**
4**ASSIEME CARENATURE**FAIRING ASSEMBLY • ENSEMBLE CARÉNAGE
BAUGRUPPE KAROSSERIE UND VERKLEIDUNG • CONJUNTO CARENADOS**E03**
0**ASSIEME AIRBOX**AIRBOX ASSEMBLY • ENSEMBLE AIRBOX
BAUGRUPPE AIRBOX • CONJUNTO AIRBOX**E04**
5**ASSIEME SERBATOIO BENZINA**FUEL TANK ASSEMBLY • ENSEMBLE RÉSERVOIR DE CARBURANT
BAUGRUPPE TANK • CONJUNTO DEPÓSITO GASOLINA**E05**
5**ASSIEME CODONE**REAR FAIRING ASSEMBLY • ENSEMBLE CARÉNAGE DE SELLE
BAUGRUPPE HECK • CONJUNTO COLÍN**F01**
1**IMPIANTO ELETTRICO**ELECTRIC SYSTEM • INSTALLATION ÉLECTRIQUE
ELEKTRISCHE ANLAGE • INSTALACIÓN ELÉCTRICA**F02**
0**PROIETTORE ANTERIORE**FRONT HEADLIGHT • PROJECTEUR AVANT
SCHEINWERFER • PROYECTOR DELANTERO**F03**
1**IMPIANTO ELETTRICO**ELECTRIC SYSTEM • INSTALLATION ÉLECTRIQUE
ELEKTRISCHE ANLAGE • INSTALACIÓN ELÉCTRICA**F04**
0**IMPIANTO ELETTRICO**ELECTRIC SYSTEM • INSTALLATION ÉLECTRIQUE
ELEKTRISCHE ANLAGE • INSTALACIÓN ELÉCTRICA**F05**
3**IMPIANTO ELETTRICO**ELECTRIC SYSTEM • INSTALLATION ÉLECTRIQUE
ELEKTRISCHE ANLAGE • INSTALACIÓN ELÉCTRICA**F06**
1**IMPIANTO ELETTRICO**ELECTRIC SYSTEM • INSTALLATION ÉLECTRIQUE
ELEKTRISCHE ANLAGE • INSTALACIÓN ELÉCTRICA**F07**
5**IMPIANTO ELETTRICO**ELECTRIC SYSTEM • INSTALLATION ÉLECTRIQUE
ELEKTRISCHE ANLAGE • INSTALACIÓN ELÉCTRICA



INDICE DESCRITTIVO

DESCRIPTIVE INDEX • INDEX DESCRIPTIF
BESCHREIBENDES INHALTSVERZEICHNIS • ÍNDICE DESCRIPTIVO

G01
5

ASSIEME CARTER MOTORE

CRANKCASE ASSEMBLY • ENSEMBLE CARTER DU MOTEUR
BAUGRUPPE MOTORGEHÄUSE • CONJUNTO CÁRTER MOTOR

G02
3

ASSIEME ALBERO MOTORE

CRANK SHAFT ASSEMBLY • ENSEMBLE VILEBREQUIN
BAUGRUPPE KURBELWELLE • CONJUNTO CIGÜEÑAL

G03
2

ASSIEME CILINDRI E PISTONE

CYLINDER AND PISTON ASSEMBLY • ENSEMBLE CYLINDRES ET PISTON
BAUGRUPPE ZYLINDER UND KOLBEN • CONJUNTO CILINDROS Y PISTONES

G04
1

ASSIEME TESTATA

CYLINDER HEAD ASSEMBLY • ENSEMBLE CULASSE
BAUGRUPPE ZYLINDERKOPF • CONJUNTO CULATA

G05
3

DISTRIBUZIONE

TIMING SYSTEM • DISTRIBUTION
VENTILSTEUERUNG • DISTRIBUCIÓN

G06
2

LUBRIFICAZIONE

LUBRICATION SYSTEM • GRAISSAGE
SCHMIERSYSTEM • LUBRIFICACIÓN

G07
0

POMPA ACQUA

WATER PUMP • POMPE À EAU
WASSERPUMPE • BOMBA AGUA

G08
5

IMPIANTO DI RAFFREDDAMENTO

COOLING SYSTEM • CIRCUIT DE REFROIDISSEMENT
KÜHLSYSTEM • INSTALACIÓN DE REFRIGERACIÓN

G09
2

ASSIEME FRIZIONE

CLUTCH ASSEMBLY • ENSEMBLE EMBRAYAGE
BAUGRUPPE KUPPLUNG • CONJUNTO EMBRAGUE

G10
3

ASSIEME CAMBIO

CHANGE GEAR ASSEMBLY • ENSEMBLE BOÎTE DE VITESSE
BAUGRUPPE GETRIEBE • CONJUNTO CAMBIO

G11
4

SELETTORE CAMBIO

GEAR SELECTOR • SÉLECTEUR DE VITESSES
GANGSCHALTER • SELECTOR CAMBIO

G12
1

GRUPPO POMPA BENZINA

FUEL PUMP ASSEMBLY • GROUPE POMPE D'ALIMENTATION
BAUGRUPPE BENZINPUMPE • GRUPO BOMBA GASOLINA

G13
4

ALIMENTAZIONE MOTORE

FUEL SYSTEM • ALIMENTATION MOTEUR
MOTORVERSORGUNG • ALIMENTACIÓN MOTOR

INDICE DESCRITTIVO

DESCRIPTIVE INDEX • INDEX DESCRIPTIF
BESCHREIBENDES INHALTSVERZEICHNIS • ÍNDICE DESCRIPTIVO



G14
3

AVVIAMENTO

STARTING SYSTEM • DÉMARREUR
ANLASSERSYSTEM • PUESTA EN MARCHA

G15
0

IMPIANTO ELETTRICO MOTORE

ENGINE ELECTRIC SYSTEM • INSTALLATION ÉLECTRIQUE MOTEUR
ELEKTRISCHE ANLAGE MOTOR • INSTALACIÓN ELÉCTRICA MOTOR

G16
2

IMPIANTO DI SCARICO

EXHAUST SYSTEM • ÉCHAPPEMENT
ABGASANLAGE • INSTALACIÓN DE ESCAPE

H01
3

DOTAZIONI

OUTFIT • ÉQUIPEMENT
BORDWERKZEUG • EQUIPAMIENTO

J01
0

ATTREZZATURE DI SERVIZIO (CICLISTICA)

SERVICE TOOLS (FRAME) • MATÉRIEL (PARTIE CYCLE)
SPEZIALWERKZEUG (RAHMEN) • UTILLAJE DE SERVICIO (MOTOCICLETA)

J02
0

ATTREZZATURE DI SERVIZIO (CICLISTICA)

SERVICE TOOLS (FRAME) • MATÉRIEL (PARTIE CYCLE)
SPEZIALWERKZEUG (RAHMEN) • UTILLAJE DE SERVICIO (MOTOCICLETA)

J03
3

ATTREZZATURE DI SERVIZIO (MOTORE)

SERVICE TOOLS (ENGINE) • MATÉRIEL (MOTEUR)
SPEZIALWERKZEUG (MOTOR) • UTILLAJE DE SERVICIO (MOTOR)

J04
4

ATTREZZATURE DI SERVIZIO (MOTORE)

SERVICE TOOLS (ENGINE) • MATÉRIEL (MOTEUR)
SPEZIALWERKZEUG (MOTOR) • UTILLAJE DE SERVICIO (MOTOR)

K01
0

VARIANTI ESTERO

VERSIONS FOR FOREIGN COUNTRIES • VARIANTES ÉTRANGER
MODELLVARIANTEN AUSLAND • VARIANTES EXTRANJERO

K02
1

ASSIEME CANISTER (USA)

CARBON CANISTER ASSEMBLY (USA) • ENSEMBLE CANISTER (USA)
BAUGRUPPE CARBONKANISTER (USA) • CONJUNTO CANISTER (USA)

Z01
11

INDICE CODICI / DENOMINAZIONI

CODEx / DESIGNATION INDEX • INDEX CODES / DÉNOMINATIONS
INHALTSVERZEICHNIS CODE • ÍNDICE CÓDIGOS / DENOMINACIONES



INDICE FIGURATIVO

FIGURATIVE INDEX • INDEX FIGURATIF
 BILDVERZEICHNIS • ÍNDICE DE FIGURAS

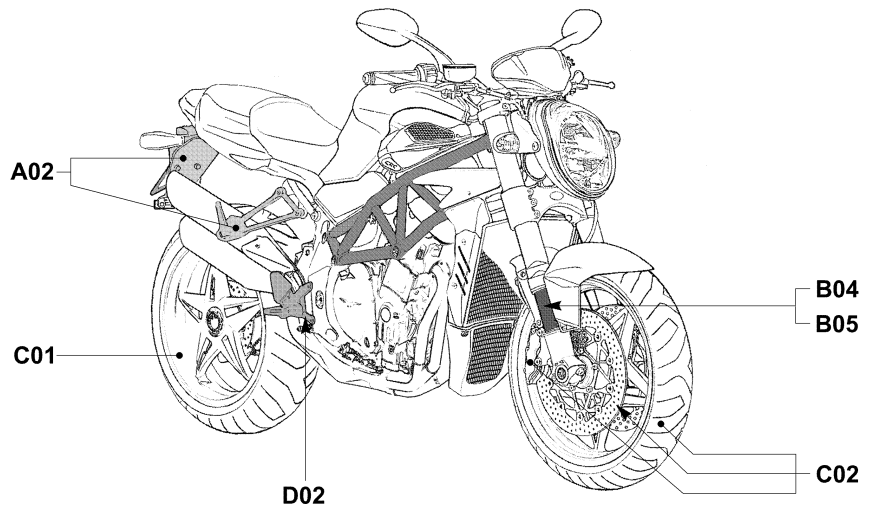
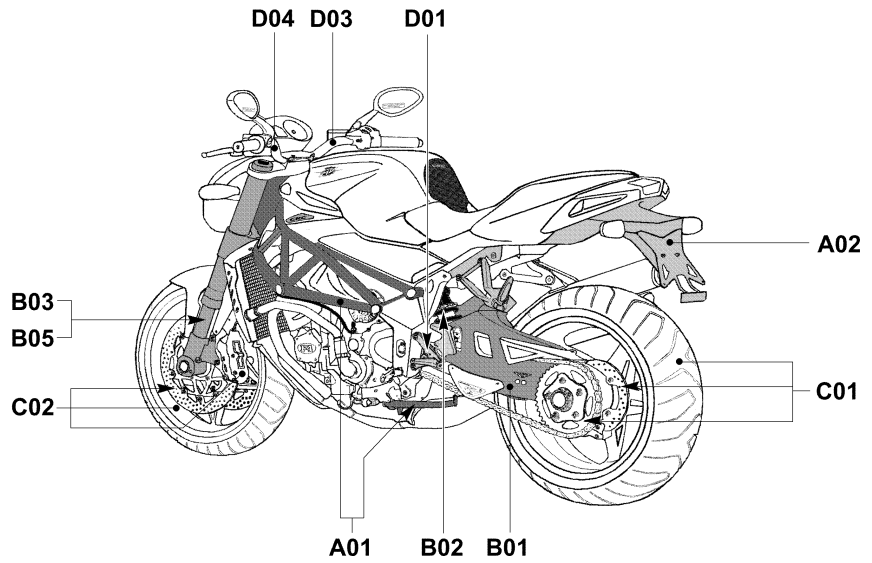
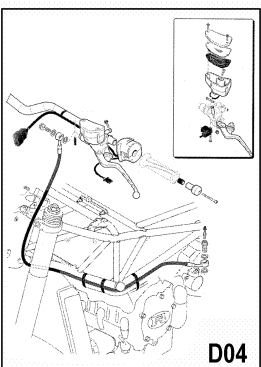
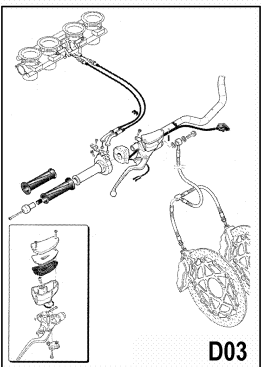
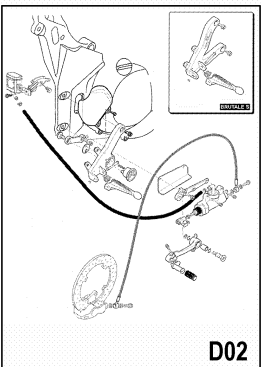
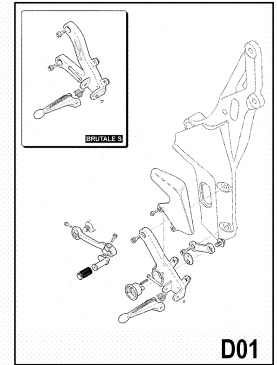
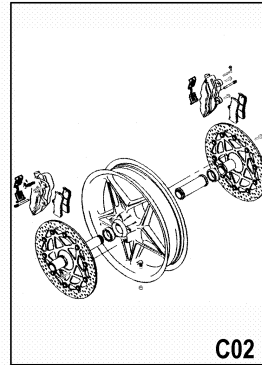
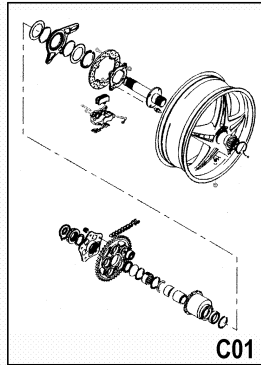
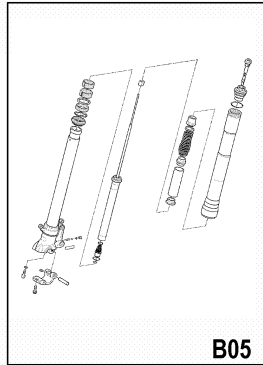
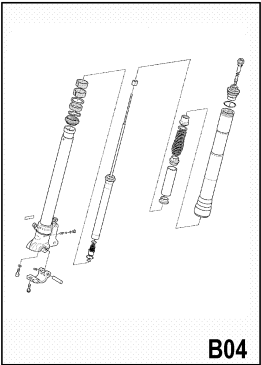
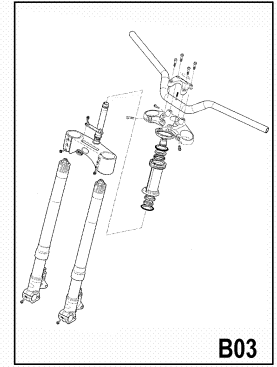
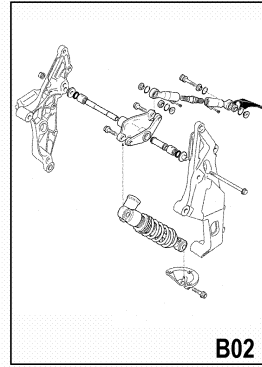
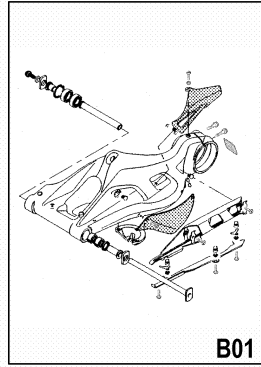
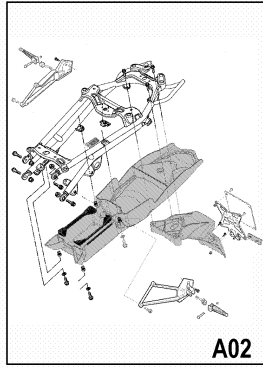
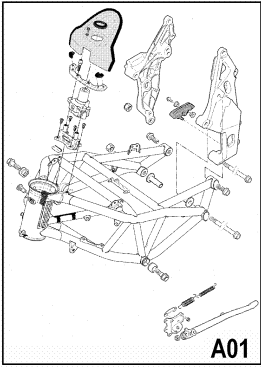

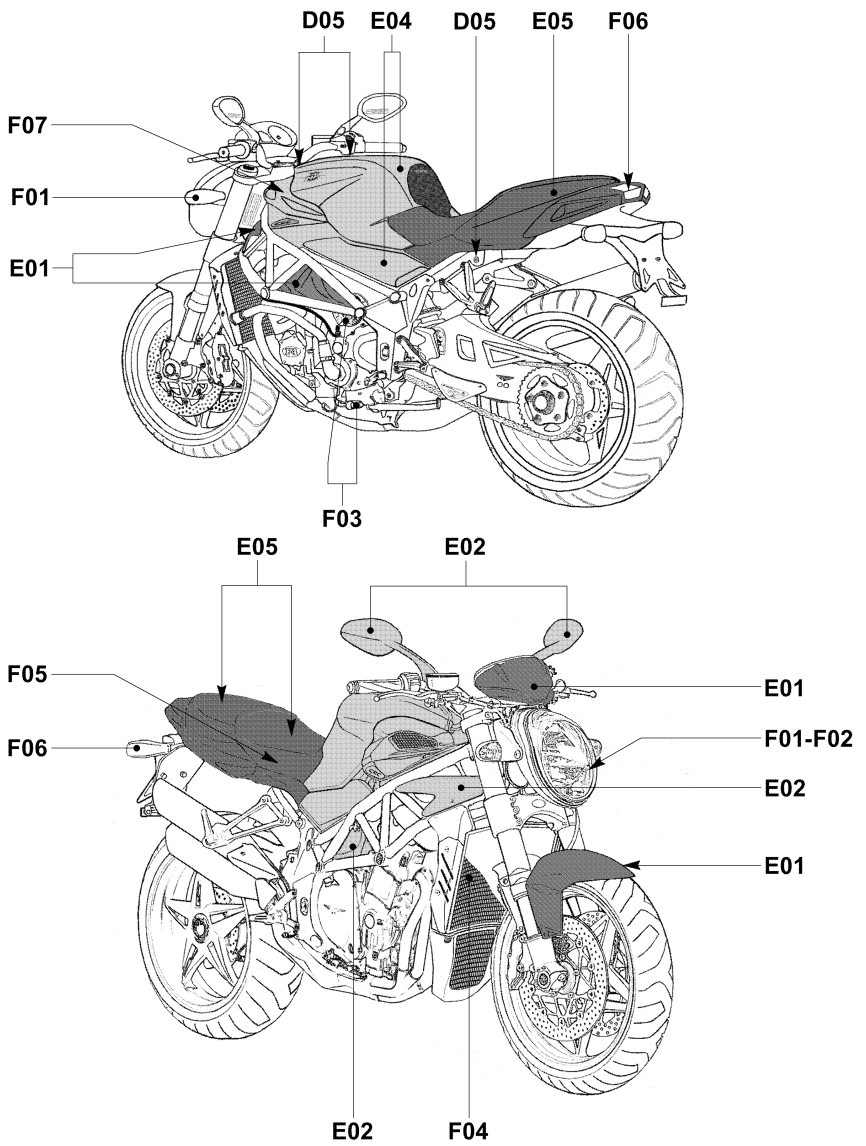
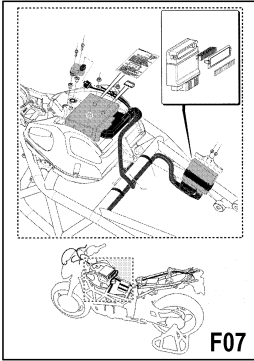
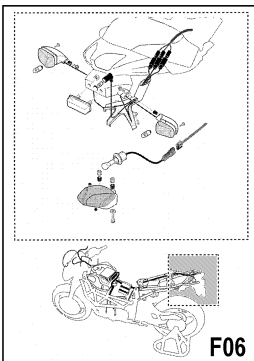
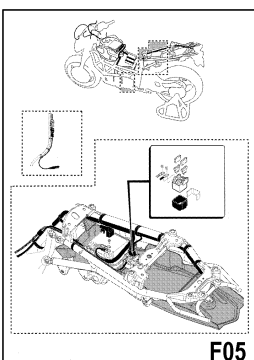
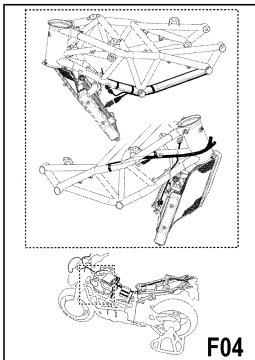
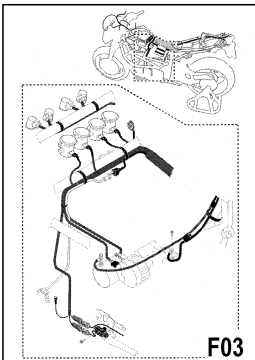
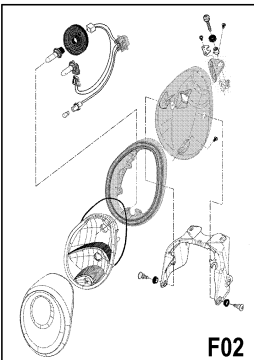
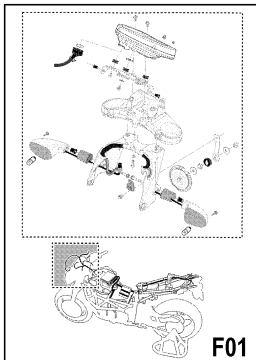
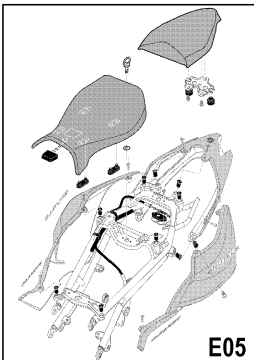
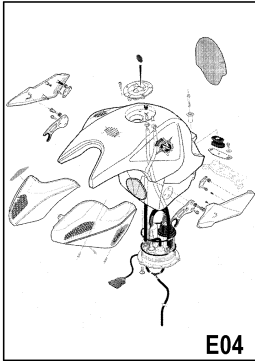
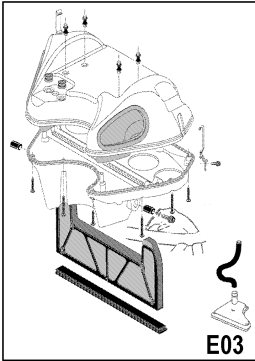
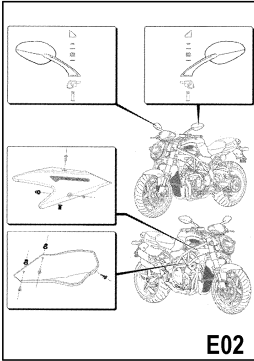
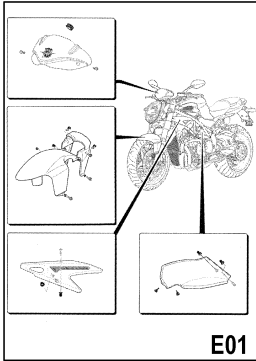
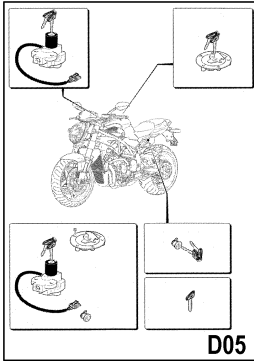



INDICE FIGURATIVO

FIGURATIVE INDEX • INDEX FIGURATIF
BILDVERZEICHNIS • ÍNDICE DE FIGURAS

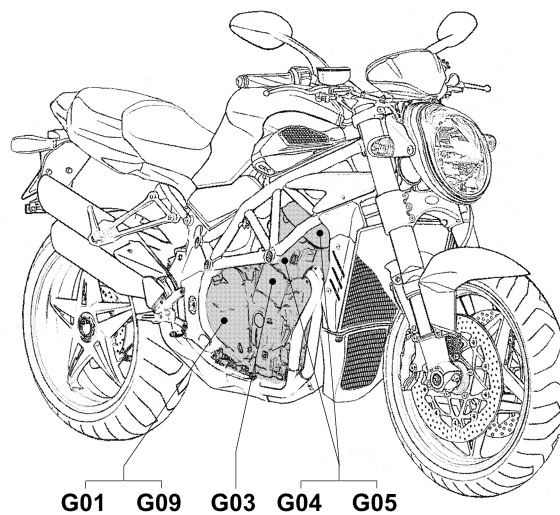
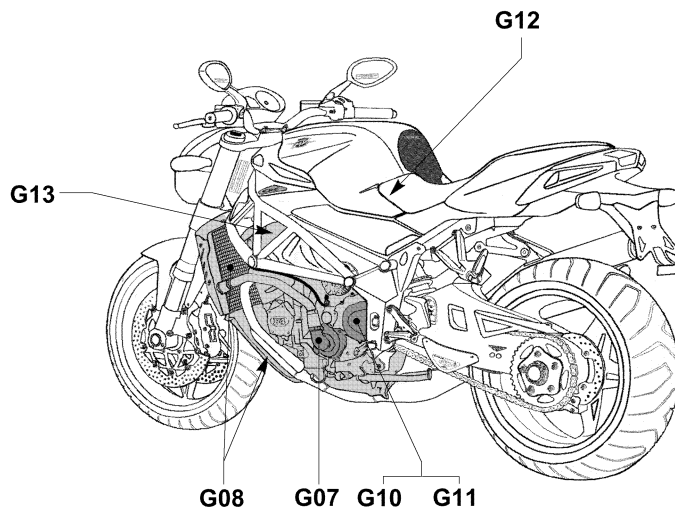
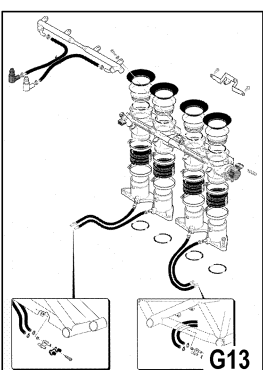
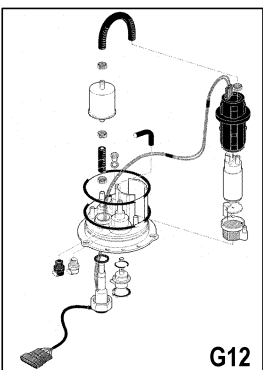
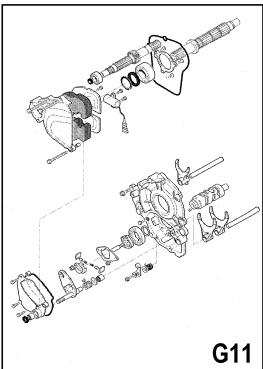
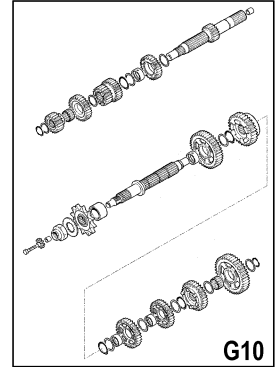
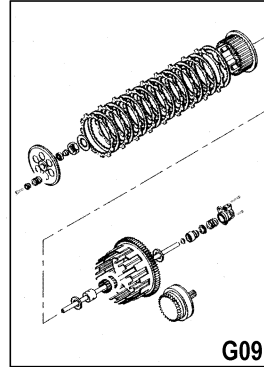
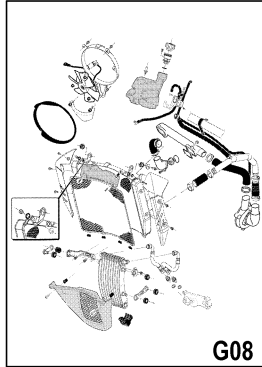
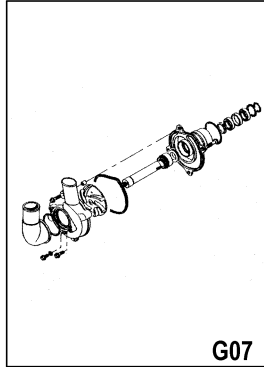
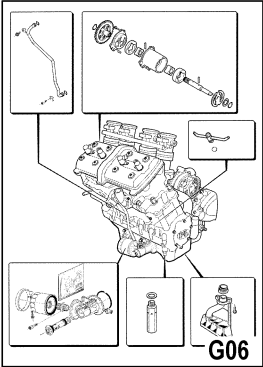
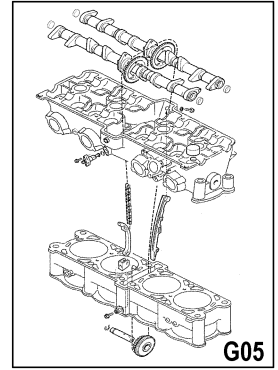
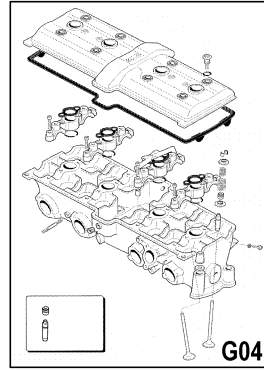
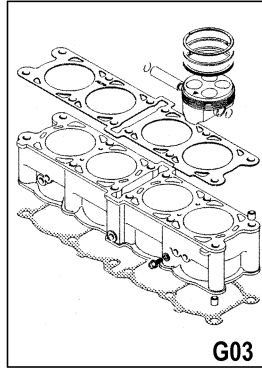
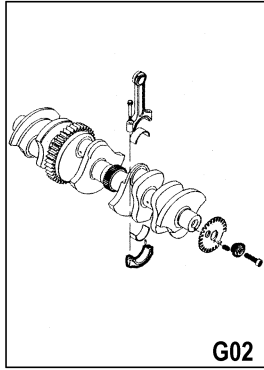
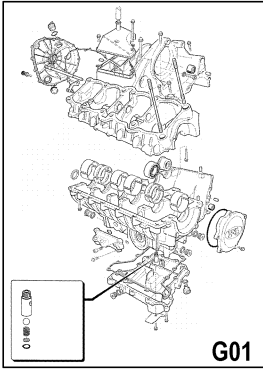

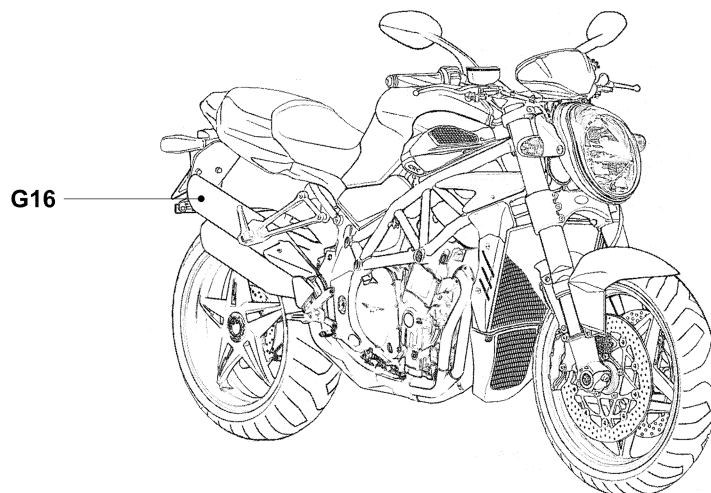
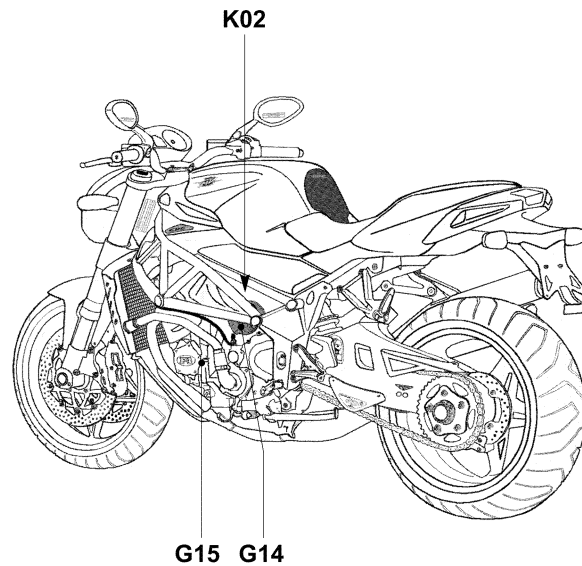
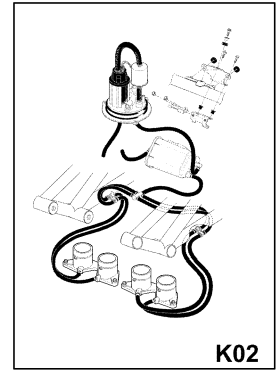
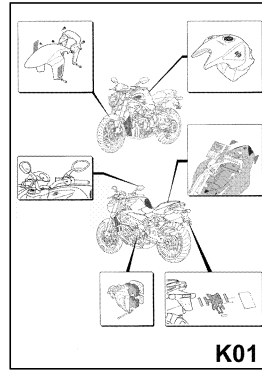
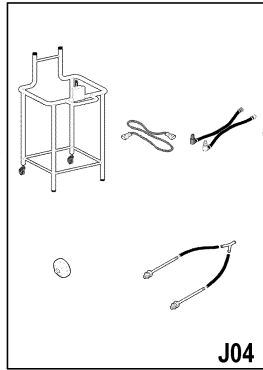
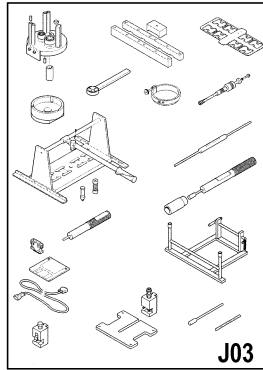
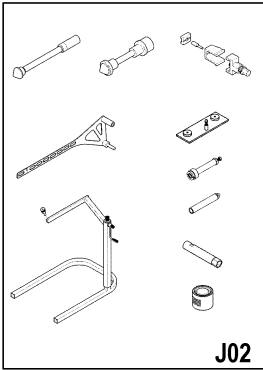
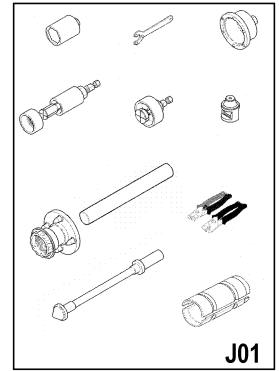
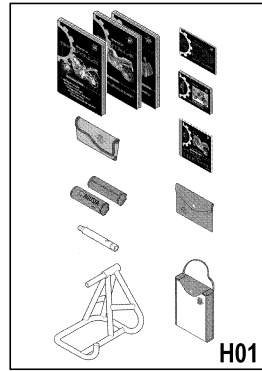
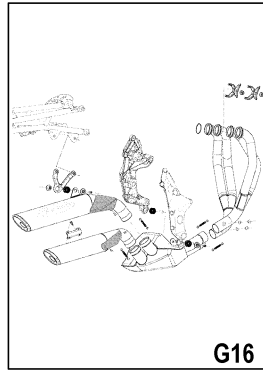
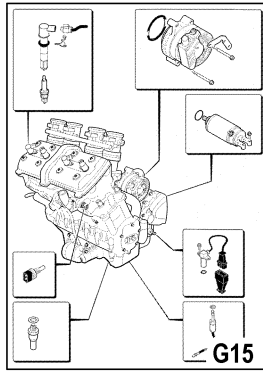
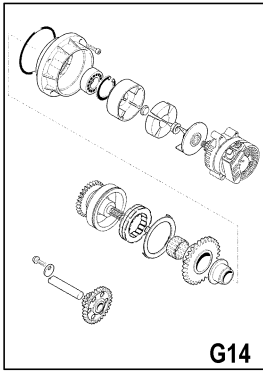



ASSIEME TELAIO
FRAME ASSEMBLY • ENSEMBLE CADRE
BAUGRUPPE RAHMEN • CONJUNTO BASTIDOR

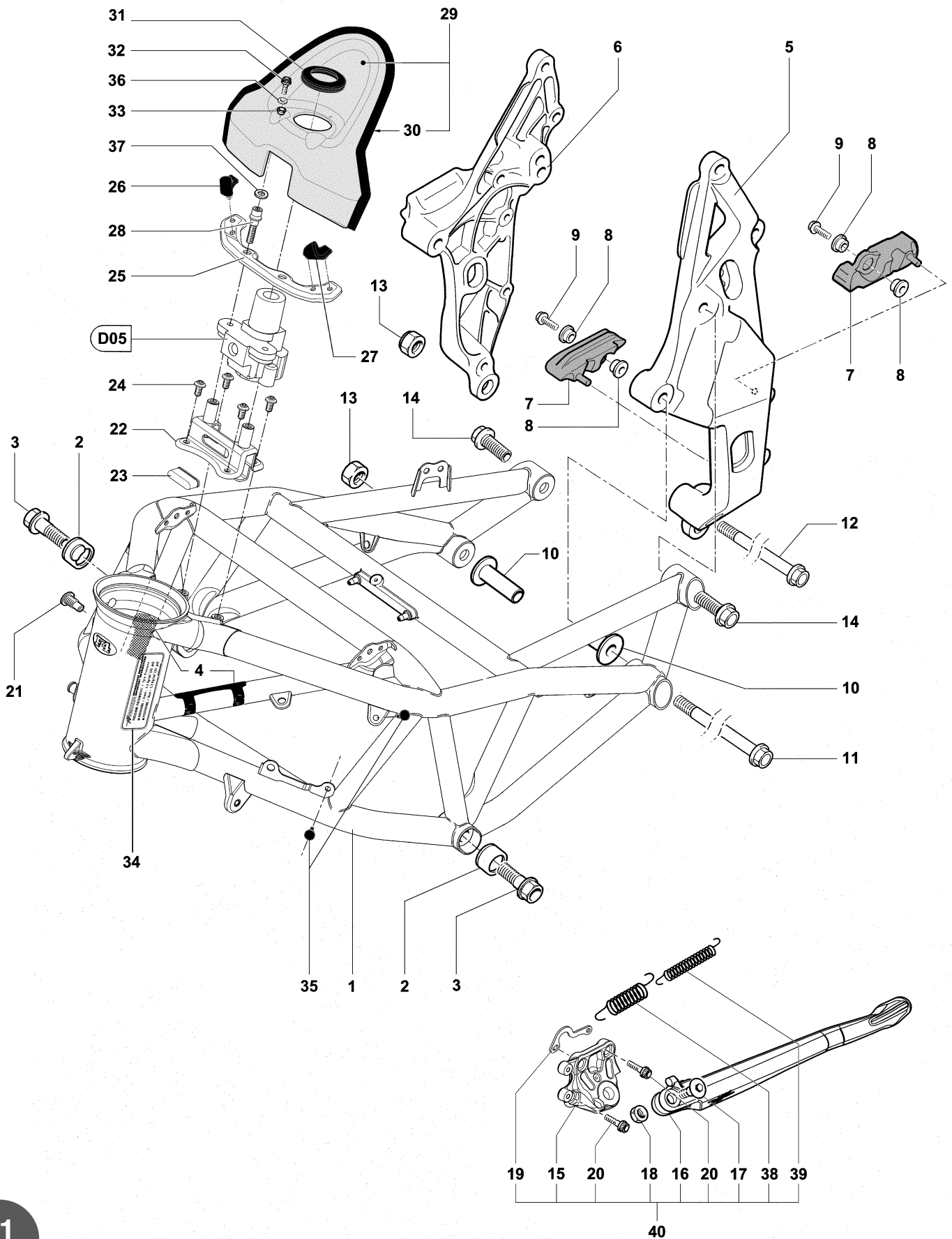

ASSIEME TELAIO

 FRAME ASSEMBLY • ENSEMBLE CADRE
 BAUGRUPPE RAHMEN • CONJUNTO BASTIDOR

N.	Code	Q.ty	Note	BRUTALE ORO	BRUTALE S	► I FRAME I ►	► I ENGINE I ►
1	80A097904	1		.			
1	80A097904	1	A B		.		
1	80B097904	1	C D		.		
2	800084871	2		.	.		
3	800084869	2		.	.		
4	800090417	2		.	.		
5	800099132	1		.			
5	800097899	1			.		
6	800090236	1		.			
6	800097900	1			.		
7	800087476	2		.	.		
8	800090392	4		.	.		
9	800062728	2		.	.		
10	8A0084857	2		.	.		
11	800084866	1		.	.		
12	800084865	1		.	.		
13	800042023	2		.	.		
14	800084867	2		.	.		
15	8000B4782	1	1	.	.		
16	80A0B3583	1	1	.	.		
17	80A090431	1	1	.	.		
18	80A090432	1	1	.	.		
19	8000B3584	1	1	.	.		
20	8F0090426	3		.	.		
21	800084915	1		.	.		
22	800098717	1		.	.		
23	800099426	1		.	.		
24	8A0089786	4		.	.		
25	800099327	1		.	.		
26	800099398	1		.	.		
27	800099397	1		.	.		
28	800099142	2		.	.		
29	800099283	1		.			
29	800099428	1			.		
30	8A0091693	1		.	.		
31	800098826	1		.	.		
32	8D0090424	2		.	.		
33	800092658	2			.		
34	8000A1487	1	3	.			
34	8000A1487	1	3		.		► I 10760
34	8000A4000	1	3		.		10761 I ►
35	800099419	4		.	.		
36	8000A3474	2		.			
37	800056359	2			.		
38	8000B3987	1	1	.	.		
39	8000B3986	1	1	.	.		
40	80A0B4781	1	2	.	.		

A Versione Rossa - Red version - Version Rouge - Rote Version - Versión Roja.

B Versione Nera - Black version - Version Noire - Schwarze Version - Versión Negra.

C Versione Argento - Silver version - Version Argent - Silber Version - Versión Plata.

D Versione Rosso/Nera - Red/Black version - Version Rouge/Noire - Rot/Schwarze Version - Versión Rojo/Negra.

1 Dopo la sostituzione del part. N° 40 - After replacement of part No. 40 - Suite à le remplacement du pièce N° 40 - Nach Wechsel von Teil Nr. 40 - Después de la sustitución de la pieza N° 40.

2 Kit cavalletto laterale - Side stand kit - Kit béquille latérale - Bausatz seitlicher Ständer - Kit caballete lateral.

3 Esclusi gli USA - USA excluded - Sauf les USA - Ausschließlich USA - Excluidos los USA.

A01

5



ASSIEME TELAIO POSTERIORE

REAR FRAME ASSEMBLY • ENSEMBLE CADRE ARRIÈRE

BAUGRUPPE HINTERER RAHMEN • CONJUNTO BASTIDOR TRASERO

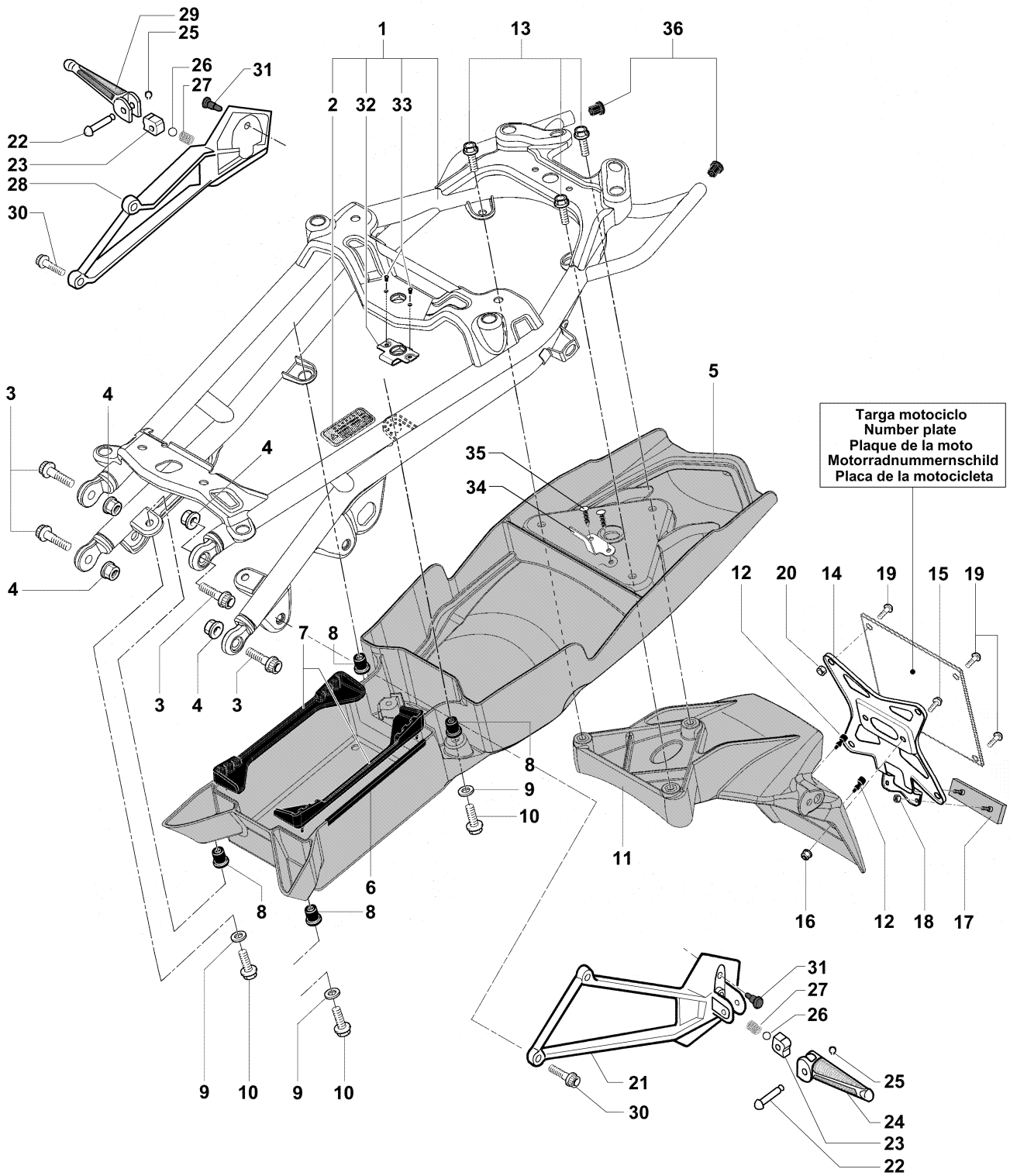

Targa motociclo
Number plate
Plaque de la moto
Motorradnummernschild
Placa de la motocicleta

ASSIEME TELAIO POSTERIORE

REAR FRAME ASSEMBLY • ENSEMBLE CADRE ARRIÈRE

BAUGRUPPE HINTERER RAHMEN • CONJUNTO BASTIDOR TRASERO



N.	Code	Q.ty	Note	BRUTALE ORO	BRUTALE S	► I FRAME I ►	► I ENGINE I ►
1	800099263	1		•	•		
2	800092257	1		•	•		
3	8J0090426	4		•	•		
4	80B043928	4		•	•		
5	8000A1038	1		•	•		
6	8B0047859	1		•	•		
7	800066339	4	①	•			
7	8000A3226	2	②	•			
7	800066339	4	①		•		► I 10760
7	8000A3226	2	②		•		► I 10760
7	8000A3226	2			•		10761 I ►
8	800048245	4		•	•		
9	800089751	4		•	•		
10	800089786	4		•	•		
11	800099120	1		•	•		
12	800095828	2		•	•		
13	800062726	3		•	•		
14	800094506	1	③	•	•		
15	8H0067545	2	③	•	•		
16	800044240	2		•	•		
17	800090374	1		•	•		
18	800091033	2		•	•		
19	80A047053	4		•	•		
20	800091033	4		•	•		
21	80A094169	1		•	•		
22	80A053546	2		•	•		
23	800094171	2		•	•		
24	80A091661	1		•	•		
25	800090429	2		•	•		
26	6BN021507	2		•	•		
27	800094170	2		•	•		
28	80A098721	1		•	•		
29	80A091662	1		•	•		
30	8G0090426	4		•	•		
31	800095828	2		•	•		
32	800069150	1		•	•		
33	800094279	2		•	•		
34	8000A1079	1		•	•		
35	80A063228	2		•	•		
36	8000A2733	2		•	•		

① Prima della sostituzione del Part. N° 9 - Tavola F05 • Before replacement of Part No. 9 - Table F05 • Avant de le remplacement du pièce N° 9 - Planche F05 • Bevor Wechsel von Teil Nr. 9 - Tafel F05 • Antes de la sustitución de la pieza N° 9 - Tabla F05.

② Dopo la sostituzione del part. N° 9 - Tavola F05 • After replacement of part No. 9 - Table F05 • Suite à le remplacement du pièce N° 9 - Planche F05 • Nach Wechsel von Teil Nr. 9 - Tafel F05 • Después de la sustitución de la pieza N° 9 - Tabla F05.

③ Esclusa l'Australia (vedi tavola K01) - Australia excluded (see table K01) - Sauf l'Australie (voir planche K01) - Ausschließlich Australie (siehe Tafel K01) - Excluida la Australia (ver tabla K01).



ASSIEME FORCELLONE
SWINGING ARM ASSEMBLY • ENSEMBLE FOURCHE
BAUGRUPPE GABEL • CONJUNTO HORQUILLA

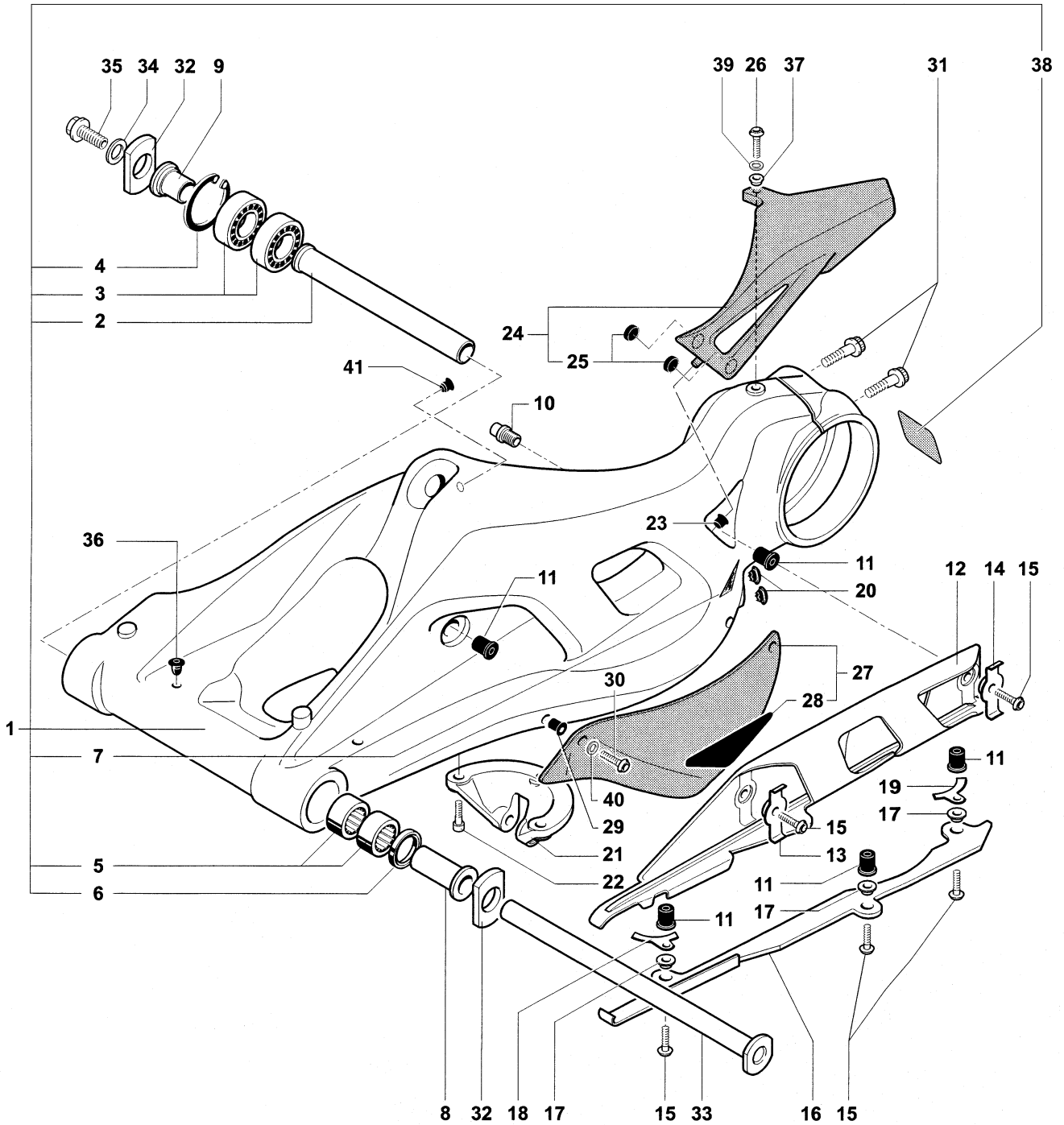

ASSIEME FORCELLONE

 SWINGING ARM ASSEMBLY • ENSEMBLE FOURCHE
 BAUGRUPPE GABEL • CONJUNTO HORQUILLA

N.	Code	Q.ty	Note	BRUTALE ORO	BRUTALE S	► I FRAME I ►	► I ENGINE I ►
1	800093316	1		.			
1	800093854	1			.		
2	800084872	1		.	.		
3	800084938	2		.	.		
4	800084939	1		.	.		
5	800084936	2		.	.		
6	800084937	1		.	.		
7	800091641	1		.			
8	800084859	1		.	.		
9	800084873	1		.	.		
10	800090399	1		.	.		
11	800048245	5		.	.		
12	800092652	1		.			
12	800087473	1			.		
13	800087463	1		.	.		
14	800089300	1		.	.		
15	800089786	5		.	.		
16	800087475	1		.	.		
17	800090391	3		.	.		
18	800090998	1		.	.		
19	800090999	1		.	.		
20	8B0070695	2		.			
21	800087441	1		.	.		
22	8L0082751	3		.	.		
23	800092631	1		.	.		
24	80A092671	1		.			
24	80A0A6107	1	❶	.			
24	800092849	1			.		
24	8000A6106	1	❶		.		
25	800090979	2		.	.		
26	8A0089786	1		.	.		
27	80A093317	1		.			
27	800093855	1			.		► I 10760
27	8000A4581	1			.		10761 I ►
28	800092667	1		.			
28	800092667	1			.		► I 10760
28	8000A4580	1			.		10761 I ►
29	800091022	2		.	.		
30	8A0090901	2		.	.		
31	800078221	2		.	.		
32	800086446	2		.			
33	800084864	1		.			
33	800091655	1			.		
34	800086396	1		.	.		
35	800086395	1		.	.		
36	800094895	1			.		
37	800092670	1			.		
38	8000A2734	1		.	.		
39	800089751	1		.			
40	800092882	2		.			
41	8000A4539	3		.	.		

❶ Versione allungata - Elongated version - Version rallongée - Längliche Version - Versión alargada.



ASSIEME SOSPENSIONE POSTERIORE

REAR SUSPENSION ASSEMBLY • ENSEMBLE SUSPENSION ARRIÈRE

BAUGRUPPE HINTERRADAUFHÄNGUNG • CONJUNTO SUSPENSIÓN TRASERA

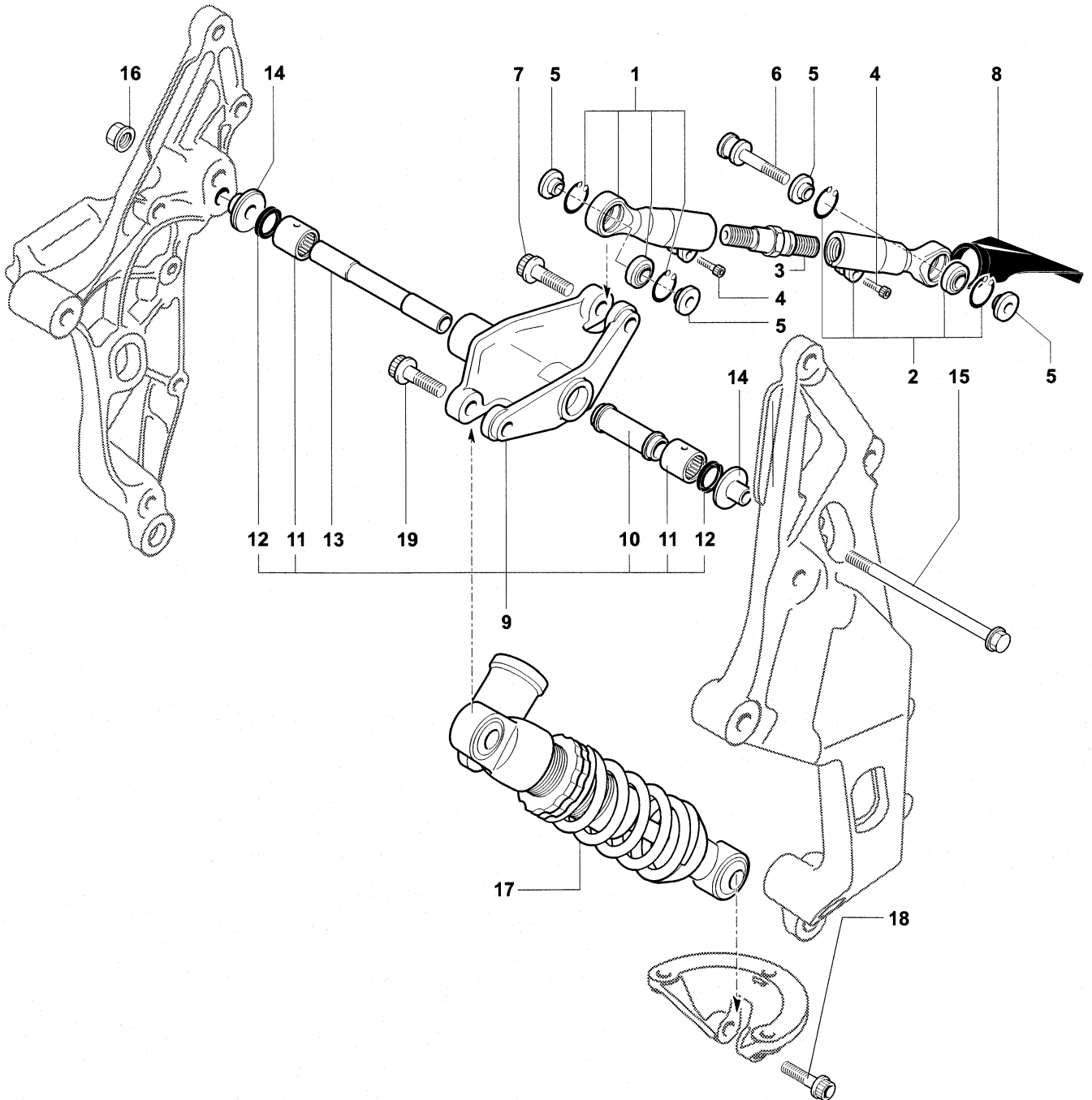

ASSIEME SOSPENSIONE POSTERIORE

REAR SUSPENSION ASSEMBLY • ENSEMBLE SUSPENSION ARRIÈRE

BAUGRUPPE HINTERRADAUFHÄNGUNG • CONJUNTO SUSPENSIÓN TRASERA



N.	Code	Q.ty	Note	BRUTALE ORO	BRUTALE S	► I FRAME I ►	► I ENGINE I ►
1	800093318	1		•	•		
2	800093319	1		•	•		
3	800084875	1		•			
3	800084875	1			•		► I 10760
3	8000A4508	1			•		10761 I ►
4	8G0090425	2		•	•		
5	800084874	4		•	•		
6	800084868	1		•	•		
7	8P0082751	1		•	•		
8	800091027	1		•	•		
9	800093320	1		•	•		
10	800089757	1		•	•		
11	800084945	2		•	•		
12	800084946	2		•	•		
13	800084858	1		•	•		
14	800086447	2		•	•		
15	800084863	1		•	•		
16	800042022	1		•	•		
17	8000A3997	1		•	•		
18	8S0082751	1		•	•		
19	8R0082751	1		•	•		



ASSIEME SOSPENSIONE ANTERIORE

FRONT SUSPENSION ASSEMBLY • ENSEMBLE SUSPENSION AVANT

BAUGRUPPE VORDERRADAUFHÄNGUNG • CONJUNTO SUSPENSIÓN DELANTERA

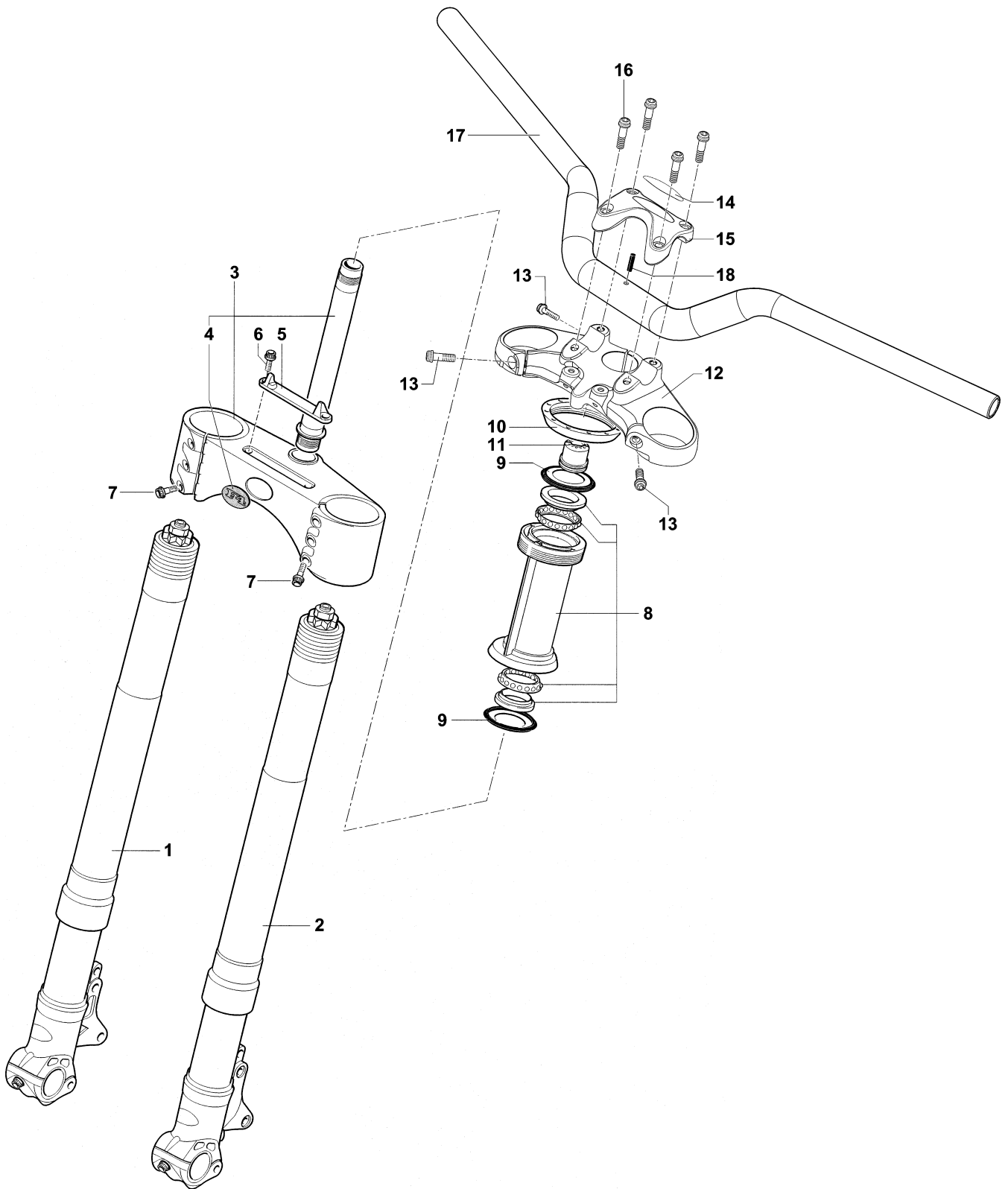

ASSIEME SOSPENSIONE ANTERIORE

FRONT SUSPENSION ASSEMBLY • ENSEMBLE SUSPENSION AVANT

BAUGRUPPE VORDERRADAUFHÄNGUNG • CONJUNTO SUSPENSIÓN DELANTERA



N.	Code	Q.ty	Note	BRUTALE ORO	BRUTALE S	► I FRAME I ►	► I ENGINE I ►
1	80A0A1500	1		•			
1	8000A1500	1			•		► I 10760
1	8000A3178	1			•		10761 I ►
2	80A0A1501	1		•			
2	8000A1501	1			•		► I 10760
2	8000A3179	1			•		10761 I ►
3	800093315	1		•			
3	800093852	1			•		
4	800091683	1		•			
5	8A0086407	1		•	•		
6	8E0090425	2		•	•		
7	8H0090425	6		•	•		
8	8AA090279	1		•	•		
9	800090897	2		•	•		
10	800086436	1		•	•		
11	8A0090280	1		•	•		
12	800098332	1		•	•		
13	8G0090426	3		•	•		
14	800099410	1			•		
15	800098322	1		•	•		
16	8J0090426	4		•	•		
17	800098329	1		•	•		
18	6AN155037	1		•	•		



FORCELLA DESTRA
RIGHT-HAND FORK • FOURCHE DROITE
RECHTE GABEL • HORQUILLA DERECHA

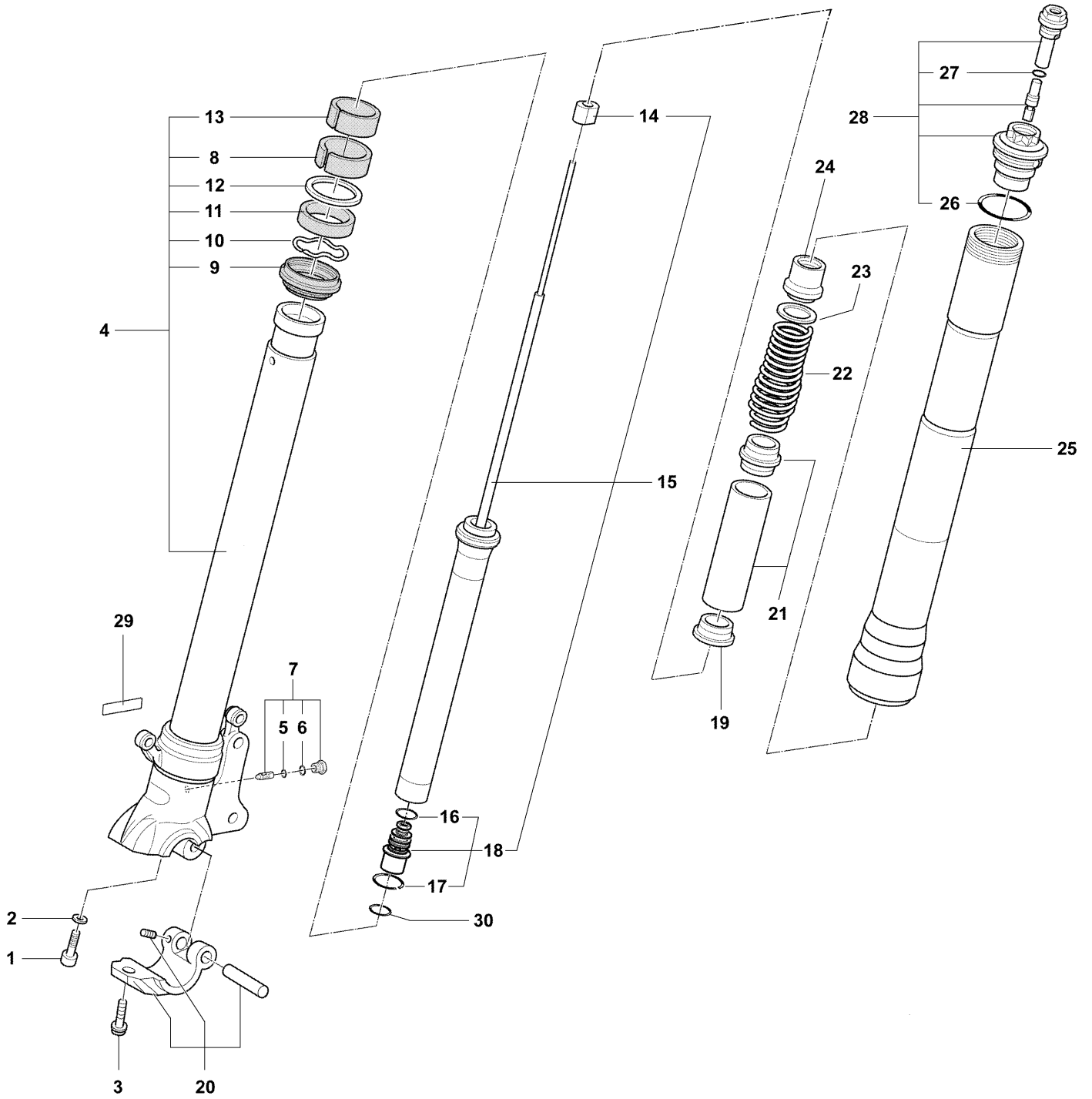

FORCELLA DESTRA
 RIGHT-HAND FORK • FOURCHE DROITE
 RECHTE GABEL • HORQUILLA DERECHA



N.	Code	Q.ty	Note	BRUTALE ORO	BRUTALE S	► I FRAME I ►	► I ENGINE I ►
1	8000A0841	1		•	•		
2	800031113	1		•	•		
3	800082708	1		•	•		
4	80A0A1858	1		•			
4	8000A1858	1			•		
5	8000A0826	1		•	•		
6	800050679	1		•	•		
7	8000A1859	1		•	•		
8	8000A1860	1		•	•		
9	8000A4690	1		•	•		
10	800089274	1		•	•		
11	800086500	1		•	•		
12	800089275	1		•	•		
13	800086503	1		•	•		
14	800081174	1		•	•		
15	8000A1861	1		•			
15	8000A1861	1			•		► I 10760
15	8000A4692	1			•		10761 I►
16	800019789	1		•	•		
17	800081164	1		•	•		
18	8000A1862	1		•			
18	8000A1862	1			•		► I 10760
18	8000A4691	1			•		10761 I►
19	8000A1863	1		•	•		
20	8000A1864	1		•	•		
21	8000A1866	1		•	•		
22	8000A2039	1		•	•		
23	8000A1867	1		•	•		
24	8000A1868	1		•	•		
25	8000A1869	1		•	•		
26	8000A1870	1		•	•		
27	8000A0817	1		•	•		
28	8000A1871	1		•			
28	8000A1871	1			•		► I 10760
28	8000A4693	1			•		10761 I►
29	8000A1872	1		•	•		
30	800029074	1			•		10761 I►



FORCELLA SINISTRA
LEFT-HAND FORK • FOURCHE GAUCHE
LINKE GABEL • HORQUILLA IZQUIERDA

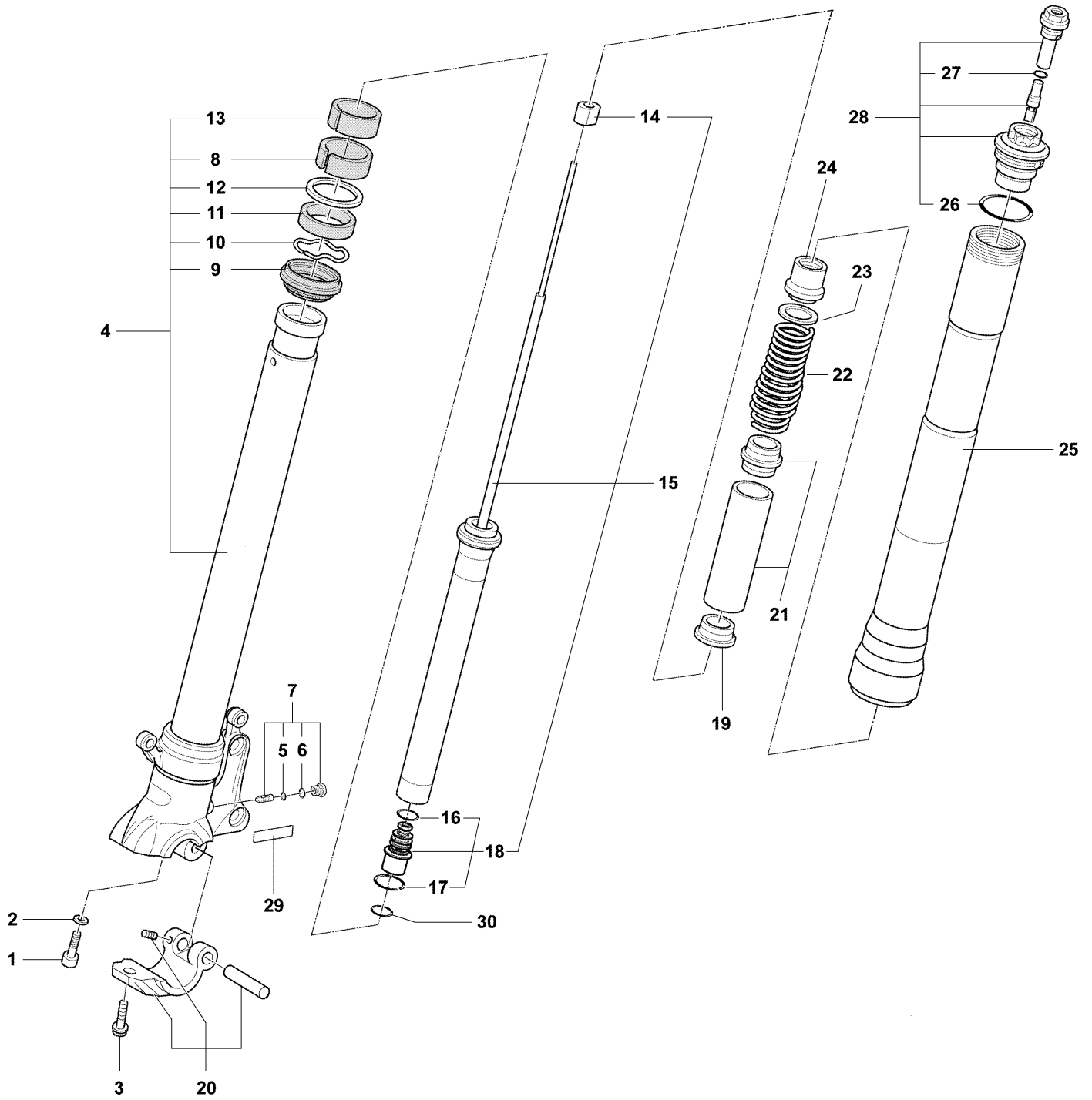

FORCELLA SINISTRA
 LEFT-HAND FORK • FOURCHE GAUCHE
 LINKE GABEL • HORQUILLA IZQUIERDA



N.	Code	Q.ty	Note	BRUTALE ORO	BRUTALE S	► I FRAME I ►	► I ENGINE I ►
1	8000A0841	1		•	•		
2	800031113	1		•	•		
3	800082708	1		•	•		
4	80A0A1857	1		•			
4	8000A1857	1			•		
5	8000A0826	1		•	•		
6	800050679	1		•	•		
7	8000A1859	1		•	•		
8	8000A1860	1		•	•		
9	8000A4690	1		•	•		
10	800089274	1		•	•		
11	800086500	1		•	•		
12	800089275	1		•	•		
13	800086503	1		•	•		
14	800081174	1		•	•		
15	8000A1861	1		•			
15	8000A1861	1			•		► I 10760
15	8000A4692	1			•		10761 I►
16	800019789	1		•	•		
17	800081164	1		•	•		
18	8000A1862	1		•			
18	8000A1862	1			•		► I 10760
18	8000A4691	1			•		10761 I►
19	8000A1863	1		•	•		
20	8000A1865	1		•	•		
21	8000A1866	1		•	•		
22	8000A2039	1		•	•		
23	8000A1867	1		•	•		
24	8000A1868	1		•	•		
25	8000A1869	1		•	•		
26	8000A1870	1		•	•		
27	8000A0817	1		•	•		
28	8000A1871	1		•			
28	8000A1871	1			•		► I 10760
28	8000A4693	1			•		10761 I►
29	8000A1872	1		•	•		
30	800029074	1			•		10761 I►



ASSIEME RUOTA POSTERIORE

REAR WHEEL ASSEMBLY • ENSEMBLE ROUE ARRIÈRE
BAUGRUPPE HINTERRAD • CONJUNTO RUEDA TRASERA

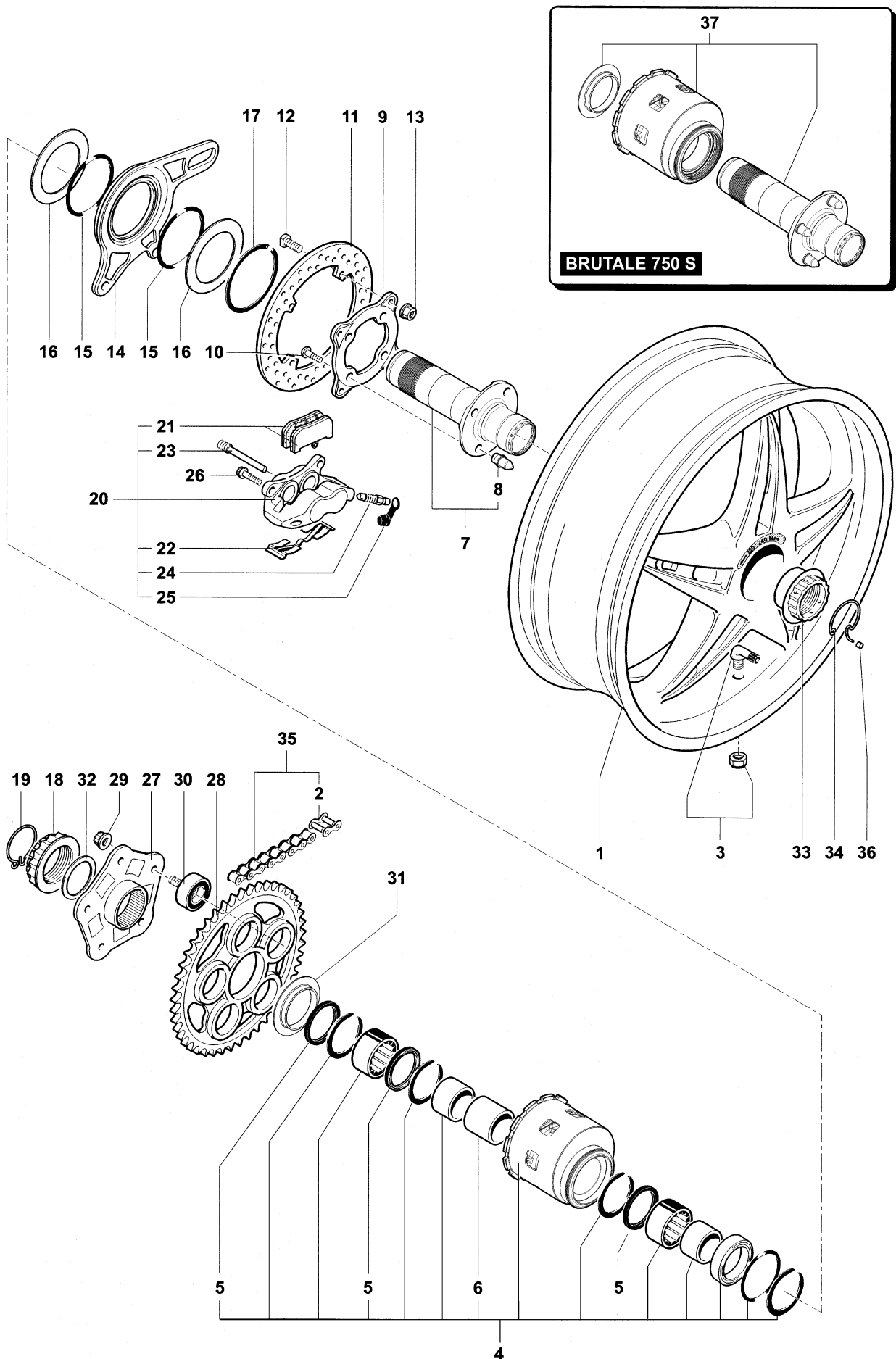

ASSIEME RUOTA POSTERIORE

 REAR WHEEL ASSEMBLY • ENSEMBLE ROUE ARRIÈRE
 BAUGRUPPE HINTERRAD • CONJUNTO RUEDA TRASERA

N.	Code	Q.ty	Note	BRUTALE ORO	BRUTALE S	► I FRAME I ►	► I ENGINE I ►
1	8AA090353	1		•			
1	8AB090983	1			•		
2	800093864	1		•	•		
3	800091011	1		•	•		
4	800091013	1		•			
4	8000B2143	1	❶		•		
5	800084909	2		•			
5	800084909	3	❶		•		
6	800084914	1		•			
6	8000B2149	1	❶		•		
7	800092888	1		•			
7	8000B3392	1	❶		•		
8	800084901	4		•			
8	80A084901	4	❶		•		
9	800084890	1		•	•		
10	800084902	4		•	•		
11	800082760	1		•	•		
12	800084889	4		•	•		
13	800084891	4		•	•		
14	800082761	1		•			
14	800082761	1			•		► I 10760
14	8000A3551	1			•		10761 I ►
15	800086702	2		•	•		
16	800084893	2		•	•		
17	800084913	1		•	•		
18	800084904	1		•	•		
19	800084898	1		•	•		
20	800082753	1		•	•		
21	800082748	1		•	•		
22	800082746	1		•	•		
23	800082743	1		•	•		
24	800089484	1		•	•		
25	800089491	1		•	•		
26	8E0090426	2		•	•		
27	800078219	1		•	•		
28	8B0084926	1		•			
28	800098708	1			•		
29	800084952	5		•	•		
30	800078224	5		•	•		
31	800084896	1		•			
31	8000B4955	1	❶		•		
32	800084894	1		•	•		
33	800084903	1		•	•		
34	800084899	1		•	•		
35	800091682	1		•	•		
36	800094030	1		•	•		
37	8000B4954	1	❷		•		

- ❶ Dopo la sostituzione del part. N° 37 - After replacement of part No. 37 - Suite à le remplacement du pièce N° 37 - Nach Wechsel von Teil Nr. 37 - Después de la sustitución de la pieza N° 37.
- ❷ Kit perno/mozzo/distanziale - Rear pin/hub/spacer kit - Kit axe/moyeu/entretoise - Bausatz Welle/Nabe/Abstandhalter - Kit perno/cubo/distancidor.

C01

2



ASSIEME RUOTA ANTERIORE
FRONT WHEEL ASSEMBLY • ENSEMBLE ROUE AVANT
BAUGRUPPE VORDERRAD • CONJUNTO RUEDA DELANTERA

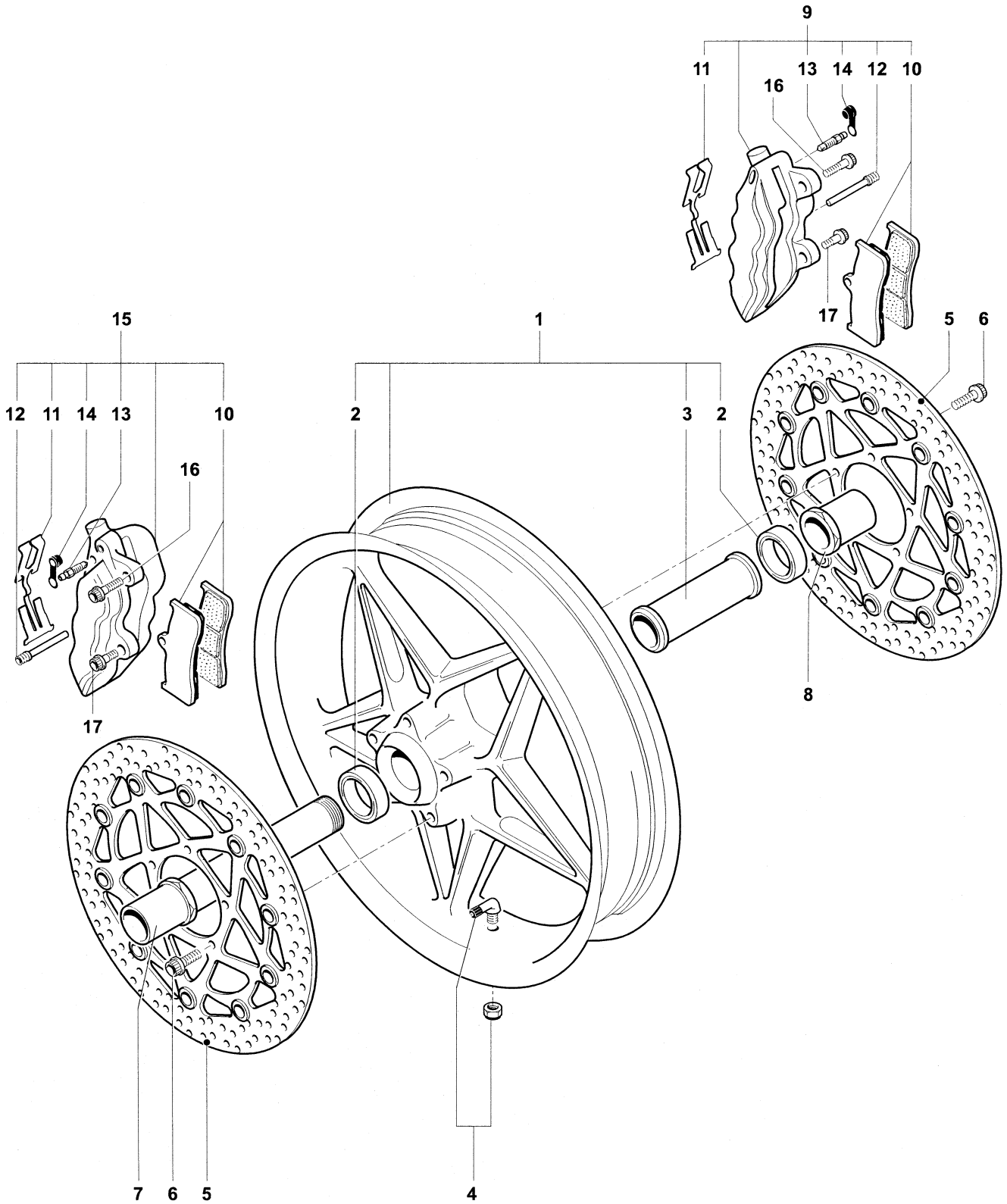

ASSIEME RUOTA ANTERIOREFRONT WHEEL ASSEMBLY • ENSEMBLE ROUE AVANT
BAUGRUPPE VORDERRAD • CONJUNTO RUEDA DELANTERA

N.	Code	Q.ty	Note	BRUTALE ORO	BRUTALE S	► I FRAME I ►	► I ENGINE I ►
1	800094628	1		•			
1	80A094632	1			•		
2	800090355	2		•	•		
3	800090356	1		•	•		
4	800091011	1		•	•		
5	800082758	2		•			
5	8A0082759	2			•		
6	8C0090426	10		•	•		
7	800082752	1		•	•		
8	800082750	1		•	•		
9	800094023	1		•	•		
10	800094024	2		•	•		
11	800092886	2		•	•		
12	800082743	2		•	•		
13	800089484	2		•	•		
14	800089491	2		•	•		
15	800094022	1		•	•		
16	8L0082751	2		•	•		
17	8H0082751	2		•	•		



ASSIEME PEDANA SINISTRA

LEFT-HAND FOOTREST ASSEMBLY • ENSEMBLE REPOSE-PIEDS GAUCHE
BAUGRUPPE LINKES FUSSBRETT • CONJUNTO ESTRIBO IZQUIERDO

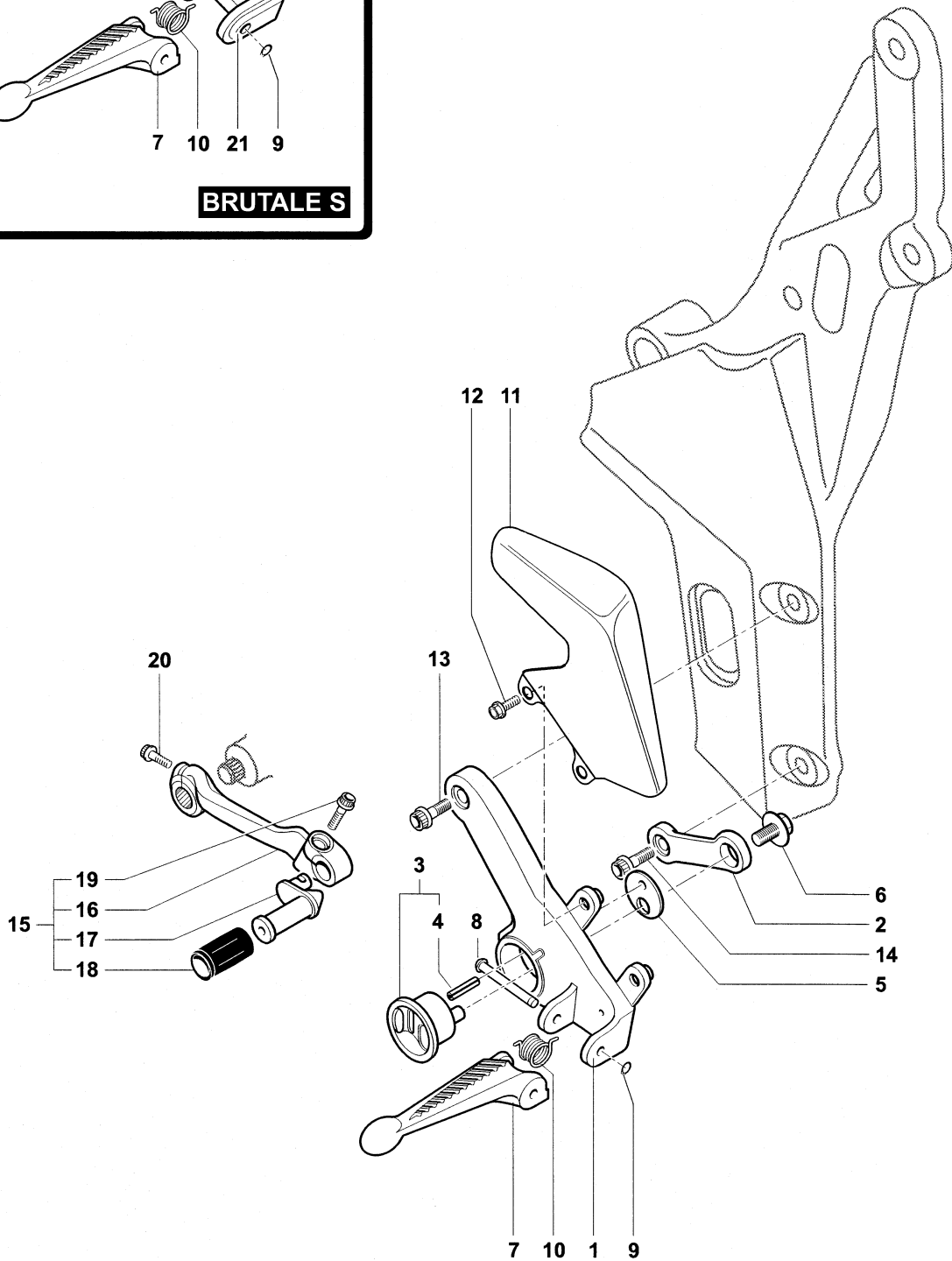
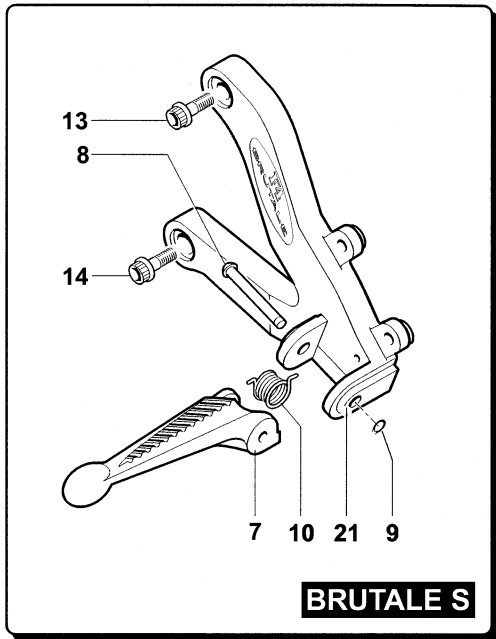

ASSIEME PEDANA SINISTRALEFT-HAND FOOTREST ASSEMBLY • ENSEMBLE REPOSE-PIEDS GAUCHE
BAUGRUPPE LINKES FUSSBRETT • CONJUNTO ESTRIBO IZQUIERDO

N.	Code	Q.ty	Note	BRUTALE ORO	BRUTALE S	► I FRAME I ►	► I ENGINE I ►
1	800089771	1		•			
2	800099124	1		•			
3	800092891	1		•			
4	800090314	1		•			
5	800089777	1		•			
6	800089778	1		•			
7	800087465	1		•	•		
8	800090416	1		•	•		
9	800090429	1		•	•		
10	800090418	1		•	•		
11	800089335	1		•	•		
12	800062725	2		•	•		
13	8G0090426	1		•	•		
14	8F0090426	1		•	•		
15	800090277	1		•	•		
16	800089759	1		•	•		
17	800089760	1		•	•		
18	800089298	1		•	•		
19	8G0090425	1		•	•		
20	8G0090425	1		•	•		
21	800099447	1			•		



ASSIEME PEDANA DESTRA

RIGHT-HAND FOOTREST ASSEMBLY • ENSEMBLE REPOSE-PIEDS DROIT
BAUGRUPPE RECHTES FUSSBRETT • CONJUNTO ESTRIBO DERECHO

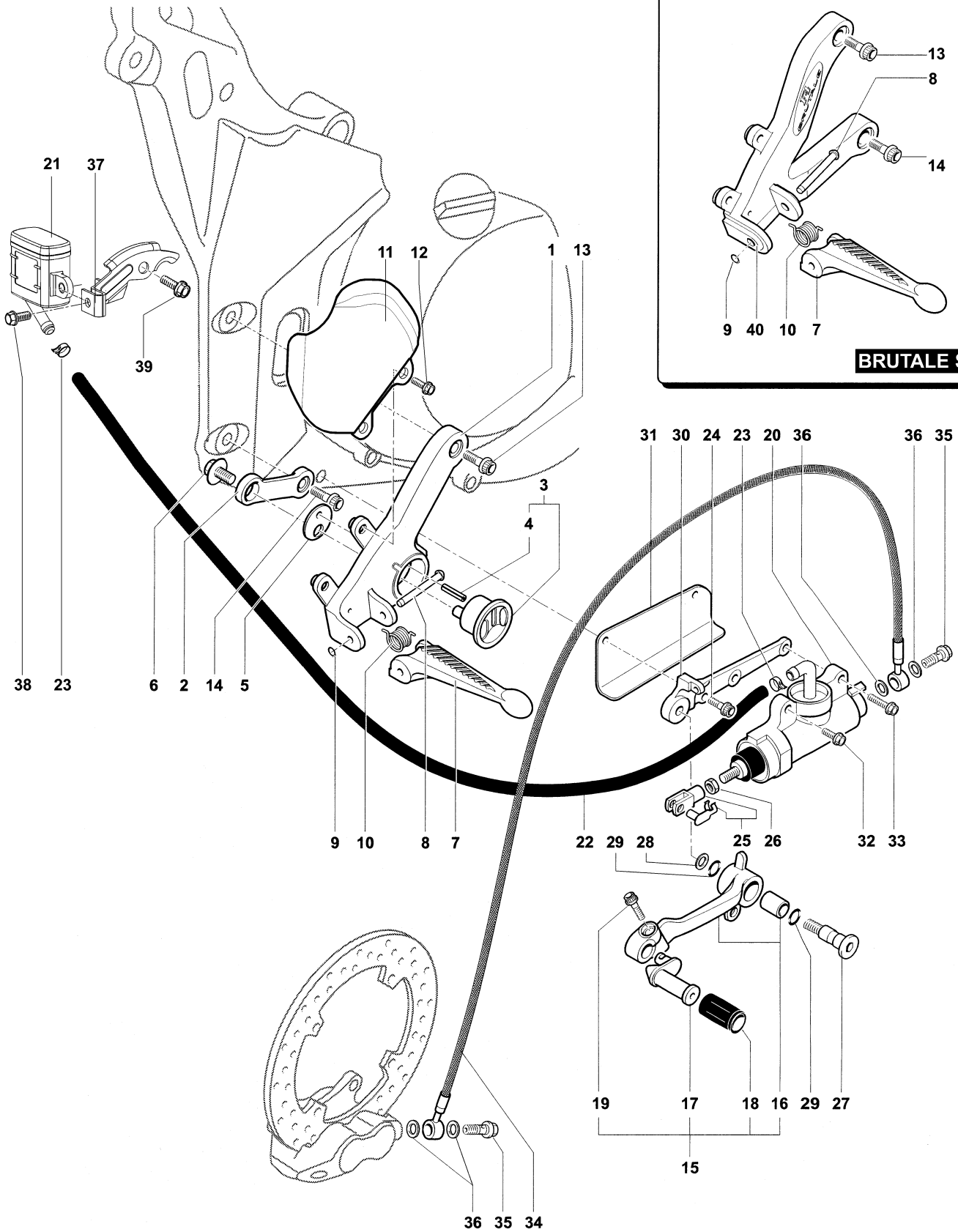

ASSIEME PEDANA DESTRA

 RIGHT-HAND FOOTREST ASSEMBLY • ENSEMBLE REPOSE-PIEDS DROIT
 BAUGRUPPE RECHTES FUSSBRETT • CONJUNTO ESTRIBO DERECHO



N.	Code	Q.ty	Note	BRUTALE ORO	BRUTALE S	► I FRAME I ►	► I ENGINE I ►
1	800089772	1		.			
2	800099124	1		.			
3	800092890	1		.			
4	800090314	1		.			
5	800089777	1		.			
6	800089778	1		.			
7	800087466	1		.	.		
8	800090416	1		.	.		
9	800090429	1		.	.		
10	800090418	1		.	.		
11	800099136	1		.	.		
12	800062725	2		.	.		
13	8G0090426	1		.	.		
14	8F0090426	1		.	.		
15	800090275	1		.	.		
16	800093314	1		.	.		
17	800089760	1		.	.		
18	800089298	1		.	.		
19	8G0090425	1		.	.		
20	800089313	1		.	.		
21	800090315	1		.	.		
22	8G0070266	1		.	.		
23	800070700	2		.	.		
24	8F0090426	1		.	.		
25	80A055757	1		.	.		
26	61N115062	1		.	.		
27	80A053548	1		.	.		
28	800090894	1		.	.		
29	800001199	2		.	.		
30	800089770	1		.	.		
31	800090312	1		.	.		
32	800062728	1		.	.		
33	8A0067545	1		.	.		
34	8000A1009	1		.	.		
35	800091692	2		.	.		
36	800021480	4		.	.		
37	800099341	1		.	.		
38	800062726	1		.	.		
39	8B0069056	1		.	.		
40	800099448	1		.	.		



ASSIEME MANUBRIO (LATO DESTRO)

HANDLEBAR ASSEMBLY (RIGHT SIDE) • ENSEMBLE GUIDON (CÔTÉ DROIT)

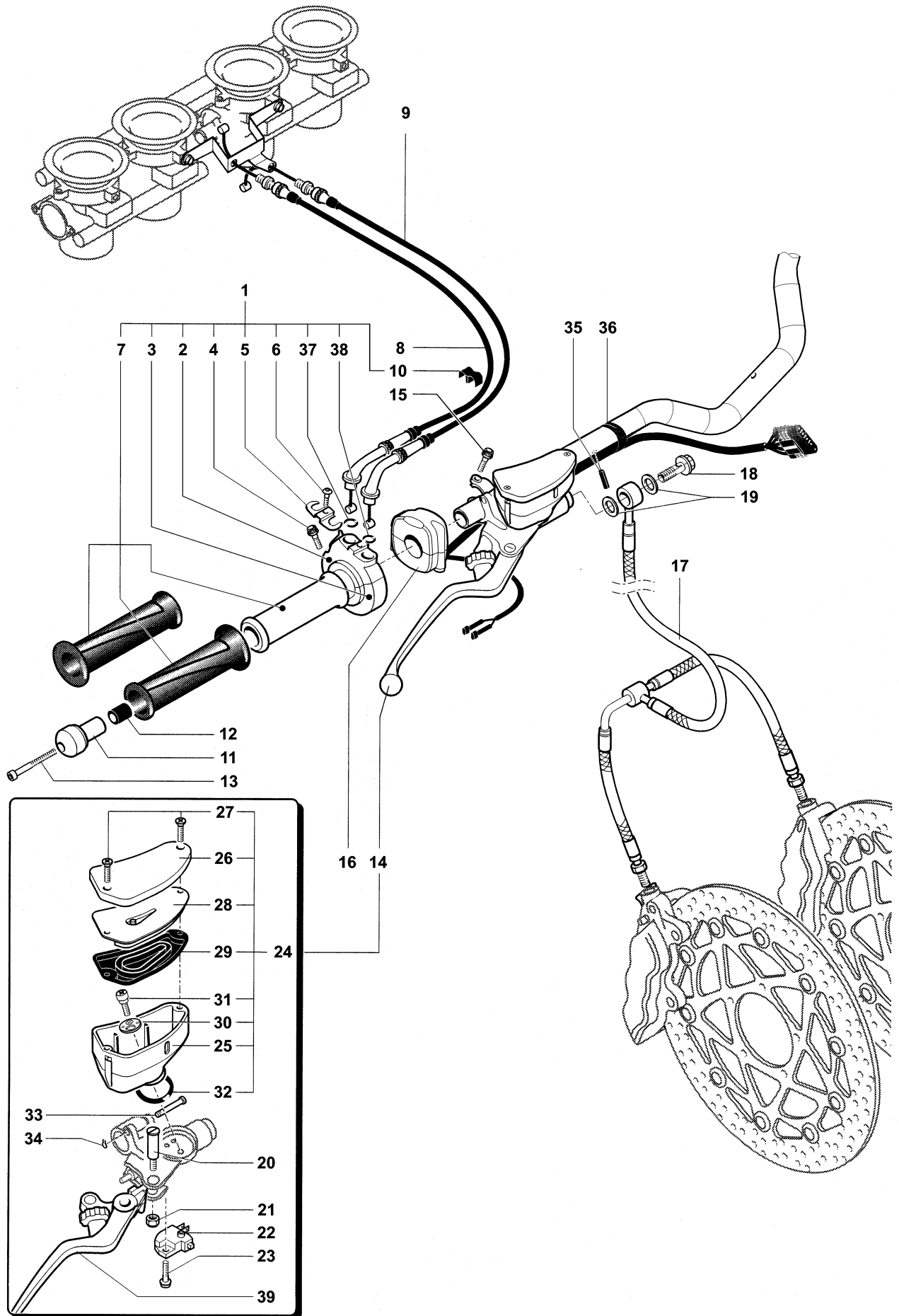
BAUGRUPPE LENKER (RECHTE SEITE) • CONJUNTO MANILLAR (LADO DERECHO)



ASSIEME MANUBRIO (LATO DESTRO)

 HANDLEBAR ASSEMBLY (RIGHT SIDE) • ENSEMBLE GUIDON (CÔTÉ DROIT)
 BAUGRUPPE LENKER (RECHTE SEITE) • CONJUNTO MANILLAR (LADO DERECHO)

N.	Code	Q.ty	Note	BRUTALE ORO	BRUTALE S	► I FRAME I ►	► I ENGINE I ►
1	800094640	1		•	•		
1	800095848	1	F	•	•		
2	800092894	1		•	•		
3	800090265	1		•	•		
3	800095847	1	F	•	•		
4	8H0090425	2		•	•		
5	800090266	1		•	•		
6	800093297	1		•	•		
7	800094529	1		•	•		
8	800098685	1		•	•		
9	800098686	1		•	•		
10	800092630	1		•	•		
11	8000A1402	1		•	•		
12	800090890	1		•	•		
13	60N102520	1		•	•		
14	800097902	1		•	•		
15	8J0090425	1		•	•		
16	8000A0920	1		•	•		
17	8000A3996	1		•	•		
18	800091692	1		•	•		
19	800021480	2		•	•		
20	800093299	1		•	•		
21	800093300	1		•	•		
22	800070864	1		•	•		
23	800070865	1		•	•		
24	800098722	1		•	•		
25	800097121	1		•	•		
26	800082728	1		•	•		
27	800093313	2		•	•		
28	800093302	1		•	•		
29	800093303	1		•	•		
30	800098962	1		•	•		
31	8000A1295	1		•	•		
32	800093306	1		•	•		
33	800082695	1		•	•		
34	800094643	1		•	•		
35	6AN155034	1		•	•		
36	800092248	1		•	•		
37	8000A2181	1		•	•		
38	8000A2180	1		•	•		
39	8000A3823	1		•	•		



ASSIEME MANUBRIO (LATO SINISTRO)

HANDLEBAR ASSEMBLY (LEFT SIDE) • ENSEMBLE GUIDON (CÔTÉ GAUCHE)
BAUGRUPPE LENKER (LINKE SEITE) • CONJUNTO MANILLAR (LADO IZQUIERDO)

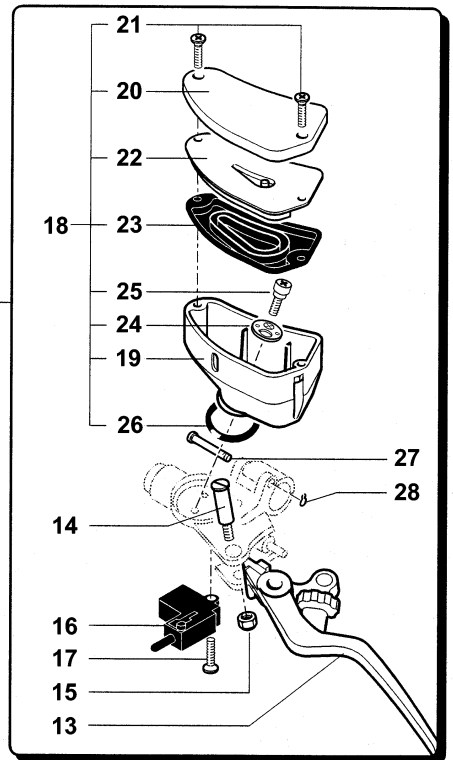
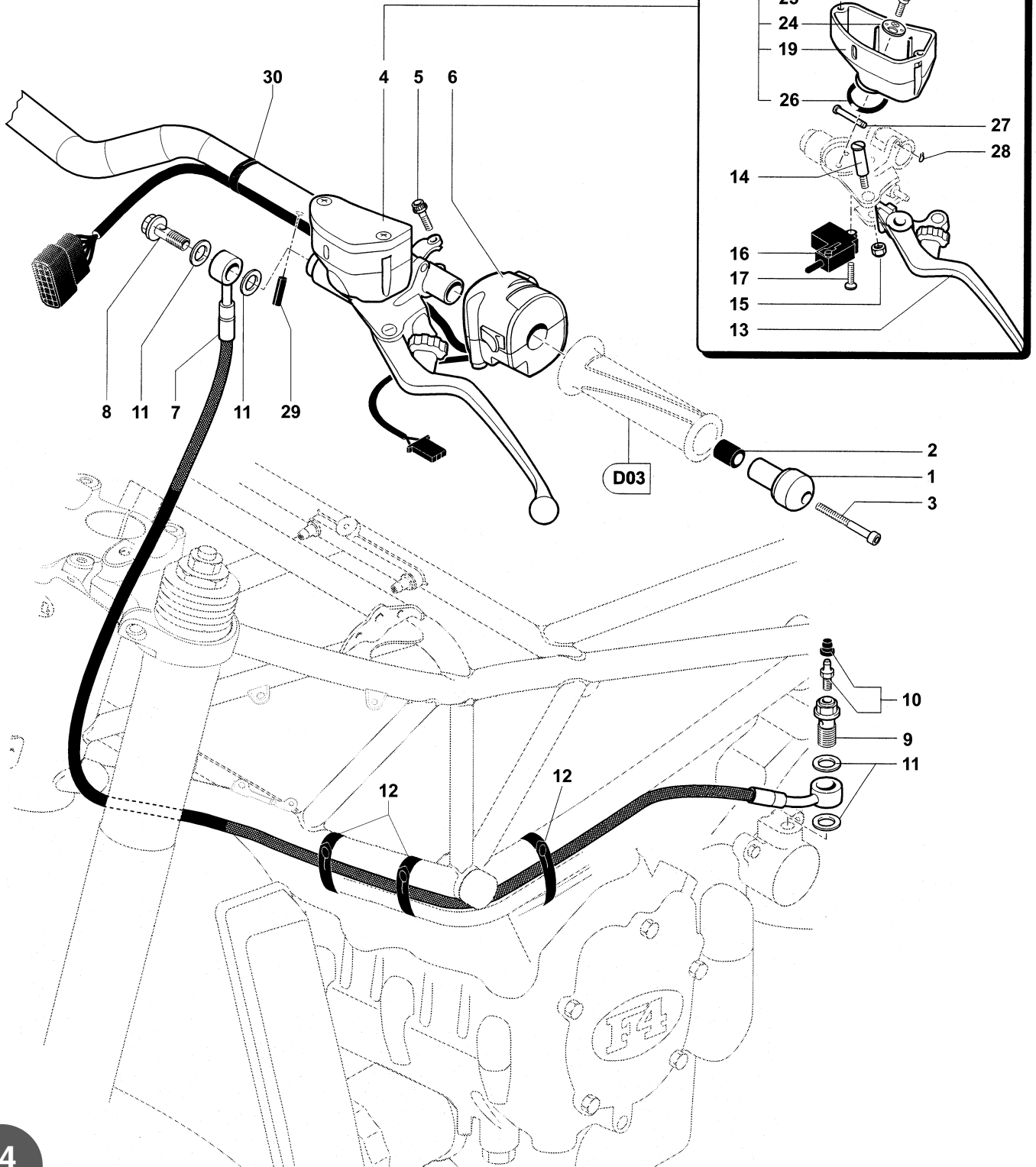

ASSIEME MANUBRIO (LATO SINISTRO)

HANDLEBAR ASSEMBLY (LEFT SIDE) • ENSEMBLE GUIDON (CÔTÉ GAUCHE)

BAUGRUPPE LENKER (LINKE SEITE) • CONJUNTO MANILLAR (LADO IZQUIERDO)



N.	Code	Q.ty	Note	BRUTALE ORO	BRUTALE S	► I FRAME I ►	► I ENGINE I ►
1	8000A1402	1		•	•		
2	800090890	1		•	•		
3	60N102520	1		•	•		
4	800097903	1		•	•		
5	8J0090425	1		•	•		
6	8000A0922	1		•	•		
7	800098697	1		•	•		
8	800091692	1		•	•		
9	800091691	1		•	•		
10	800033552	1		•	•		
11	800021480	4		•	•		
12	800092248	3		•	•		
13	800093298	1		•	•		
14	800093299	1		•	•		
15	800093300	1		•	•		
16	800093307	1		•	•		
17	800093313	1		•	•		
18	800098723	1		•	•		
19	800097122	1		•	•		
20	800093310	1		•	•		
21	800093313	2		•	•		
22	800093311	1		•	•		
23	800093312	1		•	•		
24	800098962	1		•	•		
25	8000A1295	1		•	•		
26	800093306	1		•	•		
27	800082695	1		•	•		
28	800094643	1		•	•		
29	6AN155034	1		•	•		
30	800092248	1		•	•		



SERRATURE
LOCKS • VERROUILLAGES
SCHLÖSSER • CERRADURAS

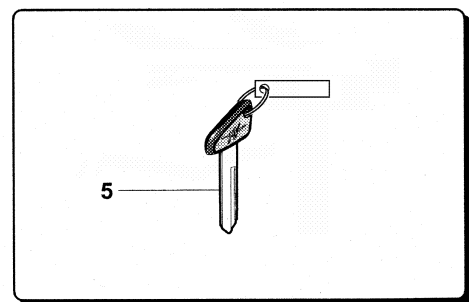
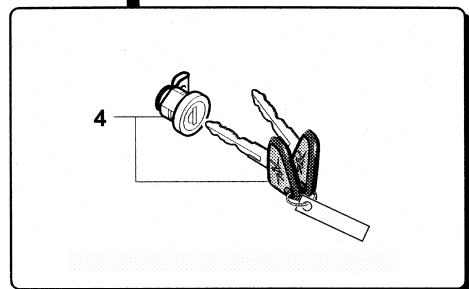
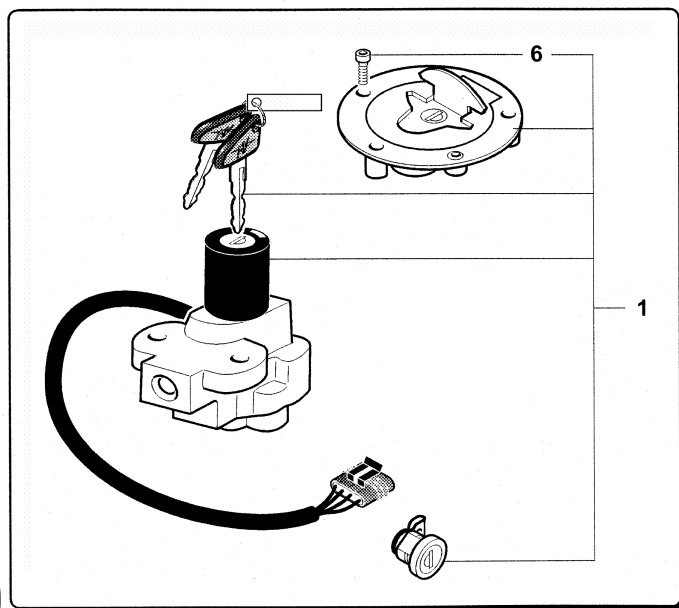
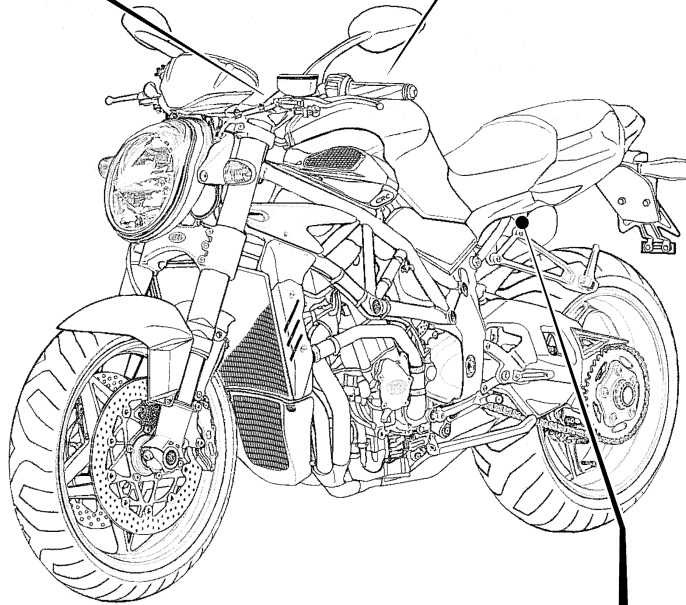
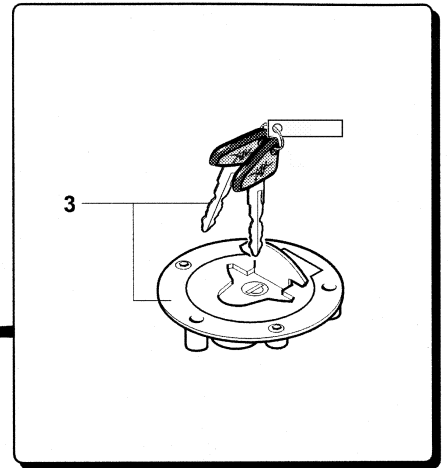
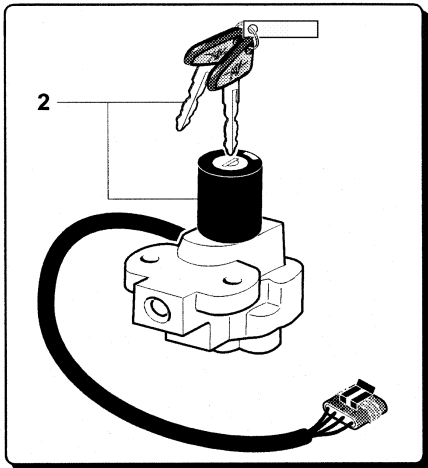

SERRATURELOCKS • VERROUILLAGES
SCHLÖSSER • CERRADURAS

N.	Code	Q.ty	Note	BRUTALE ORO	BRUTALE S	►I FRAME I►	►I ENGINE I►
1	800090249	1		•	•		
2	800093339	1		•	•		
3	800093340	1		•	•		
4	800093341	1		•	•		
5	800093338	1		•	•		
6	8A0066531	3		•	•		



ASSIEME CARENATURE

FAIRING ASSEMBLY • ENSEMBLE CARÉNAGE

BAUGRUPPE KAROSSERIE UND VERKLEIDUNG • CONJUNTO CARENADOS

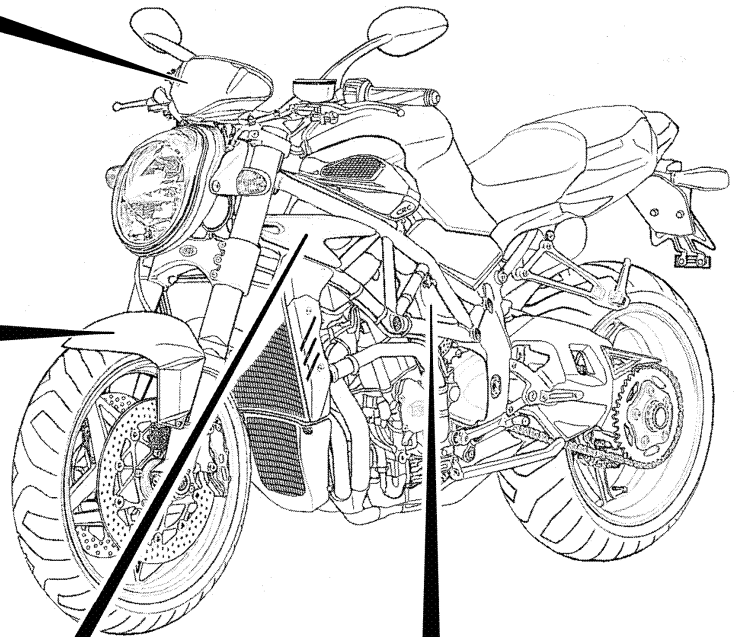
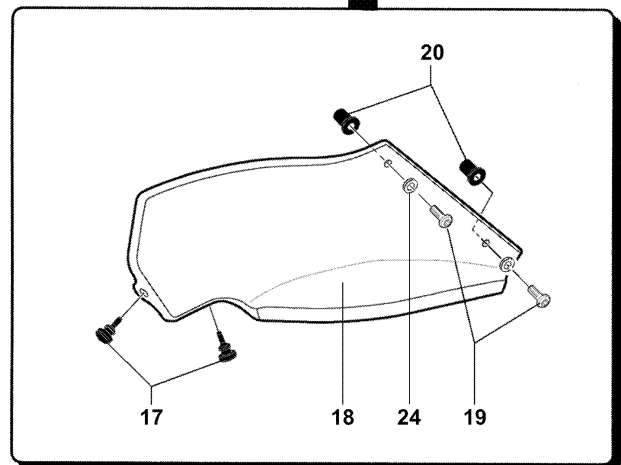
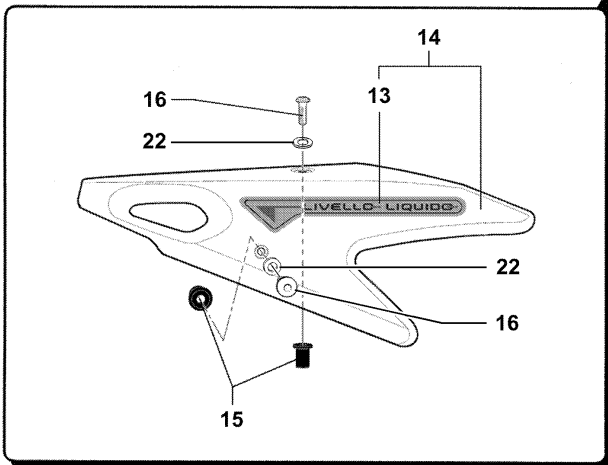
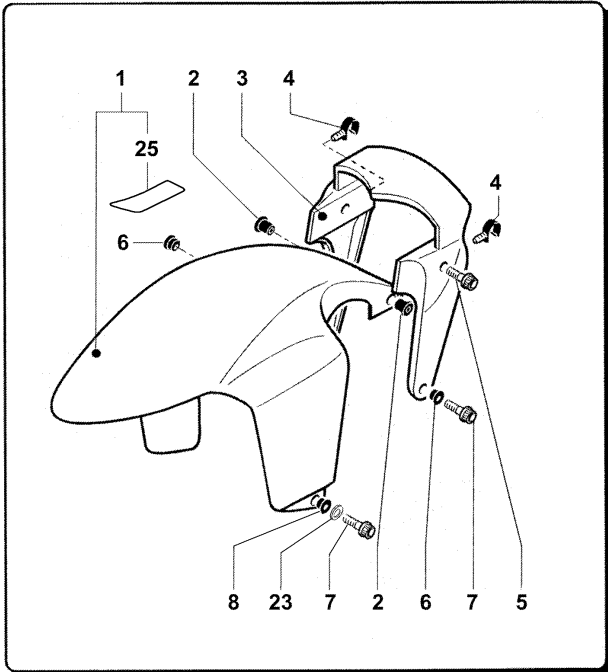
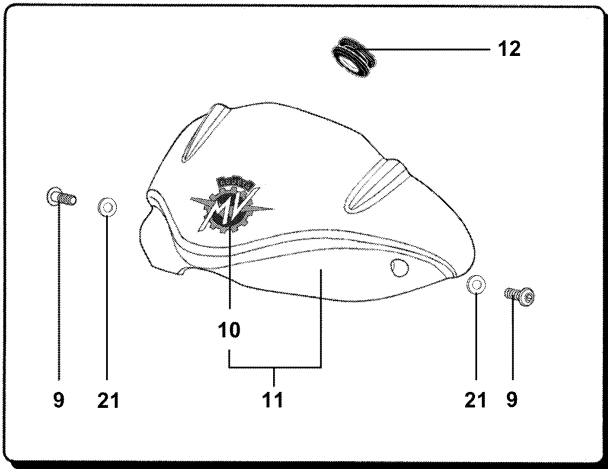

ASSIEME CARENATURE

FAIRING ASSEMBLY • ENSEMBLE CARÉNAGE

BAUGRUPPE KAROSSERIE UND VERKLEIDUNG • CONJUNTO CARENADOS



N.	Code	Q.ty	Note	BRUTALE ORO	BRUTALE S	► I FRAME I ►	► I ENGINE I ►
1	8000A5241	1		.			
1	80G0A5240	1	A D		.		
1	80E0A5240	1	B		.		
1	80H0A5240	1	C		.		
2	800048245	2		.	.		
3	800098328	1		.	.		
4	800091005	2		.	.		
5	8M0090425	2		.	.		
6	800092670	2		.	.		
7	8D0090425	4		.	.		
8	800092670	2			.		
9	8A0090901	2		.	.		
10	80B090316	1		.			
10	800090316	1	A		.		
10	80B090316	1	B C D		.		
11	800099323	1		.			
11	800099433	1	A		.		
11	80A099433	1	B C D		.		
12	800089293	1		.	.		
13	800098829	1		.	.		
14	800099135	1		.	.		
15	800091022	2		.	.		
16	8A0090901	2		.	.		
17	800095828	2		.	.		
18	80A098863	1		.			
18	800099407	1			.		
19	8A0090901	2		.	.		
20	800091022	2		.	.		
21	800092882	2		.	.		
22	800092882	2		.	.		
23	800062738	2		.			
24	800092882	2		.			
25	8000A5239	1		.	.		

A Versione Rossa - Red version - Version Rouge - Rote Version - Versión Roja.

B Versione Nera - Black version - Version Noire - Schwarze Version - Versión Negra.

C Versione Argento - Silver version - Version Argent - Silber Version - Versión Plata.

D Versione Rosso/Nera - Red/Black version - Version Rouge/Noire - Rot/Schwarze Version - Versión Rojo/Negra.

E01

4



ASSIEME CARENATURE

FAIRING ASSEMBLY • ENSEMBLE CARÉNAGE

BAUGRUPPE KAROSSERIE UND VERKLEIDUNG • CONJUNTO CARENADOS

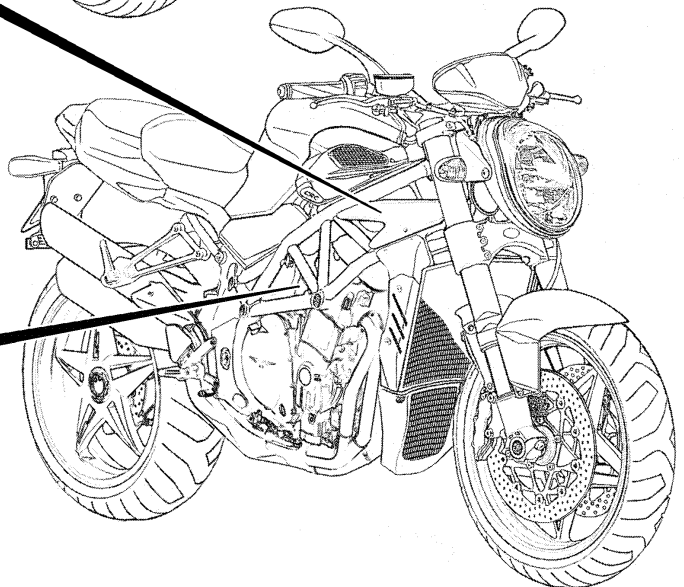
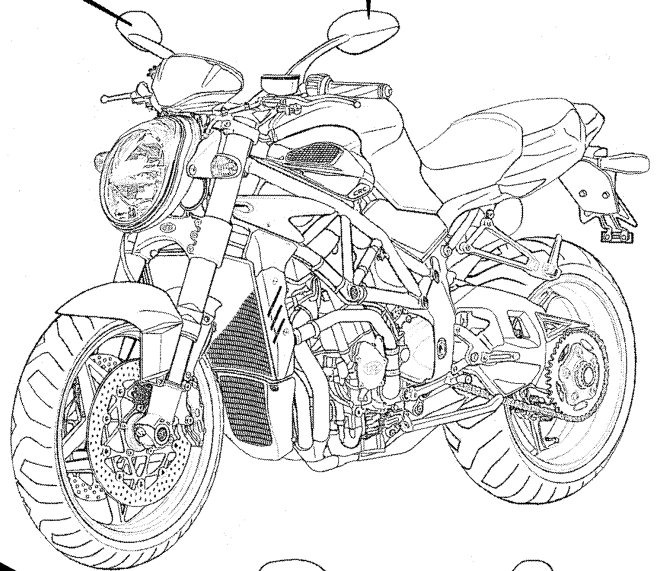
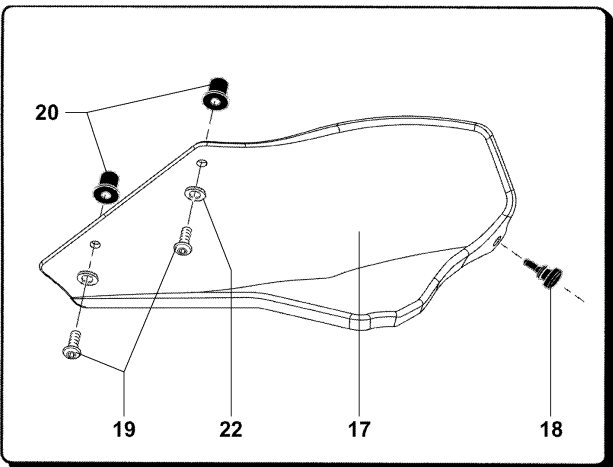
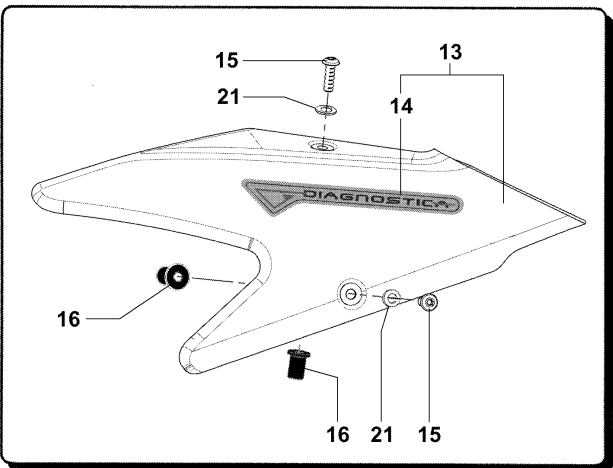
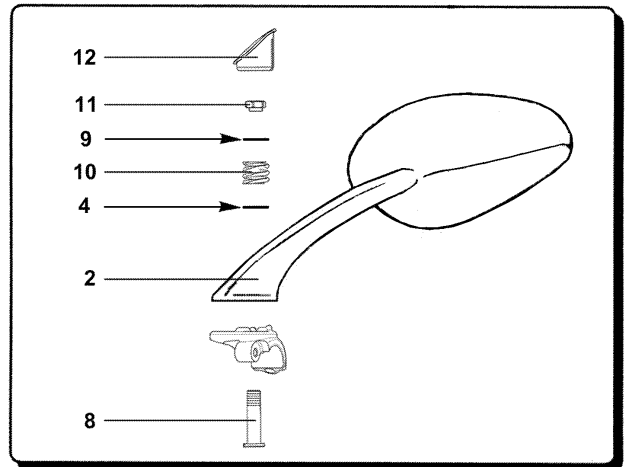
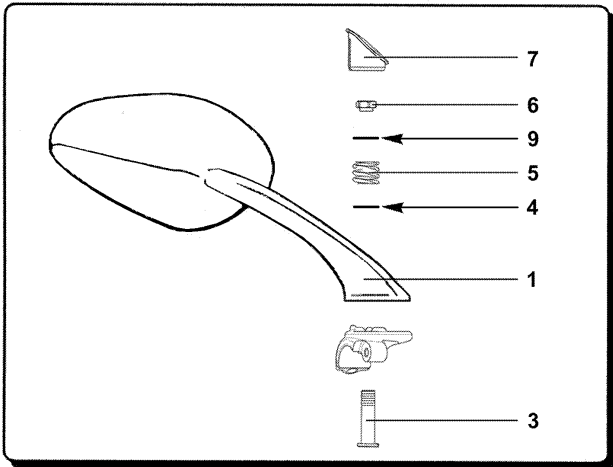

ASSIEME CARENATURE

FAIRING ASSEMBLY • ENSEMBLE CARÉNAGE

BAUGRUPPE KAROSSERIE UND VERKLEIDUNG • CONJUNTO CARENADOS



N.	Code	Q.ty	Note	BRUTALE ORO	BRUTALE S	► I FRAME I ►	► I ENGINE I ►
1	80A098338	1		•	•		
2	80A098339	1		•	•		
3	800099289	1		•	•		
4	8000A1040	2		•	•		
5	800099290	1		•	•		
6	800099291	1		•	•		
7	800099292	1		•	•		
8	800099289	1		•	•		
9	8000A2761	2		•	•		
10	800099290	1		•	•		
11	800099291	1		•	•		
12	8000A1763	1		•	•		
13	800099134	1		•	•		
13	8000A1262	1			•		
14	800099133	1		•			
14	8000A1245	1			•		
15	8A0090901	2		•	•		
16	800091022	2		•	•		
17	80A098862	1		•			
17	800099406	1			•		
18	800095828	1		•	•		
19	8A0090901	2		•	•		
20	800091022	2		•	•		
21	800092882	2		•	•		
22	800092882	2		•			



ASSIEME AIRBOX
AIRBOX ASSEMBLY • ENSEMBLE AIRBOX
BAUGRUPPE AIRBOX • CONJUNTO AIRBOX

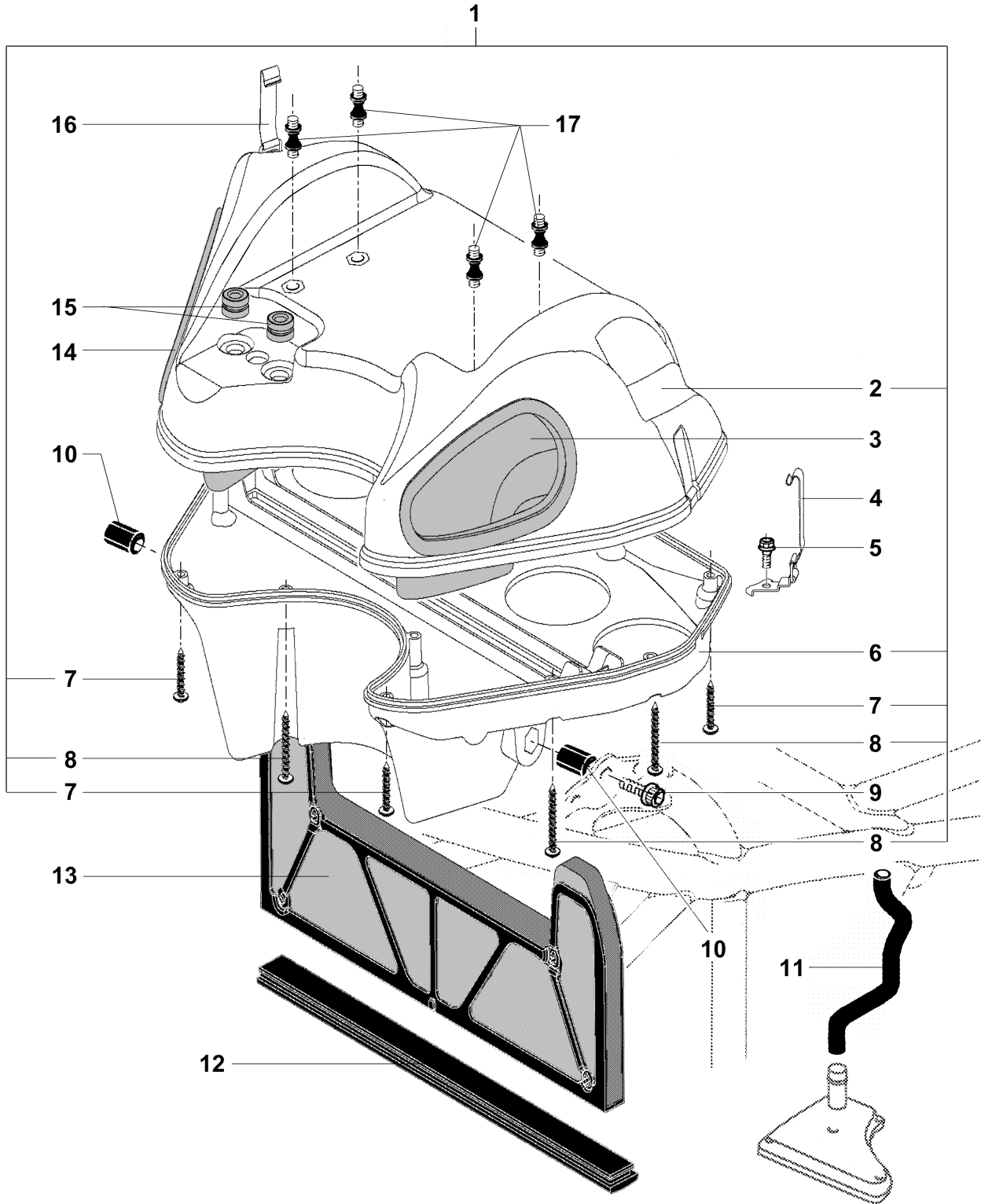

ASSIEME AIRBOXAIRBOX ASSEMBLY • ENSEMBLE AIRBOX
BAUGRUPPE AIRBOX • CONJUNTO AIRBOX

N.	Code	Q.ty	Note	BRUTALE ORO	BRUTALE S	► I FRAME I ►	► I ENGINE I ►
1	800097908	1		•	•		
2	800097907	1		•	•		
3	800099339	1		•	•		
4	800099337	1		•	•		
5	8A0090424	2		•	•		
6	800097906	1		•	•		
7	8BA084658	5		•	•		
8	8DA084658	8		•	•		
9	8G0090425	2		•	•		
10	800091008	2		•	•		
11	800098873	1		•	•		
12	800097910	1		•	•		
13	800099331	1		•	•		
14	800099340	1		•	•		
15	800089293	2		•	•		
16	800099336	1		•	•		
17	800090913	4		•	•		



ASSIEME SERBATOIO BENZINA
FUEL TANK ASSEMBLY • ENSEMBLE RÉSERVOIR DE CARBURANT
BAUGRUPPE TANK • CONJUNTO DEPÓSITO GASOLINA

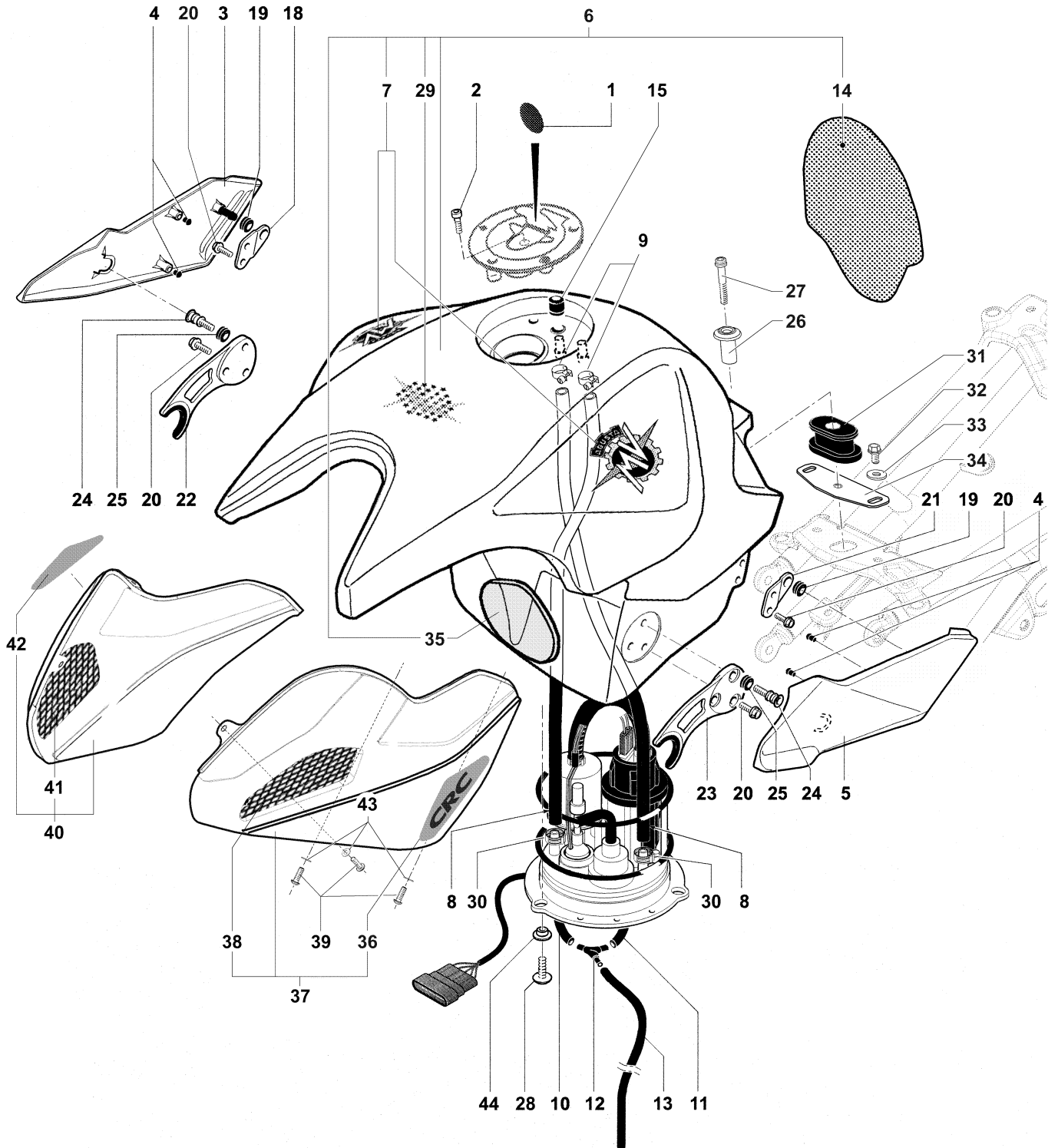

ASSIEME SERBATOIO BENZINA

 FUEL TANK ASSEMBLY • ENSEMBLE RÉSERVOIR DE CARBURANT
 BAUGRUPPE TANK • CONJUNTO DEPÓSITO GASOLINA

N.	Code	Q.ty	Note	BRUTALE ORO	BRUTALE S	► I FRAME I ►	► I ENGINE I ►
1	800092664	1		•	•		
2	8D0066531	1		•	•		
3	80A098856	1		•			
3	80A098314	1			•		
4	800090978	4		•	•		
5	80A098857	1		•			
5	80A098313	1			•		
6	800099325	1		•			
6	800099325	1	A		•		
6	80A099325	1	B		•		
6	8000A5184	1	C		•		
6	80A0A5184	1	D		•		
7	80B098832	2		•			
7	80B098832	2	A		•		
7	80A098832	2	B D		•		
7	80C098832	2	C		•		
8	800090940	2		•	•		
9	8B0091687	2		•	•		
10	800091695	1	1	•	•		
11	800091690	1	1	•	•		
12	800091689	1	1	•	•		
13	800091688	1		•	•		
14	800099324	1		•			
14	800099324	1	A B		•		
14	8000A5183	1	C		•		
14	80A0A5183	1	D		•		
15	800090923	1		•	•		
18	800090307	1		•	•		
19	800089293	2		•	•		
20	800062727	8		•	•		
21	800090981	1		•	•		
22	800089784	1		•	•		
23	800089785	1		•	•		
24	800090977	2		•	•		
25	800089293	2		•	•		
26	800099401	1		•	•		
27	8M0090425	1		•	•		
28	8A0089786	9		•	•		
29	80B090321	1		•			
29	80B090321	1	A B D		•		
29	80D090321	1	C		•		
30	8C0092256	2		•	•		
31	800099326	1		•	•		
32	800062725	2		•	•		
33	800056359	2		•	•		
34	800098720	1		•	•		
35	8000A0903	1		•	•		
36	800098827	1		•	•		
37	800099285	1		•			
37	800099429	1			•		
38	800098705	1		•	•		
39	8B0090901	6		•	•		
40	800099284	1		•			
40	800099430	1			•		

A Versione Rossa - Red version - Version Rouge - Rote Version - Versión Roja.

B Versione Nera - Black version - Version Noire - Schwarze Version - Versión Negra.

C Versione Argento - Silver version - Version Argent - Silber Version - Versión Plata.

D Versione Rosso/Nera - Red/Black version - Version Rouge/Noire - Rot/Schwarze Version - Versión Rojo/Negra.

1 Esclusi gli USA (vedi tavola K02) - USA excluded (see table K02) - Sauf les USA (voir planche K02) - Ausschließlich USA (siehe Tafel K02)
 - Excluidos los USA (ver tabla K02).



ASSIEME SERBATOIO BENZINA
FUEL TANK ASSEMBLY • ENSEMBLE RÉSERVOIR DE CARBURANT
BAUGRUPPE TANK • CONJUNTO DEPÓSITO GASOLINA

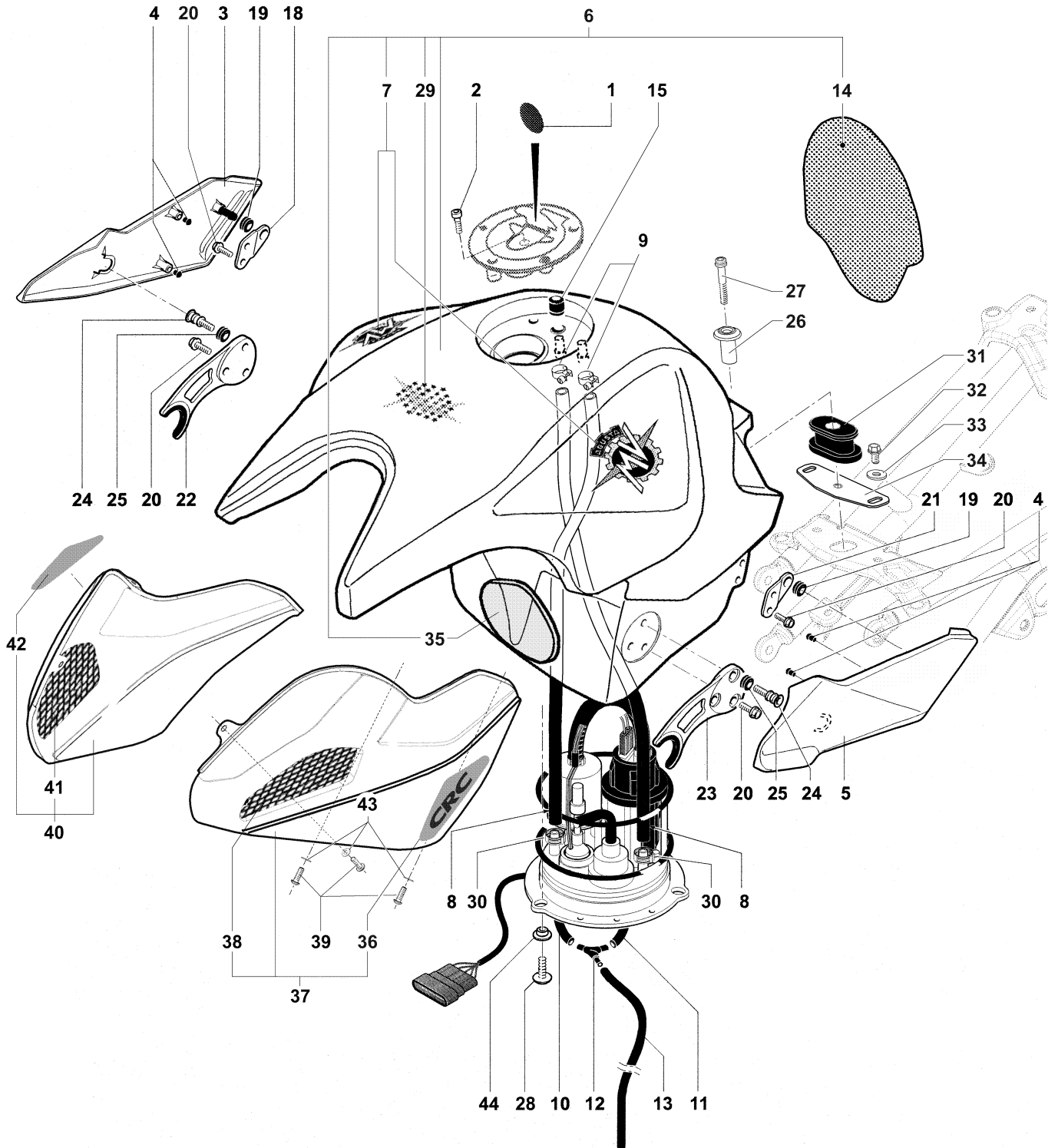

ASSIEME SERBATOIO BENZINAFUEL TANK ASSEMBLY • ENSEMBLE RÉSERVOIR DE CARBURANT
BAUGRUPPE TANK • CONJUNTO DEPÓSITO GASOLINA

N.	Code	Q.ty	Note	BRUTALE ORO	BRUTALE S	► I FRAME I ►	► I ENGINE I ►
41	800098704	1		•	•		
42	800098828	1		•	•		
43	800092882	6		•	•		
44	800090392	3		•	•		





ASSIEME CODONE

REAR FAIRING ASSEMBLY • ENSEMBLE CARÉNAGE DE SELLE
BAUGRUPPE HECK • CONJUNTO COLÍN

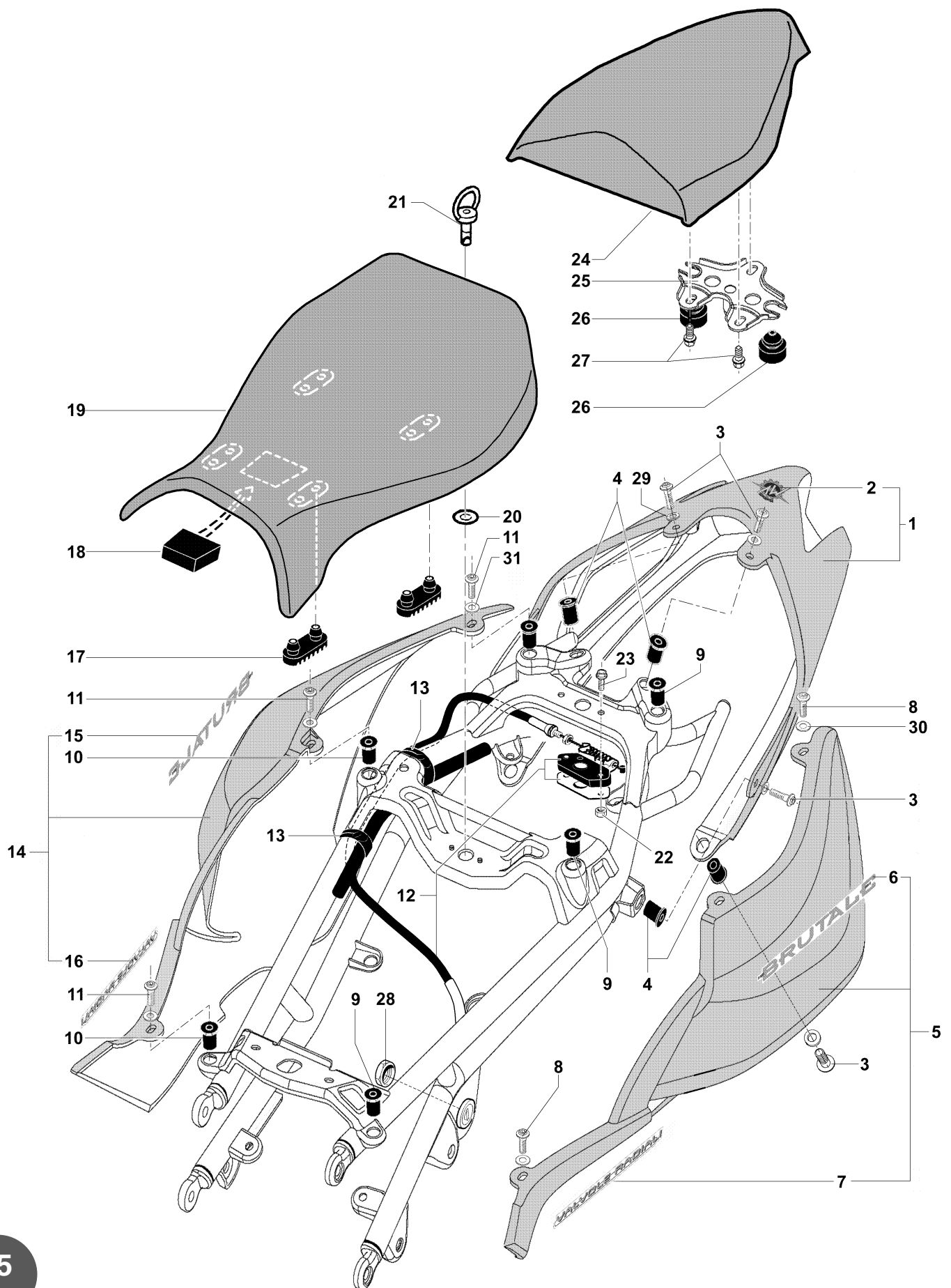

ASSIEME CODONE

 REAR FAIRING ASSEMBLY • ENSEMBLE CARÉNAGE DE SELLE
 BAUGRUPPE HECK • CONJUNTO COLÍN

N.	Code	Q.ty	Note	BRUTALE ORO	BRUTALE S	► I FRAME I ►	► I ENGINE I ►
1	800099288	1		.			
1	800099431	1	A		.		
1	80A099431	1	B C D		.		
2	80B090316	1		.			
2	800090316	1	A		.		
2	80B090316	1	B C D		.		
3	800089786	6		.	.		
4	800048245	6		.	.		
5	800099287	1		.			
5	800099287	1	A D		.		
5	80A099287	1	B		.		
5	80B099287	1	C		.		
6	80A098831	1		.			
6	80A098831	1	A B D		.		
6	80B098831	1	C		.		
7	800098830	1		.			
7	800098830	1	A B D		.		
7	80A098830	1	C		.		
8	800089786	3		.	.		
9	800048245	3		.	.		
10	800048245	3		.	.		
11	800089786	3		.	.		
12	800099143	1		.	.		
13	800092247	2		.	.		
14	800099286	1		.			
14	800099286	1	A D		.		
14	80A099286	1	B		.		
14	80B099286	1	C		.		
15	80A098831	1		.			
15	80A098831	1	A B D		.		
15	80B098831	1	C		.		
16	800098830	1		.			
16	800098830	1	A B D		.		
16	80A098830	1	C		.		
17	800090380	4		.	.		
18	800094505	1		.	.		
19	800099116	1		.			
19	80A099116	1	A B D		.		
19	80B099116	1	C		.		
20	800069149	1		.	.		
21	800069148	1		.	.		
22	800056443	2		.	.		
23	8A0067997	2		.	.		
24	800099118	1		.			
24	800099118	1	A D		.		
24	80A099118	1	B		.		
24	80B099118	1	C		.		
25	8000A9317	1		.	.		
26	800041039	2		.	.		
27	800062725	3		.	.		
28	800090250	1		.	.		
29	800089751	6		.	.		
30	800089751	3		.	.		
31	800089751	3		.	.		

A Versione Rossa - Red version - Version Rouge - Rote Version - Versión Roja.

B Versione Nera - Black version - Version Noire - Schwarze Version - Versión Negra.

C Versione Argento - Silver version - Version Argent - Silber Version - Versión Plata.

D Versione Rosso/Nera - Red/Black version - Version Rouge/Noire - Rot/Schwarze Version - Versión Rojo/Negra.

E05

5



IMPIANTO ELETTRICO
ELECTRIC SYSTEM • INSTALLATION ÉLECTRIQUE
ELEKTRISCHE ANLAGE • INSTALACIÓN ELÉCTRICA

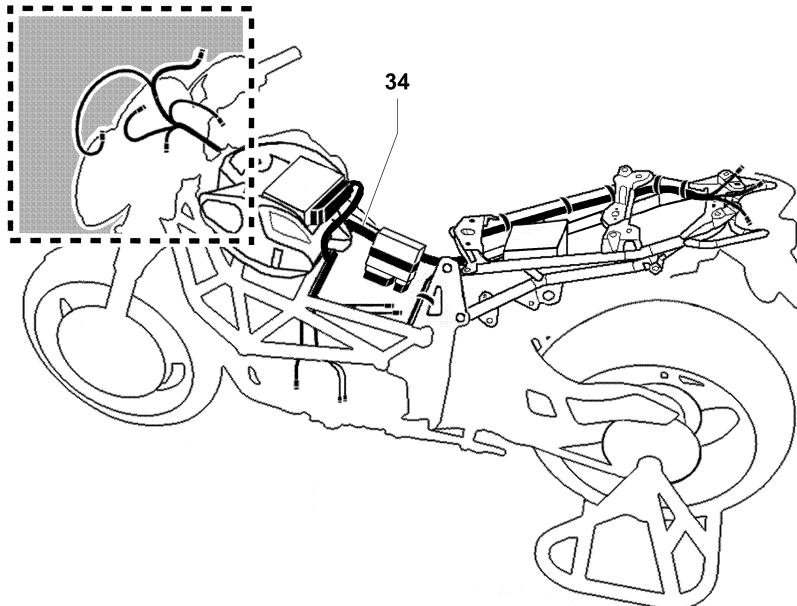
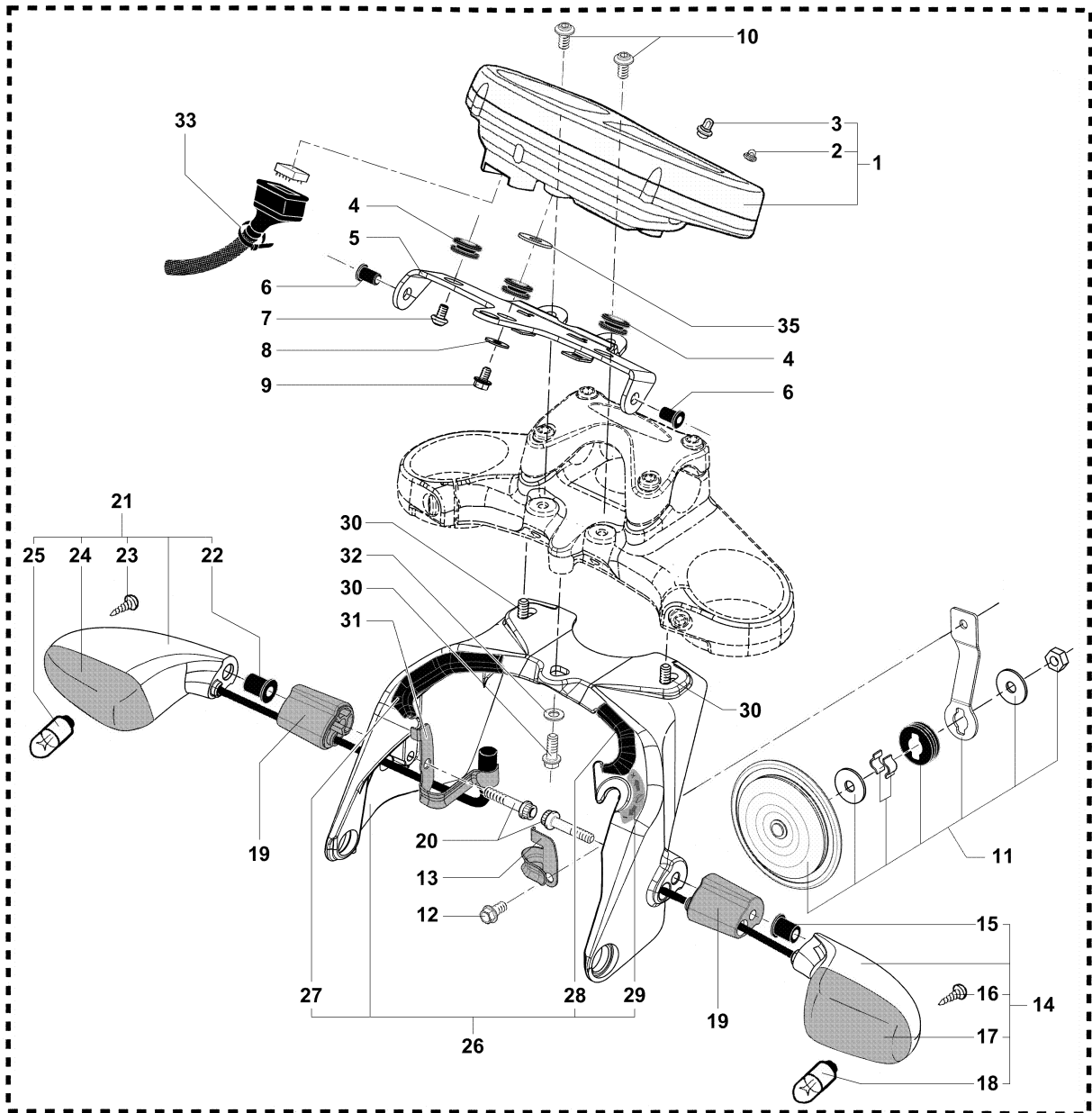



N.	Code	Q.ty	Note	BRUTALE ORO	BRUTALE S	► I FRAME I ►	► I ENGINE I ►
1	800097101	1		•	•		
2	800094861	1		•	•		
3	800094860	1		•	•		
4	800090239	3		•	•		
5	800099251	1		•	•		
6	800091022	2		•	•		
7	800092659	2		•	•		
8	62N115548	1		•	•		
9	8D0067997	1		•	•		
10	8A0089786	2		•	•		
11	800099114	1		•	•		
12	8H0067545	1		•	•		
13	800099281	1		•	•		
14	8A0090372	1		•	•		
15	800048245	1		•	•		
16	800093416	1		•	•		
17	800093336	1		•	•		
18	800036726	1		•	•		
19	800099376	2	USA	•	•		
20	8M0090425	2		•	•		
20	60N102520	2	USA	•	•		
21	8A0090373	1		•	•		
22	800048245	1		•	•		
23	800093416	1		•	•		
24	800093337	1		•	•		
25	800036726	1		•	•		
26	800099277	1		•	•		
27	800098846	1		•	•		
28	800098847	1		•	•		
29	800099405	1		•	•		
30	800062727	3		•	•		
31	800099282	1		•	•		
32	8C0037003	3		•	•		
33	800092661	1		•	•		
34	800099267	1		•	•		
35	800090894	1		•	•		



PROIETTORE ANTERIORE
FRONT HEADLIGHT • PROJECTEUR AVANT
SCHEINWERFER • PROYECTOR DELANTERO

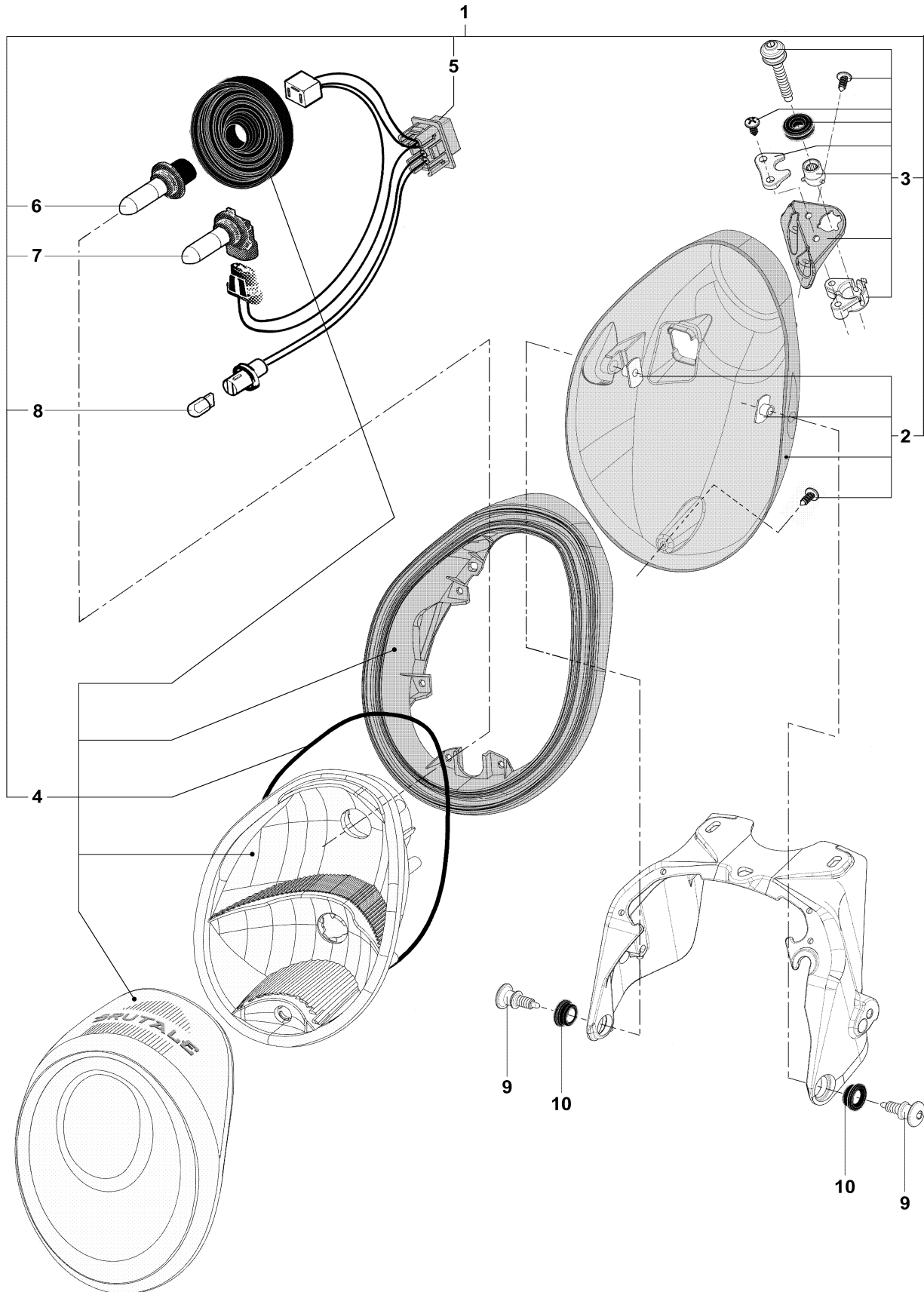

PROIETTORE ANTERIORE
 FRONT HEADLIGHT • PROJECTEUR AVANT
 SCHEINWERFER • PROYECTOR DELANTERO



N.	Code	Q.ty	Note	BRUTALE ORO	BRUTALE S	► I FRAME I ►	► I ENGINE I ►
1	800097124	1	①	•	•		
1	800098964	1	②	•	•		
1	800098965	1	USA	•	•		
2	8000A1770	1		•	•		
3	800097126	1		•	•		
4	8000A1771	1	①	•	•		
4	8000A1785	1	②	•	•		
4	8000A1786	1	USA	•	•		
5	8000A1772	1		•	•		
6	8000A1773	1		•	•		
7	8000A1774	1		•	•		
8	800036230	1		•	•		
9	800097113	2		•	•		
10	800097112	2		•	•		

① Per guida a destra - For right-hand drive - Pour conduite à droite - Für Rechtslenkung - Para conducción a la derecha
 ② Per guida a sinistra - For left-hand drive - Pour conduite à gauche - Für Linkslenkung - Para conducción a la izquierda



IMPIANTO ELETTRICO
ELECTRIC SYSTEM • INSTALLATION ÉLECTRIQUE
ELEKTRISCHE ANLAGE • INSTALACIÓN ELÉCTRICA

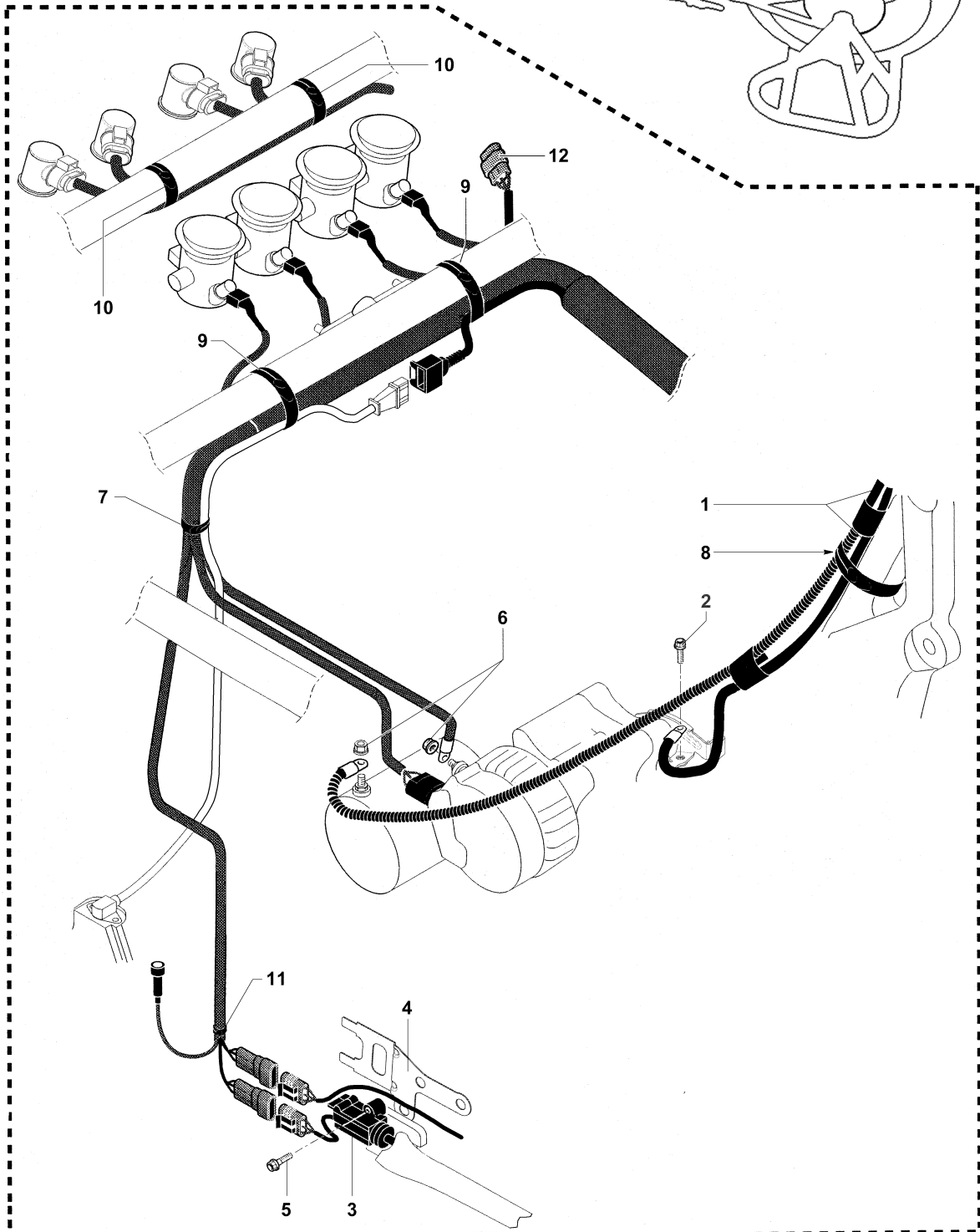
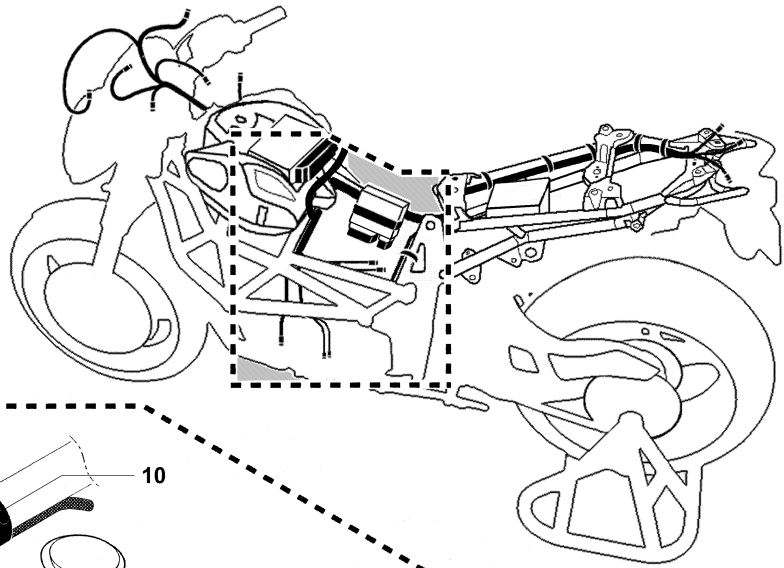

IMPIANTO ELETTRICOELECTRIC SYSTEM • INSTALLATION ÉLECTRIQUE
ELEKTRISCHE ANLAGE • INSTALACIÓN ELÉCTRICA

N.	Code	Q.ty	Note	BRUTALE ORO	BRUTALE S	►I FRAME I►	►I ENGINE I►
1	800099268	1		•	•		
2	8SA067545	1		•	•		
3	800090375	1		•	•		
4	800099141	1		•	•		
5	8H0090424	2		•	•		
6	800037901	2		•	•		
7	800053724	1		•	•		
8	800092247	1		•	•		
9	800092248	2		•	•		
10	800092248	2		•	•		
11	800092668	1		•	•		
12	8B0089516	1		•	•		



IMPIANTO ELETTRICO
ELECTRIC SYSTEM • INSTALLATION ÉLECTRIQUE
ELEKTRISCHE ANLAGE • INSTALACIÓN ELÉCTRICA

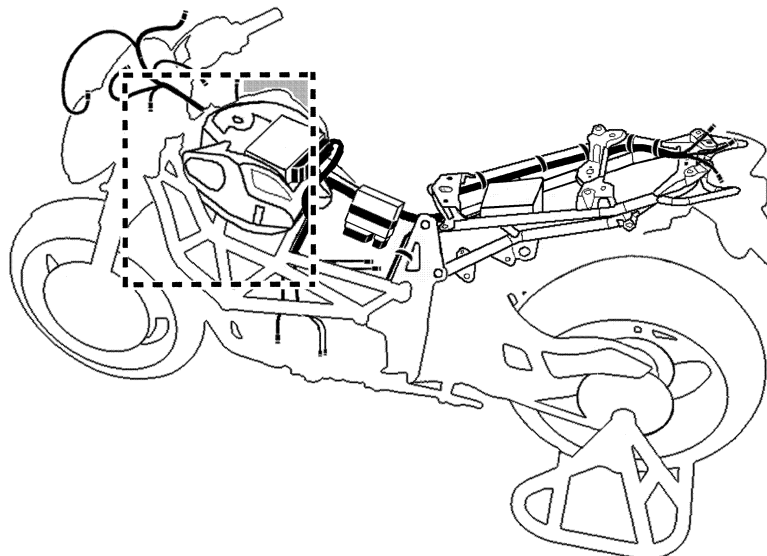
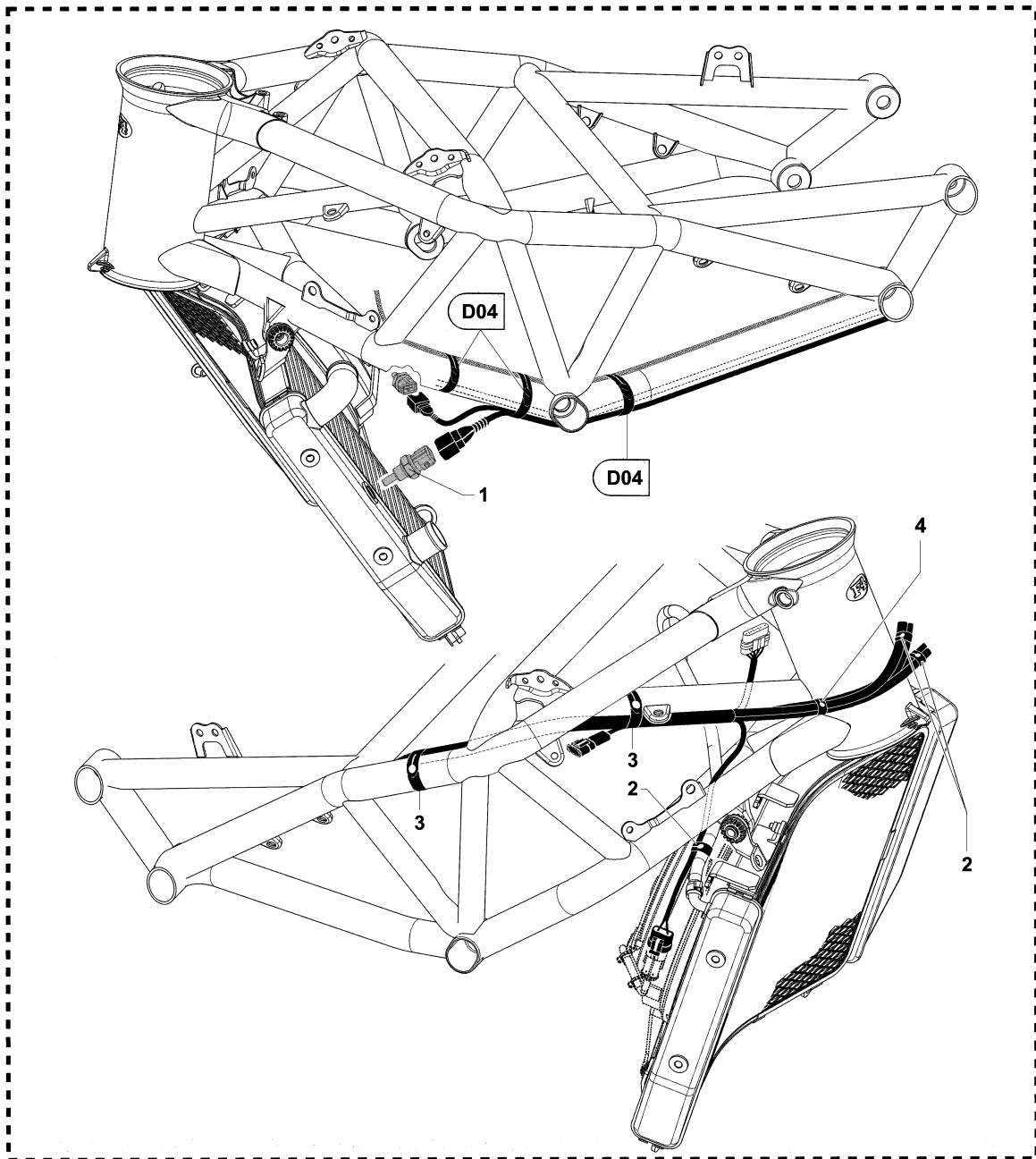

IMPIANTO ELETTRICOELECTRIC SYSTEM • INSTALLATION ÉLECTRIQUE
ELEKTRISCHE ANLAGE • INSTALACIÓN ELÉCTRICA

N.	Code	Q.ty	Note	BRUTALE ORO	BRUTALE S	► I FRAME I ►	► I ENGINE I ►
1	800088575	1		•	•		
2	800053724	3		•	•		
3	800092248	2		•	•		
4	800092247	1		•	•		



IMPIANTO ELETTRICO
ELECTRIC SYSTEM • INSTALLATION ÉLECTRIQUE
ELEKTRISCHE ANLAGE • INSTALACIÓN ELÉCTRICA

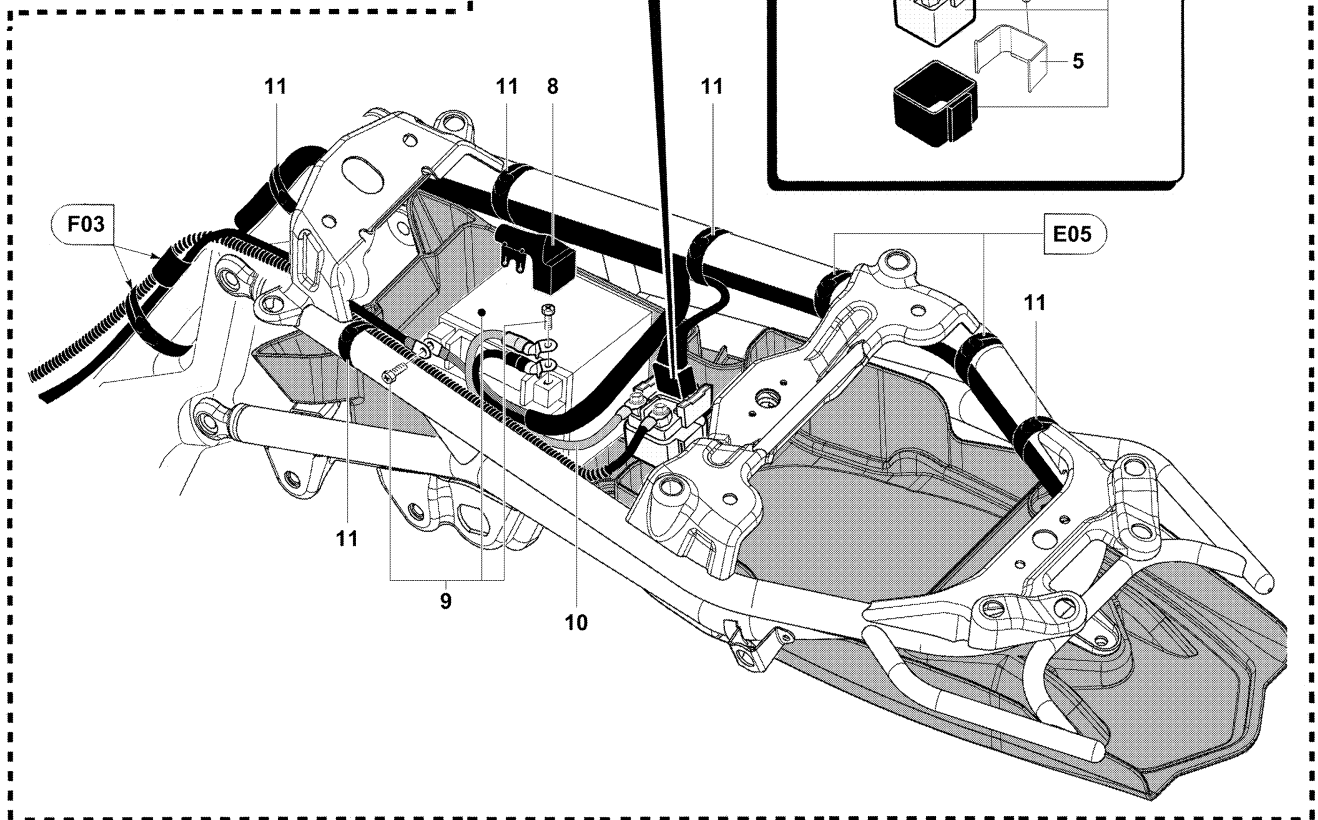
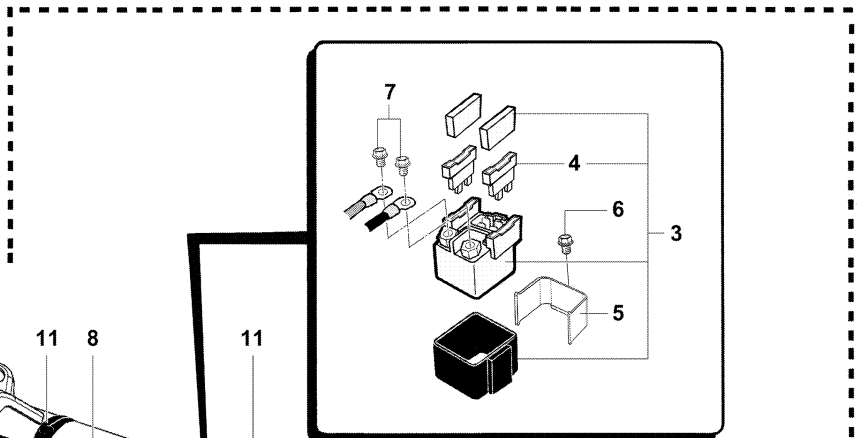
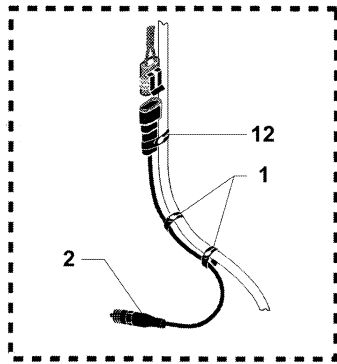
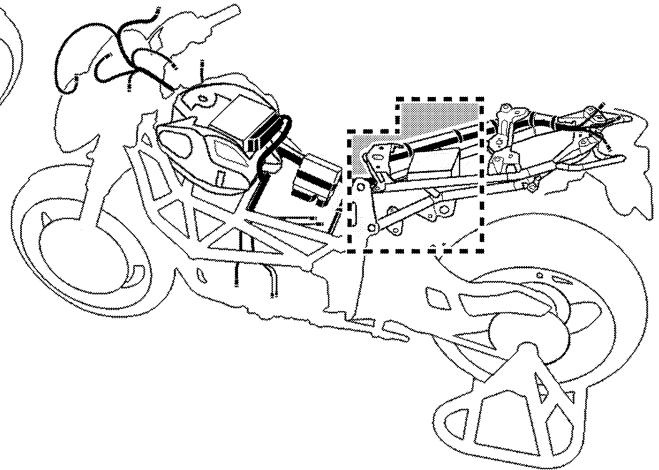
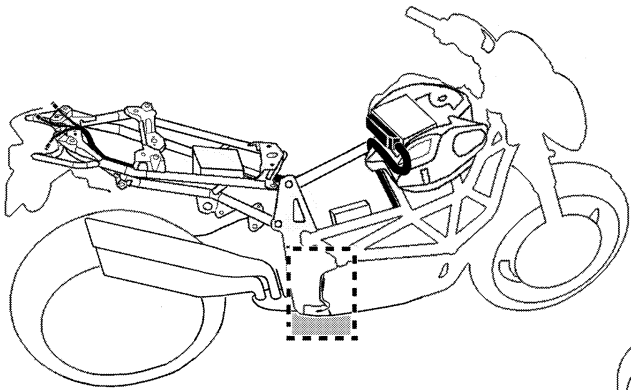

IMPIANTO ELETTRICO

 ELECTRIC SYSTEM • INSTALLATION ÉLECTRIQUE
 ELEKTRISCHE ANLAGE • INSTALACIÓN ELÉCTRICA

N.	Code	Q.ty	Note	BRUTALE ORO	BRUTALE S	► I FRAME I ►	► I ENGINE I ►
1	800053724	2		•	•		
2	800090213	1		•	•		
3	8000A5350	1		•	•		
4	800093018	2		•	•		
5	800099276	1		•	•		
6	8SA067545	1		•	•		
7	8SA067545	2		•	•		
8	800094890	1		•	•		
9	8000A3227	1	❶	•			
9	8000A3227	1	❶		•		► I 10760
9	8000A3227	1			•		10761 I ►
10	800099269	1		•	•		
11	800092247	5		•	•		
12	800053724	1		•	•		

- ❶ • Con questo particolare, ordinare anche:
- In addition to this part, you have to order the following:
 - Avec cette pièce, il est nécessaire de commander les pièces suivantes:
- Mit dieser Teil, du brauchst bestellen diese Teile:
- Con esta pieza, es necesario pedir las siguientes piezas:

N° 8000A3226 - Qt. 2.

F05

3



IMPIANTO ELETTRICO
ELECTRIC SYSTEM • INSTALLATION ÉLECTRIQUE
ELEKTRISCHE ANLAGE • INSTALACIÓN ELÉCTRICA

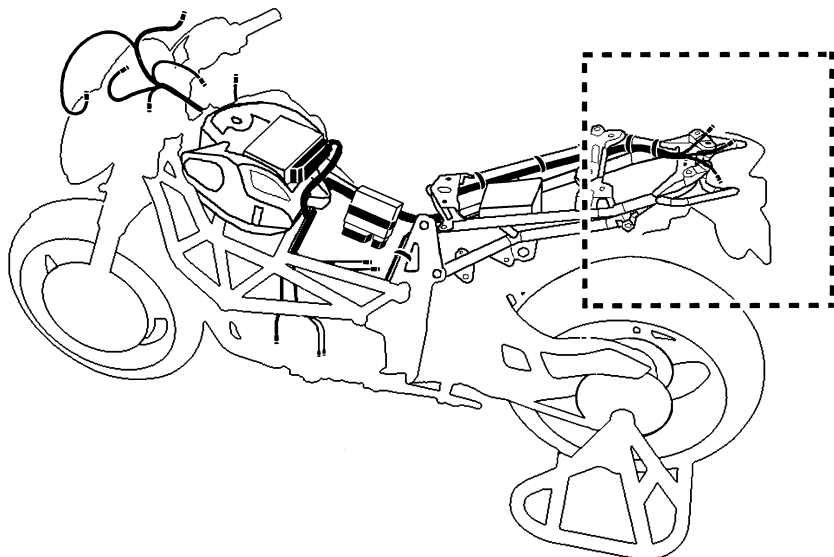
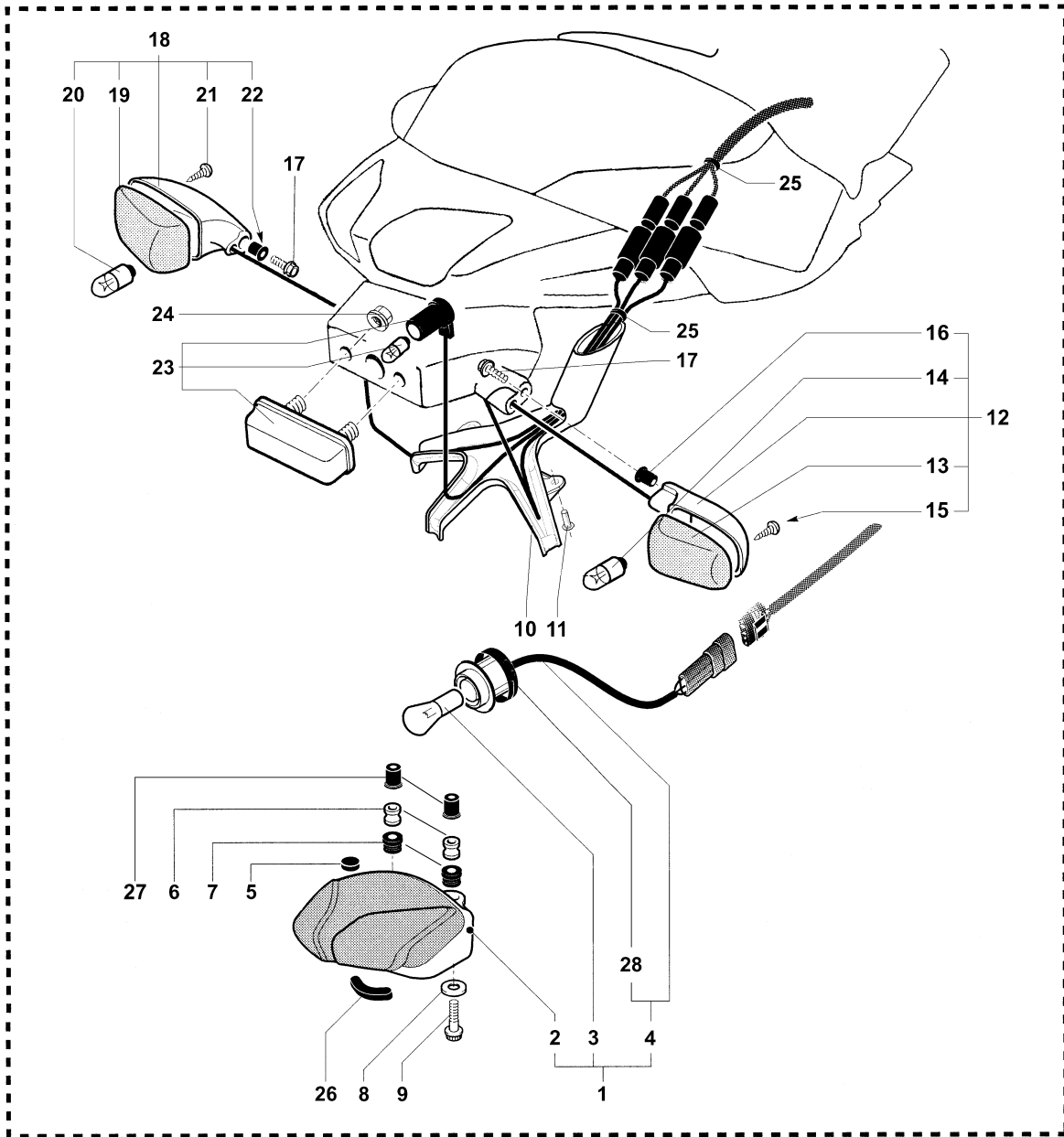

IMPIANTO ELETTRICO

ELECTRIC SYSTEM • INSTALLATION ÉLECTRIQUE
ELEKTRISCHE ANLAGE • INSTALACIÓN ELÉCTRICA



N.	Code	Q.ty	Note	BRUTALE ORO	BRUTALE S	► I FRAME I ►	► I ENGINE I ►
1	8B0090369	1		•	•		
2	800093335	1		•	•		
3	8A0018246	1		•	•		
4	8B0091696	1		•	•		
5	800095500	1		•	•		
6	800090415	2		•			
6	8000A1873	2			•		
7	800090239	2		•	•		
8	800056359	2		•	•		
9	8J0090425	2		•	•		
10	800099391	1		•	•		
11	8B0090901	2		•	•		
12	800090372	1		•	•		
13	800093336	1		•	•		
14	800036726	1		•	•		
15	800093416	1		•	•		
16	800048245	1		•	•		
17	800062728	2		•	•		
18	800090373	1		•	•		
19	800093337	1		•	•		
20	800036726	1		•	•		
21	800093416	1		•	•		
22	800048245	1		•	•		
23	800092185	1		•	•		
24	800056443	2		•	•		
25	800092668	2		•	•		
26	8000A2279	1		•	•		
27	800048245	2			•		
28	800092247	1		•	•		



IMPIANTO ELETTRICO
ELECTRIC SYSTEM • INSTALLATION ÉLECTRIQUE
ELEKTRISCHE ANLAGE • INSTALACIÓN ELÉCTRICA

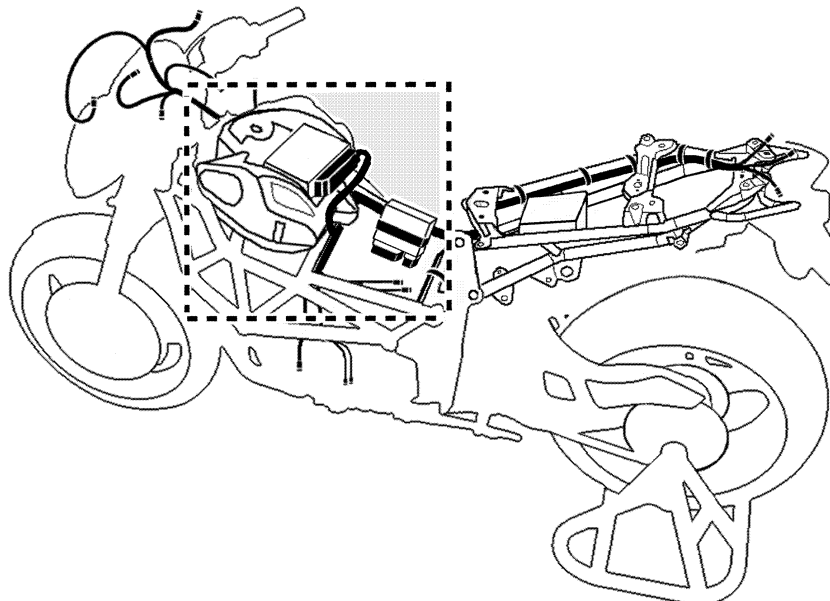
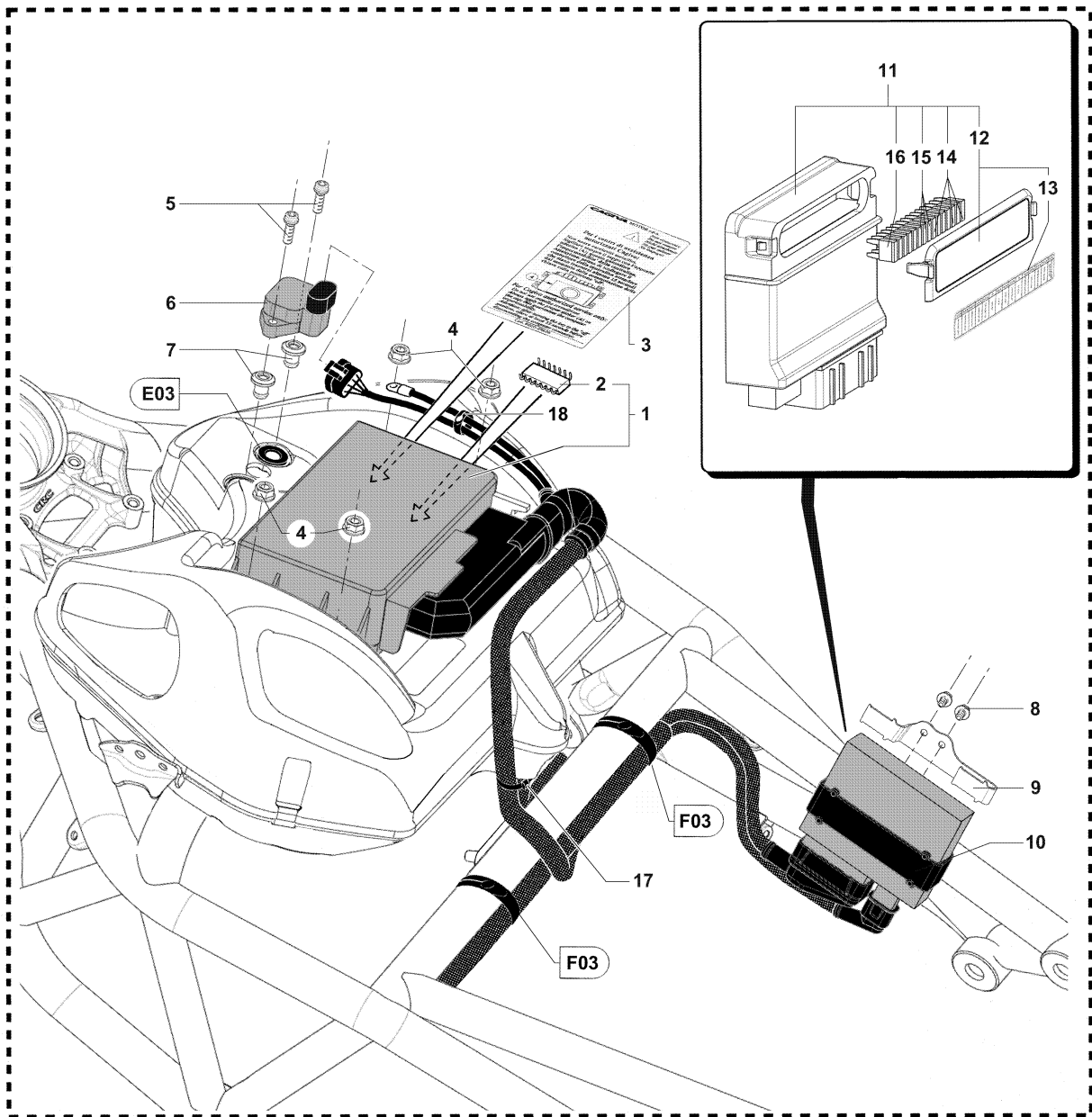

IMPIANTO ELETTRICO

 ELECTRIC SYSTEM • INSTALLATION ÉLECTRIQUE
 ELEKTRISCHE ANLAGE • INSTALACIÓN ELÉCTRICA



N.	Code	Q.ty	Note	BRUTALE ORO	BRUTALE S	► I FRAME I ►	► I ENGINE I ►
1	800099270	1		•			
1	8A0099270	1	F	•			
1	8C0099270	1	JPN	•			
1	800099270	1			•		► I 10760
1	8D0099270	1			•		10761 I ►
1	8A0099270	1	F		•		► I 10760
1	8E0099270	1	F		•		10761 I ►
1	8C0099270	1	JPN		•		► I 10760
1	8G0099270	1	JPN		•		10761 I ► ► I 11948
1	8J0099270	1	JPN		•		11949 I ►
2	800099272	1		•			
2	8A0099272	1	F	•			
2	8C0099272	1	JPN	•			
2	800099272	1			•		► I 10760
2	8D0099272	1			•		10761 I ►
2	8A0099272	1	F		•		► I 10760
2	8E0099272	1	F		•		10761 I ►
2	8C0099272	1	JPN		•		► I 10760
2	8G0099272	1	JPN		•		10761 I ► ► I 11948
2	8J0099272	1	JPN		•		11949 I ►
3	8A0089628	1		•	•		
4	800037901	4		•	•		
5	8D0090424	2		•	•		
6	800089398	1		•	•		
7	800090910	2		•	•		
8	8D0067997	2		•	•		
9	800098843	1		•	•		
10	800098298	1		•	•		
11	8000A9615	1		•			
11	8000A9615	1			•	► I 004321	
11	8000A9300	1			•	004322 I ►	
11	8000A9615	1	USA		•	► I 100421	
11	8000A9300	1	USA		•	100422 I ►	
12	8000A0923	1	1	•	•		
12	8000A9616	1	2	•	•		
13	8000A0924	1		•	•		
14	8C0099274	7		•	•		
15	8F0099274	5		•	•		
16	8D0099274	1		•	•		
17	8000A2781	1		•	•		
18	800092668	1		•	•		

- 1** Prima della sostituzione del part. N° 11 - Before the replacement of part No. 11 - Avant du remplacement du pièce N° 11 - Bevor Wechsel von Teil Nr. 11 - Antes de la sustitución de la pieza N° 11.
2 Dopo la sostituzione del part. N° 11 - After the replacement of part No. 11 - Suite au remplacement du pièce N° 11 - Nach Wechsel von Teil Nr. 11 - Después de la sustitución de la pieza N° 11.

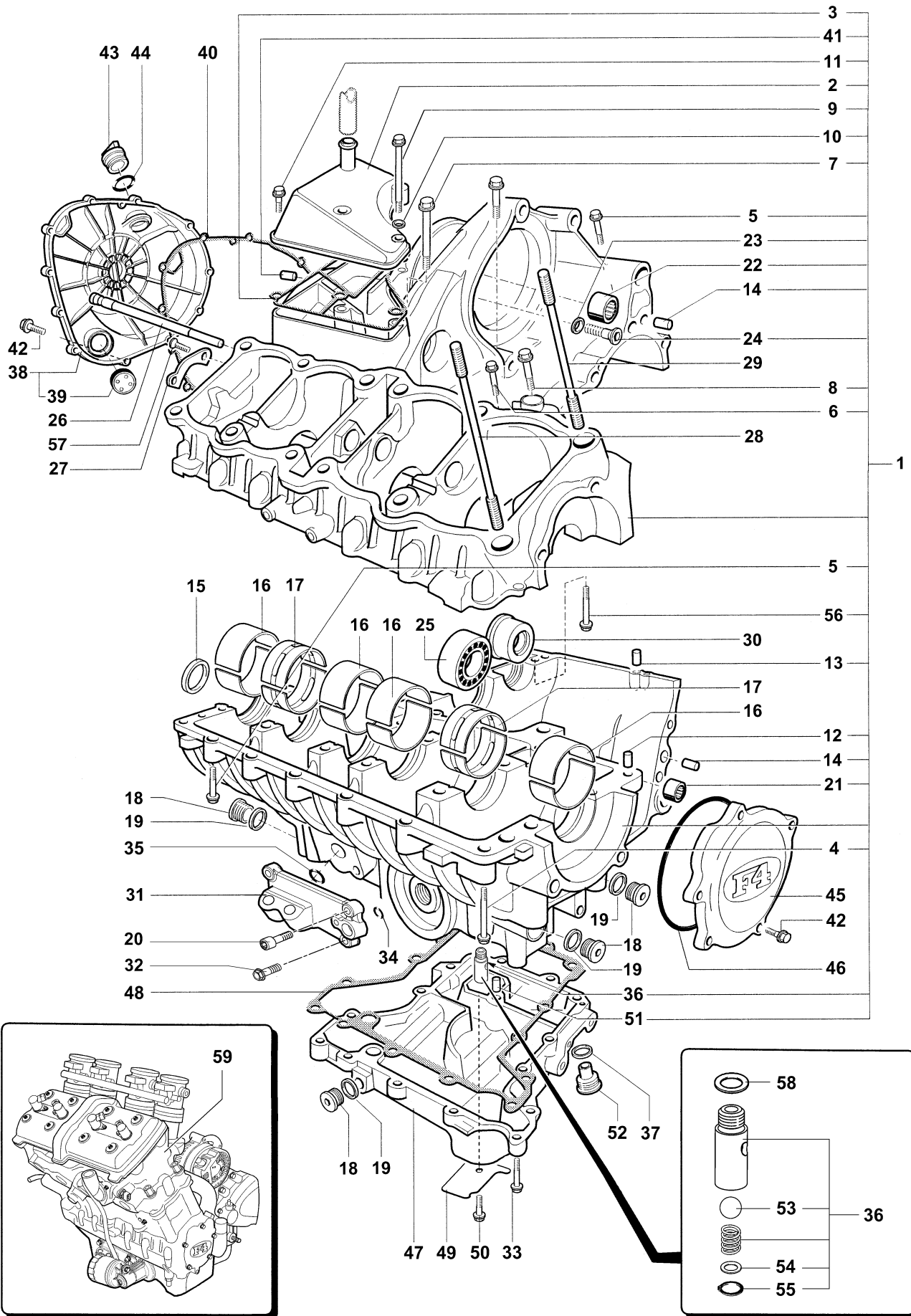

ASSIEME CARTER MOTORE

CRANKCASE ASSEMBLY • ENSEMBLE CARTER DU MOTEUR
BAUGRUPPE MOTORGEHÄUSE • CONJUNTO CÁRTER MOTOR



- 43
- 44
- 40
- 42
- 38
- 39
- 26
- 57
- 27

- 3
- 41
- 11
- 2
- 9
- 10
- 7

- 5
- 23
- 22
- 14
- 24
- 29

- 8
- 6
- 1

- 15
- 16
- 17
- 16
- 16
- 25
- 18
- 19
- 35
- 31
- 20
- 32
- 48

- 5
- 56
- 13
- 17
- 16
- 12
- 14
- 21
- 4
- 45
- 42
- 46

- 30
- 34
- 19
- 18
- 19
- 36
- 51
- 52
- 37
- 18
- 19
- 47
- 49
- 50
- 33

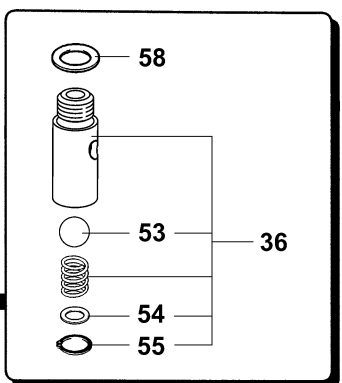
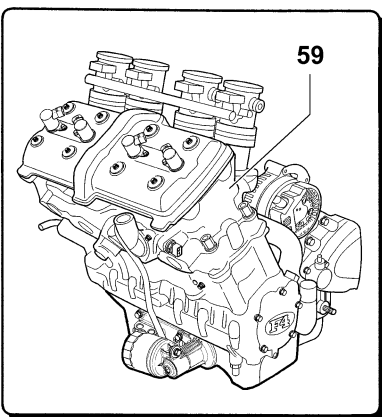

ASSIEME CARTER MOTORE

 CRANKCASE ASSEMBLY • ENSEMBLE CARTER DU MOTEUR
 BAUGRUPPE MOTORGEHÄUSE • CONJUNTO CÁRTER MOTOR

N.	Code	Q.ty	Note	BRUTALE ORO	BRUTALE S	► I FRAME I ►	► I ENGINE I ►
1	800098440	1		•			
1	800098440	1			•		► I 10760
1	8000A3448	1			•		10761 I ►
2	800099104	1		•	•		
3	800087792	1		•	•		
4	800098219	12		•	•		
5	8A0067545	12		•	•		
6	8B0067545	1		•	•		
7	800099476	1		•	•		
8	8A0091697	2		•	•		
9	8V0067545	1		•	•		
10	800064988	1		•	•		
11	800062729	4		•	•		
12	800007719	3		•	•		
13	8A0051549	1		•	•		
14	800086119	3		•	•		
15	800081412	1		•	•		
16	800081317	8	①	•	•		
16	8A0081317	8	②	•	•		
16	8B0081317	8	③	•	•		
17	800081316	4	①	•	•		
17	8A0081316	4	②	•	•		
17	8B0081316	4	③	•	•		
18	800089425	4		•	•		
19	800089426	4		•	•		
20	800098841	1		•	•		
21	800087300	1		•	•		
22	800081422	1		•	•		
23	800086737	1		•	•		
24	800028327	1		•	•		
25	800098404	1		•			
25	800098404	1			•		06446 I ► ► I 09191 10410 I ► ► I 10967
25	800098405	1			•		09192 I ► ► I 10409 10968 I ►
26	800089440	1		•	•		
27	800081413	1		•	•		
28	800081418	6		•	•		
29	800081419	6		•	•		
30	800081424	1		•			
30	800081424	1			•		06446 I ► ► I 09191 10410 I ► ► I 10967
30	8000A1087	1			•		09192 I ► ► I 10409 10968 I ►
31	80A098837	1		•	•		
32	800062729	3		•	•		
33	800062730	15		•	•		
34	8A0031106	1		•	•		
35	800023116	2		•	•		

- ① Semicuscinetto rosso • Red half bearing • Demi-coussinet rouge • Halblager rot • Semicojinete rojo
 ② Semicuscinetto blu • Blue half bearing • Demi-coussinet bleu • Halblager blau • Semicojinete azul
 ③ Semicuscinetto giallo • Yellow half bearing • Demi-coussinet jaune • Halblager gelb • Semicojinete amarillo





ASSIEME CARTER MOTORE

CRANKCASE ASSEMBLY • ENSEMBLE CARTER DU MOTEUR
 BAUGRUPPE MOTORGEHÄUSE • CONJUNTO CÁRTER MOTOR

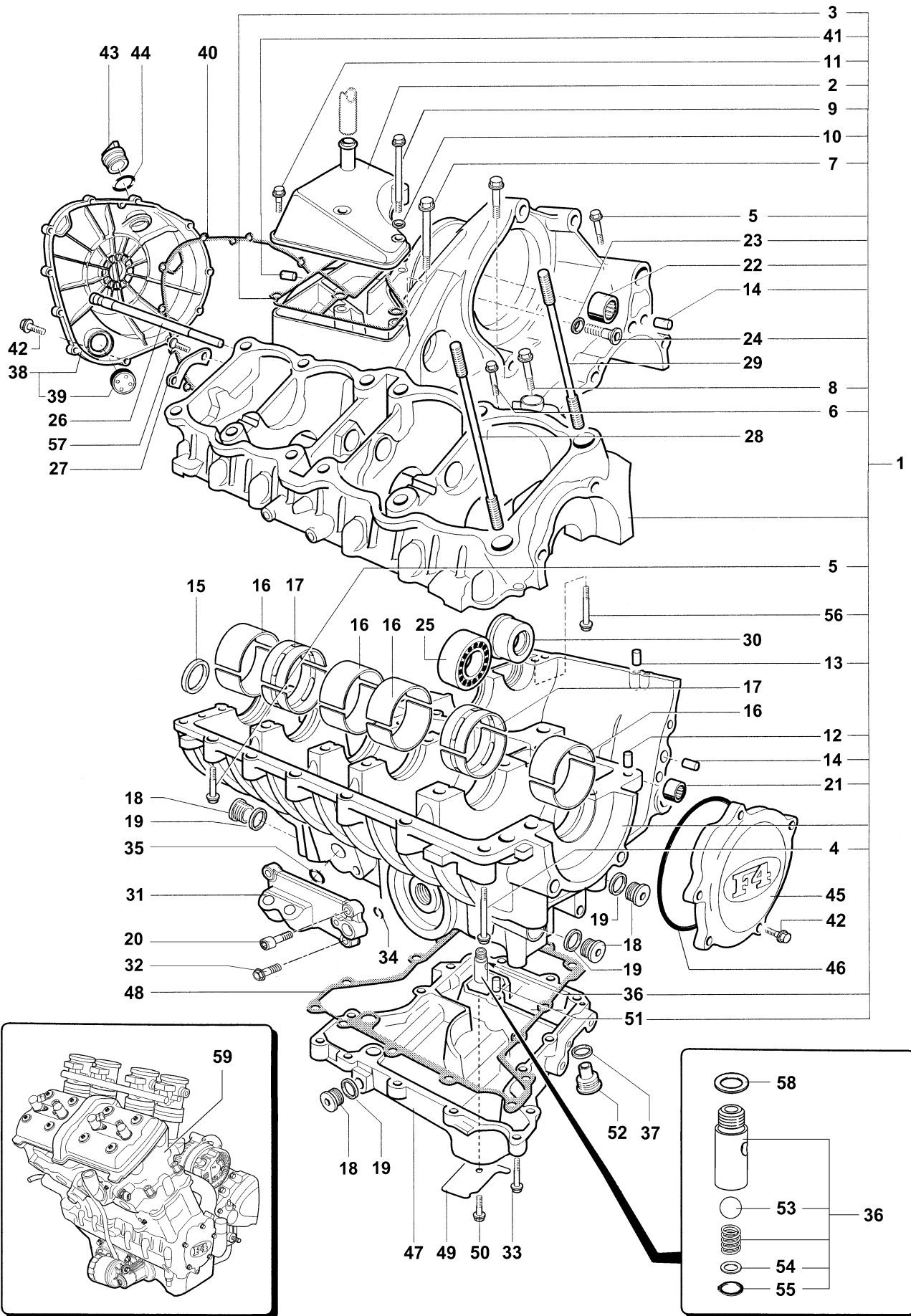

ASSIEME CARTER MOTORE

 CRANKCASE ASSEMBLY • ENSEMBLE CARTER DU MOTEUR
 BAUGRUPPE MOTORGEHÄUSE • CONJUNTO CÁRTER MOTOR



N.	Code	Q.ty	Note	BRUTALE ORO	BRUTALE S	► I FRAME I ►	► I ENGINE I ►
36	800081403	1		•	•		
37	62N015682	1		•	•		
38	800099105	1		•	•		
39	800073529	1		•	•		
40	800080691	1		•	•		
41	8C0019590	2		•	•		
42	800062728	16		•	•		
43	800092473	1		•	•		
44	8A0023120	1		•	•		
45	80A086728	1		•	•		
46	800094626	1		•	•		
47	80A092469	1		•	•		
48	800087786	1		•	•		
49	800089422	1		•	•		
50	800062725	1		•	•		
51	800007719	2		•	•		
52	800096747	1		•	•		
53	6BN021513	1		•	•		
54	8000A2934	1		•	•		
55	66N021251	1		•	•		
56	60N402562	1		•			
56	60N402562	1			•		► I 10760
56	8A0091697	1			•		10761 I ►
57	800060577	2		•	•		
58	800047763	1		•	•		
59	800091905	1		•			
59	800091905	1			•		► I 10760
59	8000A3445	1			•		10761 I ►



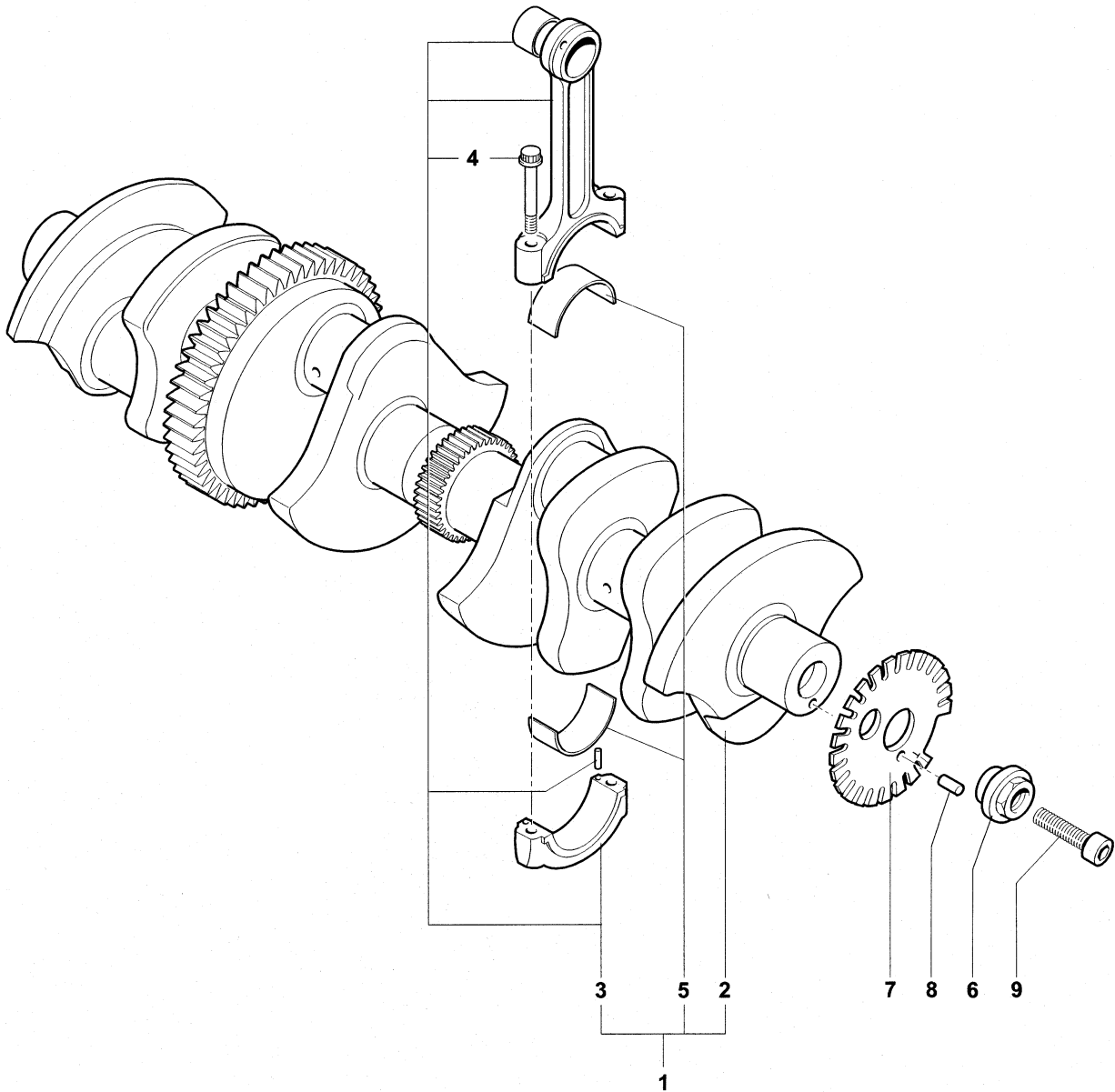

ASSIEME ALBERO MOTORE

ENGINE CRANKCASE ASSEMBLY • ENSEMBLE VILEBREQUIN
BAUGRUPPE KURBELWELLE • CONJUNTO CIGÜEÑAL



ASSIEME ALBERO MOTORE

 ENGINE CRANKCASE ASSEMBLY • ENSEMBLE VILEBREQUIN
 BAUGRUPPE KURBELWELLE • CONJUNTO CIGÜEÑAL

N.	Code	Q.ty	Note	BRUTALE ORO	BRUTALE S	► I FRAME I ►	► I ENGINE I ►
1	800091897	1		•			
1	800091897	1			•		► I 10760
1	8000A3985	1			•		10761 I ►
2	800091898	1		•	•		
3	8000A5238	4		•			
3	8000A5238	4			•		► I 10760
3	8000A5236	4			•		10761 I ►
4	8000A5237	8		•			
4	8000A5237	8			•		► I 10760
4	8000A5235	8			•		10761 I ►
5	800081315	8	①	•	•		
5	8A0081315	8	②	•	•		
5	8B0081315	8	③	•	•		
6	800086727	1		•	•		
7	800086726	1		•	•		
8	800019971	1		•	•		
9	60N102558	1		•	•		

- ① Semicuscinetto rosso • Red half bearing • Demi-coussinet rouge • Halblager rot • Semicojinete rojo
 ② Semicuscinetto blu • Blue half bearing • Demi-coussinet bleu • Halblager blau • Semicojinete azul
 ③ Semicuscinetto giallo • Yellow half bearing • Demi-coussinet jaune • Halblager gelb • Semicojinete amarillo



ASSIEME CILINDRI E PISTONE

DRIVING SHAFT ASSEMBLY • ENSEMBLE CYLINDRES ET PISTON

BAUGRUPPE ZYLINDER UND KOLBEN • CONJUNTO CILINDROS Y PISTONES

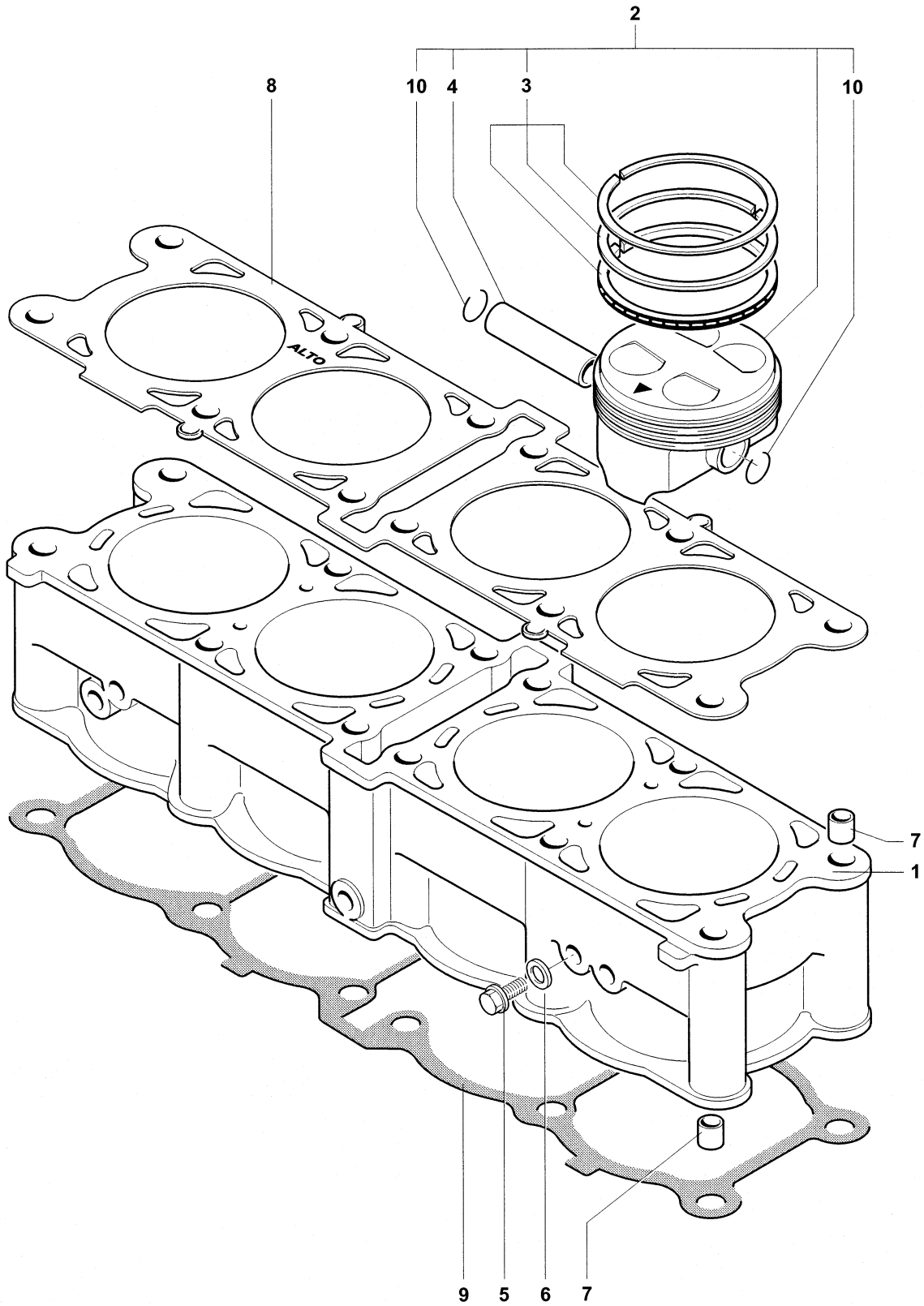

ASSIEME CILINDRI E PISTONE

DRIVING SHAFT ASSEMBLY • ENSEMBLE CYLINDRES ET PISTON

BAUGRUPPE ZYLINDER UND KOLBEN • CONJUNTO CILINDROS Y PISTONES



N.	Code	Q.ty	Note	BRUTALE ORO	BRUTALE S	►I FRAME I►	►I ENGINE I►
1	80A098020	1		•	•		
2	800098021	4		•	•		
3	800098023	4		•	•		
4	800098027	4		•	•		
5	800081536	2		•	•		
6	800064988	2		•	•		
7	800081535	4		•	•		
8	800098679	1	≠ 1.45	•	•		
8	8A0098679	1	≠ 1.30	•	•		
8	8B0098679	1	≠ 1.20	•	•		
9	800087771	1		•	•		
10	800098028	8		•	•		



ASSIEME TESTATA
CYLINDER HEAD ASSEMBLY • ENSEMBLE CULASSE
BAUGRUPPE ZYLINDERKOPF • CONJUNTO CULATA

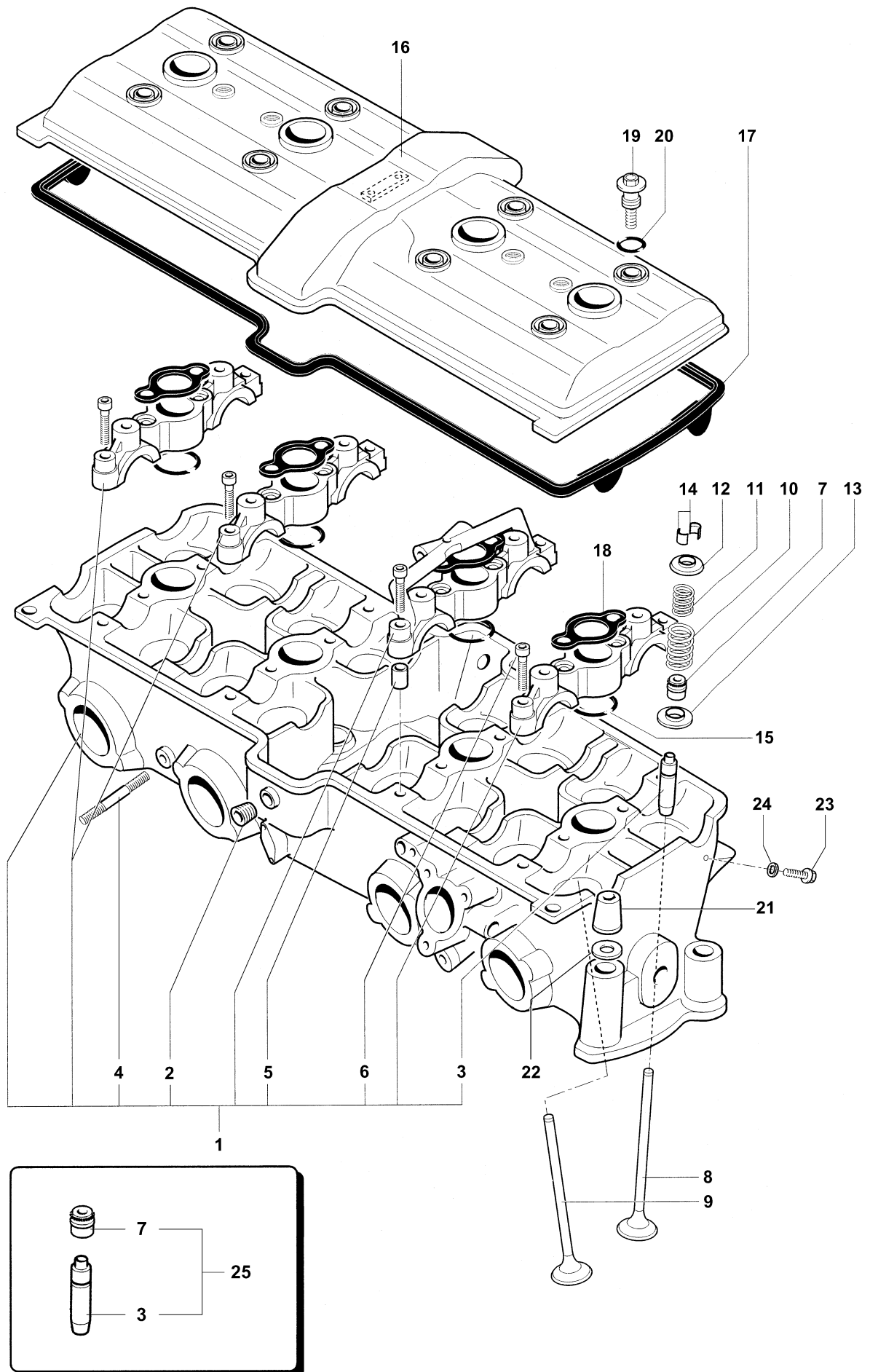

ASSIEME TESTATA

 CYLINDER HEAD ASSEMBLY • ENSEMBLE CULASSE
 BAUGRUPPE ZYLINDERKOPF • CONJUNTO CULATA

N.	Code	Q.ty	Note	BRUTALE ORO	BRUTALE S	► I FRAME I ►	► I ENGINE I ►
1	800097250	1		•			
1	800097250	1			•		► I 10760
1	8000A3980	1			•		10761 I ►
2	800069769	7		•	•		
3	8A0081228	16	①	•	•		
3	8B0081228	16	②	•	•		
4	800091064	2		•	•		
5	800051549	8		•	•		
6	800085071	16		•	•		
7	800065814	16		•	•		
8	800097918	8		•	•		
9	800097919	8		•	•		
10	800098670	16		•	•		
11	800098671	16		•	•		
12	800098761	16		•			
12	800098761	16			•		► I 10760
12	8000A3732	16			•		10761 I ►
13	800098681	16		•			
13	800098681	16			•		► I 10760
13	8000A3733	16			•		10761 I ►
14	800092433	32		•	•		
15	800087752	4		•	•		
16	8000A0105	1		•	•		
17	800087756	1		•	•		
18	800087755	4		•	•		
19	800087779	8		•	•		
20	8A0025082	8		•	•		
21	800081547	12		•	•		
22	800069156	12		•	•		
23	8D0067997	4		•			
23	8D0067997	4			•		► I 09249
24	800036137	4		•			
24	800036137	4			•		► I 09249
25	8000A2306	16	①	•	•		
25	8A00A2306	16	②	•	•		

① Maggiorata 0.025 mm • Oversized 0.025 mm • Surdimensionnée 0.025 mm • Übermaß 0.025 mm • Extra grande 0.025 mm
 ② Maggiorata 0.05 mm • Oversized 0.05 mm • Surdimensionnée 0.05 mm • Übermaß 0.05 mm • Extra grande 0.05 mm



DISTRIBUZIONE
TIMING SYSTEM • DISTRIBUTION
VENTILSTEUERUNG • DISTRIBUCIÓN

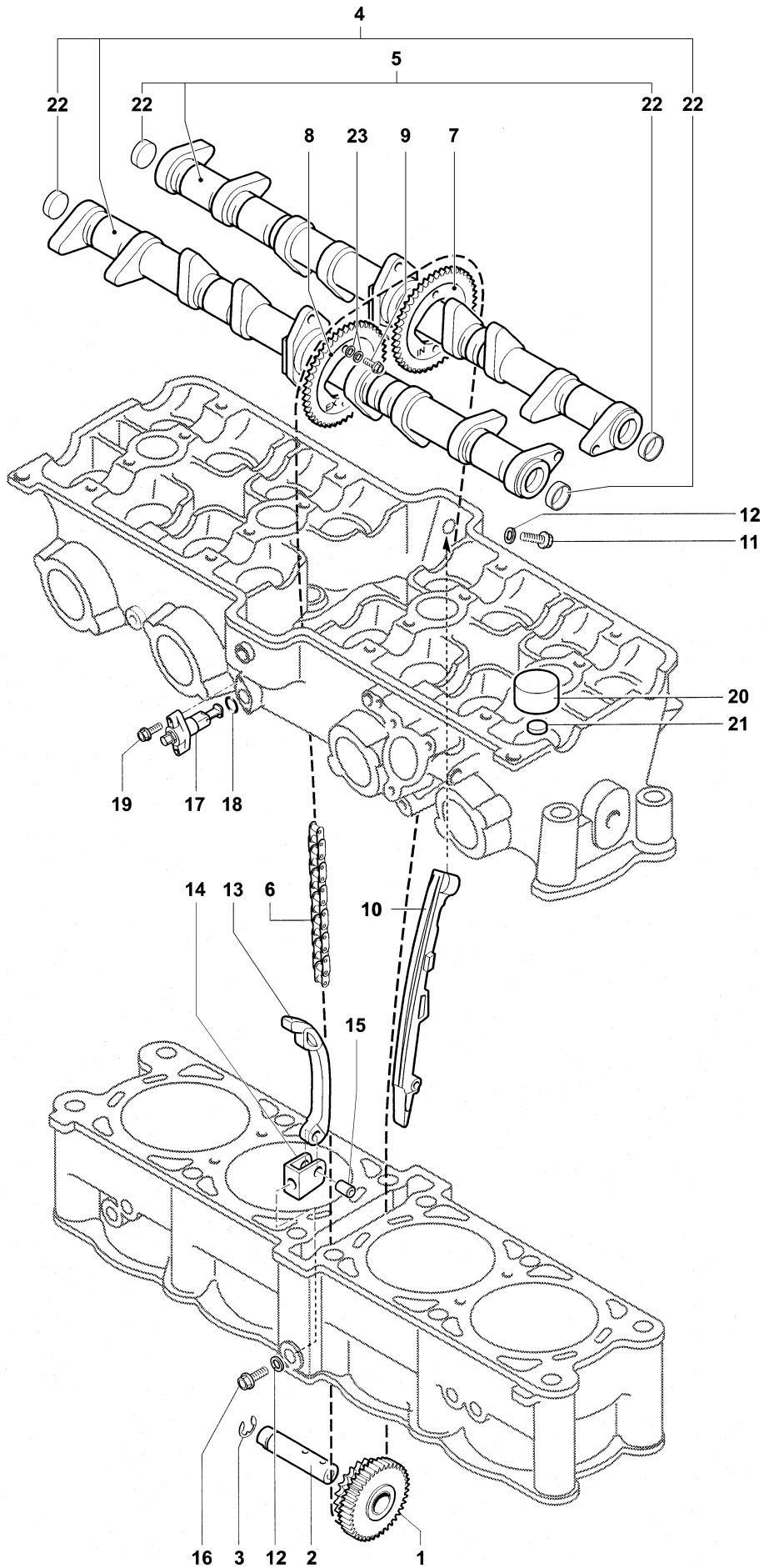



N.	Code	Q.ty	Note	BRUTALE ORO	BRUTALE S	► I FRAME I ◄	► I ENGINE I ◄
1	800089445	1		•	•		
2	800081261	1		•	•		
3	66N021313	1		•	•		
4	800087782	1		•	•		
5	800099068	1		•	•		
6	8000A0120	1	❶	•	•		
6	800096598	1	❷	•	•		
7	800098769	1		•			
7	800098769	1			•		► I 10760
7	8000A3983	1			•		10761 I ►
8	800097938	1		•			
8	800097938	1			•		► I 10760
8	8000A3984	1			•		10761 I ►
9	800062726	4		•			
9	800062726	4			•		► I 10760
9	8C0085071	4			•		10761 I ►
10	800081552	1		•	•		
11	800062728	1		•	•		
12	800064988	2		•	•		
13	800086735	1		•	•		
14	800087784	1		•	•		
15	800087785	1		•	•		
16	800062727	1		•	•		
17	800091895	1		•	•		
18	800018422	1		•	•		
19	800062729	2		•	•		
20	8000A1839	16		•	•		
21	800084182	16	≠ 1.60	•	•		
21	8A0084182	16	≠ 1.65	•	•		
21	8B0084182	16	≠ 1.70	•	•		
21	8C0084182	16	≠ 1.75	•	•		
21	8D0084182	16	≠ 1.80	•	•		
21	8E0084182	16	≠ 1.85	•	•		
21	8F0084182	16	≠ 1.90	•	•		
21	8G0084182	16	≠ 1.95	•	•		
21	8H0084182	16	≠ 2.00	•	•		
21	8J0084182	16	≠ 2.05	•	•		
21	8K0084182	16	≠ 2.10	•	•		
21	8L0084182	16	≠ 2.15	•	•		
21	8M0084182	16	≠ 2.20	•	•		
21	8N0084182	16	≠ 2.25	•	•		
21	8P0084182	16	≠ 2.30	•	•		
21	8R0084182	16	≠ 2.35	•	•		
21	8S0084182	16	≠ 2.40	•	•		
21	8T0084182	16	≠ 2.45	•	•		
21	8U0084182	16	≠ 2.50	•	•		
21	8V0084182	16	≠ 2.55	•	•		
21	8W0084182	16	≠ 2.60	•	•		
22	8B0057196	4		•	•		
23	8000A3486	4			•		10761 I ►

- ❶ Catena di distribuzione chiusa - Timing chain closed - Chaîne de distribution fermée - Ventilsteuerkette geschlossen - Cadena de distribución cerrada
 ❷ Catena di distribuzione aperta - Timing chain open - Chaîne de distribution ouverte - Ventilsteuerkette offen - Cadena de distribución abierta



LUBRIFICAZIONE
LUBRICATION SYSTEM • GRAISSAGE
SCHMIERSYSTEM • LUBRIFICACIÓN

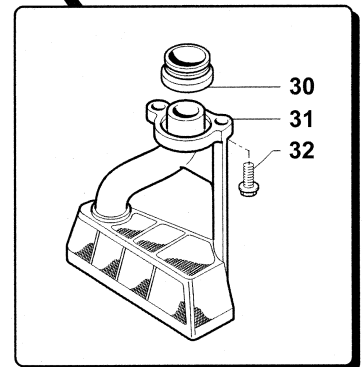
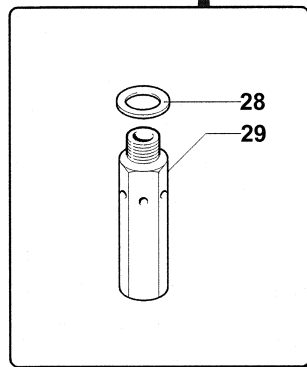
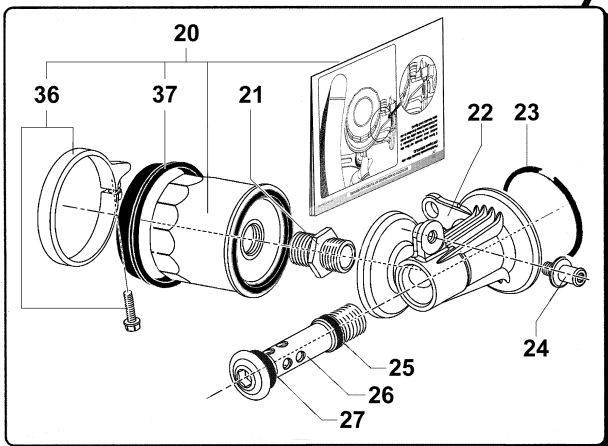
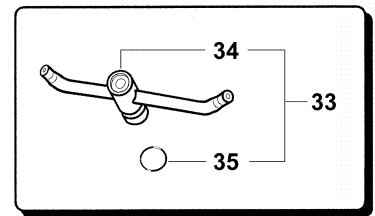
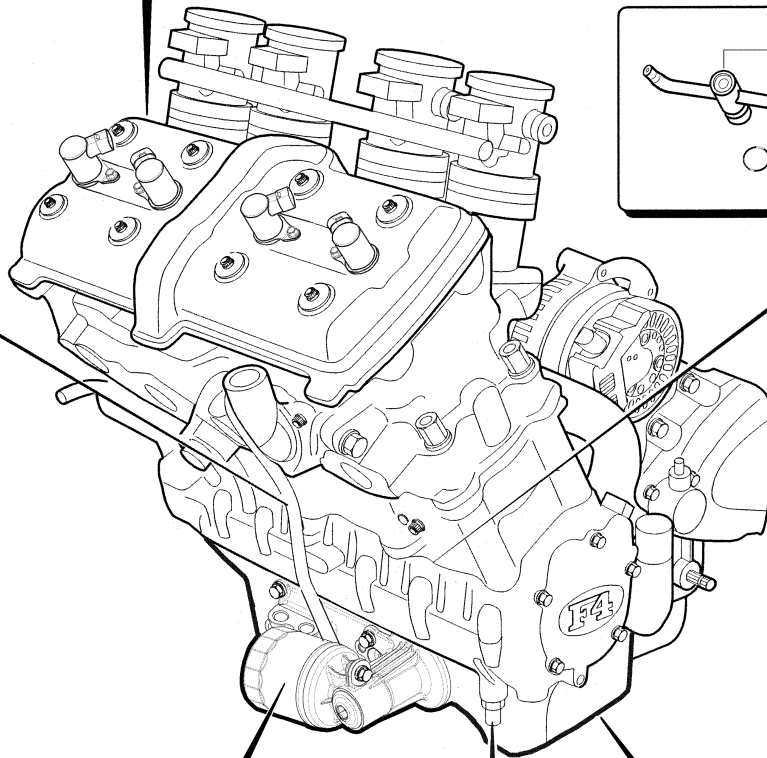
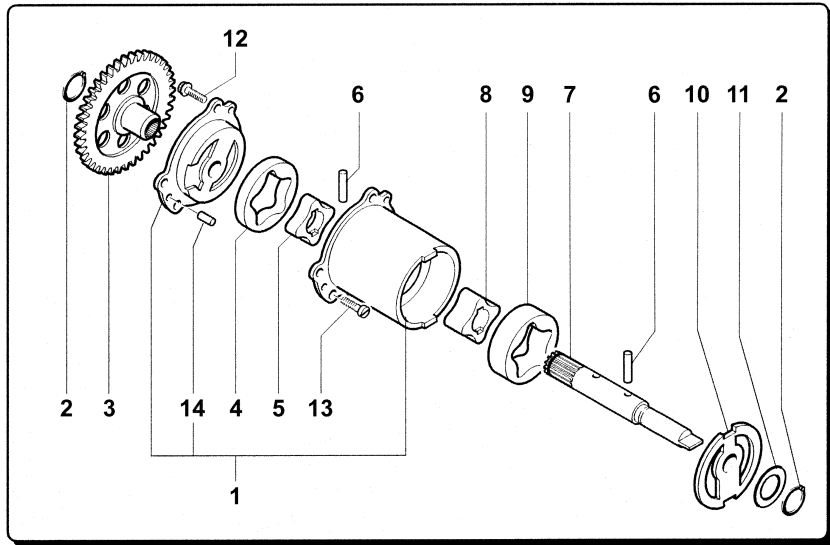
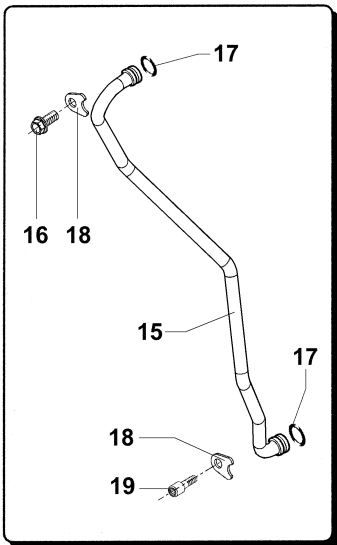



N.	Code	Q.ty	Note	BRUTALE ORO	BRUTALE S	► I FRAME I ►	► I ENGINE I ►
1	800086201	1		•	•		
2	66N021203	2		•	•		
3	800081357	1		•	•		
4	800081364	1		•	•		
5	800081365	1		•	•		
6	800019590	2		•	•		
7	800080701	1		•	•		
8	800081363	1		•	•		
9	800081362	1		•	•		
10	800081443	1		•	•		
11	8D0009408	1		•	•		
12	800062728	3		•	•		
13	800035408	1		•	•		
14	800038520	2		•	•		
15	800099127	1		•	•		
16	800062726	1		•	•		
17	800023108	2		•	•		
18	800095505	2		•	•		
19	8A0098841	1		•	•		
20	8000A3702	1		•	•		
21	800081409	1		•	•		
22	80A098835	1		•	•		
23	800099126	1		•	•		
24	800098839	1		•	•		
25	800031175	1		•	•		
26	800098840	1		•	•		
27	800029074	1		•	•		
28	800047763	1		•	•		
29	800086132	1		•	•		
30	800080695	1		•	•		
31	800080689	1		•	•		
32	800062728	2		•	•		
33	800091915	2		•	•		
34	800091914	2		•	•		
35	800023106	2		•	•		
36	8000A1488	1		•	•		
37	8000A3281	1		•	•		



POMPA ACQUA
WATER PUMP • POMPE À EAU
WASSERPUMPE • BOMBA AGUA

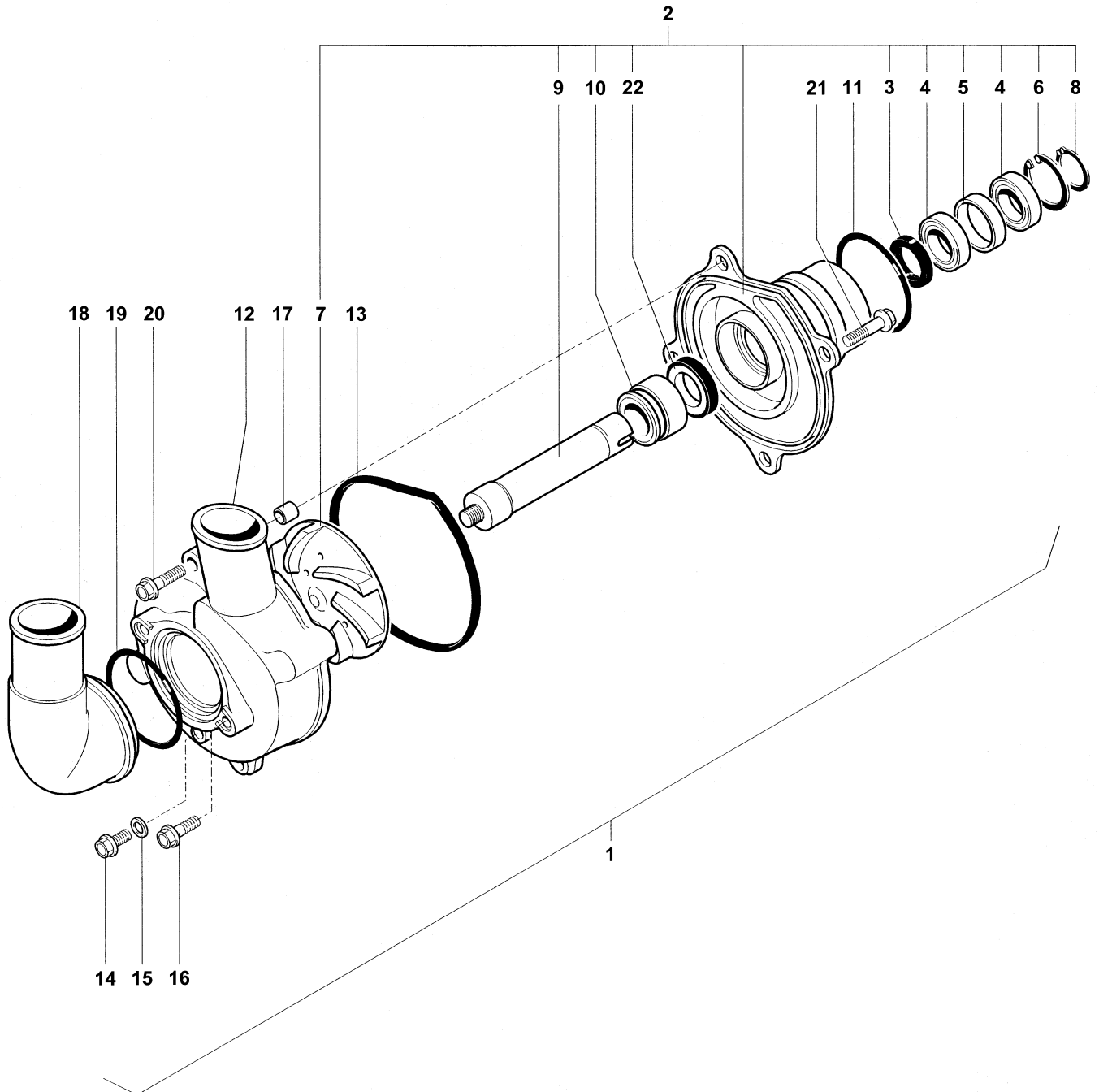



N.	Code	Q.ty	Note	BRUTALE ORO	BRUTALE S	► I FRAME I ►	► I ENGINE I ►
1	800099110	1		•	•		
2	800099111	1		•	•		
3	8A0028855	1		•	•		
4	800034317	2		•	•		
5	800081239	1		•	•		
6	66N221262	1		•	•		
7	800081538	1		•	•		
8	66N221202	1		•	•		
9	800081539	1		•	•		
10	800081236	1		•	•		
11	800035809	1		•	•		
12	80A089412	1		•	•		
13	800086702	1		•	•		
14	800081536	1		•	•		
15	800064988	1		•	•		
16	800062727	2		•	•		
17	800051549	2		•	•		
18	80A089405	1		•	•		
19	800017679	1		•	•		
20	8A0067545	2		•	•		
21	800062727	2		•	•		
22	800081237	1		•	•		



IMPIANTO DI RAFFREDDAMENTO
COOLING SYSTEM • CIRCUIT DE REFRROIDISSEMENT
KÜHLSYSTEM • INSTALACIÓN DE REFRIGERACIÓN

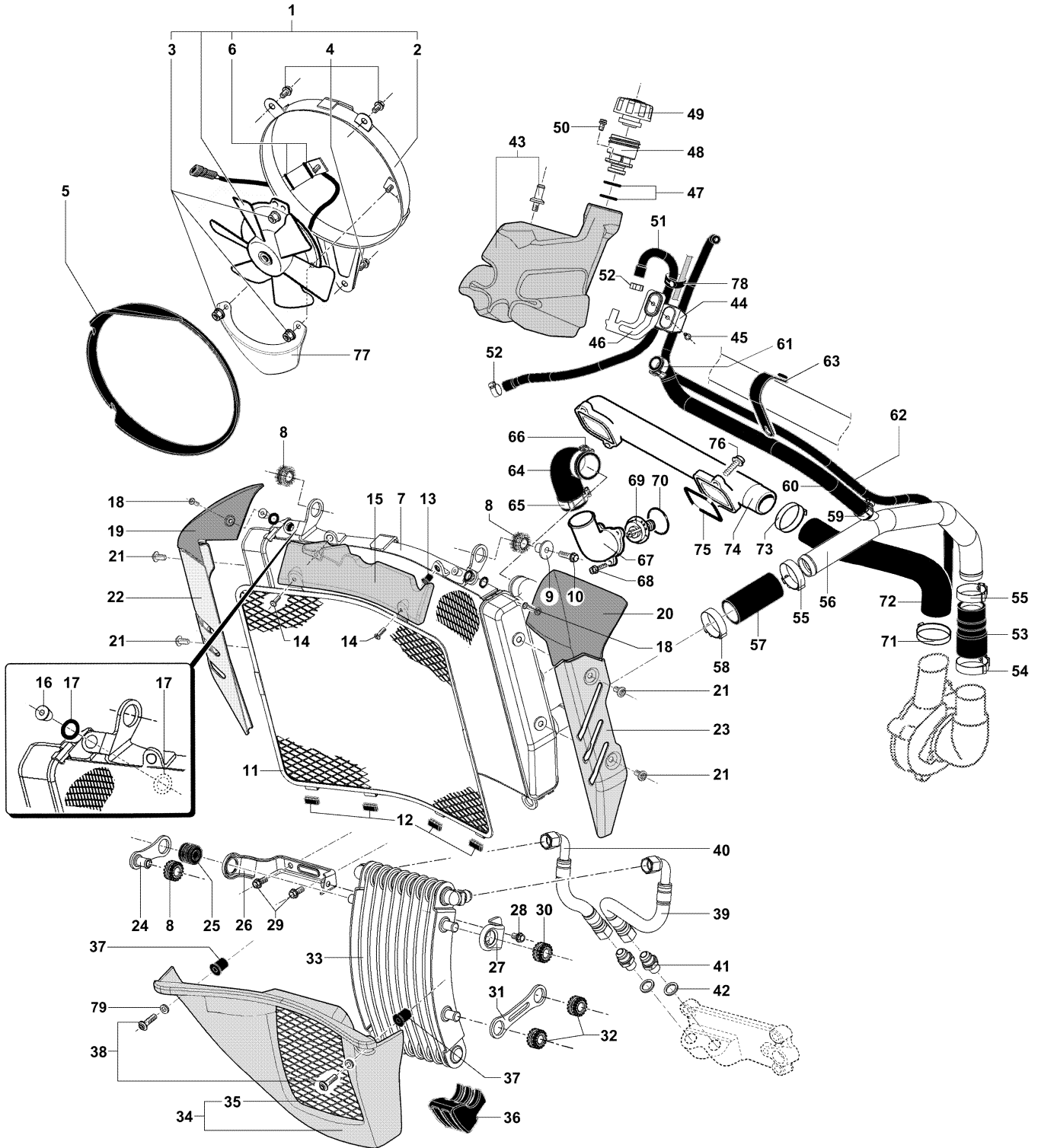

IMPIANTO DI RAFFREDDAMENTO

 COOLING SYSTEM • CIRCUIT DE REFROIDISSEMENT
 KÜHLSYSTEM • INSTALACIÓN DE REFRIGERACIÓN

N.	Code	Q.ty	Note	BRUTALE ORO	BRUTALE S	► I FRAME I ◀	► I ENGINE I ◀
1	800099247	1		•	•		
2	800099245	1		•	•		
3	800042278	3		•	•		
4	800062725	3		•	•		
5	800099125	1		•	•		
6	800056783	2		•	•		
7	800099243	1		•	•		
8	800062651	3		•	•		
9	800062652	1		•	•		
10	800062728	1		•	•		
11	800098716	1		•	•		
12	800099249	4		•	•		
13	800091022	2		•	•		
14	8A0090901	2		•	•		
15	8000A1409	1		•	•		
16	800091022	2		•	•		
17	800099278	4		•	•		
18	8A0090901	2		•	•		
19	800098694	1		•	•		
20	800098695	1		•	•		
21	8A0089786	4		•	•		
22	800098336	1		•	•		
23	800098335	1		•	•		
24	800098323	1		•	•		
25	800098834	1		•	•		
26	80A098700	1		•	•		
27	80A098699	1		•	•		
28	800062725	1		•	•		
29	800062726	2		•	•		
30	800062651	1		•	•		
31	800098698	1		•	•		
32	800062651	2		•	•		
33	800097905	1		•	•		
34	800099294	1		•	•		
34	800099432	1		•	•		
35	800099293	1		•	•		
36	800099322	1		•	•		
37	800048245	2		•	•		
38	800089786	2		•	•		
39	800099159	1		•	•		
40	800099160	1		•	•		
41	800098842	2		•	•		
42	800088526	2		•	•		
43	800098943	1		•	•		
44	800097884	1		•	•		
45	8A0066778	1		•	•		
46	800099453	1		•	•		
47	800090945	2		•	•		
48	8A0090944	1		•	•		
49	800091707	1		•	•		
50	8C0090424	2		•	•		
51	800090245	1		•	•		
52	800092256	2		•	•		
53	800090244	1		•	•		
54	8U0092249	1		•	•		





IMPIANTO DI RAFFREDDAMENTO
COOLING SYSTEM • CIRCUIT DE REFRROIDISSEMENT
KÜHLSYSTEM • INSTALACIÓN DE REFRIGERACIÓN

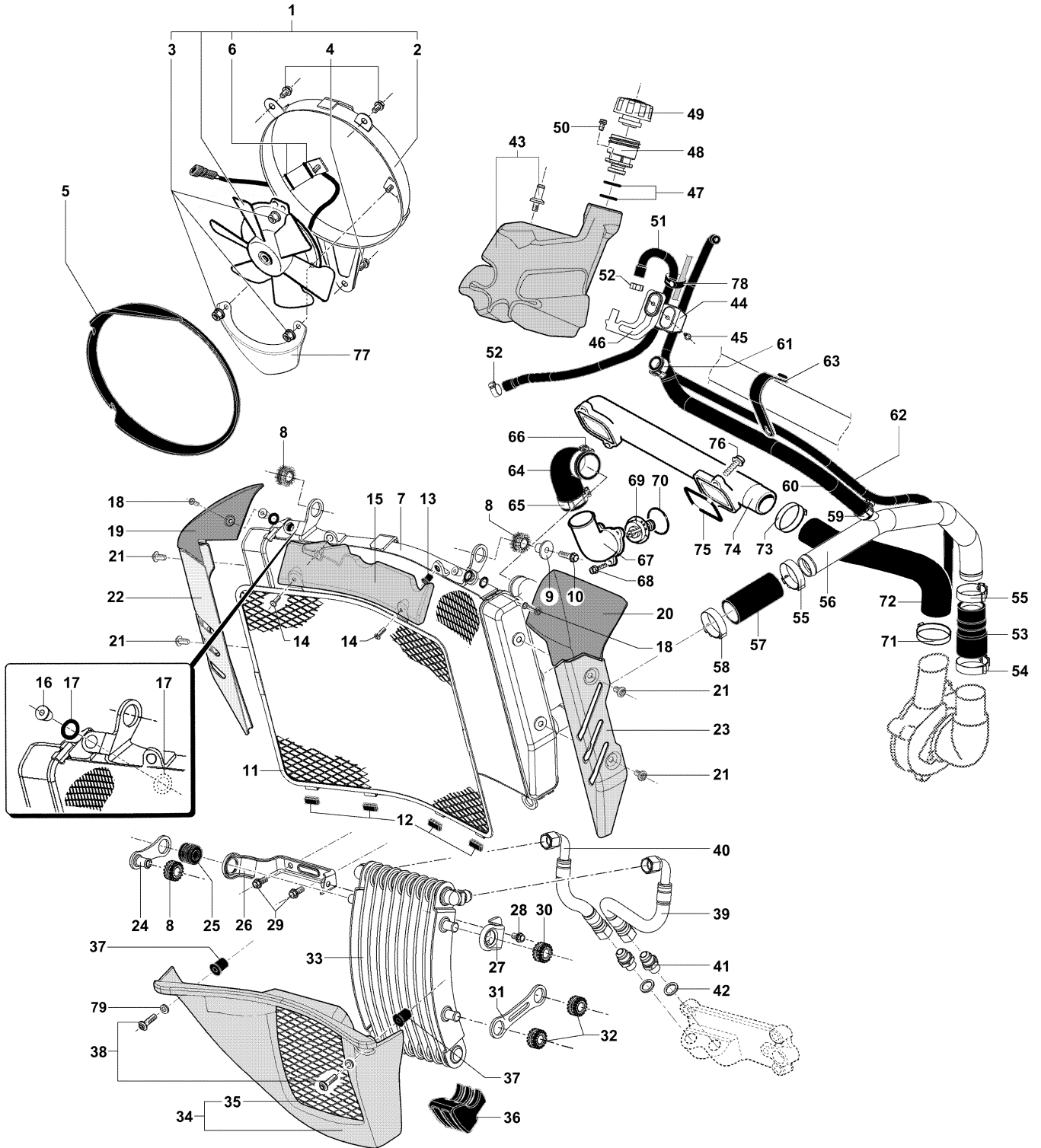

IMPIANTO DI RAFFREDDAMENTO

COOLING SYSTEM • CIRCUIT DE REFROIDISSEMENT
KÜHLSYSTEM • INSTALACIÓN DE REFRIGERACIÓN



N.	Code	Q.ty	Note	BRUTALE ORO	BRUTALE S	► I FRAME I ►	► I ENGINE I ►
55	8G0092249	2		•	•		
56	800099250	1		•	•		
57	8A0097109	1		•	•		
58	8V0092249	1		•	•		
59	8E0092249	1		•	•		
60	8A0094186	1		•	•		
61	8Q0092249	1		•	•		
62	8M0066179	1		•	•		
63	800092248	1		•	•		
64	800089794	1		•	•		
65	8C0092249	1		•	•		
66	8G0092249	1		•	•		
67	80A087761	1		•	•		
68	800062728	3		•	•		
69	800081283	1		•	•		
70	800069413	1		•	•		
71	8F0092249	1		•	•		
72	800081280	1		•	•		
73	8F0092249	1		•	•		
74	80A091923	1		•	•		
75	800017679	2		•	•		
76	800062728	4		•	•		
77	800098334	1		•	•		
78	800053724	1		•	•		
79	800089751	2		•	•		





ASSIEME FRIZIONE
CLUTCH ASSEMBLY • ENSEMBLE EMBRAYAGE
BAUGRUPPE KUPPLUNG • CONJUNTO EMBRAGUE

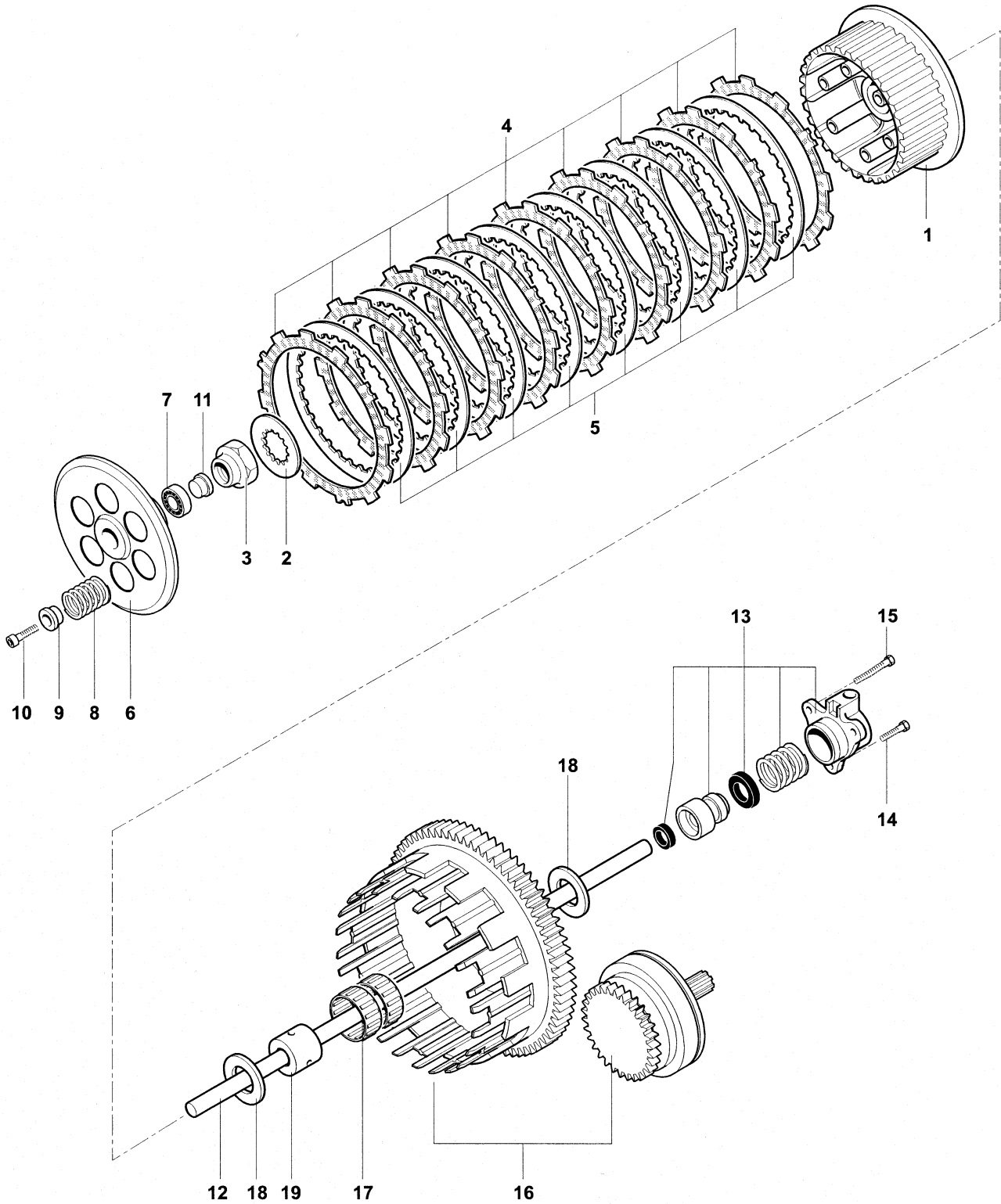

ASSIEME FRIZIONE

 CLUTCH ASSEMBLY • ENSEMBLE EMBRAYAGE
 BAUGRUPPE KUPPLUNG • CONJUNTO EMBRAGUE

N.	Code	Q.ty	Note	BRUTALE ORO	BRUTALE S	►I FRAME I►	►I ENGINE I►
1	800091926	1		•	•		
2	800081451	1		•	•		
3	800091924	1		•	•		
4	800081511	9		•	•		
5	800081510	8		•	•		
6	800081508	1		•	•		
7	800034317	1		•	•		
8	800081516	6		•	•		
9	800081519	6		•	•		
10	60N102513	6		•	•		
11	800081402	1		•	•		
12	800088342	1		•	•		
13	80A081478	1		•	•		
14	800062728	2		•	•		
15	800067545	1		•	•		
16	800096426	1		•	•		
17	800088418	1		•	•		
18	800081517	2		•	•		
18	800081517	2			•		06446 I► ►I 09191 10410 I► ►I 10967
18	8A0081517	2			•		09192 I► ►I 10409 10968 I►
19	800087313	1		•			
19	800087313	1			•		06446 I► ►I 09191 10410 I► ►I 10967
19	8A0087313	1			•		09192 I► ►I 10409 10968 I►



ASSIEME CAMBIO

CHANGE GEAR ASSEMBLY • ENSEMBLE BOÎTE DE VITESSE
BAUGRUPPE GETRIEBE • CONJUNTO CAMBIO

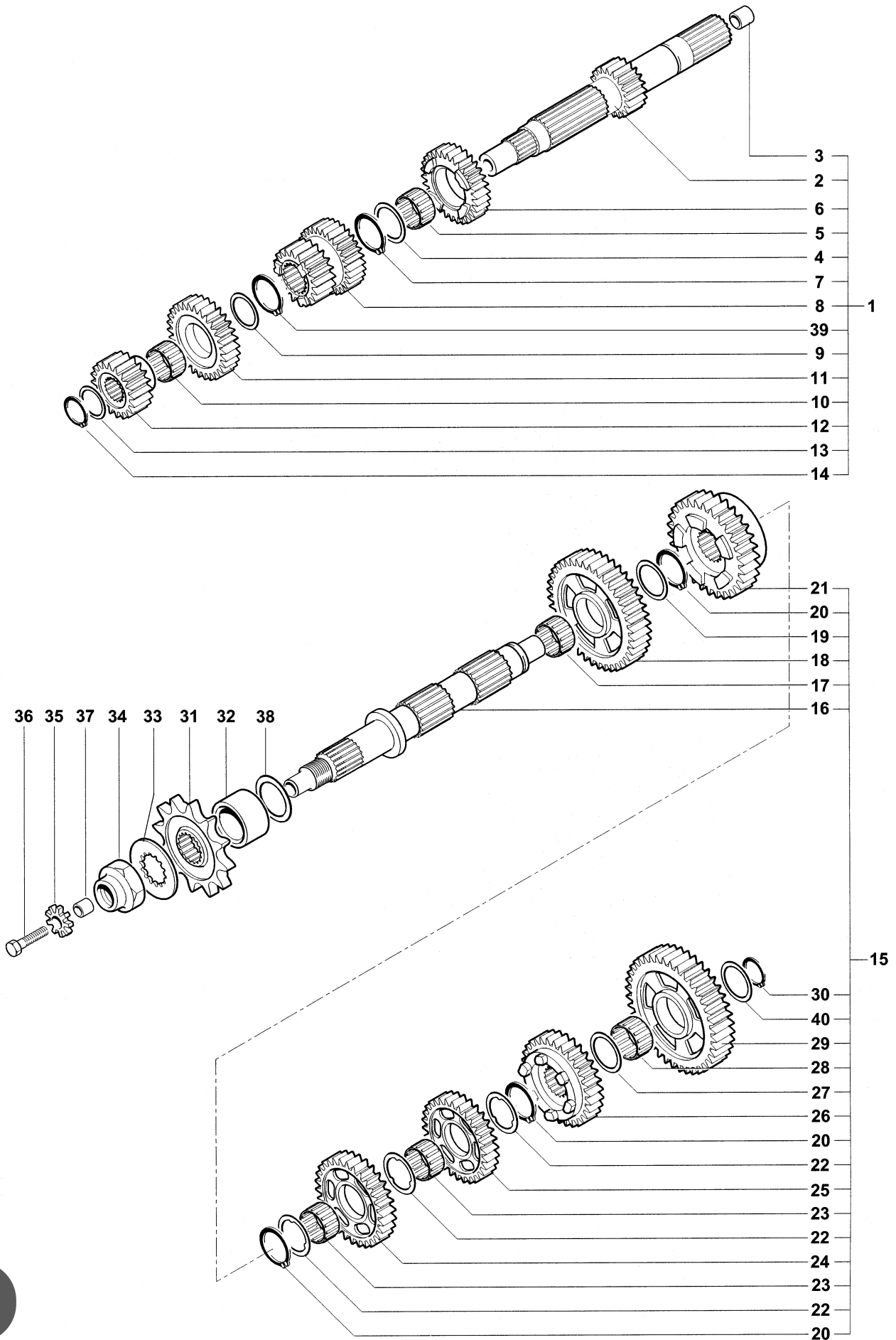

ASSIEME CAMBIO

 CHANGE GEAR ASSEMBLY • ENSEMBLE BOÎTE DE VITESSE
 BAUGRUPPE GETRIEBE • CONJUNTO CAMBIO



N.	Code	Q.ty	Note	BRUTALE ORO	BRUTALE S	►I FRAME I►	►I ENGINE I►
1	8000A2530	1		•			
1	8000A2530	1			•		06446 I► ►I 09191 10410 I► ►I 10967
1	8000A2643	1			•		09192 I► ►I 10409 10968 I►
2	8000A2629	1		•			
2	8000A2629	1			•		06446 I► ►I 09191 10410 I► ►I 10967
2	8000A2644	1			•		09192 I► ►I 10409 10968 I►
3	800086699	1		•	•		
4	8000A0973	1		•	•		
5	8000A0370	1		•	•		
6	8000A2630	1		•	•		
7	8000A0975	1		•	•		
8	8000A2631	1		•	•		
9	8D0081569	1		•			
9	8D0081569	1			•		06446 I► ►I 09191 10410 I► ►I 10967
9	8000A0973	1			•		09192 I► ►I 10409 10968 I►
10	8A0025044	1		•			
10	8A0025044	1			•		06446 I► ►I 09191 10410 I► ►I 10967
10	8000A0370	1			•		09192 I► ►I 10409 10968 I►
11	8000A2532	1		•			
11	8000A2532	1			•		06446 I► ►I 09191 10410 I► ►I 10967
11	8000A1956	1			•		09192 I► ►I 10409 10968 I►
12	8000A2633	1		•			
12	8000A2633	1			•		06446 I► ►I 09191 10410 I► ►I 10967
12	8000A2645	1			•		09192 I► ►I 10409 10968 I►



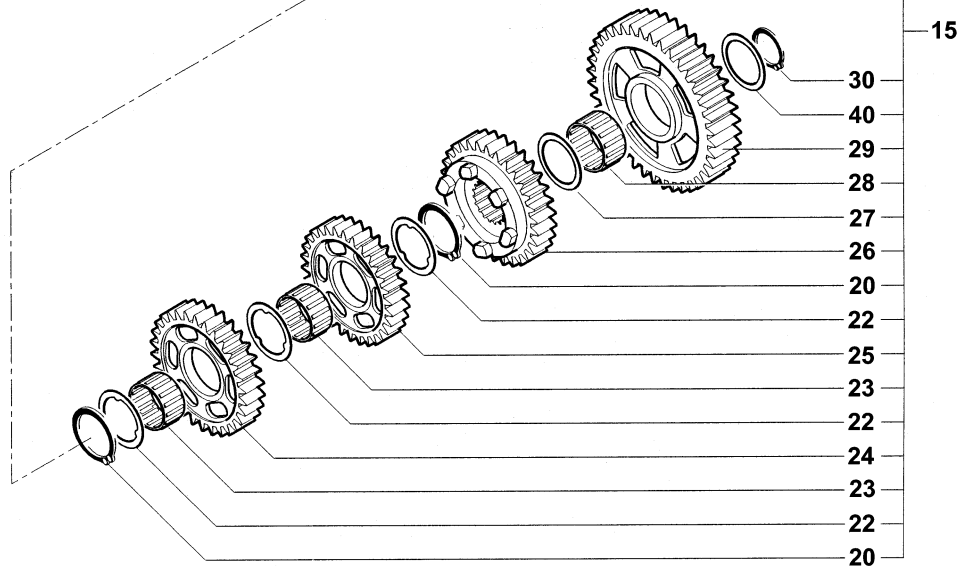
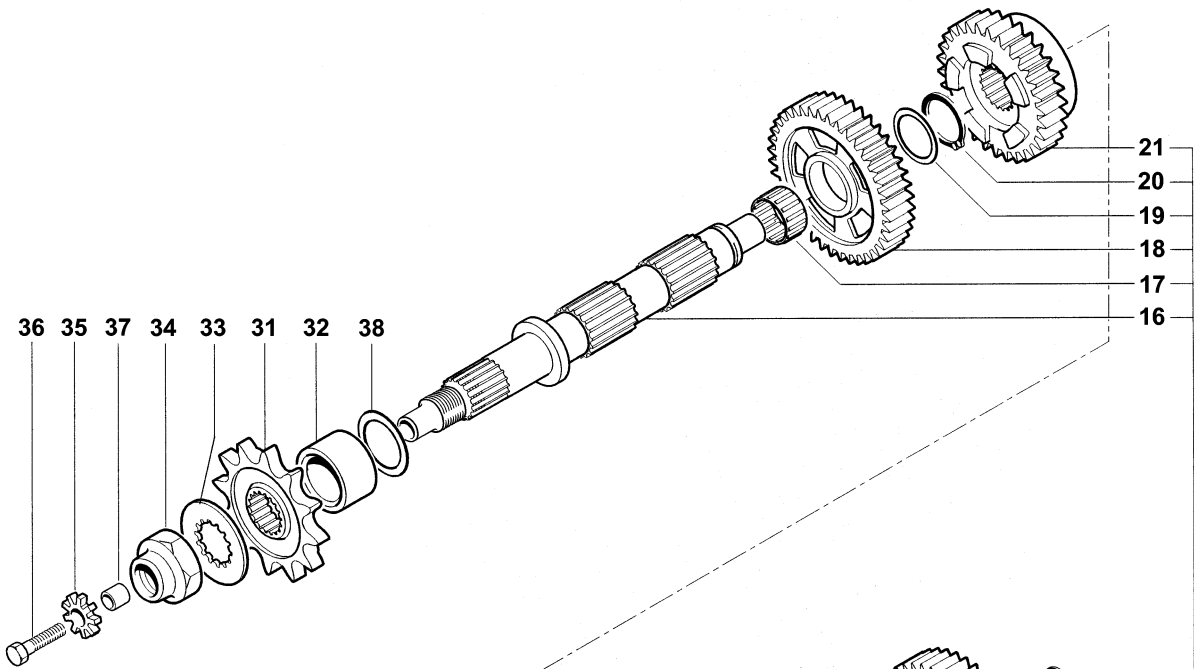
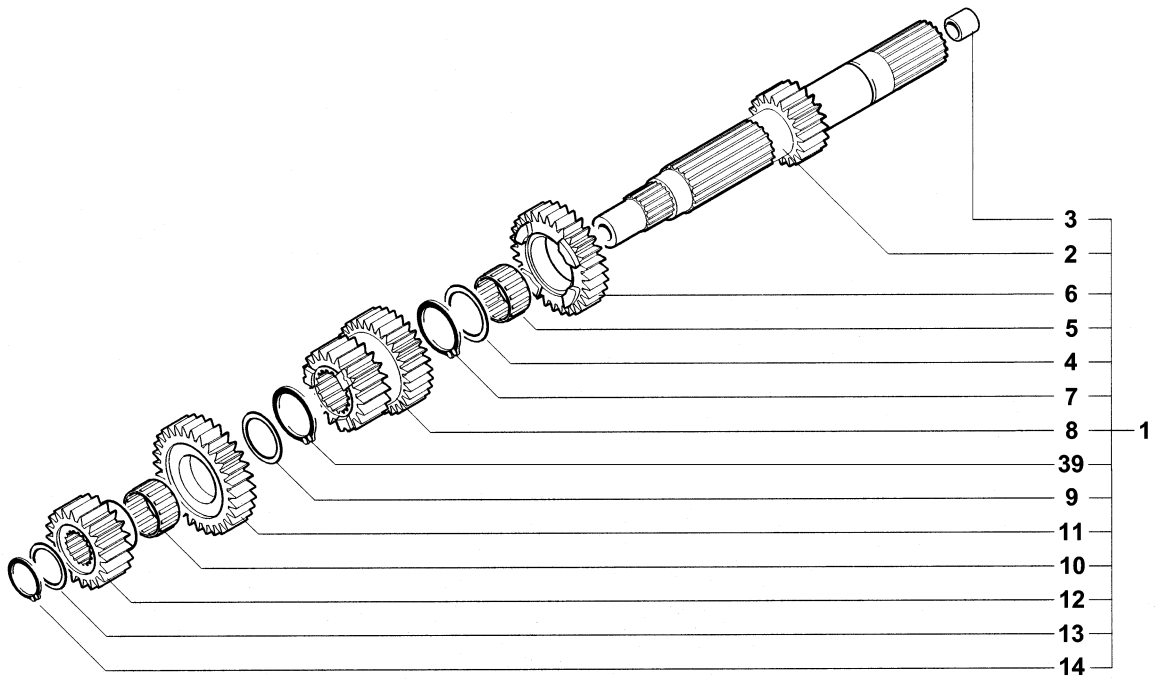

ASSIEME CAMBIO

CHANGE GEAR ASSEMBLY • ENSEMBLE BOÎTE DE VITESSE
BAUGRUPPE GETRIEBE • CONJUNTO CAMBIO



ASSIEME CAMBIO

 CHANGE GEAR ASSEMBLY • ENSEMBLE BOÎTE DE VITESSE
 BAUGRUPPE GETRIEBE • CONJUNTO CAMBIO



N.	Code	Q.ty	Note	BRUTALE ORO	BRUTALE S	►I FRAME I►	►I ENGINE I►
13	8G0048590	1		•			
13	8G0048590	1			•		06446 I► ►I 09191 10410 I► ►I 10967
13	8D0081569	1			•		09192 I► ►I 10409 10968 I►
14	66N221207	1		•			
14	66N221207	1			•		06446 I► ►I 09191 10410 I► ►I 10967
14	66N221210	1			•		09192 I► ►I 10409 10968 I►
15	8000A2531	1		•			
15	8000A2531	1			•		06446 I► ►I 09191 10410 I► ►I 10967
15	8000A2646	1			•		09192 I► ►I 10409 10968 I►
16	8000A0980	1		•			
16	8000A0980	1			•		06446 I► ►I 09191 10410 I► ►I 10967
16	8000A1072	1			•		09192 I► ►I 10409 10968 I►
17	8000A0370	1		•	•		
18	8000A2635	1		•			
18	8000A2635	1			•		06446 I► ►I 09191 10410 I► ►I 10967
18	8000A2650	1			•		09192 I► ►I 10409 10968 I►
19	8000A0982	1		•			
19	8000A0982	1			•		06446 I► ►I 09191 10410 I► ►I 10967
19	8000A4196	1			•		09192 I► ►I 10409 10968 I►
20	8000A0990	3		•	•		
21	8000A1957	1		•	•		
22	8000A0982	3		•			
22	8000A0982	3			•		06446 I► ►I 09191 10410 I► ►I 10967



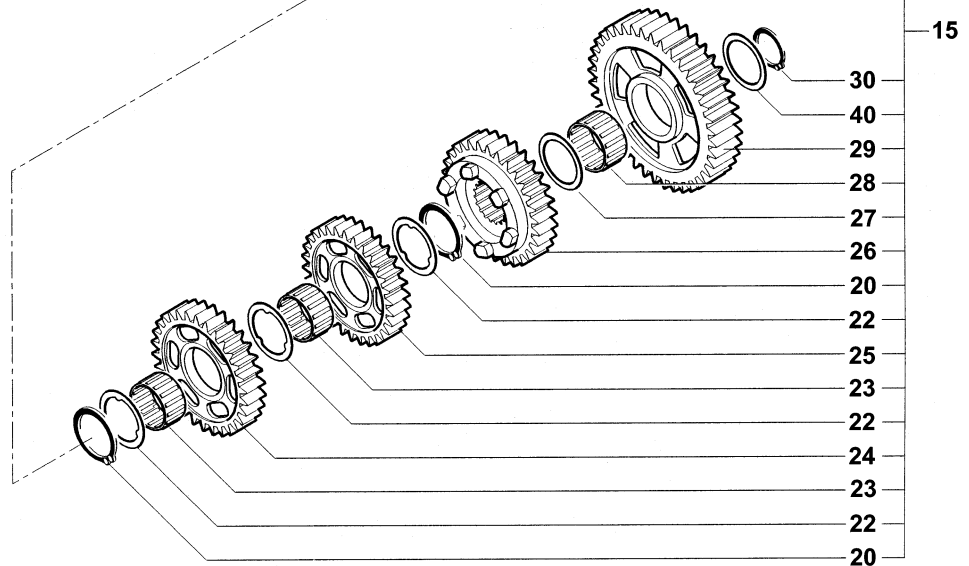
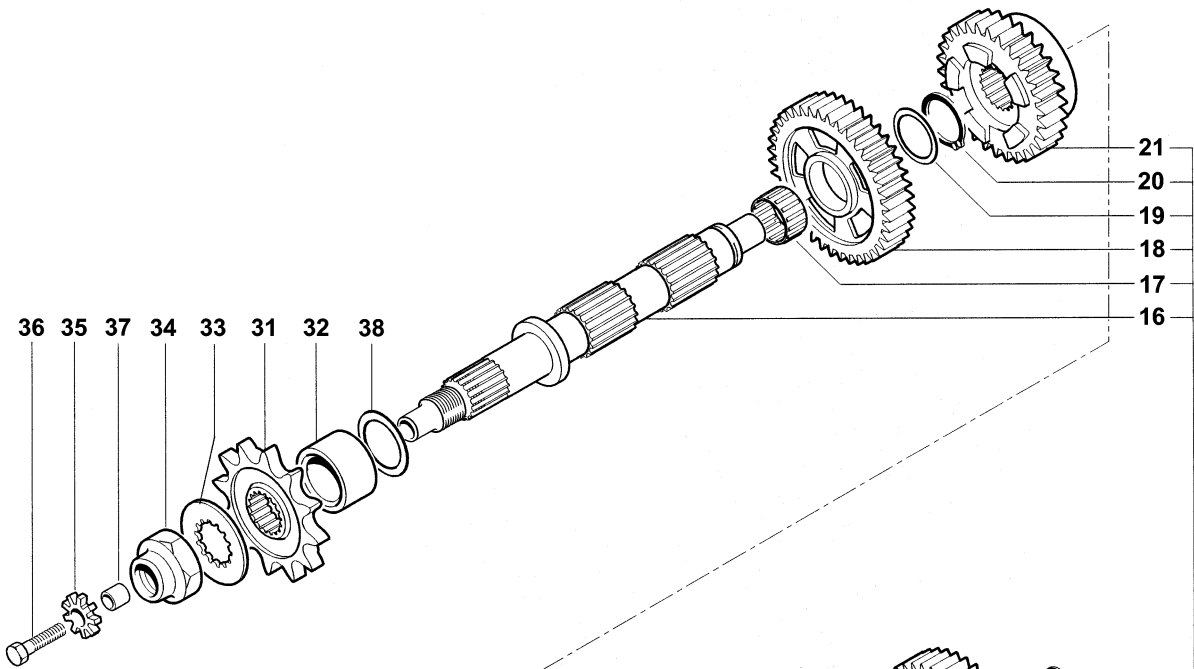
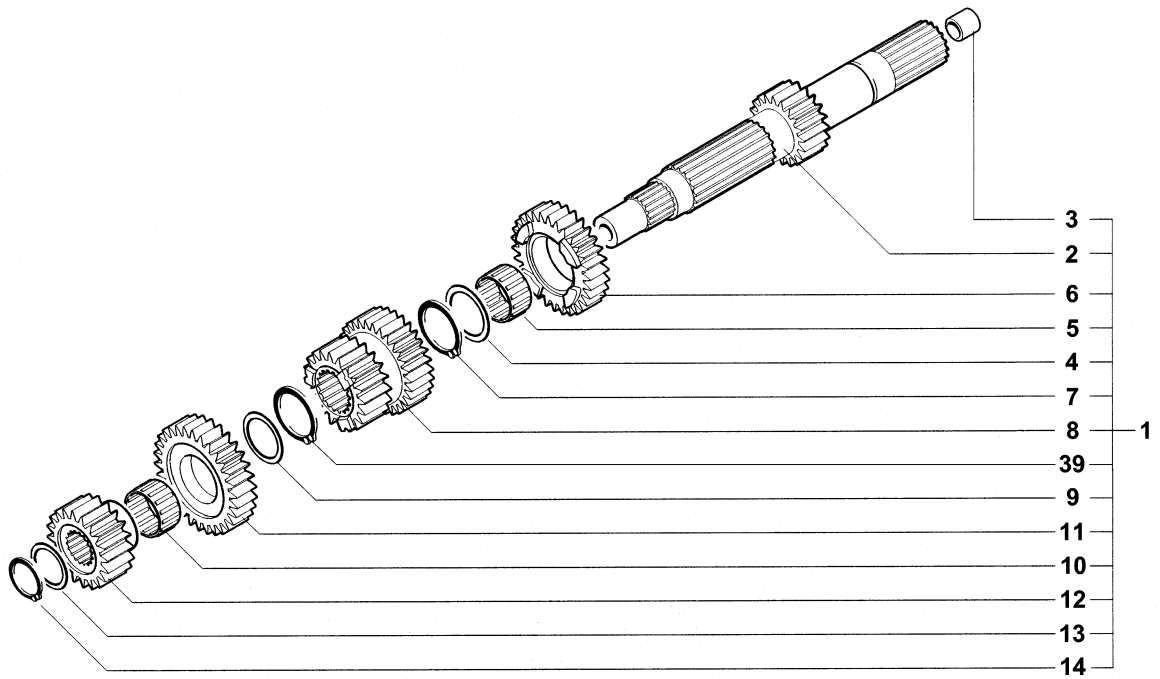

ASSIEME CAMBIO

CHANGE GEAR ASSEMBLY • ENSEMBLE BOÎTE DE VITESSE
BAUGRUPPE GETRIEBE • CONJUNTO CAMBIO



ASSIEME CAMBIO

 CHANGE GEAR ASSEMBLY • ENSEMBLE BOÎTE DE VITESSE
 BAUGRUPPE GETRIEBE • CONJUNTO CAMBIO



N.	Code	Q.ty	Note	BRUTALE ORO	BRUTALE S	► I FRAME I ►	► I ENGINE I ►
22	8000A4196	3			•		09192 I ► ► I 10409 10968 I ►
23	8000A0370	2		•	•		
24	8000A2637	1		•	•		
25	8000A2638	1		•	•		
26	8000A2639	1		•	•		
27	8000A0987	1		•	•		
28	8000A0370	1		•	•		
29	8000A2640	1		•	•		
30	66N221212	1		•			
30	66N221212	1			•		06446 I ► ► I 09191 10410 I ► ► I 10967
30	66N221210	1			•		09192 I ► ► I 10409 10968 I ►
31	800098555	1		•	•		
32	8A0081466	1		•			
32	8A0081466	1			•		06446 I ► ► I 09191 10410 I ► ► I 10967
32	8000A2319	1			•		09192 I ► ► I 10409 10968 I ►
33	800081451	1		•	•		
34	800091924	1		•	•		
35	800088343	1		•	•		
36	800062728	1		•	•		
37	800051549	1		•	•		
38	800096565	1	≠ 1.4	•			
38	8A0096565	1	≠ 1.5	•			
38	8B0096565	1	≠ 1.6	•			
38	800096565	1	≠ 1.4		•		06446 I ► ► I 09191 10410 I ► ► I 10967
38	8A0096565	1	≠ 1.5		•		06446 I ► ► I 09191 10410 I ► ► I 10967
38	8B0096565	1	≠ 1.6		•		06446 I ► ► I 09191 10410 I ► ► I 10967
38	8000A1234	1	≠ 1.4		•		09192 I ► ► I 10409 10968 I ►
38	8A00A1234	1	≠ 1.5		•		09192 I ► ► I 10409 10968 I ►



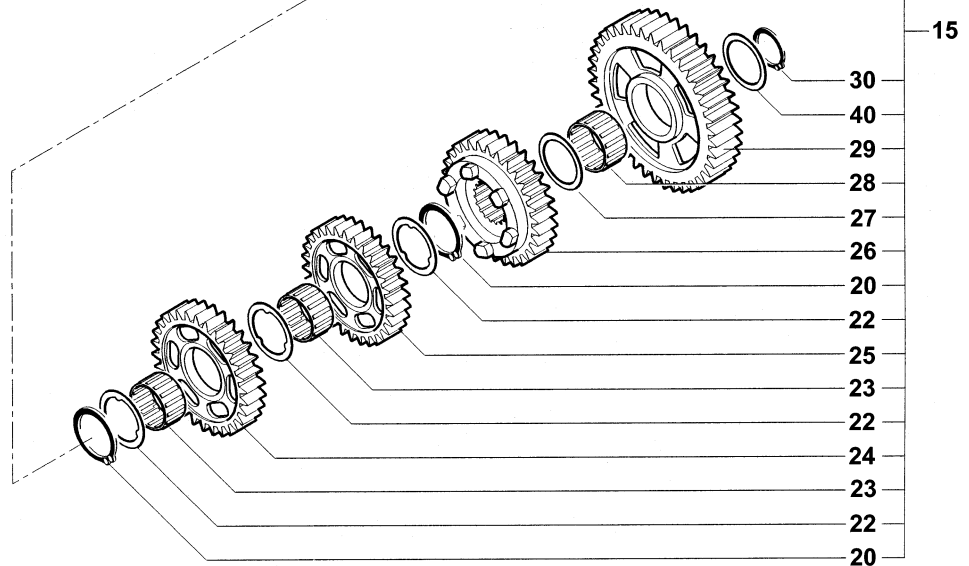
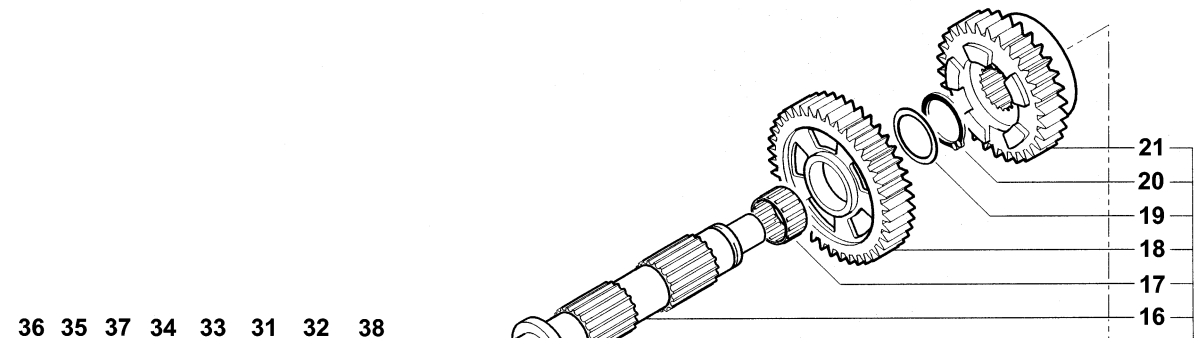
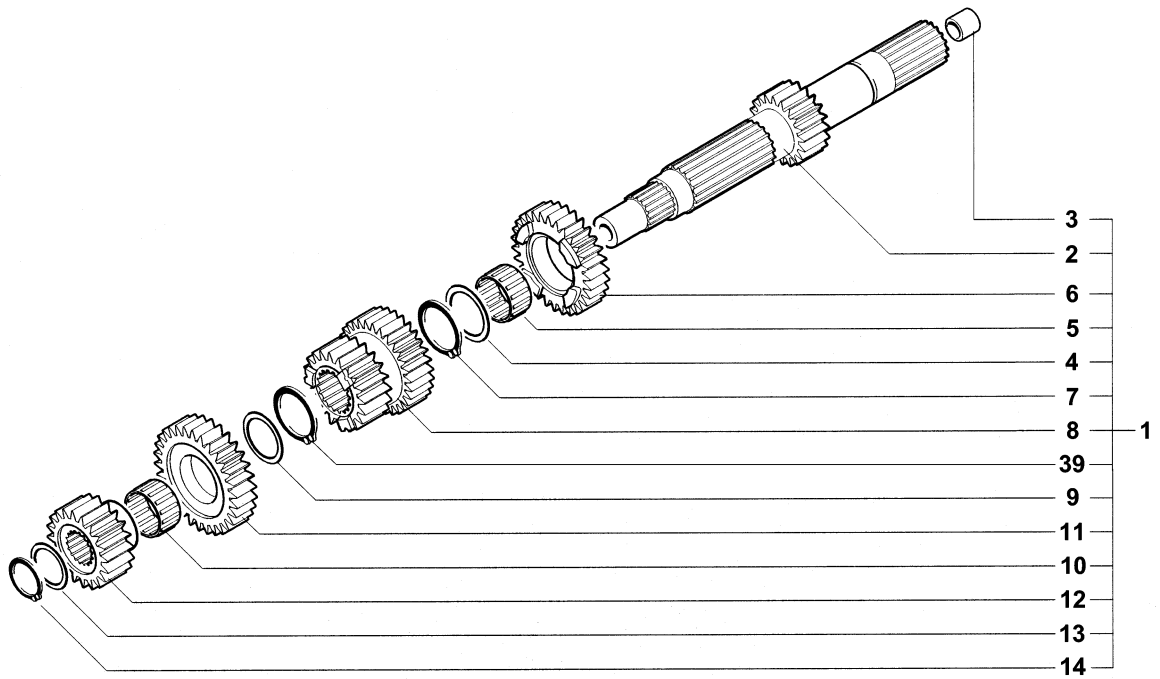

ASSIEME CAMBIO

CHANGE GEAR ASSEMBLY • ENSEMBLE BOÎTE DE VITESSE
BAUGRUPPE GETRIEBE • CONJUNTO CAMBIO



ASSIEME CAMBIOCHANGE GEAR ASSEMBLY • ENSEMBLE BOÎTE DE VITESSE
BAUGRUPPE GETRIEBE • CONJUNTO CAMBIO

N.	Code	Q.ty	Note	BRUTALE ORO	BRUTALE S	►I FRAME I►	►I ENGINE I►
38	8B00A1234	1	≠ 1.6		•		09192 I► ►I 10409 10968 I►
39	8000A0975	1			•		09192 I► ►I 10409 10968 I►
40	8000A0987	1		•			
40	8000A0987	1			•		12314 I► ►I 12415 12537 I►
40	8000A4780	1			•		►I 12315 12414 I► ►I 12538





SELETORE CAMBIO
GEAR SELECTOR • SÉLECTEUR DE VITESSES
GANGSCHALTER • SELECTOR CAMBIO

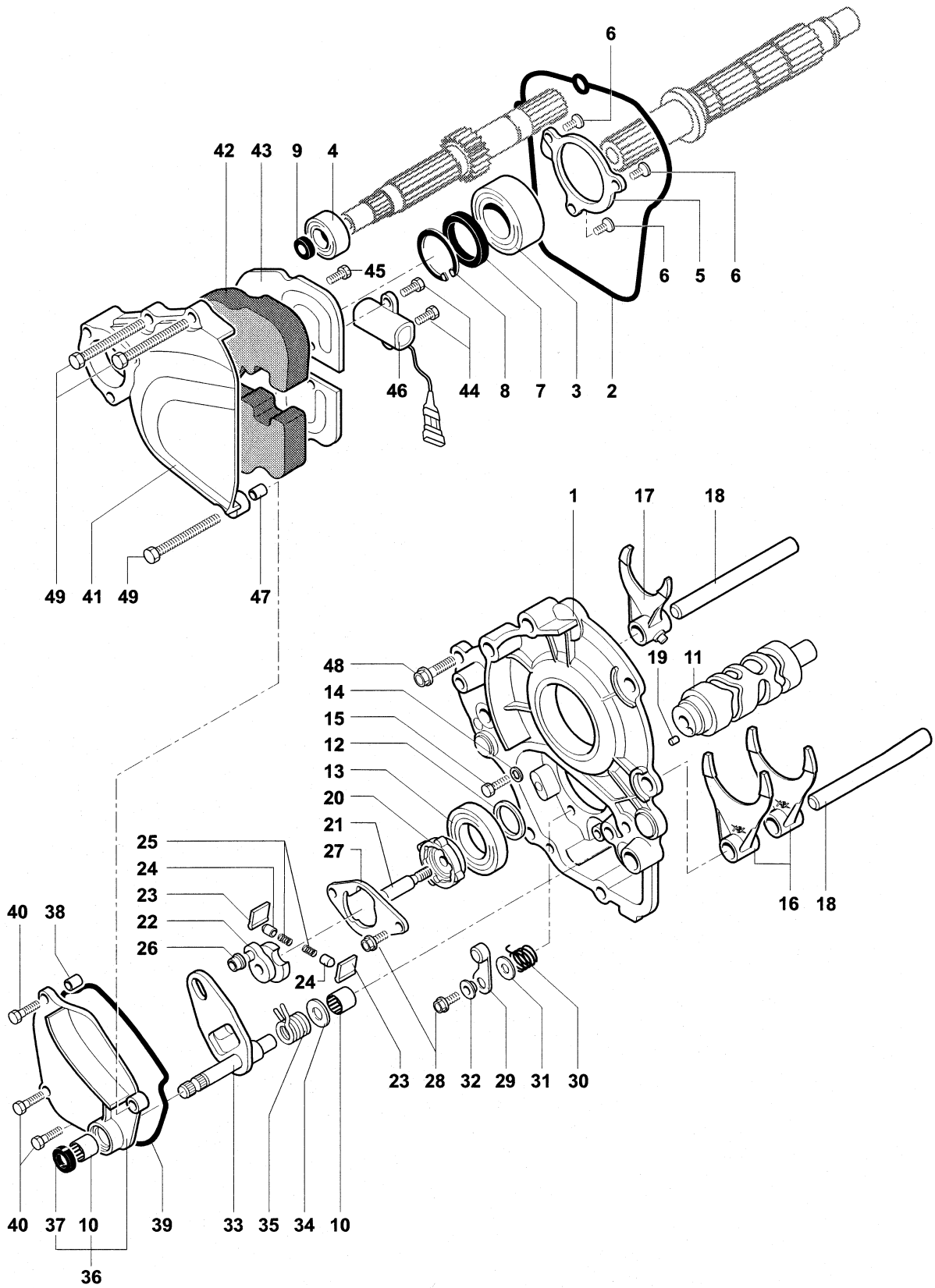

SELETTORE CAMBIO

 GEAR SELECTOR • SÉLECTEUR DE VITESSES
 GANGSCHALTER • SELECTOR CAMBIO

N.	Code	Q.ty	Note	BRUTALE ORO	BRUTALE S	► I FRAME I ►	► I ENGINE I ►
1	800099106	1		•	•		
2	800086117	1		•	•		
3	8000A3754	1		•			
3	8000A3754	1			•		06446 I ► ► I 09191 10410 I ► ► I 10967
3	8000A2318	1			•		09192 I ► ► I 10409 10968 I ►
4	800086116	1		•			
4	800086116	1			•		06446 I ► ► I 09191 10410 I ► ► I 10967
4	8000A1086	1			•		09192 I ► ► I 10409 10968 I ►
5	800086114	1		•	•		
6	800028327	3		•	•		
7	800089410	1		•	•		
8	800091603	1		•	•		
9	800064296	1		•	•		
10	800051191	2		•	•		
11	8A0089416	1		•	•		
12	8A0036022	1	≠ 0.2 mm	•	•		
12	8B0036022	1	≠ 0.3 mm	•	•		
12	8C0036022	1	≠ 0.4 mm	•	•		
13	8A0021774	1		•	•		
14	8000A0901	2		•	•		
15	800062726	2		•	•		
16	800081583	2		•	•		
17	8A0081584	1		•	•		
18	800081585	2		•	•		
19	800038520	1		•	•		
20	8A0097739	1		•	•		
21	800098149	1		•	•		
22	800087299	1		•	•		
23	800071007	2		•	•		
24	800071008	2		•	•		
25	800071009	2		•	•		
26	800071010	1		•	•		
27	800081590	1		•	•		
28	800062726	3		•	•		
29	800085495	1		•	•		
30	800092490	1		•	•		
31	800086107	1		•	•		
32	800085493	1		•	•		
33	800089424	1		•	•		
34	8G0004551	1		•	•		
35	800072826	1		•	•		
36	800099107	1		•	•		
37	8A0028855	1		•	•		
38	800051549	1		•	•		
39	800089406	1		•	•		





SELETTORE CAMBIO
GEAR SELECTOR • SÉLECTEUR DE VITESSES
GANGSCHALTER • SELECTOR CAMBIO

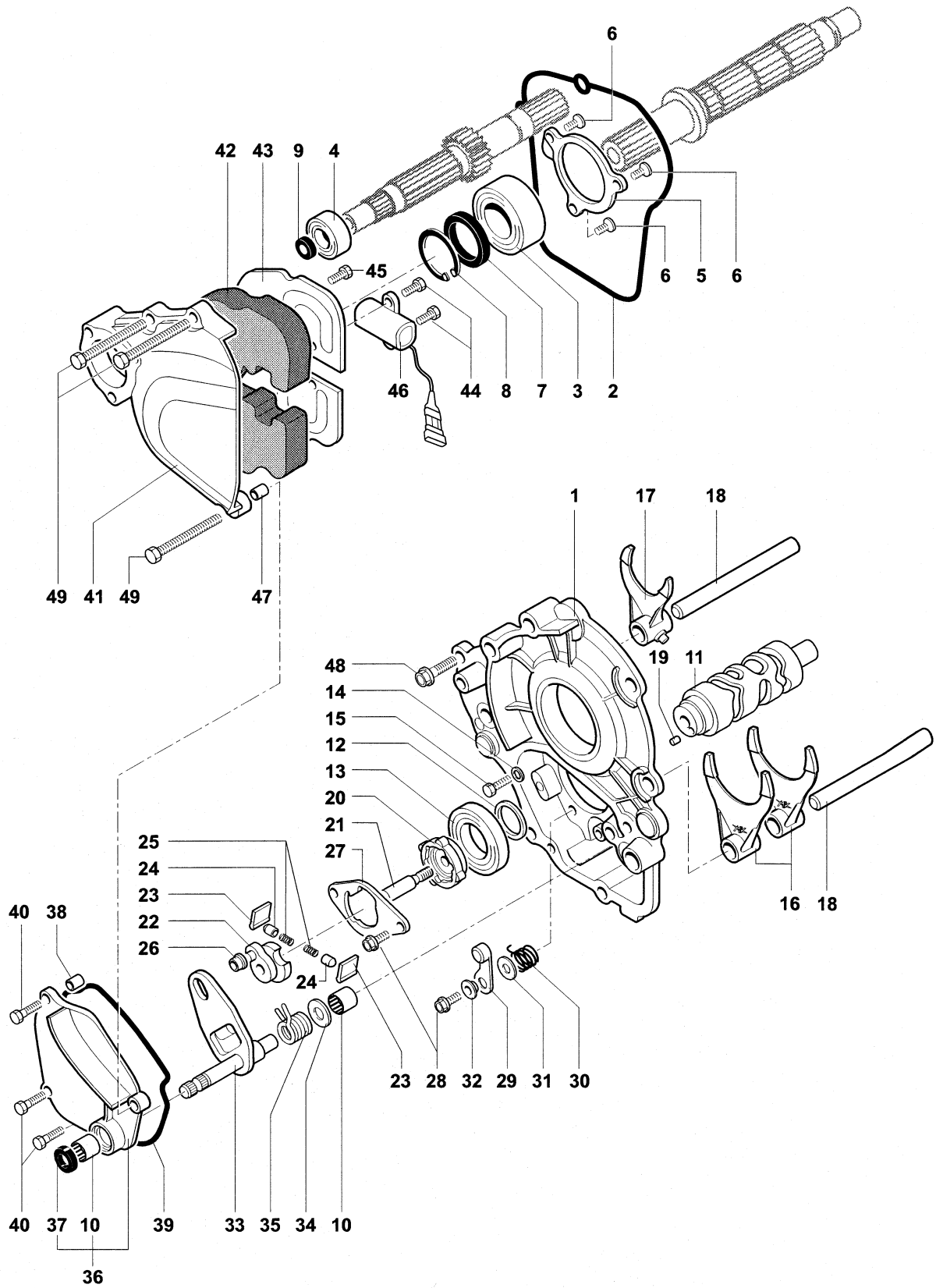

SELETTORE CAMBIOGEAR SELECTOR • SÉLECTEUR DE VITESSES
GANGSCHALTER • SELECTOR CAMBIO

N.	Code	Q.ty	Note	BRUTALE ORO	BRUTALE S	► I FRAME I ►	► I ENGINE I ►
40	800062729	3		•	•		
41	80A092494	1		•	•		
42	800088347	1		•	•		
43	800088344	1		•	•		
44	800067997	2		•	•		
45	8D0067997	1		•	•		
46	800088346	1		•	•		
47	800086131	2		•	•		
48	800091697	6		•	•		
49	8B0091697	3		•	•		





GRUPPO POMPA BENZINA

FUEL PUMP ASSEMBLY • GROUPE POMPE D'ALIMENTATION
BAUGRUPPE BENZINPUMPE • GRUPO BOMBA GASOLINA

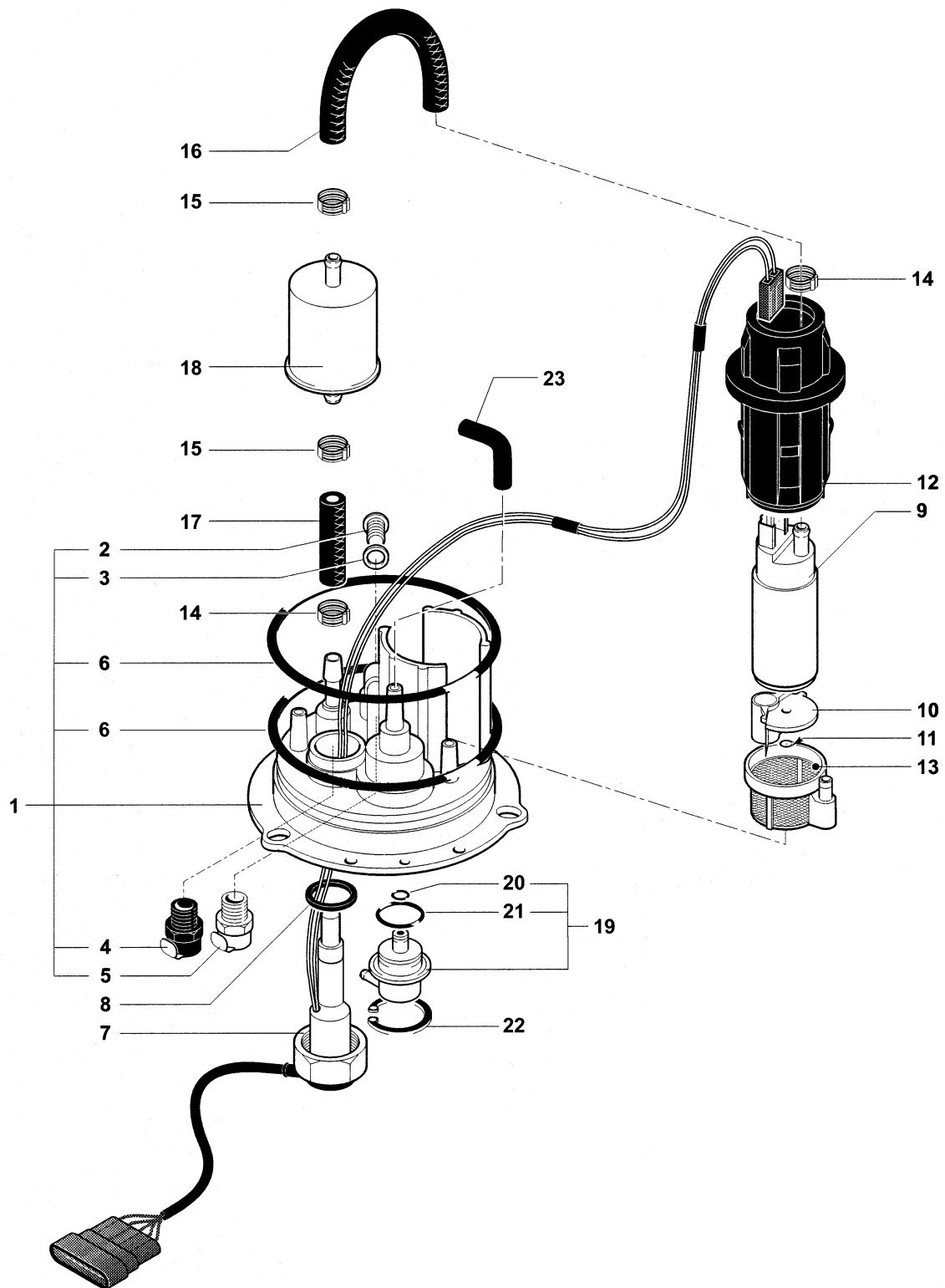

GRUPPO POMPA BENZINAFUEL PUMP ASSEMBLY • GROUPE POMPE D'ALIMENTATION
BAUGRUPPE BENZINPUMPE • GRUPO BOMBA GASOLINA

N.	Code	Q.ty	Note	BRUTALE ORO	BRUTALE S	► I FRAME I ►	► I ENGINE I ►
1	8A0094275	1		•	•		
2	800090927	1		•	•		
3	800021480	1		•	•		
4	80A090925	1		•	•		
5	800090925	1		•	•		
6	800090939	2		•	•		
7	8000A1400	1		•	•		
8	800090919	1		•	•		
9	800090920	1		•	•		
10	800093410	1		•	•		
11	800093411	1		•	•		
12	800090921	1		•	•		
13	800098305	1		•	•		
14	8M0092249	2		•	•		
15	8S0092249	2		•	•		
16	8E0087431	1		•	•		
17	8H0087431	1		•	•		
18	800088585	1		•	•		
19	800090929	1		•	•		
20	800093323	1		•	•		
21	800093324	1		•	•		
22	800090930	1		•	•		
23	800098304	1		•	•		



ALIMENTAZIONE MOTORE
FUEL SYSTEM • ALIMENTATION MOTEUR
MOTORVERSORGUNG • ALIMENTACIÓN MOTOR

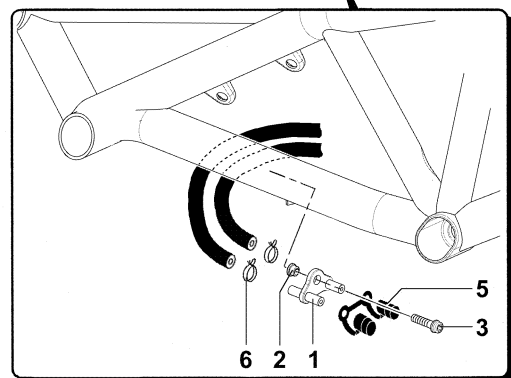
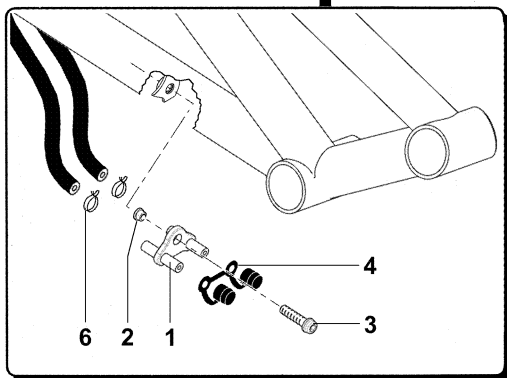
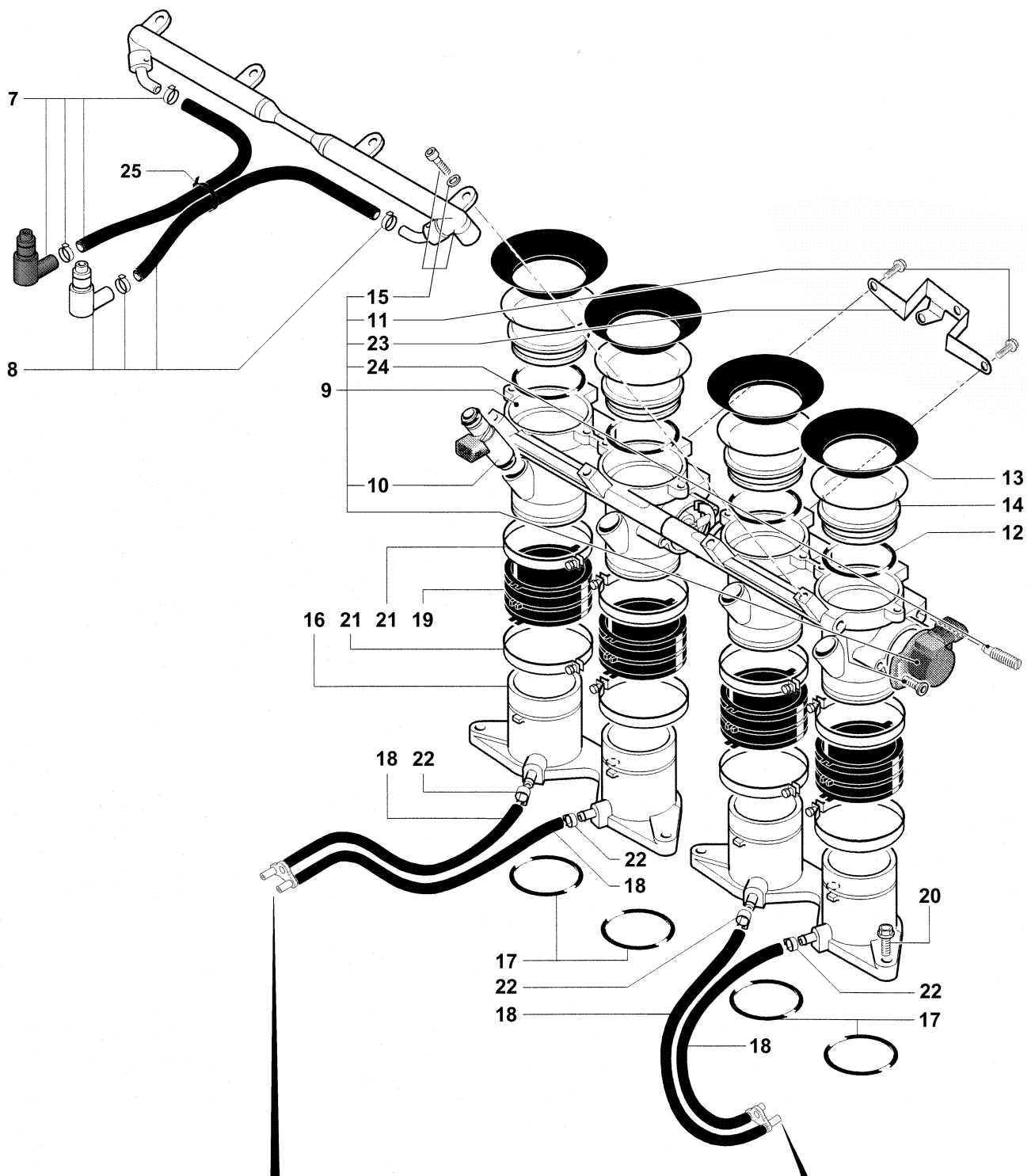



N.	Code	Q.ty	Note	BRUTALE ORO	BRUTALE S	► I FRAME I ►	► I ENGINE I ►
1	800089801	2		•	•		
2	800067412	2		•	•		
3	8C0090424	2		•	•		
4	800089799	1	❶	•	•		
5	800089800	1	❶	•	•		
6	8A0091634	4		•	•		
7	80A0A1558	1		•	•		
8	8000A1558	1		•	•		
9	8000A4827	1		•	•		
10	8000A1440	1		•	•		
11	8E0067997	2		•	•		
12	800081304	4		•	•		
13	800090350	4		•	•		
14	800091595	4		•	•		
15	8000A1442	1		•	•		
16	800099101	2		•	•		
17	800019965	4		•	•		
18	8B0091037	4		•	•		
19	800089403	4		•	•		
20	8PA067545	6		•	•		
21	800089404	8		•	•		
22	800096458	4		•	•		
23	8000A1453	1		•	•		
24	8000A1455	2		•	•		
25	800056444	1		•	•		

❶ Esclusi gli USA (vedi tavola K02) - USA excluded (see table K02) - Sauf les USA (voir planche K02) - Ausschließlich USA (siehe Tafel K02) - Excluidos los USA (ver tabla K02).



AVVIAMENTO

STARTING SYSTEM • DÉMARREUR

ANLASSERSYSTEM • PUESTA EN MARCHA

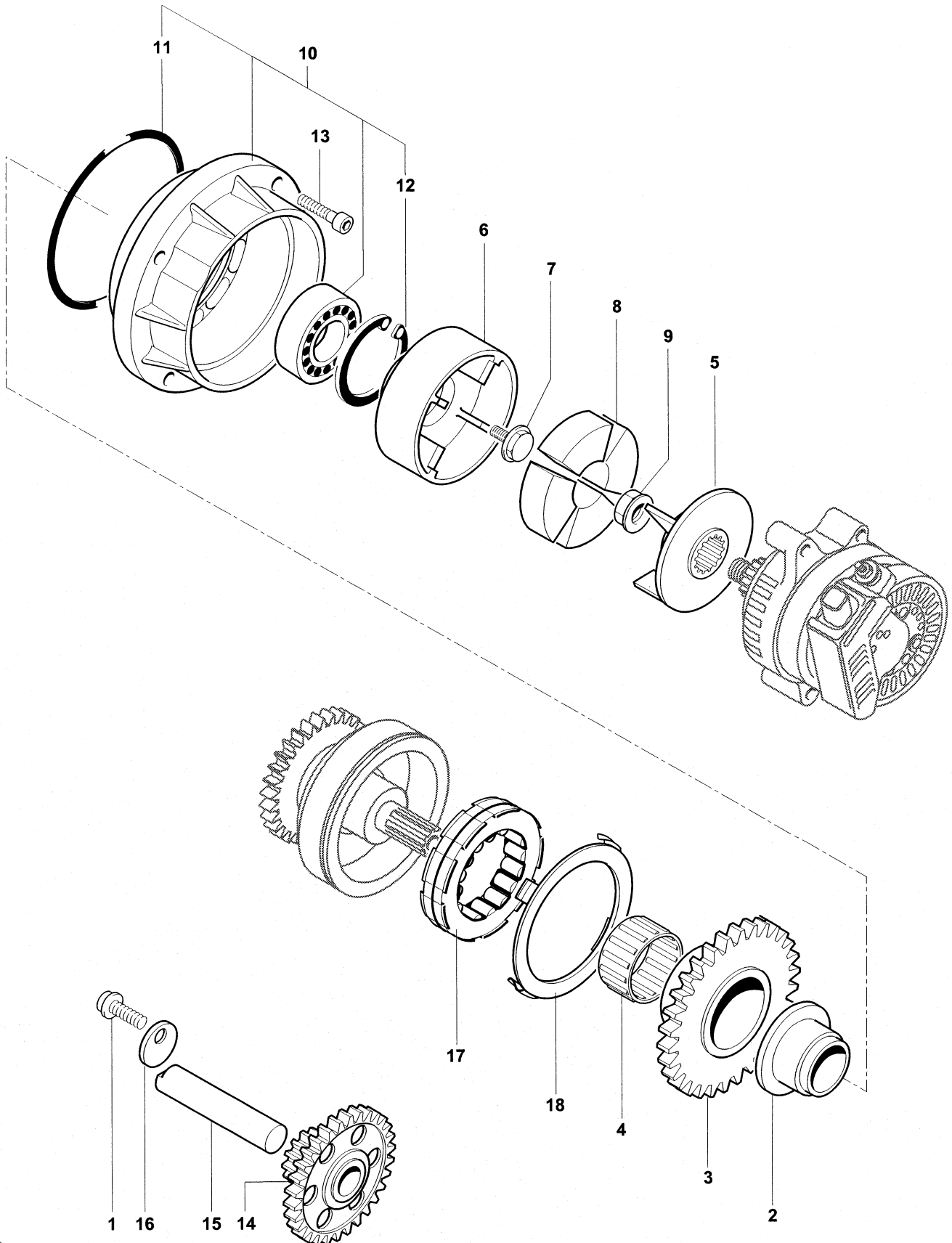

AVVIAMENTO
 STARTING SYSTEM • DÉMARREUR
 ANLASSERSYSTEM • PUESTA EN MARCHA



N.	Code	Q.ty	Note	BRUTALE ORO	BRUTALE S	► I FRAME I ►	► I ENGINE I ►
1	800062726	1		•	•		
2	800086208	1		•	•		
3	800087288	1		•	•		
4	800048551	1		•	•		
5	800081445	1		•	•		
6	800087290	1		•	•		
7	800081393	1		•	•		
8	8000A3812	4		•	•		
9	800038624	1		•	•		
10	800081461	1		•	•		
11	800081453	1		•	•		
12	66N021272	1		•	•		
13	60N102509	4		•	•		
14	800091886	1		•	•		
15	800081380	1		•	•		
16	800081381	1		•	•		
17	800087289	1		•	•		
18	800086732	1		•	•		



IMPIANTO ELETTRICO MOTORE

ENGINE ELECTRIC SYSTEM • INSTALLATION ÉLECTRIQUE MOTEUR
ELEKTRISCHE ANLAGE MOTOR • INSTALACIÓN ELÉCTRICA MOTOR

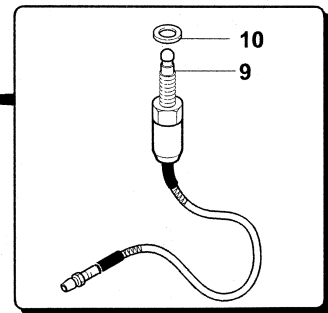
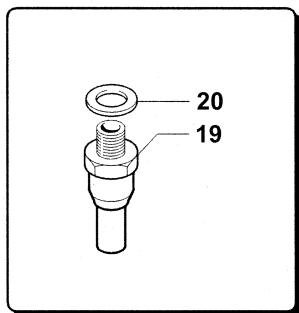
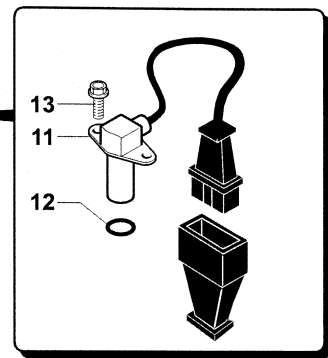
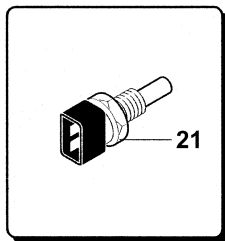
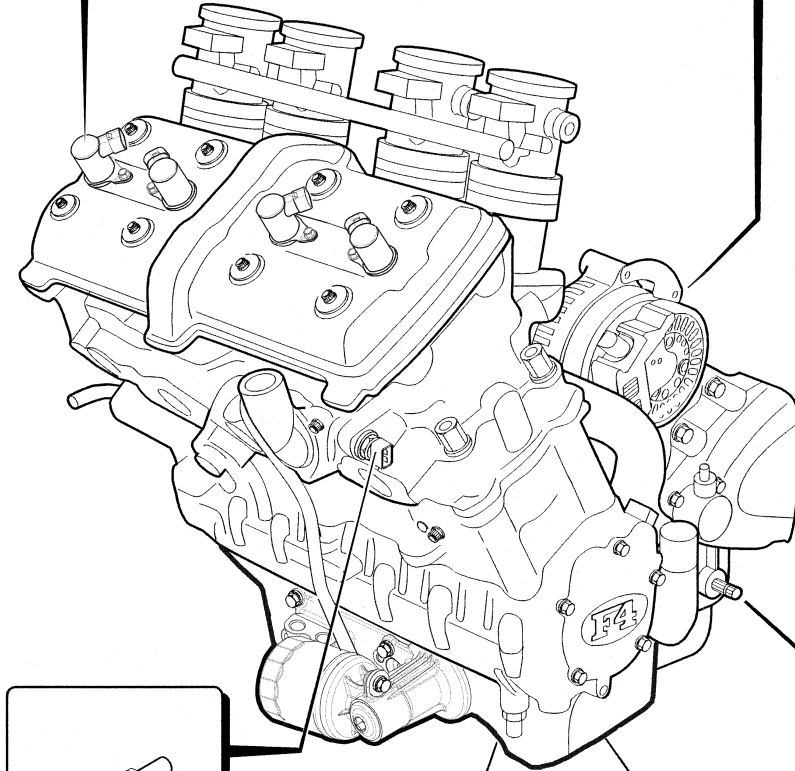
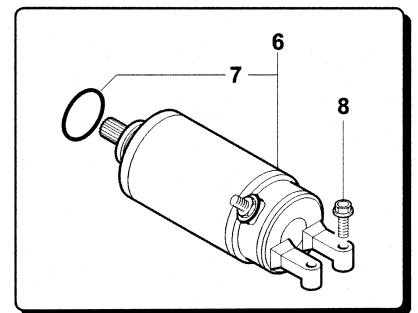
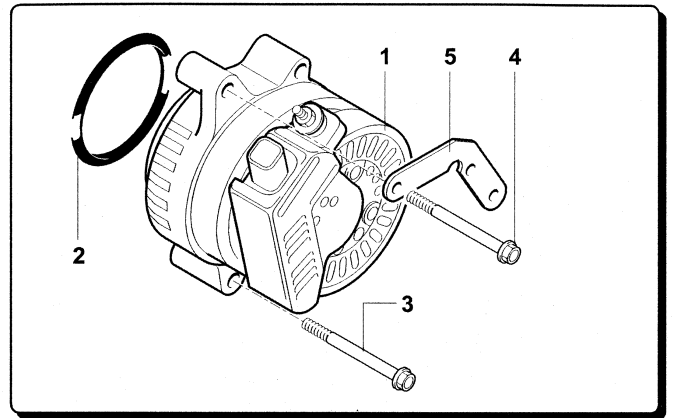
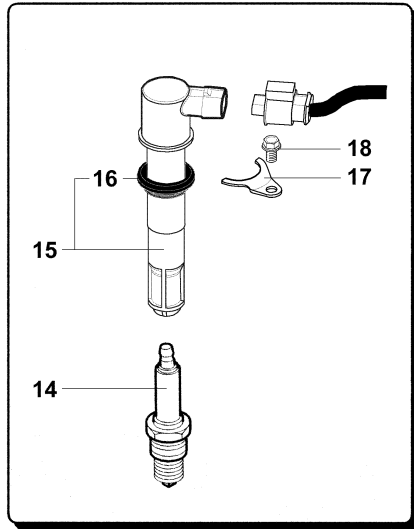

IMPIANTO ELETTRICO MOTORE

 ENGINE ELECTRIC SYSTEM • INSTALLATION ÉLECTRIQUE MOTEUR
 ELEKTRISCHE ANLAGE MOTOR • INSTALACIÓN ELÉCTRICA MOTOR

N.	Code	Q.ty	Note	BRUTALE ORO	BRUTALE S	► I FRAME I ►	► I ENGINE I ►
1	8A0081387	1		•	•		
2	800086223	1		•	•		
3	8C0091697	1		•	•		
4	8B0098219	2		•	•		
5	800097278	1		•	•		
6	800081388	1		•	•		
7	800091597	1		•	•		
8	800062729	2		•	•		
9	800087124	1		•	•		
10	800039335	1		•	•		
11	800090184	1		•	•		
12	800022551	1		•	•		
13	800067997	2		•	•		
14	800090212	4	CHAMPION G59c	•	•		
14	800095906	4	NKG CR9 EB	•	•		
15	8000A0711	4		•	•		
16	8000A0515	4		•	•		
17	800099812	4		•	•		
18	800062725	4		•	•		
19	800089972	1		•	•		
20	62N015676	1		•	•		
21	800088575	1		•	•		



IMPIANTO DI SCARICO
EXHAUST SYSTEM • ÉCHAPPEMENT
ABGASANLAGE • INSTALACIÓN DE ESCAPE

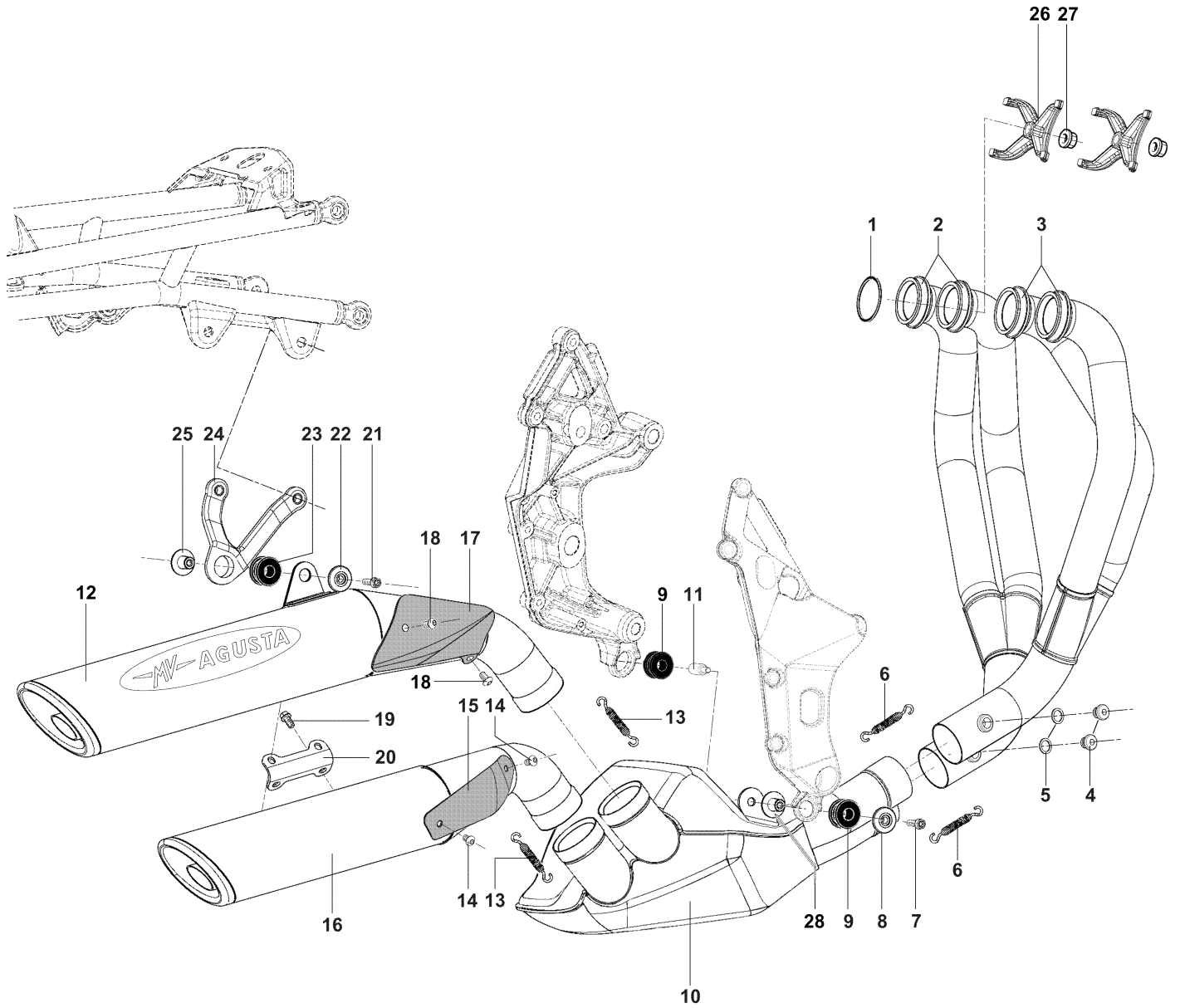

IMPIANTO DI SCARICO
 EXHAUST SYSTEM • ÉCHAPPEMENT
 ABGASANLAGE • INSTALACIÓN DE ESCAPE



N.	Code	Q.ty	Note	BRUTALE ORO	BRUTALE S	► I FRAME I ►	► I ENGINE I ►
1	800099383	4		•	•		
2	800099343	1		•	•		
3	800099344	1		•	•		
4	800090972	2		•	•		
5	800021480	2		•	•		
6	8000A1239	2		•	•		
7	8L0090425	1		•	•		
8	8B0089299	1		•	•		
8	800089299	1			•		
9	800089302	2		•	•		
10	800099345	1		•			
10	800099345	1			•		► I 10760
10	8000A3824	1	①		•		10761 I ►
10	800099345	1	USA		•		
11	800099346	1		•	•		
12	800097881	1		•			
12	800097881	1	②		•		
12	800097881	1	JPN		•		► I 11948
12	8000A4891	1	JPN		•		11949 I ►
13	8000A1239	2		•	•		
14	8A0061070	2		•	•		
15	800099403	1		•	•		
16	800097880	1		•			
16	800097880	1	②		•		
16	800097880	1	JPN		•		► I 11948
16	8000A4892	1	JPN		•		11949 I ►
17	800099349	1		•	•		
18	8A0061070	2		•	•		
19	8H0067545	4		•	•		
20	800099347	1		•	•		
21	8G0090425	1		•	•		
22	8A0089299	1		•	•		
23	800089302	1		•	•		
24	80A099139	1		•	•		
25	800099348	1		•	•		
26	800090419	2		•	•		
27	80B043928	2		•	•		
28	8000A1952	1			•		

① Esclusi gli USA - USA excluded - Sauf les USA - Ausschließlich USA - Excluidos los USA.

② Escluso il Giappone - Japan excluded - Sauf le Japon - Ausschließlich Japan - Excluido el Japón.



DOTAZIONI

OUTFIT • ÉQUIPEMENT
BORDWERKZEUG • EQUIPAMIENTO

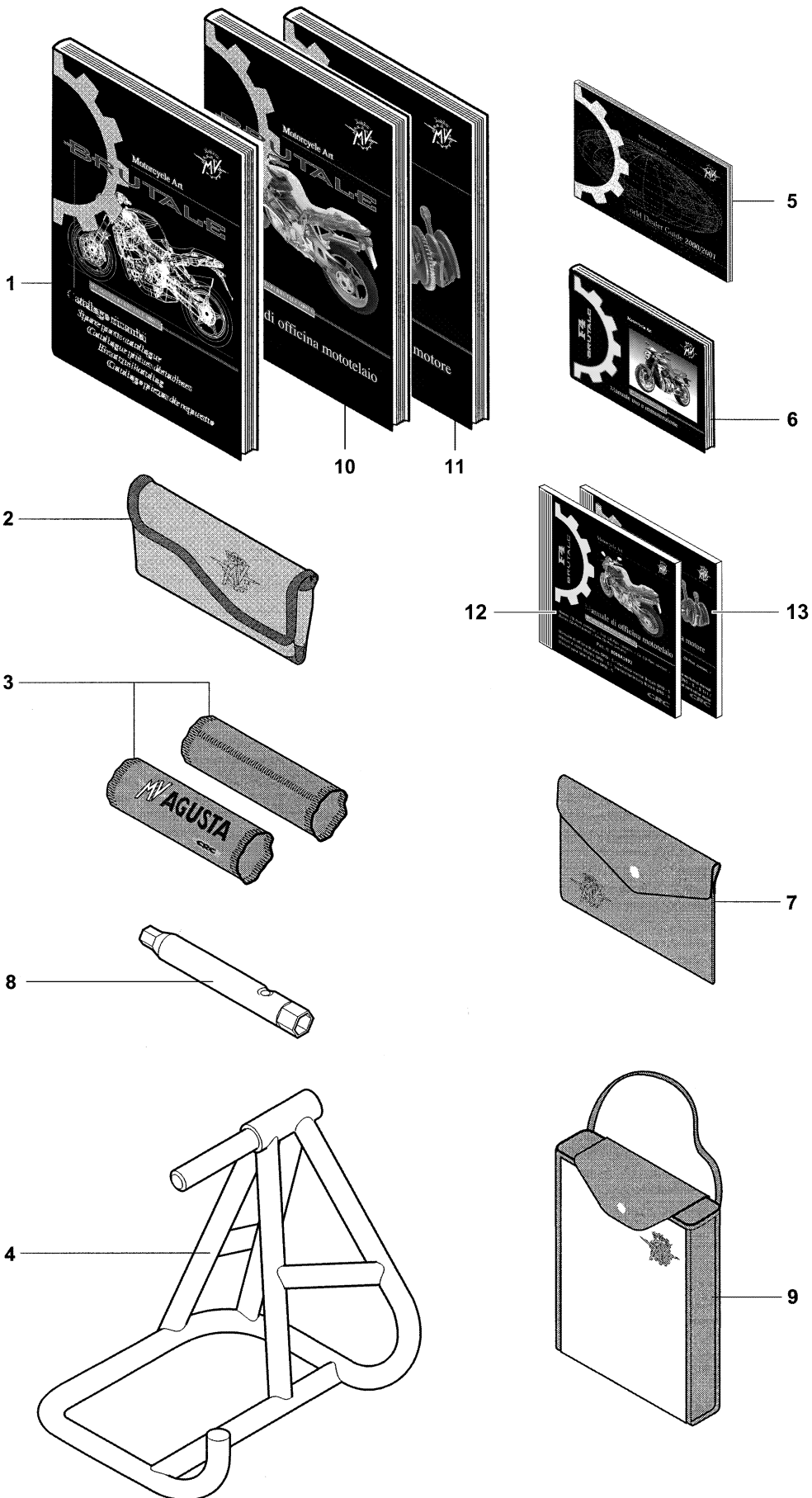



N.	Code	Q.ty	Note	BRUTALE ORO	BRUTALE S	Descrizione	Description	► I FRAME I ►	► I ENGINE I ►
1	800099359	1		•	•	Catalogo ricambi	Spare parts catalogue		
2	800099351	1		•	•	Borsa attrezzi completa	Complete tool box		
3	800094318	2		•	•	Coprimanopola	Twist grip cover		
4	800092642	1		•	•	Cavalletto posteriore	Rear stand		
5	800097886	1		•	•	World dealer guide	World dealer guide		
6	800099358	1	I	•		Libretto uso e manutenzione	Use and maintenance manual		
6	8A0099358	1	GB	•		Libretto uso e manutenzione	Use and maintenance manual		
6	8B0099358	1	F	•		Libretto uso e manutenzione	Use and maintenance manual		
6	8C0099358	1	D	•		Libretto uso e manutenzione	Use and maintenance manual		
6	8D0099358	1	E	•		Libretto uso e manutenzione	Use and maintenance manual		
6	800099361	1	USA	•		Owner's manual	Owner's manual		
6	800099358	1	I		•	Libretto uso e manutenzione	Use and maintenance manual		► I 10760
6	8A0099358	1	GB		•	Libretto uso e manutenzione	Use and maintenance manual		► I 10760
6	8B0099358	1	F		•	Libretto uso e manutenzione	Use and maintenance manual		► I 10760
6	8C0099358	1	D		•	Libretto uso e manutenzione	Use and maintenance manual		► I 10760
6	8D0099358	1	E		•	Libretto uso e manutenzione	Use and maintenance manual		► I 10760
6	800099361	1	USA		•	Owner's manual	Owner's manual		► I 10760
6	8000A4020	1	I		•	Libretto uso e manutenzione	Use and maintenance manual		10761 ►
6	8A00A4020	1	GB		•	Libretto uso e manutenzione	Use and maintenance manual		10761 ►
6	8B00A4020	1	F		•	Libretto uso e manutenzione	Use and maintenance manual		10761 ►
6	8C00A4020	1	D		•	Libretto uso e manutenzione	Use and maintenance manual		10761 ►
6	8D00A4020	1	E		•	Libretto uso e manutenzione	Use and maintenance manual		10761 ►
6	8000A4021	1	USA		•	Owner's manual	Owner's manual		10761 ►
7	800093414	1		•	•	Portadocumenti	Document holder		
8	800089013	1		•	•	Chiave candela	Spark plug spanner		
9	800099362	1		•	•	Telo coprimoto	Tarpaulin		
10	800099360	1	I	•	•	Manuale d'officina mototelaio	Service manual motor chassis		
10	8A0099360	1	GB	•	•	Manuale d'officina mototelaio	Service manual motor chassis		
10	8B0099360	1	F	•	•	Manuale d'officina mototelaio	Service manual motor chassis		
10	8C0099360	1	D	•	•	Manuale d'officina mototelaio	Service manual motor chassis		
10	8D0099360	1	E	•	•	Manuale d'officina mototelaio	Service manual motor chassis		





DOTAZIONI

OUTFIT • ÉQUIPEMENT
BORDWERKZEUG • EQUIPAMIENTO

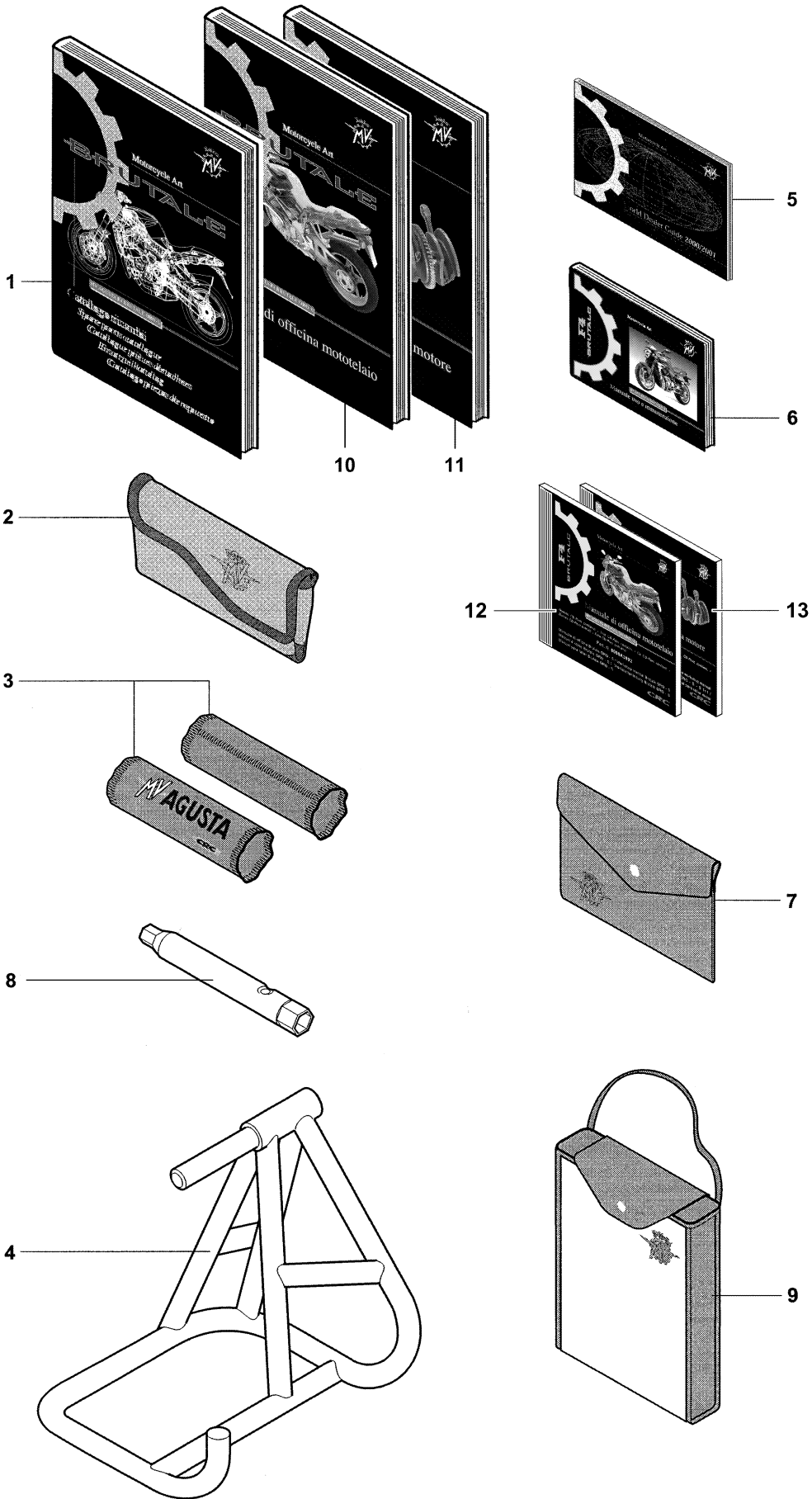

DOTAZIONI

OUTFIT • ÉQUIPEMENT

BORDWERKZEUG • EQUIPAMIENTO



N.	Code	Q.ty	Note	BRUTALE ORO	BRUTALE S	Descrizione	Description	► FRAME ►	► ENGINE ►
11	8000A1592	1	I	•	•	Manuale d'officina motore	Workshop manual		
11	8A00A1592	1	GB	•	•	Manuale d'officina motore	Workshop manual		
11	8B00A1592	1	F	•	•	Manuale d'officina motore	Workshop manual		
11	8C00A1592	1	D	•	•	Manuale d'officina motore	Workshop manual		
11	8D00A1592	1	E	•	•	Manuale d'officina motore	Workshop manual		
12	8000A6180	1		•	•	CD-Rom Manuale officina mototelaio	Service manual motor chassis CD-Rom		
13	8000A3099	1		•	•	CD-Rom Manuale officina motore	Workshop manual CD-Rom		





ATTREZZATURE DI SERVIZIO (CICLISTICA)

SERVICE TOOLS (FRAME) • MATÉRIEL (PARTIE CYCLE)

SPEZIALWERKZEUG (RAHMEN) • UTILLAJE DE SERVICIO (MOTOCICLETA)

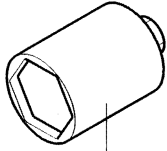

1

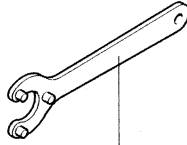

2

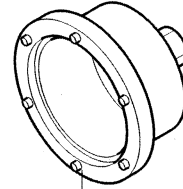

3

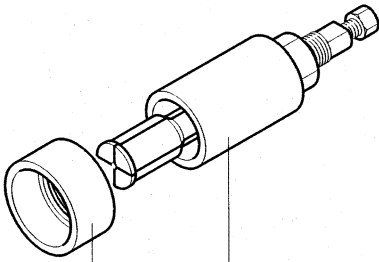

4

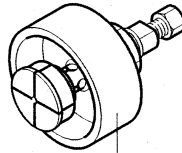

6



7

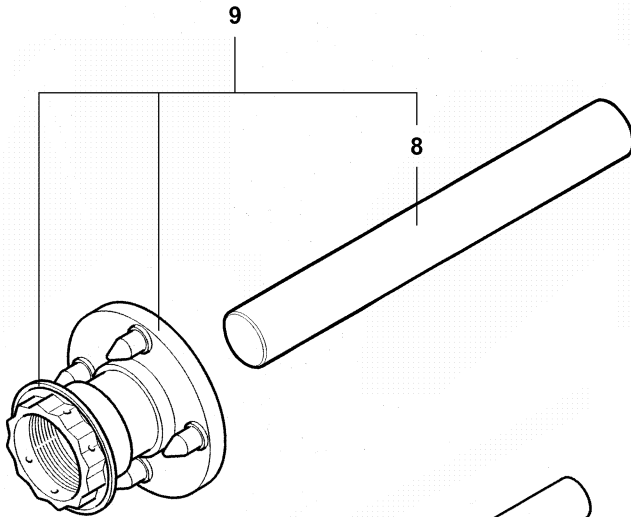

8

9

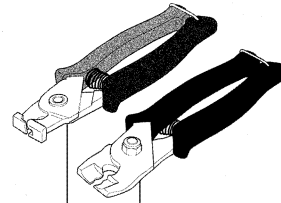

10

11

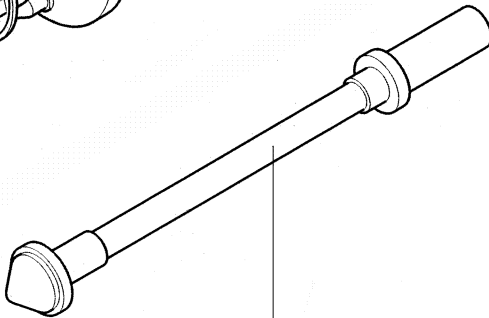

12

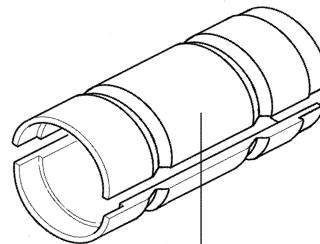

13

ATTREZZATURE DI SERVIZIO (CICLISTICA)

SERVICE TOOLS (FRAME) • MATÉRIEL (PARTIE CYCLE)

SPEZIALWERKZEUG (RAHMEN) • UTILLAJE DE SERVICIO (MOTOCICLETA)



N.	Code	Q.ty	Note	BRUTALE ORO	BRUTALE S	Descrizione	Description	► I FRAME I ►	► I ENGINE I ►
1	800092872	2		•	•	Chiave perno ruota anteriore	Front wheel spindle spanner		
2	800091645	1		•	•	Chiave ghiera cuscinetti di sterzo	Steering bearing pin wrench		
3	800092857	1		•	•	Chiave ghiera eccentrico sterzo	Steering cam ring nut wrench		
4	800092860	1		•	•	Estrattore cuscinetti forcellone	Fork bearings puller		
5	800092861	1		•	•	Boccola estrattore cuscinetti forcellone	Fork bearing puller bushing		
6	800092862	1		•	•	Estrattore cuscinetti ruota anteriore	Front wheel bearings puller		
7	800092863	1		•	•	Chiave per CPC	CPC spanner		
8	8000A1953	1		•	•	Perno per albero di centraggio	Pin for centering shaft		
9	800092865	1		•	•	Attr. bilanciamento ruota posteriore	Rear wheel balancing tool		
10	800095850	1		•	•	Pinza montaggio/smontaggio fascette clic R	Pliers for clic R clamps assembly/disassembly		
11	800098321	1		•	•	Pinza inclinata montaggio fascette clic R	Clic R clamp fitting pliers		
12	800092866	1		•	•	Attrezzo montaggio pacco forcellone	Fork pack assembly tool		
13	8000A1039	1		•	•	Attrezzo para-polvere e paraolio	Dust cover and oil splash guard tool		



ATTREZZATURE DI SERVIZIO (CICLISTICA)

SERVICE TOOLS (FRAME) • MATÉRIEL (PARTIE CYCLE)

SPEZIALWERKZEUG (RAHMEN) • UTILLAJE DE SERVICIO (MOTOCICLETA)

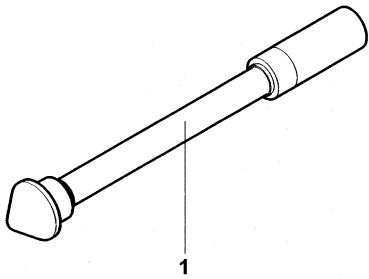

1

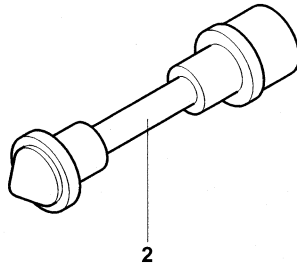

2

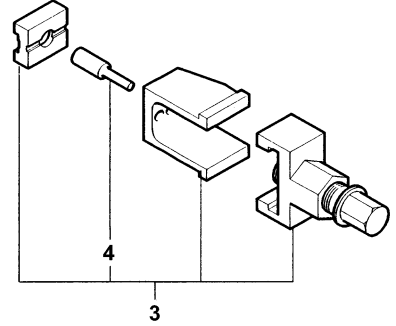

3

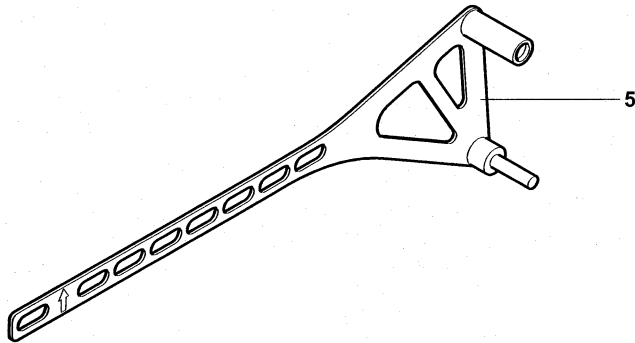

5

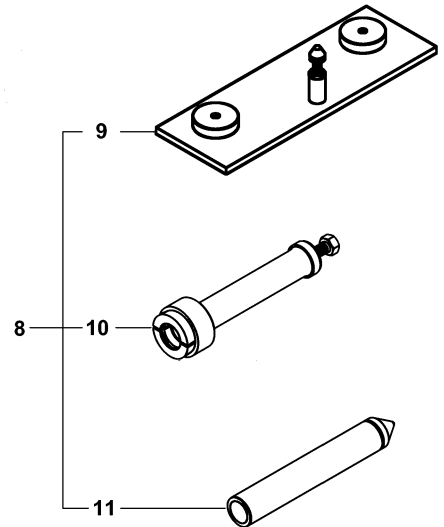

8

9

10

11

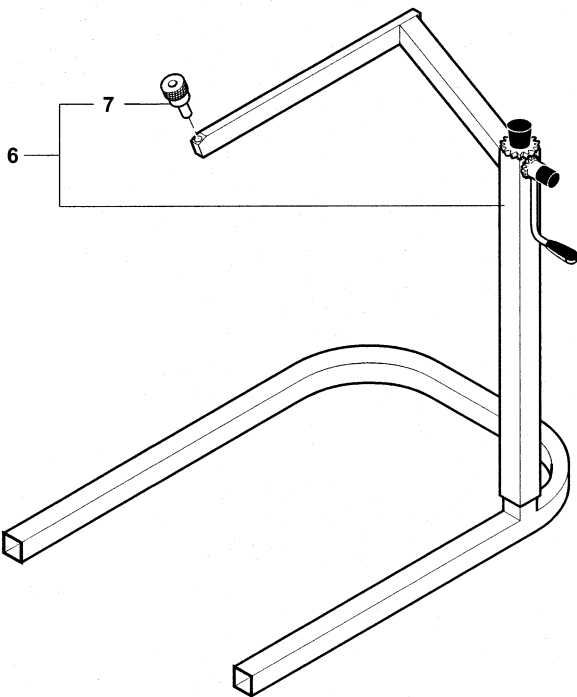

6

7

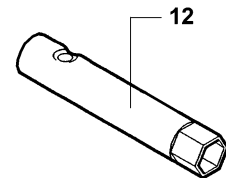

12

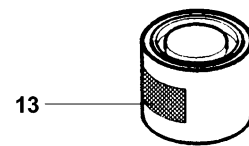

13

ATTREZZATURE DI SERVIZIO (CICLISTICA)

SERVICE TOOLS (FRAME) • MATÉRIEL (PARTIE CYCLE)

SPEZIALWERKZEUG (RAHMEN) • UTILLAJE DE SERVICIO (MOTOCICLETA)



N.	Code	Q.ty	Note	BRUTALE ORO	BRUTALE S	Descrizione	Description	► I FRAME I ►	► I ENGINE I ►
1	800092867	1		•	•	Attrezzo montaggio pacco bilanciere	Equaliser pack tool		
2	800092868	1		•	•	Attrezzo cuscinetti ruota anteriore	Front wheel bearings tool		
3	800095389	1		•	•	Attrezzo catena (passo 520:532)	Chain tool (pitch 520:532)		
4	800095390	1		•	•	Perno taglio e ribaditura (passo 520:532)	Cutting and riveting pin (pitch 520:532)		
5	800093347	1		•	•	Asta settaggio sospens. posteriore	Rear suspension setting rod		
6	800095807	1		•	•	Cavalletto anteriore	Front stand		
7	800095808	1		•	•	Perno cavalletto anteriore	Front stand pin		
8	800097887	1		•	•	Attrezzo cuscinetto perno di sterzo	Steering pin bearing tool		
9	800097888	1		•	•	Piastra di riscontro base di sterzo	Steering base plate		
10	800097889	1		•	•	Estrattore cuscinetto perno di sterzo	Steering pin bearing extractor		
11	800097890	1		•	•	Attrezzo montaggio cuscinetto perno di sterzo	Steering pin bearing assembly tool		
12	8000A1878	1		•	•	Chiave per silent-block per airbox	Airbox vibration-damper spanner		
13	800095396	1		•		Vernice "ORO MAGNESIO"	"GOLD MAGNESIUM" paint		



ATTREZZATURE DI SERVIZIO (MOTORE)

SERVICE TOOLS (ENGINE) • MATÉRIEL (MOTEUR)

SPEZIALWERKZEUG (MOTOR) • UTILLAJE DE SERVICIO (MOTOR)

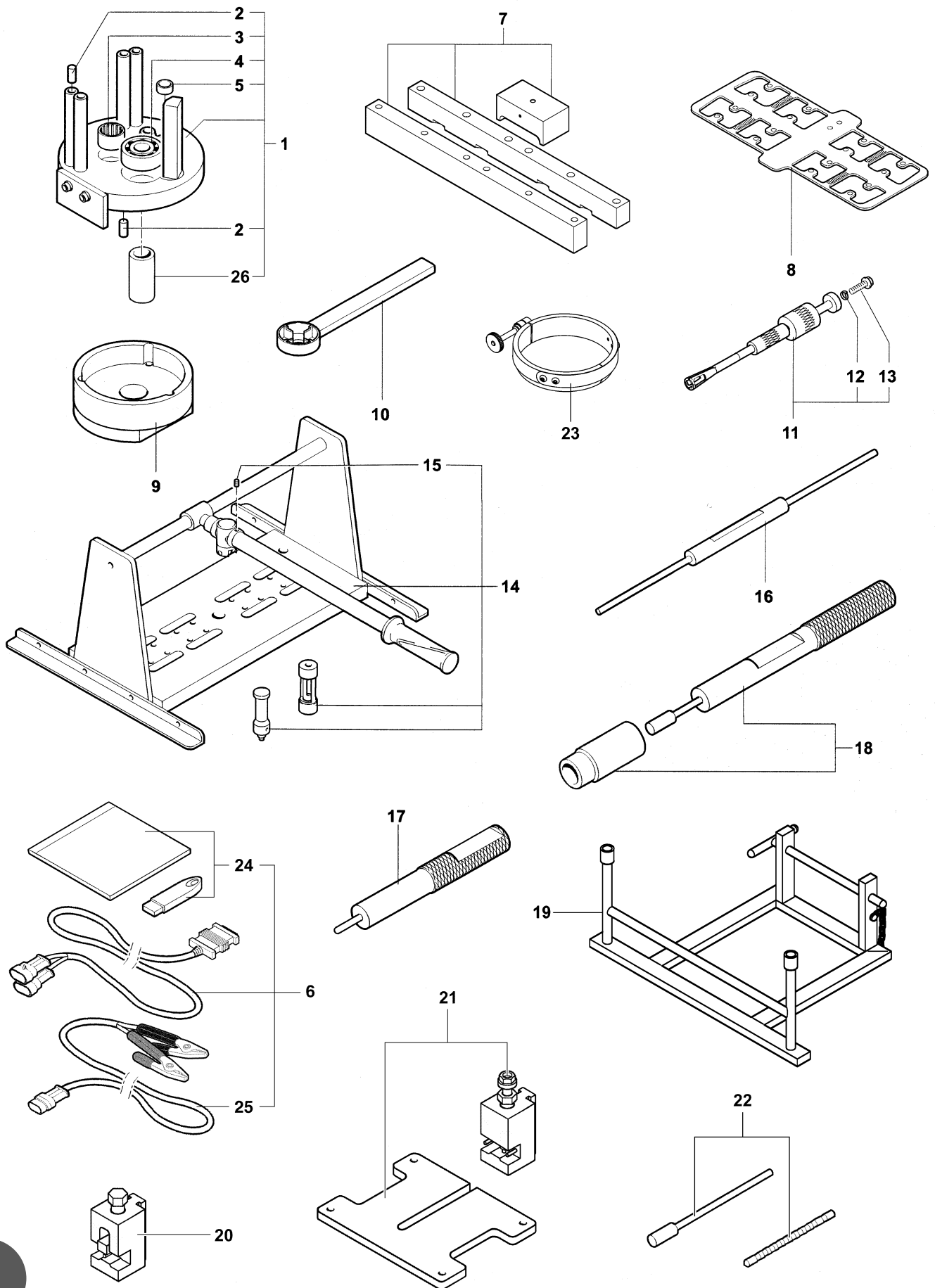

ATTREZZATURE DI SERVIZIO (MOTORE)

SERVICE TOOLS (ENGINE) • MATÉRIEL (MOTEUR)

SPEZIALWERKZEUG (MOTOR) • UTILLAJE DE SERVICIO (MOTOR)



N.	Code	Q.ty	Note	BRUTALE ORO	BRUTALE S	Descrizione	Description	► I FRAME I ►	► I ENGINE I ►
1	800094792	1		•		Attrezzo montaggio cambio	Gear change mounting tool		
1	800094792	1			•	Attrezzo montaggio cambio	Gear change mounting tool		06446 I ► ► I 09191 10410 I ► ► I 10967
1	8A0094792	1			•	Attrezzo montaggio cambio	Gear change mounting tool		09192 I ► ► I 10409 10968 I ►
2	800086119	8		•	•	Bussola di riferimento	Locating bush		
3	800081424	1		•		Cuscinetto	Bearing		
3	800081424	1			•	Cuscinetto	Bearing		06446 I ► ► I 09191 10410 I ► ► I 10967
3	8000A1087	1			•	Cuscinetto	Bearing		09192 I ► ► I 10409 10968 I ►
4	800086121	1		•		Cuscinetto	Bearing		
4	800086121	1			•	Cuscinetto	Bearing		06446 I ► ► I 09191 10410 I ► ► I 10967
4	800098405	1			•	Cuscinetto	Bearing		09192 I ► ► I 10409 10968 I ►
5	800087300	1		•	•	Cuscinetto	Bearing		
6	8000A5394	1		•	•	Software diagnostica	Diagnostics software		
7	8000A3406	1		•	•	Attrezzo misura sporgenza pistoni	Piston projection measuring tool		
8	800094797	1		•	•	Lastra sagomata copri testa	Head cover shaped plate		
9	800094795	1		•	•	Attrezzo bloccaggio rinvio albero alternatore	Alternator shaft transmission locking tool		
10	800094794	1		•	•	Attrezzo bloccaggio supporto parastrappi	Male flexible coupling support locking tool		
11	800094798	1		•	•	Attrezzo smontaggio gommini valvola	Valve rubber caps removal tool		
12	62N115538	1		•	•	Rosetta elastica	Spring washer		
13	8C0069056	3		•	•	Vite TEF M8x30	Screw M8x30		
14	800094796	1		•	•	Attrezzo montaggio/ smontaggio valvole	Valve assembly/ disassembly tool		
15	800051521	2		•	•	Vite M4x6	Screw M4x6		
16	800095429	1		•	•	Tampone controllo	Gauge pad		
17	800095581	1		•	•	Punzone montaggio tenute valvola	Valve seals mounting punch		
18	8000A2385	1		•	•	Tampone montaggio guida	Guide mounting pad		
19	800097867	1		•	•	Supporto motore	Engine support		
20	8000A2280	1		•	•	Attrezzo chiusura catena distribuz.	Timing chain mounting tool		





ATTREZZATURE DI SERVIZIO (MOTORE)

SERVICE TOOLS (ENGINE) • MATÉRIEL (MOTEUR)

SPEZIALWERKZEUG (MOTOR) • UTILLAJE DE SERVICIO (MOTOR)

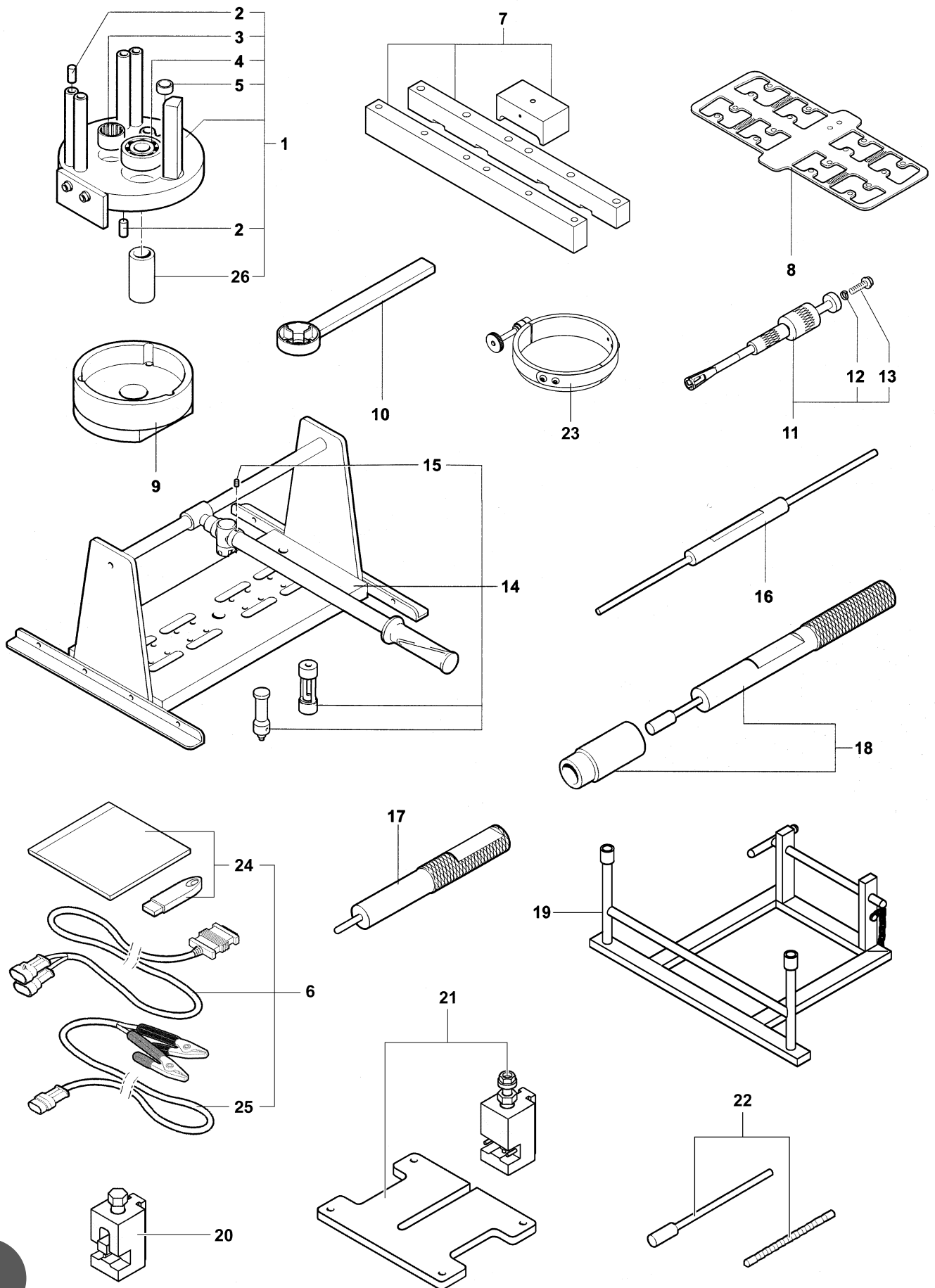

ATTREZZATURE DI SERVIZIO (MOTORE)

SERVICE TOOLS (ENGINE) • MATÉRIEL (MOTEUR)

SPEZIALWERKZEUG (MOTOR) • UTILLAJE DE SERVICIO (MOTOR)



N.	Code	Q.ty	Note	BRUTALE ORO	BRUTALE S	Descrizione	Description	► I FRAME I ►	► I ENGINE I ►
21	8000A2281	1		•	•	Attrezzo apertura catena distribuz.	Timing chain cutting tool		
22	8000A2625	1		•	•	Broccia per guida valvole	Broach for valve guide		
23	8000A1432	1		•	•	Attrezzo stringifasce per montaggio pistoni	Piston ring assembly tool		
24	8000A5353	1	❶	•	•	Aggiornamento software diagnostica	Diagnostics software update		
25	8000A5393	1	❷	•	•	Cavo interfaccia	Interface cable		
26	8000B2859	1		•		Tubo D34-d25,2-L74,5	Pipe D34-d25.2-L74.5		
26	8000B2859	1			•	Tubo D34-d25,2-L74,5	Pipe D34-d25.2-L74.5		06446 I ► ► I 09191 10410 I ► ► I 10967
26	8A00B2859	1			•	Tubo D39-d27,2-L74,5	Pipe D39-d27.2-L74.5		09192 I ► ► I 10409 10968 I ►

❶ Aggiornamento per Windows XP • Updating for Windows XP • Mise à jour pour Windows XP • Aktualisierung für Windows XP • Actualización para Windows XP.

❷ Per centralina iniezione 5SM • For 5SM injection power unit • Pour boîtier de contrôle injection 5 SM • Für Einspritz-Steuerung 5 SM • Para Centralita inyección 5 SM.

J03

3



ATTREZZATURE DI SERVIZIO (MOTORE)

SERVICE TOOLS (ENGINE) • MATÉRIEL (MOTEUR)

SPEZIALWERKZEUG (MOTOR) • UTILLAJE DE SERVICIO (MOTOR)

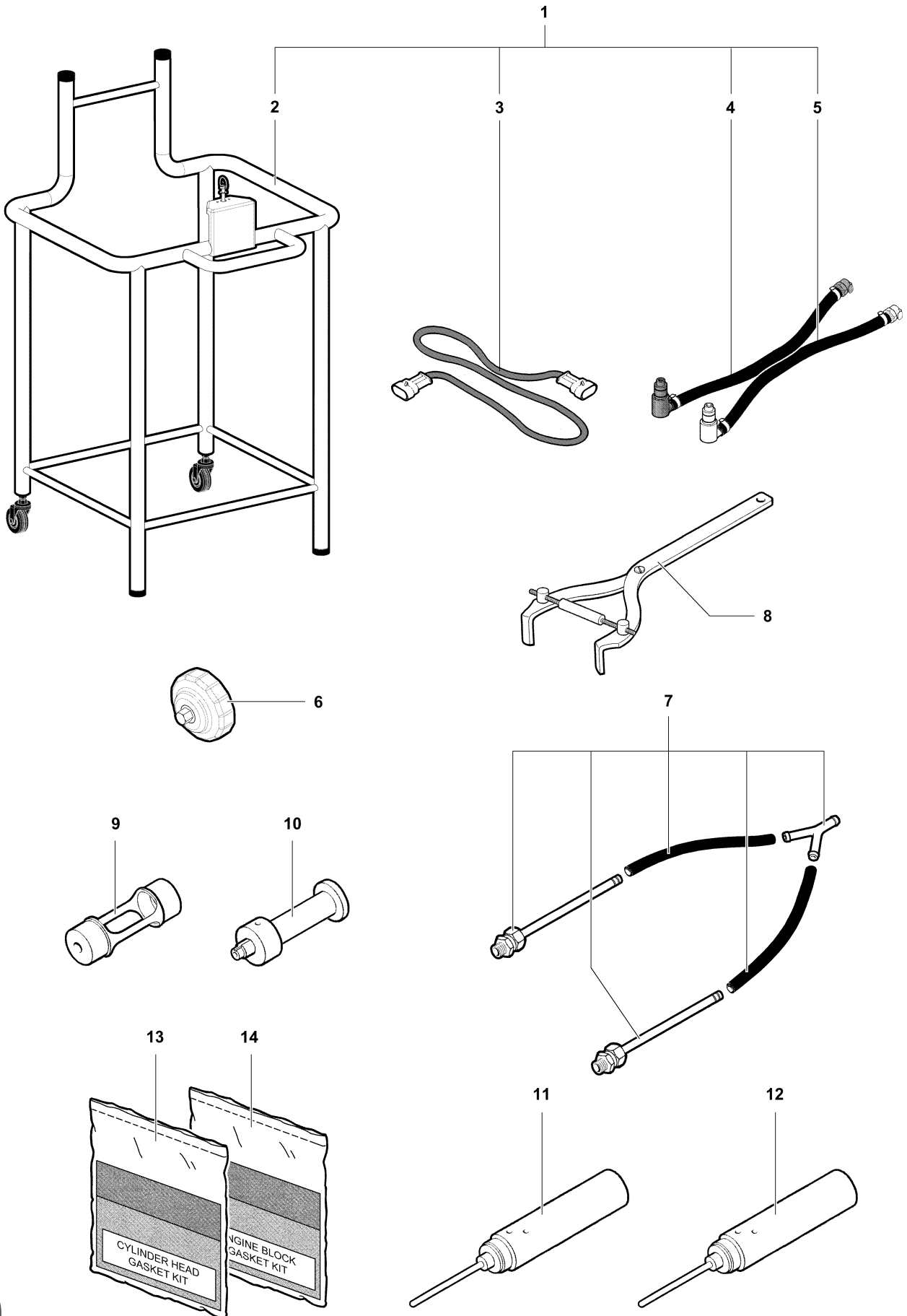

ATTREZZATURE DI SERVIZIO (MOTORE)

SERVICE TOOLS (ENGINE) • MATÉRIEL (MOTEUR)

SPEZIALWERKZEUG (MOTOR) • UTILLAJE DE SERVICIO (MOTOR)



N.	Code	Q.ty	Note	BRUTALE ORO	BRUTALE S	Descrizione	Description	► I FRAME I ►	► I ENGINE I ►
1	8000A1874	1		•	•	Attrezzatura per sostegno serbatoio benzina	Fuel tank support assembly		
2	8000A0965	1		•	•	Supporto per serbatoio benzina	Fuel tank support		
3	8000A1876	1		•	•	Cavo elettrico	Wire cable		
4	80A0A1875	1		•	•	Tubo mandata benzina completo	Fuel delivery pipe assembly		
5	8000A1875	1		•	•	Tubo ritorno benzina completo	Fuel return pipe assembly		
6	8000A4317	1		•	•	Attrezzo per filtro olio	Oil filter removal tool		
7	8000A4686	1		•	•	Attrezzatura per controllo CO	CO control tool assembly		
8	800079015	1		•	•	Attrezzo bloccaggio frizione	Clutch blocking tool		
9	800095179	1		•	•	Attrezzo smontaggio semiconi	Half-cones disassembling tool		
10	800095180	1		•	•	Attrezzo montaggio semiconi	Half-cones assembling tool		
11	800095318	1		•	•	Tampone per sede valvola scarico	Pad for exhaust valve seat		
12	800095319	1		•	•	Tampone per sede valvola aspirazione	Pad for intake valve seat		
13	8000A5018	1		•	•	Kit guarnizioni cilindro testa	Cylinder head gasket kit		
14	8000A5019	1		•	•	Kit guarnizioni cilindro basamento	Cylinder engine block gasket kit		



VARIANTI ESTERO

VERSIONS FOR FOREIGN COUNTRIES • VARIANTES ÉTRANGER
MODELLVARIANTEN AUSLAND • VARIANTES EXTRANJERO

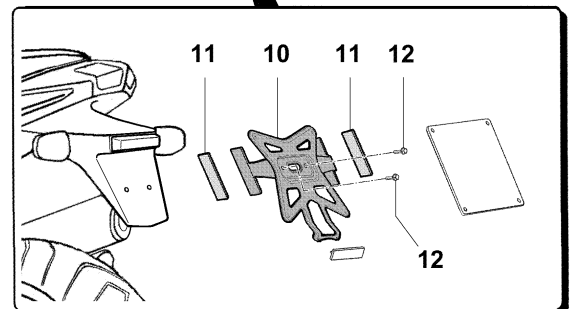
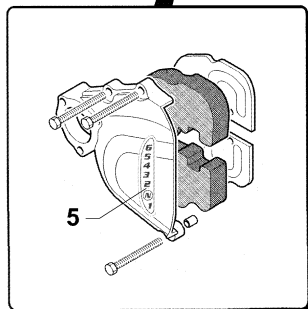
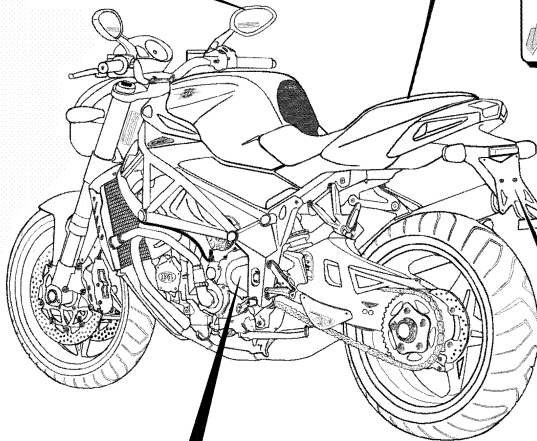
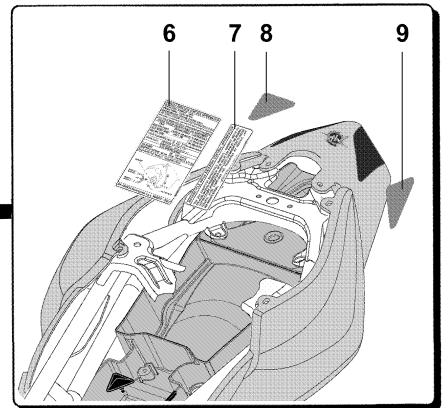
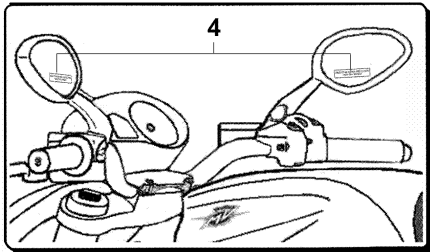
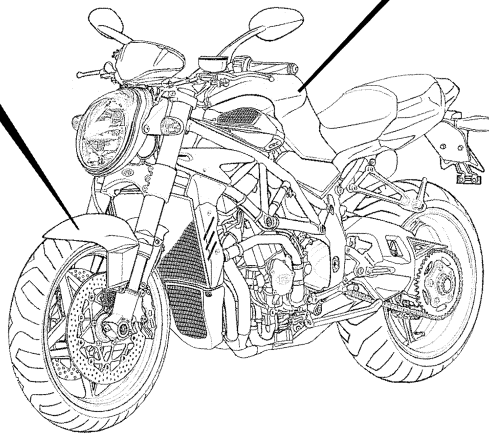
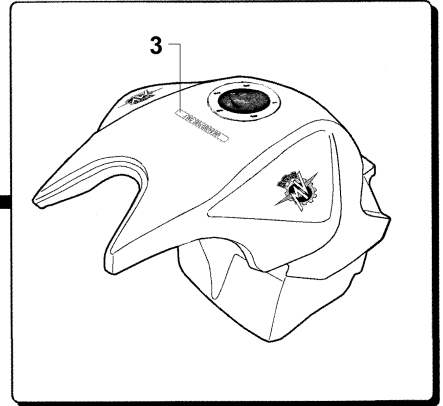
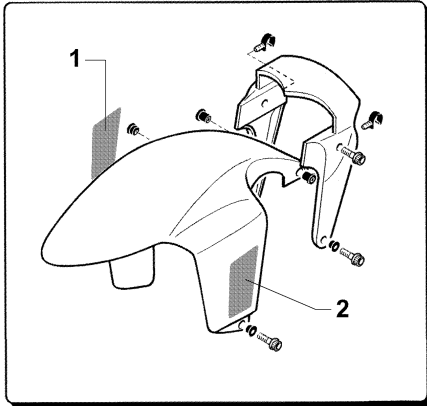

VARIANTI ESTERO

 VERSIONS FOR FOREIGN COUNTRIES • VARIANTES ÉTRANGER
 MODELLVARIANTEN AUSLAND • VARIANTES EXTRANJERO

N.	Code	Q.ty	Note	BRUTALE ORO	BRUTALE S	Descrizione	Description	► I FRAME I ►	► I ENGINE I ►
1	800095484	1	USA	•	•	Catadiottro destro per parafango ant.	Right reflector for front mudguard		
2	800095485	1	USA	•	•	Catadiottro sinistro per parafango ant.	Left reflector for front mudguard		
3	800095366	1	AUS USA	•	•	Targhetta "Benzina verde"	Decal for "Unleaded fuel"		
4	800094019	2	USA	•	•	Decal specchietto retrovisore	Decal for "Rear mirror"		
5	800095842	1	JPN	•	•	Targhetta "Ordine marce"	Decal for "The order of gear"		
6	800099378	1	USA	•	•	Targhetta "Informazioni controllo emissioni"	Decal for "Vehicle emission control information"		
7	800099379	1	USA	•	•	Targhetta "Controllo emissioni"	Decal for "Noise emission control information"		
8	800095486	1	USA	•	•	Catadiottro destro per codone	Right reflector for tail piece		
9	800095487	1	USA	•	•	Catadiottro sinistro per codone	Left reflector for tail piece		
10	8000A1825	1	AUS	•	•	Flangia portatarga/portacatadiottri	Number plate holder/retro-reflectors flange		
11	80B073832	2	AUS	•	•	Catadiottro	Retroreflector		
12	800062726	2	AUS	•	•	Vite TEF M6x14	Screw M6x14		



ASSIEME CANISTER (USA)

CARBON CANISTER ASSEMBLY (USA) • ENSEMBLE CANISTER (USA)
BAUGRUPPE CARBONKANISTER (USA) • CONJUNTO CANISTER (USA)

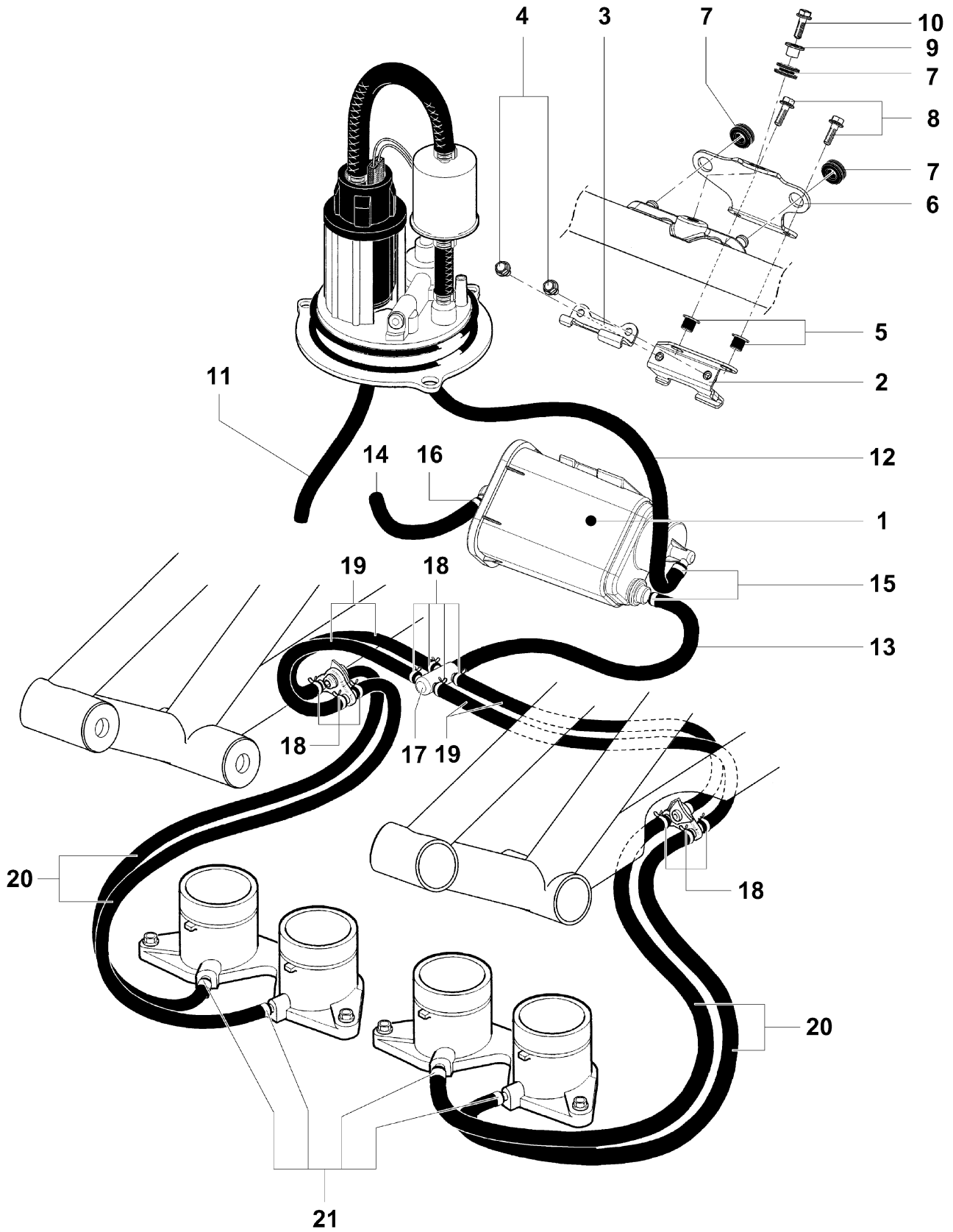

ASSIEME CANISTER (USA)CARBON CANISTER ASSEMBLY (USA) • ENSEMBLE CANISTER (USA)
BAUGRUPPE CARBONKANISTER (USA) • CONJUNTO CANISTER (USA)

N.	Code	Q.ty	Note	BRUTALE ORO	BRUTALE S	► I FRAME I ►	► I ENGINE I ►
1	800097084	1	USA	•	•		
2	8000A1681	1	USA	•	•		
3	8000A1682	1	USA	•	•		
4	8E0067997	2	USA	•	•		
5	800063150	2	USA	•	•		
6	8000A1680	1	USA	•	•		
7	800089293	3	USA	•	•		
8	8A0067997	2	USA	•	•		
9	800044099	1	USA	•	•		
10	800062727	1	USA	•	•		
11	800098950	1	USA	•	•		
12	8A0098714	1	USA	•	•		
13	8A0097089	1	USA	•	•		
14	8A0090940	1	USA	•	•		
15	800096458	2	USA	•	•		
16	8A0092256	1	USA	•	•		
17	800097088	1	USA	•	•		
18	8A0091634	12	USA	•	•		
19	800097090	4	USA	•	•		
20	8B0091037	4	USA	•	•		
21	800096458	4	USA	•	•		

**INDICE CODICI / DENOMINAZIONI**

CODEX / DESIGNATION INDEX • INDEX CODES / DÉNOMINATIONS

INHALTSVERZEICHNIS CODE • ÍNDICE CÓDIGOS / DENOMINACIONES

Code	Denominazione	Description	Désignation	Bezeichnung	Descripción	Table	N°
60N102509	VITE M6X20	SCREW M6X20	VIS M6X20	SCHRAUBE M6X20	TORNILLO M6X20	G14	13
60N102513	VITE M6X40	SCREW M6X40	VIS M6X40	SCHRAUBE M6X40	TORNILLO M6X40	G09	10
60N102520	VITE M6X75	SCREW M6X75	VIS M6X75	SCHRAUBE M6X75	TORNILLO M6X75	D03	13
						D04	3
						F01	20
60N102558	VITE M8X35	SCREW M8X35	VIS M8X35	SCHRAUBE M8X35	TORNILLO M8X35	G02	9
60N402562	VITE M8X55	SCREW M8X55	VIS M8X55	SCHRAUBE M8X55	TORNILLO M8X55	G01	56
61N115062	DADO M6	NUT M6	ECROU M6	MUTTER M6	TUERCA M6	D02	26
62N015676	ROSETTA	WASHER	RONDELLE	UNTERLEGSCHIEBE	ARANDELA	G15	20
62N015682	ROSETTA	WASHER	RONDELLE	UNTERLEGSCHIEBE	ARANDELA	G01	37
62N115538	ROSETTA ELASTICA	SPRING WASHER	RONDELLE ELASTIQUE	FEDERRING	ARANDELA ELASTICA	J03	12
62N115548	ROSETTA	WASHER	RONDELLE	UNTERLEGSCHIEBE	ARANDELA	F01	8
66N021203	ANELLO ELASTICO	SNAP RING	CIRCLIP	SPRENGRING	ARO	G06	2
66N021251	ANELLO ELASTICO	SNAP RING	CIRCLIP	SPRENGRING	ARO	G01	55
66N021272	ANELLO ELASTICO	SNAP RING	CIRCLIP	SPRENGRING	ARO	G14	12
66N021313	ANELLO ELASTICO	SNAP RING	CIRCLIP	SPRENGRING	ARO	G05	3
66N221202	ANELLO ELASTICO	SNAP RING	CIRCLIP	SPRENGRING	ARO	G07	8
66N221207	ANELLO ELASTICO	SNAP RING	CIRCLIP	SPRENGRING	ARO	G10	14
66N221210	ANELLO ELASTICO	SNAP RING	CIRCLIP	SPRENGRING	ARO	G10	14
						G10	30
66N221212	ANELLO ELASTICO	SNAP RING	CIRCLIP	SPRENGRING	ARO	G10	30
66N221262	ANELLO ELASTICO	SNAP RING	CIRCLIP	SPRENGRING	ARO	G07	6
6AN155034	SPINA ELASTICA	SPRING PIN	GOUPILLE FENDUE	SPANNSTIFT	PUA ELASTICA	D03	35
						D04	29
6AN155037	SPINA ELASTICA	SPRING PIN	GOUPILLE FENDUE	SPANNSTIFT	PUA ELASTICA	B03	18
6BN021507	SFERA D 1/4"	BALL D 1/4"	BILLE D 1/4"	KUGEL Ø 1/4"	ESFERA D 1/4"	A02	26
6BN021513	SFERA	BALL	BILLE	KUGEL	ESFERA	G01	53
800001199	ANELLO DI TENUTA	GROMMET	BAGUE D'ETANCHEITE	DICHTUNGSRING	RETEN	D02	29
800007719	BOCCOLA DI CENTRAGGIO	CENTERING BUSH	PION DE CENTRAGE	ZENTRIERBUCHSE	CASQUILLO DE CENTRAJE	G01	12
						G01	51
800017679	ANELLO DI TENUTA	GROMMET	BAGUE D'ETANCHEITE	DICHTUNGSRING	RETEN	G07	19
						G08	75
800018422	ANELLO DI TENUTA	GROMMET	BAGUE D'ETANCHEITE	DICHTUNGSRING	RETEN	G05	18
800019590	RULLINO D5X23.8	NEEDLE D5X23.8	PION D5X23.8	STIFT Ø 5X23.8	RODILLO D5X23.8	G06	6
800019789	ANELLO DI TENUTA	GROMMET	BAGUE D'ETANCHEITE	DICHTUNGSRING	RETEN	B04	16
						B05	16
800019965	ANELLO DI TENUTA	GROMMET	BAGUE D'ETANCHEITE	DICHTUNGSRING	RETEN	G13	17
800019971	RULLINO D4X15.8	NEEDLE D4X15.8	PION D4X15.8	STIFT Ø 4X15.8	RODILLO D4X15.8	G02	8
800021480	ROSETTA	WASHER	RONDELLE	UNTERLEGSCHIEBE	ARANDELA	D02	36
						D03	19
						D04	11
						G12	3
						G16	6
800022551	ANELLO DI TENUTA	GROMMET	BAGUE D'ETANCHEITE	DICHTUNGSRING	RETEN	G15	12
800023106	ANELLO DI TENUTA	GROMMET	BAGUE D'ETANCHEITE	DICHTUNGSRING	RETEN	G06	35
800023108	ANELLO DI TENUTA	GROMMET	BAGUE D'ETANCHEITE	DICHTUNGSRING	RETEN	G06	17
800023116	ANELLO DI TENUTA	GROMMET	BAGUE D'ETANCHEITE	DICHTUNGSRING	RETEN	G01	35
800028327	VITE M6X14	SCREW M6X14	VIS M6X14	SCHRAUBE M6X14	TORNILLO M6X14	G01	24
						G11	6
800029074	ANELLO DI TENUTA	GROMMET	BAGUE D'ETANCHEITE	DICHTUNGSRING	RETEN	B04	30
						B05	30
						G06	27
800031113	ROSETTA	WASHER	RONDELLE	UNTERLEGSCHIEBE	ARANDELA	B04	2
						B05	2
800031175	ANELLO DI TENUTA	GROMMET	BAGUE D'ETANCHEITE	DICHTUNGSRING	RETEN	G06	25
800033552	SPURGO	DRAIN VALVE	VIS DE PURGE	ENTLÜFTUNGSSCHRAUBE	ESPURGO	D04	10

INDICE CODICI / DENOMINAZIONI

 CODEX / DESIGNATION INDEX • INDEX CODES / DÉNOMINATIONS
 INHALTSVERZEICHNIS CODE • ÍNDICE CÓDIGOS / DENOMINACIONES

Code	Denominazione	Description	Désignation	Bezeichnung	Descripción	Table	N°
800034317	CUSCINETTO	BEARING	ROULEMENT	LAGER	COJINETE	G07	4
						G09	7
800035408	VITE M3X8	SCREW M3X8	VIS M3X8	SCHRAUBE M3X8	TORNILLO M3X8	G06	13
800035809	ANELLO DI TENUTA	GROMMET	BAGUE D'ETANCHEITE	DICHTUNGSRING	RETEN	G07	11
800036137	ROSETTA	WASHER	RONDELLE	UNTERLEGSCHIEBE	ARANDELA	G04	24
800036230	LAMPADA	BULB	AMPOULE	LAMPE	LAMPARA	F02	8
800036726	LAMPADA	BULB	AMPOULE	LAMPE	LAMPARA	F01	18
						F01	25
						F06	14
						F06	20
800037901	DADO M6	NUT M6	ECROU M6	MUTTER M6	TUERCA M6	F03	6
						F07	4
800038520	RULLINO D4X8	NEEDLE D4X8	PION D4X8	STIFT Ø 4X8	RODILLO D4X8	G06	14
						G11	19
800038624	DADO M10	NUT M10	ECROU M10	MUTTER M10	TUERCA M10	G14	9
800039335	ROSETTA	WASHER	RONDELLE	UNTERLEGSCHIEBE	ARANDELA	G15	10
800041039	ANTIVIBRANTE	VIBRATION-DAMPER	ANTI-VIBRATIONS	SCHWINGUNGSDÄMPFER	ANTIVIBRANTE	E05	26
800042022	DADO M10	NUT M10	ECROU M10	MUTTER M10	TUERCA M10	B02	16
800042023	DADO M12	NUT M12	ECROU M12	MUTTER M12	TUERCA M12	A01	13
800042278	DADO M5	NUT M5	ECROU M5	MUTTER M5	TUERCA M5	G08	3
800044099	DISTANZIALE	SPACER	ENTRETOISE	ABSTANDHALTER	DISTANCIADOR	K02	9
800044240	DADO M6	NUT M6	ECROU M6	MUTTER M6	TUERCA M6	A02	16
800047763	ROSETTA	WASHER	RONDELLE	UNTERLEGSCHIEBE	ARANDELA	G01	58
						G06	28
800048245	DADO ELASTICO M6	SPRING NUT M6	ECROU AUTOFREINE M6	ELASTISCHE MUTTER M6	TUERCA ELASTICA M6	A02	8
						B01	11
						E01	2
						E05	4
						E05	9
						E05	10
						F01	15
						F01	22
						F06	16
						F06	22
F06	27						
G08	37						
800048551	CUSCINETTO	BEARING	ROULEMENT	LAGER	COJINETE	G14	4
800050679	ANELLO DI TENUTA	GROMMET	BAGUE D'ETANCHEITE	DICHTUNGSRING	RETEN	B04	6
						B05	6
800051191	CUSCINETTO	BEARING	ROULEMENT	LAGER	COJINETE	G11	10
800051521	VITE M4X6	SCREW M4X6	VIS M4X6	SCHRAUBE M4X6	TORNILLO M4X6	J03	15
800051549	BOCCOLA	BUSH	DOUILLE	BUCHSE	CASQUILLO	G04	5
						G07	17
						G10	37
						G11	38
800053724	FASCETTA IN GOMMA	RUBBER CLAMP	COLLIER EN CAOUTCHOUC	GUMMISCHELLE	CINTA DE GOMA	F05	1
						F03	7
						F04	2
						F05	12
						F06	25
G08	78						
800056359	ROSETTA	WASHER	RONDELLE	UNTERLEGSCHIEBE	ARANDELA	A01	37
						E04	33
						F06	8
800056443	DADO M5	NUT M5	ECROU M5	MUTTER M5	TUERCA M5	E05	22
						F06	24

INDICE CODICI / DENOMINAZIONI

CODEX / DESIGNATION INDEX • INDEX CODES / DÉNOMINATIONS

INHALTSVERZEICHNIS CODE • ÍNDICE CÓDIGOS / DENOMINACIONES

Code	Denominazione	Description	Désignation	Bezeichnung	Descripción	Table	N°
800056444	FASCETTA IN NYLON	NYLON CLAMP	COLLIER EN NYLON	NYLONSCHELLE	CINTA DE NYLON	G13	25
800056783	FASCETTA IN NYLON	NYLON CLAMP	COLLIER EN NYLON	NYLONSCHELLE	CINTA DE NYLON	G08	6
800060577	VITE M6X20	SCREW M6X20	VIS M6X20	SCHRAUBE M6X20	TORNILLO M6X20	G01	57
800062651	ANTIVIBRANTE	VIBRATION-DAMPER	ANTI-VIBRATIONS	SCHWINGUNGSDÄMPFER	ANTIVIBRANTE	G08	8
						G08	30
						G08	32
800062652	BUSSOLA	BUSH	BAGUE	HÜLSE	CASQUILLO	G08	9
800062725	VITE M6X10	SCREW M6X10	VIS M6X10	SCHRAUBE M6X10	TORNILLO M6X10	D01	12
						D02	12
						E04	32
						E05	27
						G01	50
						G08	4
						G08	28
						G15	18
800062726	VITE M6X14	SCREW M6X14	VIS M6X14	SCHRAUBE M6X14	TORNILLO M6X14	A02	13
						D02	38
						G05	9
						G06	16
						G08	29
						G11	15
						G11	28
						G14	1
						K01	12
800062727	VITE M6X16	SCREW M6X16	VIS M6X16	SCHRAUBE M6X16	TORNILLO M6X16	E04	20
						F01	30
						G05	16
						G07	16
						G07	21
						K02	10
800062728	VITE M6X20	SCREW M6X20	VIS M6X20	SCHRAUBE M6X20	TORNILLO M6X20	A01	9
						D02	32
						F06	17
						G01	42
						G05	11
						G06	12
						G06	32
						G08	10
						G08	68
						G08	76
						G09	14
						G10	36
800062729	VITE M6X25	SCREW M6X25	VIS M6X25	SCHRAUBE M6X25	TORNILLO M6X25	G01	11
						G01	32
						G05	19
						G11	40
						G15	8
800062730	VITE M6X30	SCREW M6X30	VIS M6X30	SCHRAUBE M6X30	TORNILLO M6X30	G01	33
800062738	ROSETTA	WASHER	RONDELLE	UNTERLEGSCHIEBE	ARANDELA	E01	23
800063150	DADO ELASTICO M5	SPRING NUT M5	ECROU AUTOFREINE M5	ELASTISCHE MUTTER M5	TUERCA ELASTICA M5	K02	5
800064296	ANELLO DI TENUTA	GROMMET	BAGUE D'ETANCHEITE	DICHTUNGSRING	RETEN	G11	9
800064988	ROSETTA	WASHER	RONDELLE	UNTERLEGSCHIEBE	ARANDELA	G01	10
						G03	6
						G05	12
						G07	15

INDICE CODICI / DENOMINAZIONI

 CODEX / DESIGNATION INDEX • INDEX CODES / DÉNOMINATIONS
 INHALTSVERZEICHNIS CODE • ÍNDICE CÓDIGOS / DENOMINACIONES

Code	Denominazione	Description	Désignation	Bezeichnung	Descripción	Table	N°
800065814	PARAOILIO	OIL SEAL	JOINT A LEVRE	ÖHLDIHTRING	RETENEDOR DE ACEITE	G04	7
800066339	ANTIVIBRANTE	VIBRATION-DAMPER	ANTI-VIBRATIONS	SCHWINGUNGSDÄMPFER	ANTIVIBRANTE	A02	2
800067412	BUSSOLA	BUSH	BAGUE	HÜLSE	CASQUILLO	G13	2
800067545	VITE M6X50	SCREW M6X50	VIS M6X50	SCHRAUBE M6X50	TORNILLO M6X50	G09	15
800067997	VITE M5X12	SCREW M5X12	VIS M5X12	SCHRAUBE M5X12	TORNILLO M5X12	G11	44
						G15	13
800069148	PERNO PER SELLA	SADDLE PIN	AXE SELLE	SITZ WELLE	PERNO SILLIN	E05	21
800069149	ROSETTA	WASHER	RONDELLE	UNTERLEGSCHIBE	ARANDELA	E05	20
800069150	PIASTRINA SELLA	SADDLE PLATE	PLAQUETTE SELLE	SITZ BLECH	PLACA SILLIN	A02	32
800069156	ROSETTA	WASHER	RONDELLE	UNTERLEGSCHIBE	ARANDELA	G04	22
800069413	ANELLO DI TENUTA	GROMMET	BAGUE D'ETANCHEITE	DICHTUNGSRING	RETEN	G08	70
800069769	TAPPO CONICO	CONE-SHAPED PLUG	BOUCHON CONIQUE	KONISCHE GEWINDESCHRAUBE	TAPON CONOCO	G04	2
800070700	FASCETTA A MOLLA	SPRING CLAMP	COLLIER A RESSORT	FEDERSCHELLE	CINTA ELASTICA	D02	23
800070864	INTERRUTTORE STOP	STOP SWITCH	CONTACTEUR FEU STOP	BREMSLICHTSCHALTER	INTERRUPTOR DE STOP	D03	22
800070865	VITE INTERRUTTORE	SWITCH SCREW	VIS CONTACTEUR	SCHRAUBE FÜR SCHALTER	TORNILLO INTERRUPTOR	D03	23
800071007	SALTARELLO PER ROCCHETTO	SPROCKET RATCHET	CLIQUET	SPERRNOCKE FÜR KLEINRAD	MARTINETE PARA CORONA	G11	23
800071008	PUNTALE PER SALTARELLO	RATCHET PUSH ROD	POUSSOIR DE CLIQUET	METALLSPITZE FÜR SPERRNOCKE	PUNTAL PARA MARTINETE	G11	24
800071009	MOLLA	SPRING	RESSORT	FEDER	MUELLE	G11	25
800071010	NOTTOLINO DI SCORRIMENTO	SLIDING PAWL	BAGUE DE COULISSEMENT	LAUFZAHN	TRINQUETE DE DESLIZAMIENTO	G11	26
800072826	MOLLA	SPRING	RESSORT	FEDER	MUELLE	G11	35
800073529	OBLO' ISPEZIONE	OIL SIGHT GLASS	HUBLOT DE CONTROLE	SCHAUGLAS	VENTANILLA DE INSPECCION		
	LIVELLO OLIO			ÖLSTANDKONTROLLE	NIVEL DE ACEITE	G01	39
800078219	FLANGIA CORONA	GEAR FLANGE	FLASQUE	ZAHNKRANZFLANSCH	BRIDA CORONA	C01	27
800078221	VITE	SCREW	VIS	SCHRAUBE	TORNILLO	B01	31
800078224	PARASTRAPPI PER CORONA	GEAR SPRING DRIVE	FLECTEUR POUR COURONNE	REISSCHUTZ FÜR ZAHNKRANZ	ACOPLAMIENTO FLEXIBLE PARA CORONA	C01	30
800079015	ATTREZZO BLOCCAGGIO	CLUTCH BLOCKING TOOL	OUTIL POUR LE BLOCAGE	WERKZEUG FÜR DAS	UTIL PARA EL BLOQUEO		
	FRIZIONE		D'EMBRAYAGE	KUPPLUNGSBLOCKIEREN	DEL EMBRAGUE	J04	8
800080689	FILTRO OLIO (ASPIRAZIONE)	OIL FILTER (INTAKE)	FILTRE A HUILE (ADMISSION)	ÖLFILTER (ANSAUGFILTER)	FILTRO ACEITE (ASPIRACION)	G06	31
800080691	GUARNIZIONE	GASKET	JOINT	DICHTUNG	EMPAQUE	G01	40
800080695	GUARNIZIONE	GASKET	JOINT	DICHTUNG	EMPAQUE	G06	30
800080701	ALBERO POMPA OLIO	OIL PUMP SHAFT	ARBRE DE POMPE A HUILE	ÖLPUMPENWELLE	EJE BOMBA DE ACEITE	G06	7
800081164	ANELLO DI TENUTA	GROMMET	BAGUE D'ETANCHEITE	DICHTUNGSRING	RETEN	B04	17
						B05	17
800081174	DADO	NUT	ECROU	MUTTER	TUERCA	B04	14
						B05	14
800081236	ANELLO TENUTA ROTANTE	GROMMET ON REVOLVING PART	JOINT D'ETANCHEITE TOURNANT	DREHENDER DICHTUNGSRING	RETEN RODANTE	G07	10
800081237	ANELLO TENUTA FISSA	GROMMET ON FIXED PART	JOINT D'ETANCHEITE FIXE	FESTER DICHTUNGSRING	RETEN FIJO	G07	22
800081239	DISTANZIALE	SPACER	ENTRETOISE	ABSTANDHALTER	DISTANCIADOR	G07	5
800081261	PERNO RINVIO	TIMING TRANSMISSION	AXE RENVOI	VORGELEGEWELLE	PERNO REENVIO		
	DISTRIBUZIONE	PIN	DISTRIBUTION	VENTILSTEUERUNG	DISTRIBUCION	G05	2
800081280	MANICOTTO	PUMP/MANIFOLD SLEEVE	MANCHON	VERBINDUNGSSTUTZEN	MANGUITO ACOPLAMIENTO		
	POMPA/COLLETORE		POMPE/COLLECTEUR	PUMPE/KOLLEKTOR	BOMBA/COLECTOR	G08	72
800081283	TERMOSTATO	THERMOSTAT	THERMOSTAT	THERMOSTAT	TERMOSTATO	G08	69
800081304	ANELLO DI TENUTA	GROMMET	BAGUE D'ETANCHEITE	DICHTUNGSRING	RETEN	G13	12
800081315	SEMICUSCINETTO	BIG END HALF	DEMI-COUSSINET	PLEUEL-	SEMICOJINETE		
	DI BIELLA (ROSSO)	BEARING (RED)	DE BIELLE (ROUGE)	LAGERSCHALENHÄLFTE (ROT)	DE BIELLA (ROJO)	G02	5
800081316	SEMICUSCINETTO DI	CRANKSHAFT	HALF DEMI-COUSSINET	KURBELWELLEN-	SEMICOJINETE		
	BANCO (ROSSO)	BEARING (RED)	DE PALIER (ROUGE)	LAGERSCHALENHÄLFTE (ROT)	PRINCIPAL (ROJO)	G01	17
800081317	SEMICUSCINETTO DI	CRANKSHAFT HALF	DEMI-COUSSINET	KURBELWELLEN-	SEMICOJINETE		
	BANCO (ROSSO)	BEARING (RED)	DE PALIER (ROUGE)	LAGERSCHALENHÄLFTE (ROT)	PRINCIPAL (ROJO)	G01	16
800081357	INGRANAGGIO POMPA OLIO	OIL PUMP GEAR	PIGNON DE POMPE A HUILE	ÖLPUMPENZAHNRAD	ENGRANAJE BOMBA DE ACEITE	G06	3
800081362	ROTORE ESTERNO	OIL PUMP OUTER ROTOR	ROTOR EXTERIEUR	ÄUSSERER	ROTOR ESTERNO		
	POMPA OLIO		POMPE A HUILE	ÖLPUMPENROTOR	BOMBA DE ACEITE	G06	9
800081363	ROTORE INTERNO	OIL PUMP INNER ROTOR	ROTOR INTERIEUR	INNERER	ROTOR INTERNO		
	POMPA OLIO		POMPE A HUILE	ÖLPUMPENROTOR	BOMBA DE ACEITE	G06	8

INDICE CODICI / DENOMINAZIONI

CODEX / DESIGNATION INDEX • INDEX CODES / DÉNOMINATIONS

INHALTSVERZEICHNIS CODE • ÍNDICE CÓDIGOS / DENOMINACIONES

Code	Denominazione	Description	Désignation	Bezeichnung	Descripción	Table	N°
800081364	ROTORE ESTERNO POMPA OLIO	OIL PUMP OUTER ROTOR	ROTOR EXTERIEUR POMPE A HUILE	ÄUSSERER ÖLPUMPENROTOR	ROTOR EXTERNO BOMBA DE ACEITE	G06	4
800081365	ROTORE INTERNO POMPA OLIO	OIL PUMP INNER ROTOR	ROTOR INTERIEUR POMPE A HUILE	INNERER ÖLPUMPENROTOR	ROTOR INTERNO BOMBA DE ACEITE	G06	5
800081380	PERNO	PIN	AXE	WELLE	PERNO	G14	15
800081381	PIASTRINA	PLATE	PLAQUETTE	BLECH	PLACA	G14	16
800081388	MOTORINO AVVIAMENTO	STARTER	DEMARREUR	ANLASSERMOTOR	MOTOR DE ARRANQUE	G15	6
800081393	VITE FISSAGGIO SUPPORTO	SUPPORT CLAMP SCREW	VIS DE FIXATION SUPPORT	BEFESTIGUNGSSCHRAUBE HALTERUNG	TORNILLO FIJACION SOPORTE	G14	7
800081402	PERNO COMANDO FRIZIONE	CLUTCH CONTROL PIN	POUSSOIR DE DEBRAYAGE	KUPPLUNGSSZAPFEN	PERNO ACCIONAMIENTO EMBRAGUE	G09	11
800081403	VALVOLA	VALVE	VALVE	VENTIL	VALVULA	G01	36
800081409	RACCORDO FILTRO OLIO	OIL FILTER UNION	RACCORD FILTRE A HUILE	ANSCHLUSS ÖLFILTER	RACOR FILTRO ACEITE	G06	21
800081412	TAPPO DI CHIUSURA	PLUG	BOUCHON	VERSCHLUSS	TAPON	G01	15
800081413	PIASTRINA	PLATE	PLAQUETTE	BLECH	PLACA	G01	27
800081418	PRIGIONIERO	STUD BOLT	GOIJON	STIFTSCHRAUBE	ESPARRAGO	G01	28
800081419	PRIGIONIERO	STUD BOLT	GOIJON	STIFTSCHRAUBE E	SPARRAGO	G01	29
800081422	CUSCINETTO	BEARING	ROULEMENT	LAGER	COJINETE	G01	22
800081424	CUSCINETTO	BEARING	ROULEMENT	LAGER	COJINETE	G01 J03	30 3
800081443	PIATTELLO DI CONTENIMENTO	HOLDING CAP	FLASQUE	RÜCKHALTEBLECH	CAZOLETA DE RETENCION	G06	10
800081445	SUPPORTO PARASTRAPPI	SPRING DRIVE SUPPORT	SUPPORT FLECTEUR	REISSCHUTZHALTERUNG	SOPORTE EMBRAGUE DE SEGURIDAD	G14	5
800081451	ROSETTA DI SICUREZZA	SAFETY WASHER	RONDELLE DE SURETE	SICHERUNGSSCHEIBE	ARANDELA DE SEGURIDAD	G09 G10	2 33
800081453	ANELLO DI TENUTA	GROMMET	BAGUE D'ETANCHEITE	DICHTUNGSRING	RETEN	G14	11
800081461	FLANGIA ALTERNATORE	ALTERNATOR FLANGE	STATOR	LICHTMASCHINENFLANSCH	BRIDA ALTERNADOR	G14	10
800081508	PIATTO SPINGIDISCHI	DISK THRUST PLATE	PLATEAU DE PRESSION	DRUCKTELLER	PLATO DE PRESION	G09	6
800081510	DISCO CONDOTTO LISCIO	PLAIN DRIVEN PLATE	DISQUE LISSE GLATTE	GEFÜHRTE SCHEIBE	DISCO CONDUCCO LISO	G09	5
800081511	DISCO FRIZIONE GUARNITO	LINED CLUTCH DISK	DISQUE GARNI	KUPPLUNGSSCHEIBE MIT BELAG	DISCO EMBRAGUE CON JUNTA	G09	4
800081516	MOLLA	SPRING	RESSORT	FEDER	MUELLE	G09	8
800081517	ROSETTA	WASHER	RONDELLE	UNTERLEGSCHIEBE	ARANDELA	G09	18
800081519	BUSSOLA	BUSH	BAGUE	HÜLSE	BUJE	G09	9
800081535	BOCCOLA	BUSH	DOUILLE	BUCHSE	BUJE	G03	7
800081536	VITE M6X1	SCREW M6X1	VIS M6X1	SCHRAUBE M6X1	TORNILLO M6X1	G03 G07	5 14
800081538	GIRANTE	ROTOR	ROTOR	PUMPENRAD	RODETE	G07	7
800081539	ALBERO GIRANTE	ROTOR SHAFT	ARBRE DU ROTOR	PUMPENRADWELLE EJE	RODETE	G07	9
800081547	DADO FISSAGGIO TESTA	HEAD STOP NUT	ECROU DE FIXATION CULASSE	MUTTER ZYLINDERKOPFBEFESTIGUNG	TUERCA FIJACION CULATA	G04	21
800081552	PATTINO FISSO	FIXED GUIDE SHOE	PATIN FIXE	FESTE KETTENFÜHRUNG	PATIN FIJO	G05	10
800081583	FORCELLA INNESTO MARCE	SHIFTING FORK	FOURCHETTE DE SELECTION	SCHALTGABEL	HORQUILLA ENGRANE MARCHA	G11	16
800081585	PERNO PER FORCELLA	FORK PIN	AXE DE FOURCHETTE	SCHALTGABELWELLE	PERNO PARA HORQUILLA	G11	18
800081590	PIASTRINA	PLATE	PLAQUETTE	BLECH	PLACA	G11	27
800082695	PERNO	PIN	AXE	ZAPFEN	PERNO	D03 D04	33 27
800082708	VITE PIEDINO FORCELLA	FORK FOOT SCREW	VIS PIED DE FOURCHE	SCHRAUBE GABELFUSS	TORNILLO PATA HORQUILLA	B04 B05	3 3
800082728	TAPPO	PLUG	BOUCHON	VERSCHLUSS	TAPON	D03	26
800082743	PERNO RITENUTA PASTIGLIE	PAD STOP PIN	AXE DE MAINTIEN DES PLAQUETTES	RÜCKHALTEBOLZEN BREMSBELÄGE	PERNO RETENCION PASTILLAS	C01 C02	23 12
800082746	MOLLA RITEGNO PASTIGLIE	PAD CHECK SPRING	PLAQUETTE D'APPUI	RÜCKHALTEFEDER BREMSBELÄGE	MUELLE RETENCION PASTILLAS	C01	22

INDICE CODICI / DENOMINAZIONI

 CODEX / DESIGNATION INDEX • INDEX CODES / DÉNOMINATIONS
 INHALTSVERZEICHNIS CODE • ÍNDICE CÓDIGOS / DENOMINACIONES

Code	Denominazione	Description	Désignation	Bezeichnung	Descripción	Table	N°
800082748	COPPIA PASTIGLIE FRENO POSTERIORE	REAR BRAKE PADS	PAIRE DE PLAQUETTES FREIN ARRIÈRE	BREMSBELAGPAAR HINTERRADBREMSE	PAR DE PASTILLAS DE FRENO	C01	21
800082750	GHIERA PERNO RUOTA ANTERIORE	FRONT WHEEL PIN RING NUT	ECROU AXE DE ROUE AVANT	NUTMUTER VORDERRADACHSE	VIOLA PERNO RUEDA DELANTERA	C02	8
800082752	PERNO RUOTA ANTERIORE	FRONT WHEEL PIN	AXE DE ROUE AVANT	VORDERRADACHSE	PERNO RUEDA DELANTERA	C02	7
800082753	PINZA FRENO POSTERIORE	REAR BRAKE CALIPER	ETRIER FREIN ARRIÈRE	BREMSSATTEL HINTERRADBREMSE	PINZA FRENO TRASERO	C01	20
800082758	DISCO FRENO ANTERIORE	FRONT BRAKE DISK	DISQUE FREIN AVANT	BREMSSCHEIBE VORDERRADBREMSE	DISCO FRENO DELANTERO	C02	5
800082760	DISCO FRENO POSTERIORE	REAR BRAKE DISK	DISQUE FREIN ARRIÈRE	BREMSSCHEIBE HINTERRADBREMSE	DISCO FRENO TRASERO	C01	11
800082761	PIASTRA PORTAPINZA	CALIPER PLATE	SUPPORT D'ETRIER	BREMSSATTELHALTER	PLACA PORTAPINZA	C01	14
800084182	PASTIGLIA REGOLAZIONE GIOCO (SP.1.60)	CLEARANCE ADJUSTING PAD (THICKNESS 1.60)	PASTILLE DE CALAGE (SP.1.60)	EINSTELLPLÄTTCHEN VENTILSPIEL (STÄRKE 1.60)	PASTILLA REGULACION JUEGO (SP.1.60)	G05	21
800084858	DISTANZIALE	SPACER	ENTRETOISE	ABSTANDHALTER	DISTANCIADOR	B02	13
800084859	BUSSOLA SX FORCELLONE	FORK LH BUSH	DOUILLE G. BRAS OSCILLANT	LINKE SCHWINGENBUCHSE	CASQUILLO IZQUIERDA HORQUILLA	B01	8
800084863	VITE PER BILANCIERE	EQUALIZER SCREW	VIS DE BALANCIER	SCHRAUBE FÜR HINTERRADSWINGE	TORNILLO PARA BALANCIN	B02	15
800084865	VITE INF. FISSAGGIO MOTORE	ENGINE LOWER CLAMP SCREW	VIS INF. ANCRAGE MOTEUR	UNTERE MOTOR- BEFESTIGUNGSSCHRAUBE	TORNILLO INFERIOR FIJACION MOTOR	A01	12
800084866	VITE SUP. FISSAGGIO MOTORE	ENGINE UPPER CLAMP SCREW	VIS SUP. ANCRAGE MOTEUR	OBERE MOTOR- BEFESTIGUNGSSCHRAUBE	TORNILLO SUPERIOR FIJACION MOTOR	A01	11
800084867	VITE M12X30	SCREW M12X30	VIS M12X30	SCHRAUBE M12X30	TORNILLO M12X30	A01	14
800084868	VITE INF. BIELLA SOSPENSIONE	SUSPENSION SUPPORT LOWER SCREW	VIS INF. BIELLETTE DE SUSPENSION	UNTERE SCHRAUBE AUFHÄNGUNGS-SCHUBSTANGE	TORNILLO INF. BIELLA SUSPENSION	B02	6
800084869	VITE ANT. FISSAGGIO MOTORE	ENGINE FRONT CLAMP SCREW	VIS AV. ANCRAGE MOTEUR	VORDERE MOTOR- BEFESTIGUNGSSCHRAUBE	TORNILLO DELANTERO FIJACION MOTOR	A01	3
800084871	PIASTRINA	PLATE	PLAQUETTE	BLECH	PLACA	A01	2
800084872	DISTANZIALE	SPACER	ENTRETOISE	ABSTANDHALTER	DISTANCIADOR	B01	2
800084873	BUSSOLA DX FORCELLONE	FORK RH BUSH	BAGUE D. BRAS OSCILLANT	RECHTE SCHWINGENBUCHSE	CASQUILLO DER. HORQUILLA	B01	9
800084874	BUSSOLA	BUSH	BAGUE	HÜLSE	CASQUILLO	B02	5
800084875	REGISTRO	REGISTER	ECROU DE REGLAGE	EINSTELLVORRICHTUNG	REGULADOR	B02	3
800084889	VITE DISCO FRENO POSTERIORE	REAR BRAKE DISK SCREW	VIS DISQUE FREIN ARRIÈRE	SCHRAUBE BREMSSCHEIBE HINTERRADBREMSE	TORNILLO DISCO FRENO TRASERO	C01	12
800084890	FLANGIA DISCO FRENO POSTERIORE	REAR BRAKE DISK FLANGE	FLASQUE DISQUE FREIN ARRIÈRE	BREMSSCHEIBENFLANSCH HINTERRADBREMSE	BRIDA DISCO FRENO TRASERO	C01	9
800084891	DADO M7	NUT M7	ECROU M7	MUTTER M7	TUERCA M7	C01	13
800084893	ROSETTA	WASHER	RONDELLE	UNTERLEGSCHLEIBE	ARANDELA	C01	16
800084894	ROSETTA	WASHER	RONDELLE	UNTERLEGSCHLEIBE	ARANDELA	C01	32
800084896	DISTANZIALE	SPACER	ENTRETOISE	ABSTANDHALTER	DISTANCIADOR	C01	31
800084898	FERMAGLIO	CLIP	JONC	KLEMMRING	BROCHE	C01	19
800084899	FERMAGLIO	CLIP	JONC	KLEMMRING	BROCHE	C01	34
800084901	SPINA	PIN	GOIJON	STIFT	PERNO	C01	8
800084902	VITE PER SPINA	PIN SCREW	VIS	SCHRAUBE FÜR STIFT	TORNILLO PARA PERNO	C01	10
800084903	DADO DX RUOTA POST.	REAR WHEEL RH NUT	ECROU D. ROUE ARRIERE	RECHTE MUTTER HINTERRAD	TUERCA DER. RUEDA TRASERA	C01	33
800084904	DADO SX RUOTA POST.	REAR WHEEL LH NUT	ECROU G. ROUE ARRIERE	LINKE MUTTER HINTERRAD	TUERCA IZQ. RUEDA TRASERA	C01	18
800084909	ANELLO DI TENUTA	GROMMET	BAGUE D'ETANCHEITE	DICHTUNGSRING	RETEN	C01	5
800084913	ANELLO ELASTICO	SNAP RING	CIRCLIP	SPRENGRING	ARO	C01	17
800084914	DISTANZIALE	PACER	ENTRETOISE	ABSTANDHALTER	DISTANCIADOR	C01	6
800084915	VITE DI FASATURA	TIMING SCREW	VIS DE CALAGE	SCHRAUBE PHASENAUSRICHTUNG	TORNILLO PARA FASE	A01	21
800084936	CUSCINETTO	BEARING	ROULEMENT	LAGER	COJINETE	B01	5
800084937	ANELLO DI TENUTA	GROMMET	BAGUE D'ETANCHEITE	DICHTUNGSRING	RETEN	B01	6
800084938	CUSCINETTO	BEARING	ROULEMENT	LAGER	COJINETE	B01	3

INDICE CODICI / DENOMINAZIONI

 CODEX / DESIGNATION INDEX • INDEX CODES / DÉNOMINATIONS
 INHALTSVERZEICHNIS CODE • ÍNDICE CÓDIGOS / DENOMINACIONES

Code	Denominazione	Description	Désignation	Bezeichnung	Descripción	Table	N°
800084939	ANELLO ELASTICO	SNAP RING	CIRCLIP	SPRENGRING	ARO	B01	4
800084945	CUSCINETTO	BEARING	ROULEMENT	LAGER	COJINETE	B02	11
800084946	ANELLO DI TENUTA	GROMMET	BAGUE D'ETANCHEITE	DICHTUNGSRING	RETEN	B02	12
800084952	DADO M10	NUT M10	ECROU M10	MUTTER M10	TUERCA M10	C01	29
800085071	VITE M6X35	SCREW M6X35	VIS M6X35	SCHRAUBE M6X35	TORNILLO M6X35	G04	6
800085493	BUSSOLA	BUSH	BAGUE	HÜLSE	CASQUILLO	G11	32
800085495	SALTARELLO FISSA MARCE	GEARS STOP RATCHET	DOIGT DE VERROUILLAGE	SPERRNOCKE GANGWAHL	TRIQUETE FIJACION MARCHAS	G11	29
800086107	ROSETTA	WASHER	RONDELLE	UNTERLEGSCHIEBE	ARANDELA	G11	31
800086114	PIASTRA	PLATE	PLAQUE	PLATTE	PLACA	G11	5
800086116	CUSCINETTO	BEARING	ROULEMENT	LAGER	COJINETE	G11	4
800086117	GUARNIZIONE	GASKET	JOINT	DICHTUNG	EMPAQUE	G11	2
800086119	BOCCOLA DI RIFERIMENTO	DOWEL BUSH	PION DE CENTRAGE	ZENTRIERBUCHSE	BOCCOLA DI RIFERIMENTO	G01	14
						J03	2
800086121	CUSCINETTO	BEARING	ROULEMENT	LAGER	COJINETE	J03	4
800086131	BOCCOLA	BUSH	PION	BUCHSE	BUJE	G11	47
800086132	VALVOLA REGOLAZ. PRESSIONE	PRESSURE ADJUSTING VALVE	SOUPAPE REGULATRICE DE PRESSION	VENTIL DRUCKEINSTELLUNG	VALVULA REGULACION PRESION	G06	29
800086201	POMPA OLIO COMPLETA	OIL PUMP ASSEMBLY	POMPE A HUILE COMPLETE	ÖLPUMPE KOMPLETT	BOMBA DE ACEITE COMPLETA	G06	1
800086208	BUSSOLA	BUSH	BAGUE	HÜLSE	CASQUILLO	G14	2
800086223	ANELLO DI TENUTA	GROMMET	BAGUE D'ETANCHEITE	DICHTUNGSRING	RETEN	G15	2
800086395	VITE M15X22	SCREW M15X22	VIS M15X22	SCHRAUBE M15X22	TORNILLO M15X22	B01	35
800086396	ROSETTA	WASHER	RONDELLE	UNTERLEGSCHIEBE	ARANDELA	B01	34
800086436	GHIERA	RING NUT	ECROU	GEWINDERING	VIROLA	B03	10
800086446	DISTANZIALE	SPACER	ENTRETOISE	ABSTANDHALTER	DISTANCIADOR	B01	32
800086447	BUSSOLA	BUSH	BAGUE	HÜLSE	CASQUILLO	B02	14
800086500	ANELLO DI TENUTA	GROMMET	BAGUE D'ETANCHEITE	DICHTUNGSRING	RETEN	B04	11
						B05	11
800086503	BOCCOLA	BUSH	BAGUE	HÜLSE	CASQUILLO	B04	13
						B05	13
800086699	BUSSOLA	BUSH	BAGUE	HÜLSE	CASQUILLO	G10	3
800086702	ANELLO DI TENUTA	GROMMET	BAGUE D'ETANCHEITE	DICHTUNGSRING	RETEN	C01	15
						G07	13
800086726	RUOTA FONICA	PHONIC WHEEL	ROUE PHONIQUE	SENSOR RADDREHUNG	RUEDA FONICA	G02	7
800086727	DADO FISSAGGIO RUOTA FONICA	PHONIC WHEEL STOP NUT	ECROU ANCRAGE ROUE PHONIQUE	BEFESTIGUNGSMUTTER SENSOR RADDREHUNG	TUERCA FIJACION RUEDA FONICA	G02	6
800086732	FLANGIA RITEGNO RUOTA LIBERA	FREEWHEEL CHECK FLANGE	FLASQUE DE MAINTIEN ROUE LIBRE	RÜCKHALTEFLANSCH FREILAUF	BRIDA RETENCION RUEDA LIBRE	G14	18
800086735	PATTINO MOBILE	MOVABLE PAD	PATIN MOBILE	BEWEGLICHE KETTENFÜHRUNG	PATIN MOVIL	G05	13
800086737	ROSETTA	WASHER	RONDELLE	UNTERLEGSCHIEBE	ARANDELA	G01	23
800087124	INTERRUTTORE SPIA FOLLE	NEUTRAL PILOT LIGHT SWITCH	CONTACTEUR VOYANT POINT MORT	SCHALTER INTERRUPTOR LEERLAUFKONTROLLE	LUZ TESTIGO NEUTRO	G15	9
800087288	INGRANAGGIO RUOTA LIBERA	FREEWHEEL GEAR	PIGNON ROUE LIBRE	ZAHNRAD FREILAUF	ENGRANAJE RUEDA LIBRE	G14	3
800087289	RUOTA LIBERA	FREEWHEEL	ROUE LIBRE	FREILAUF	RUEDA LIBRE	G14	17
800087290	SUPPORTO PARASTRAPPI	SPRING DRIVE SUPPORT	SUPPORT DE FLECTEUR	HALTERUNG REISSSCHUTZ	SOPORTE ACOPLAMIENTO FLEXIBLE	G14	6
800087299	ROCCHETTO SELETTORE	SELECTOR SPROCKET	ROCHET SELECTEUR	KLEINRAD GANGWAHL	CORONA SELECTOR	G11	22
800087300	CUSCINETTO	BEARING	ROULEMENT	LAGER	COJINETE	G01	21
						J03	5
800087313	DISTANZIALE	SPACER	ENTRETOISE	ABSTANDHALTER	DISTANCIADOR	G09	19
800087441	SUPPORTO AMMORTIZZATORE	SHOCK ABSORBER SUPPORT	SUPPORT D'AMORTISSEUR	STOSSDÄMPFERBEFESTIGUNG	SOPORTE AMORTIGUADOR	B01	21
800087463	PIASTRINA	PLATE	PLAQUETTE	BLECH	PLACA	B01	13
800087465	PEDANA ANTERIORE SX	LH LOWER FOOTBOARD	CALE-PIED AVANT G.	VORDERE LINKE FUSSRASTE	ESTRIBO APOYAPIE DELANTERO IZQUIERDO	D01	7
800087466	PEDANA ANTERIORE DX	RH FRONT FOOTBOARD	CALE-PIED AVANT D.	VORDERE RECHTE FUSSRASTE	ESTRIBO APOYAPIE DELANTERO DERECHO	D02	7

INDICE CODICI / DENOMINAZIONI

 CODEX / DESIGNATION INDEX • INDEX CODES / DÉNOMINATIONS
 INHALTSVERZEICHNIS CODE • ÍNDICE CÓDIGOS / DENOMINACIONES

Code	Denominazione	Description	Désignation	Bezeichnung	Descripción	Table	N°
800087473	PATTINO SUPERIORE CATENA	CHAIN UPPER PAD	PATIN SUPERIEUR CHAINE	OBERE KETTENFÜHRUNG	PATIN SUPERIOR CADENA	B01	12
800087475	PATTINO INFERIORE CATENA	CHAIN LOWER PAD	PATIN INFERIEUR CHAINE	UNTERE KETTENFÜHRUNG	PATIN INFERIOR CADENA	B01	16
800087476	PATTINO CATENA	CHAIN PAD	PATIN CHAINE	KETTEN-FÜHRUNGSSCHUH	PATIN CADENA	A01	7
800087752	ANELLO DI TENUTA	GROMMET	BAGUE D'ETANCHEITE	DICHTUNGSRING	RETEN	G04	15
800087755	GUARNIZIONE	GASKET	JOINT	DICHTUNG	EMPAQUE	G04	18
800087756	GUARNIZIONE	GASKET	JOINT	DICHTUNG	EMPAQUE	G04	17
800087771	GUARNIZIONE TESTA	HEAD GASKET	JOINT DE CULASSE	ZYLINDERKOPFDICHTUNG	JUNTA CULATA	G03	9
800087779	VITE FISSAGGIO COPERCHIO	COVER CLAMP SCREW	VIS DE FIXATION COUVERCLE	BEFESTIGUNGSSCHRAUBE DECKEL	TORNILLO FIJACION TAPA	G04	19
800087782	ALBERO A CAMME (SCARICO)	CAMSHAFT (EXHAUST)	ARBRE A CAMES (ECH.)	NOCKENWELLE (AUSLASS)	ARBOL DE LEVAS (ESCAPE)	G05	4
800087784	SUPPORTO PATTINO MOBILE	MOVABLE PAD SUPPORT	SUPPORT PATIN MOBILE	HALTERUNG BEWEGLICHE KETTENFÜHRUNG	SOPORTE PATIN MOVIL	G05	14
800087785	PERNO PATTINO MOBILE	PIN FOR MOVABLE PAD	AXE POUR PATIN MOBILE	ZAPFEN FÜR BEWEGLICHE KETTENFÜHRUNG	PERNO PARA PATIN MOVIL	G05	15
800087786	GUARNIZIONE	GASKET	JOINT	DICHTUNG	EMPAQUE	G01	48
800087792	GUARNIZIONE	GASKET	JOINT	DICHTUNG	EMPAQUE	G01	3
800088342	ASTA COMANDO FRIZIONE	CLUTCH CONTROL ROD	TIGE DE DEBRAYAGE	KUPPLUNGSSTANGE	VARILLA ACCIONAMIENTO EMBRAGUE	G09	12
800088343	RUOTA FONICA	PHONIC WHEEL	ROUE PHONIQUE	SENSOR RADDREHUNG	RUEDA FONICA	G10	35
800088344	PROTEZIONE	PROTECTION	PROTECTION	ABDECKUNG	PROTECCION	G11	44
800088346	SENSORE VELOCITÀ	SPEED SENSOR	CAPTEUR DE VITESSE	GESCHWINDIGKEITSSENSOR	SENSOR VELOCIDAD	G11	46
800088347	SPUGNA INSONORIZZANTE	SOUNDPROOFING SPONGE	MOUSSE INSONORISANTE	SCHALLDÄMPFERSCHWAMM	ESPONJA INSONORIZANTE	G11	42
800088418	CUSCINETTO	BEARING	ROULEMENT	LAGER	COJINETE	G09	17
800088526	ROSETTA	WASHER	RONDELLE	UNTERLEGSCHIEBE	ARANDELA	G08	42
800088575	SENSORE TEMPERATURA OLIO/ACQUA	WATER/OIL TEMPERATURE SENSOR	CAPTEUR DE TEMPERATURE D'HUILE/EAU	SENSOR ÖL-WASSER- TEMPERATUR	SENSOR TEMPERATURA ACEITE/AGUA	F04 G15	1 21
800088585	FILTRO BENZINA	FUEL FILTER	FILTRE A ESSENCE	BENZINFILTER	FILTRO GASOLINA	G12	18
800089013	CHIAVE CANDELA	SPARK PLUG WRENCH	CLE A BOUGIE	KERZENSCHLÜSSEL	LLAVE PARA BUJIA	H01	8
800089274	ANELLO RITENUTA	RETAINING RING	JONC DE MAINTIEN	SCHLIESSRING	RETEN	B04 B05	10 10
800089275	DISTANZIALE	SPACER	ENTRETOISE	ABSTANDHALTER	DISTANCIADOR	B04 B05	12 12
800089293	ANTIVIBRANTE	VIBRATION-DAMPER	ANTI-VIBRATIONS	SCHWINGUNGSDÄMPFER	ANTIVIBRANTE	E01 E03 E04 E04 K02	12 15 19 25 7
800089298	GOMMINO	RUBBER COVER	CAOUTCHOUC	GUMMI	GOMA	D01 D02	18 18
800089299	BUSSOLA	BUSH	BAGUE	HÜLSE	CASQUILLO	G16	8
800089300	PIASTRINA	PLATE	PLAQUETTE	BLECH	PLACA	B01	14
800089302	ANTIVIBRANTE	VIBRATION-DAMPER	ANTI-VIBRATIONS	SCHWINGUNGSDÄMPFER	ANTIVIBRANTE	G16	23
800089313	POMPA FRENO POSTERIORE	REAR BRAKE PUMP	MAITRE-CYLINDRE DE FREIN ARRIERE	BREMSPUMPE HINTERRADBREMSE	BOMBA FRENO TRASERO	D02	20
800089335	PROTEZIONE	PROTECTION	PROTECTION	VERKLEIDUNG	PROTECCION	D01	11
800089398	SENSORE PRESSIONE/ TEMPERATURA ARIA	AIR TEMPERATURE/ PRESSURE SENSOR	CAPTEUR PRESS./ TEMPERATURE AIR	SENSOR LUFTDRUCK/ TEMPERATUR	SENSOR PRESION / TEMPERATURA AIRE	F07	6
800089403	MANICOTTO ALIMENTAZIONE	FEED SLEEVE	MANCHON D'ALIMENTATION	MUFFE	MANGUITO ALIMENTACION	G13	19
800089404	FASCETTA A VITE	SCREW CLAMP	COLLIER A VIS	SCHRAUBENSHELLE	ABRAZADERA DE ROSCA	G13	21
800089406	ANELLO TENUTA	GROMMET	BAGUE D'ETANCHEITE	DICHTUNGSRING	RETEN	G11	39
800089410	ANELLO TENUTA	GROMMET	BAGUE D'ETANCHEITE	DICHTUNGSRING	RETEN	G11	7
800089422	PROTEZIONE	PROTECTION	PROTECTION	ABDECKUNG	PROTECCION	G01	49
800089424	ALBERO COMANDO SELETTORE	SELECTOR CONTROL SHAFT	ARBRE DE COMMANDE SELECTEUR	STEUERWELLE GANGWAHL	EJE MANDO SELECTOR	G11	33

INDICE CODICI / DENOMINAZIONI

CODEX / DESIGNATION INDEX • INDEX CODES / DÉNOMINATIONS

INHALTSVERZEICHNIS CODE • ÍNDICE CÓDIGOS / DENOMINACIONES

Code	Denominazione	Description	Désignation	Bezeichnung	Descripción	Table	N°
800089425	TAPPO	PLUG	BOUCHON	VERSCHLUSS	TAPON	G01	18
800089426	ROSETTA	WASHER	RONDELLE	UNTERLEGSCHEIBE	ARANDELA	G01	19
800089440	TUBO LUBRIFICAZIONE	CHANGE GEAR	TUBE GRAISSAGE	SCHMIERLEITUNG	TUBO LUBRICACION		
	CAMBIO	LUBRICATION PIPE	BOITE DE VITESSES	GETRIEBE	CAMBIO	G01	26
800089445	RINVIO COMANDO	TIMING CONTROL RENVOI	COMMANDE DE	VORGELEGE	REENVIO MANDO		
	DISTRIBUZIONE	TRANSMISSION	DISTRIBUTION	VENTILSTEUERUNG	DISTRIBUCION	G05	1
800089484	SPURGO	DRAIN SCREW	VIS DE PURGE	ENTLÜFTUNGSSCHRAUBE	ESPURGO	C01	24
						C02	13
800089491	PARAPOLVERE	DUST COVER	JOINT-POUSSIÈRE	STAUBSCHUTZRING	GUARDAPOLVO	C01	25
						C02	14
800089751	ROSETTA	WASHER	RONDELLE	UNTERLEGSCHEIBE	ARANDELA	A02	9
						B01	39
						E05	29
						E05	30
						E05	31
						G08	79
800089757	DISTANZIALE	SPACER	ENTRETOISE	ABSTANDHALTER	DISTANCIADOR	B02	10
800089759	LEVA COMANDO CAMBIO	GEAR LEVER	LEVIER DE SELECTION	SCHALTPEDALHEBEL	PALANCA ACCIONAMIENTO		
					CAMBIO	D01	16
800089760	ECCENTRICO PER PEDALE	PEDAL ECCENTRIC	EXCENTRIQUE POUR PEDALE	EXZENTER FÜR HEBEL	EXCENTRICO PARA PEDAL	D01	17
						D02	17
800089770	SUPPORTO POMPA	PUMP SUPPORT	SUPPORT DE POMPE	BREMSPUMPENHALTERUNG	SOPORTE BOMBA	D02	30
800089771	SUPPORTO PEDANA	LH FRONT FOOTBOARD	SUPPORT DE CALE-PIED	HALTERUNG VORDERE	SOPORTE ESTRIBO		
	ANTERIORE SX	SUPPORT	AVANT GAUCHE	LINKE FUSSRASTE	APOYAPIE DEL. IZQUIERDO	D01	1
800089772	SUPPORTO PEDANA	RH FRONT FOOTBOARD	SUPPORT DE CALE-PIED	HALTERUNG VORDERE	SOPORTE ESTRIBO		
	ANTERIORE DX	SUPPORT	AVANT DROITE	RECHTE FUSSRASTE	APOYAPIE DEL. DERECHO	D02	1
800089777	PIASTRINA	PLATE	PLAQUETTE	BLECH	PLACA	D01	5
						D02	5
800089778	VITE PER ECCENTRICO	ECCENTRIC SCREW	VIS D'EXCENTRIQUE	SCHRAUBE FÜR EXZENTER	TORNILLO PARA EXCENTRICO	D01	6
						D02	6
800089784	STAFFA DX SERBATOIO	FUEL TANK RH SUPPORT	PATTE D. RESERVOIR	RECHTE TANKBEFESTIGUNG	SOPORTE DER. DEPOSITO	E04	22
800089785	STAFFA SX SERBATOIO	FUEL TANK LH SUPPORT	PATTE G. RESERVOIR	LINKE TANKBEFESTIGUNG	SOPORTE IZQ. DEPOSITO	E04	23
800089786	VITE M6X21	SCREW M6X21	VIS M6X21	SCHRAUBE M6X21	TORNILLO M6X21	A02	10
						B01	15
						E05	3
						E05	8
						E05	11
						G08	38
800089794	TUBO TERMOSTATO/ RADIATORE	THERMOSTAT/RADIATOR PIPE	CANALISATION THERMOSTAT/RADIATEUR	LEITUNG THERMOSTAT/ KÜHLER	TUBO TERMOSTATO/ RADIADOR	G08	64
800089799	CAPPUCCIO SX	LH CAP	CAPUCHON G.	LINKE KAPPE	CAPUCHON IZQUIERDO	G13	4
800089800	CAPPUCCIO DX	RH CAP	CAPUCHON D.	RECHTE KAPPE	CAPUCHON DERECHO	G13	5
800089801	PORTATUBO	PIPE CARRIER	PORTE-CANALISATION	LEITUNGSHALTERUNG	PORTATUBO	G13	1
800089972	INTERRUTTORE MINIMA PRESSIONE OLIO	OIL MIN. PRESSURE SENSOR	MANOCONTACT PRESSION HUILE MIN.	ÖLDRUCKSCHALTER	INTERRUPTOR MINIMA PRESION ACEITE	G15	19
800090184	SENSORE RPM MOTORE	ENGINE RPM SENSOR	CAPTEUR COMPTE-TOURS	SENSOR MOTORDREHZAHL	SENSOR RPM MOTOR	G15	11
800090212	CANDELA CHAMPION G59C	SPARK PLUG CHAMPION G59C	BOUGIE CHAMPION G59C	ZÜNDKERZE CHAMPION G59C	BUJIA CHAMPION G59C	G15	14
800090213	INTERRUTTORE PEDALE STOP	STOP PEDAL SWITCH	CONTACTEUR PEDALE DE STOP	BREMSLICHTSCHALTER BREMSPEDAL	INTERRUPTOR PEDAL STOP	F05	2
800090236	PIASTRA DX TELAIO	CHASSIS RH PLATE	PLAQUE D. CADRE	RECHTE RAHMENPLATTE	PLACA DERECHA BASTIDOR	A01	6
800090239	ANTIVIBRANTE	VIBRATION-DAMPER	ANTI-VIBRATIONS	SCHWINGUNGSDÄMPFER	ANTIVIBRANTE	F01	4
						F06	7
800090244	TUBO CON RIDUZIONE	PIPE WITH ADAPTER	MANCHON DE REDUCTION	LEITUNG MIT REDUZIERSTÜCK	TUBO CON REDUCCION	G08	53
800090245	TUBO DI SPURGO	DRAIN PIPE	TUYAU DE PURGE	ENTLÜFTUNGSLEITUNG	TUBO DE ESPURGO	G08	51
800090249	FORNITURA SERRATURE	LOCKS KIT	FOURNITURE SERRURES	BAUSATZ SCHLÖSSER	SUMINISTRO CERRADURA	D05	1

INDICE CODICI / DENOMINAZIONI

 CODEX / DESIGNATION INDEX • INDEX CODES / DÉNOMINATIONS
 INHALTSVERZEICHNIS CODE • ÍNDICE CÓDIGOS / DENOMINACIONES

Code	Denominazione	Description	Désignation	Bezeichnung	Descripción	Table	N°
800090250	DADO PER SERRATURA	LOCK NUT	ECROU POUR SERRURE	MUTTER FÜR SCHLOSS	TUERCA PARA CERRADURA	E05	28
800090265	SEMIGUSCIO INFERIORE	LOWER HALF BEARING	DEMI-COQUE INFERIEURE	UNTERE SCHALENHÄLFTE	SEMICASCO INFERIOR	D03	3
800090266	PIASTRINA	PLATE	PLAQUETTE	BLECH	PLACA	D03	5
800090275	PEDALE FRENO POSTERIORE	REAR BRAKE PEDAL	PEDALE FREIN ARRIERE	BREMSPEDAL HINTERRADBREMSE	PEDAL FRENO TRASERO	D02	15
800090277	PEDALE CAMBIO	GEAR PEDAL	PEDALE DE SELECTION	SCHALTPEDAL	PEDAL CAMBIO	D01	15
800090307	SUPPORTO FIANCHETTO DX	RH SIDE SUPPORT	SUPPORT DE CACHE D.	HALTERUNG RECHTES SEITENTEIL	SOPORTE LATERAL DERECHO	E04	18
800090312	PROTEZIONE	PROTECTION	PROTECTION	VERKLEIDUNG	PROTECCION	D02	31
800090314	SPINA ELASTICA	SPRING PIN	GOUPILLE FENDUE	SPANNSTIFT	PUA ELASTICA	D01 D02	4 4
800090315	SERBATOIO OLIO FRENO POSTERIORE	REAR BRAKE FLUID SUPPLY TANK	RESERVOIR DE LIQUIDE FREIN ARRIERE	BREMSFLÜSSIGKEITSBEHÄLTER HINTERRADBREMSE	DEPOSITO ACEITE FRENO TRASERO	D02	21
800090316	DECAL	DECAL	ADHESIF	AUFKLEBER	CALCOMANIA	E01 E05	10 2
800090350	GUARNIZIONE	GASKET	JOINT	DICHTUNG	EMPAQUE	G13	13
800090355	CUSCINETTO	BEARING	ROULEMENT	LAGER	COJINETE	C02	2
800090356	DISTANZIALE	SPACER	ENTRETOISE	ABSTANDHALTER	DISTANCIADOR	C02	3
800090372	INDICATORE DI DIREZIONE POSTERIORE DX	RH REAR TURN INDICATOR	FEU CLIGNOTANT ARRIERE D.	HINTERER RECHTER BLINKER	INDICADOR DE DIRECCION TRASERO DERECHO	F06	12
800090373	INDICATORE DI DIREZIONE POST.SX	LH REAR TURN INDICATOR	FEU CLIGNOTANT ARRIERE G.	HINTERER LINKER BLINKER	INDICADOR DE DIRECCION TRASERO IZQUIERDO	F06	18
800090374	CATADIOTTRO	RETROREFLECTOR	REFLECTEUR	KATZENAUGE	CATAFARO	A02	17
800090375	INTERRUTTORE CAVALLETTO LATERALE	SIDE STAND SWITCH	CONTACTEUR BEQUILLE LATERALE	SCHALTER SEITENSTÄNDER	INTERRUPTOR CABALLETE LATERAL	F03	3
800090380	ANTIVIBRANTE	VIBRATION-DAMPER	ANTI-VIBRATIONS	SCHWINGUNGSDÄMPFER	ANTIVIBRANTE	E05	17
800090391	BUSSOLA	BUSH	BAGUE	HÜLSE	CASQUILLO	B01	17
800090392	BUSSOLA	BUSH	BAGUE	HÜLSE	CASQUILLO	A01 E04	8 44
800090399	SUPPORTO PINZA FRENO POSTERIORE	REAR BRAKE CALIPER SUPPORT	SUPPORT ETRIER DE FREIN ARRIERE	HALTERUNG BREMSSEL HINTERRADBREMSE	SOPORTE PINZA FRENO TRASERO	B01	10
800090415	BUSSOLA	BUSH	BAGUE	HÜLSE	CASQUILLO	F06	6
800090416	PERNO PEDANA	FOOTBOARD PIN	AXE CALE-PIED	FUSSRASTENBOLZEN	PERNO ESTRIBO APOYAPIE'	D01 D02	8 8
800090417	FASCETTA IN GOMMA	RUBBER CLAMP	COLLIER EN CAOUTCHOUC	GUMMISCHELLE	CINTA DE GOMA	A01	4
800090418	MOLLA	SPRING	RESSORT	FEDER	MUELLE	D01 D02	10 10
800090419	FLANGIA	FLANGE	FLASQUE	FLANSCH	BRIDA	G16	26
800090429	ANELLO ELASTICO	SNAP RING	CIRCLIP	SPRENGRING	ANILLO DE MUELLE	A02 D01 D02	25 9 9
800090890	DADO ELASTICO	SPRING NUT	ECROU AUTOFREINE	ELASTISCHE MUTTER	TUERCA ELASTICA	D03 D04	12 2
800090894	ROSETTA	WASHER	RONDELLE	UNTERLEGSCHIEBE	ARANDELA	D02 F01	28 35
800090897	ANELLO PARAPOLVERE	DUST COVER RING	JOINT-POUSSIÈRE	STAUBSCHUTZRING	ANILLO GUARDAPOLVO	B03	9
800090910	BUSSOLA	BUSH	BAGUE	HÜLSE	CASQUILLO	F07	7
800090913	ANTIVIBRANTE	VIBRATION-DAMPER	ANTI-VIBRATIONS	SCHWINGUNGSDÄMPFER	ANTIVIBRANTE	E03	17
800090919	GUARNIZIONE	GASKET	JOINT	DICHTUNG	EMPAQUE	G12	8
800090920	POMPA BENZINA	FUEL PUMP	POMPE A ESSENCE	BENZINPUMPE	BOMBA GASOLINA	G12	9
800090921	SUPPORTO ELASTICO	SPRING SUPPORT	SUPPORT SOUPLE	ELASTISCHES LAGERUNGSELEMENT	SOPORTE ELASTICO	G12	12
800090923	GUARNIZIONE	GASKET	JOINT	DICHTUNG	EMPAQUE	E04	15
800090925	TERMINALE DI INNESTO	COUPLER	RACCORD	VERBINDUNGSTEIL	TERMINAL DE ACOPLAMIENTO	G12	5
800090927	TAPPO	PLUG	BOUCHON	VERSCHLUSS	TAPON	G12	2
800090929	REGOLATORE DI PRESSIONE	PRESSURE REGULATOR	REGULATEUR DE PRESSION	DRUCKREGLER	REGULADOR DE PRESION	G12	19

INDICE CODICI / DENOMINAZIONI

 CODEX / DESIGNATION INDEX • INDEX CODES / DÉNOMINATIONS
 INHALTSVERZEICHNIS CODE • ÍNDICE CÓDIGOS / DENOMINACIONES

Code	Denominazione	Description	Désignation	Bezeichnung	Descripción	Table	N°
800090930	ANELLO ELASTICO	SNAP RING	CIRCLIP	SPRENGRING	ANILLO ELASTICO	G12	22
800090939	ANELLO DI TENUTA	GROMMET	BAGUE D'ETANCHEITE	DICHTUNGSRING	RETEN	G12	6
800090940	TUBO IN GOMMA	HOSE	DURIT	GUMMISCHLAUCH	TUBO DE GOMA	E04	8
800090945	ANELLO DI TENUTA	GROMMET	BAGUE D'ETANCHEITE	DICHTUNGSRING	RETEN	G08	47
800090972	TAPPO	PLUG	BOUCHON	VERSCHLUSS	TAPON	G16	4
800090977	PIOLO AGGANCIO FIANCHETTO	SIDE HOOK PIN	PION FIXATION CACHE	HAKEN FÜR SEITENTEIL	ESPIGA ENGANCHE LATERAL	E04	24
800090978	TAMPONE	PAD	TAMPON	PUFFER	TAPON	E04	4
800090979	TAMPONE	PAD	TAMPON	PUFFER	TAPON	B01	25
800090981	SUPPORTO FIANCHETTO SX	LH SIDE SUPPORT	SUPPORT DE CACHE G.	HALTERUNG LINKES SEITENTEIL	SOPORTE LATERAL IZQ.	E04	21
800090998	PIASTRINA	PLATE	PLAQUETTE	BLECH	CHAPA	B01	18
800090999	PIASTRINA	PLATE	PLAQUETTE	BLECH	CHAPA	B01	19
800091005	GRAFFETTA	CLIP	AGRAPHE	KLAMMER	GRAPA	E01	4
800091008	DADO ELASTICO M6	SPRING NUT M6	ECROU AUTOFREINE M6	ELASTISCHE MUTTER M6	TUERCA ELASTICA M6	E03	10
800091011	VALVOLA	VALVE	VALVE	VENTIL	VALVULA	C01	3
						C02	4
800091013	MOZZO ECCENTRICO	ECCENTRIC HUB	MOYEU DECENTRE	EXZENTERNABE	CUBO EXCENTRICO	C01	4
800091022	DADO ELASTICO M4	SPRING NUT M4	ECROU AUTOFREINE M4	ELASTISCHE MUTTER M4	TUERCA ELASTICA M4	B01	29
						E01	15
						E01	20
						E02	16
						E02	20
						F01	6
						G08	13
						G08	16
800091027	PROTEZIONE	PROTECTION	PROTECTION	ABDECKUNG	PROTECCION	B02	8
800091033	DADO M4	NUT M4	ECROU M4	MUTTER M4	TUERCA M4	A02	18
						A02	20
800091064	PRIGIONIERO	STUD BOLT	GOIJON	STIFTSCHRAUBE	ESPARRAGO	G04	4
800091037	TUBO IN GOMMA	HOSE	DURIT	GUMMISCHLAUCH	TUBO DE GOMA	G13	19
800091595	CORNETTO DI ASPIRAZIONE	INTAKE DUCT	CONE D'ADMISSION	ANSAUGSTUTZEN	TUBO DE ASPIRACION	G13	14
800091597	ANELLO DI TENUTA	GROMMET	BAGUE D'ETANCHEITE	DICHTUNGSRING	RETEN	G15	7
800091603	ANELLO ELASTICO	SNAP RING	CIRCLIP	SPRENGRING	ANILLO ELASTICO	G11	8
800091641	TARGHETTA ACQUISIZIONE DATI	DATA PLATE	PLAQUETTE DONNEES	SCHILD FÜR DATEN	ETIQUETA ADQUISICION DATOS	B01	7
800091645	CHIAVE GHIERA CUSCINETTI STERZO	STEERING BEARING RING NUT WRENCH	CLE A GRIFFES ROULEMENTS DIR.	SCHLÜSSEL GEWINDERING LENKLAGER	LLAVE VIROLA COJINETE DIRECCION	J01	2
800091655	PERNO FORCELLONE	FORK PIN	AXE DE BRAS OSCILLANT	SCHWINGENZAPFEN	PERNO HORQUILLA	B01	33
800091682	CATENA	CHAIN	CHAINE	KETTE	CADENA	C01	35
800091683	PIASTRINA	PLATE	PLAQUETTE	BLECH	PLACA	B03	4
800091688	TUBO SCARICO-SFIATO SERBATOIO	EXHAUST PIPE-FUEL TANK BREATHER PIPE	TUYAU VIDANGE-EVENT RESERVOIR	ABLASS- ENTLÜFTUNGS- LEITUNG BENZINTANK	TUBO DESCARGA RESPIRADERO TANQUE	E04	13
800091689	RACCORDO A Y	WYE	RACCORD EN Y	ZWEIWEGEANSCHLUSS	RACOR A Y	E04	12
800091690	TUBO SCARICO SERBATOIO	FUEL TANK DRAIN PIPE	TUYAU DE VIDANGE RESERVOIR	TANK-ABLASSLEITUNG	TUBO DESCARGA TANQUE	E04	11
800091691	VITE PER RACCORDI IDRAULICI	HYDRAULIC UNION SCREW	VIS POUR RACCORDS HYDRAULIQUE	SCHRAUBE FÜR ANSCHLÜSSE HYDRAULIKLEITUNGEN	TORNILLO PARA CONEXION HIDRAULICA	D04	9
800091692	VITE PER RACCORDI IDRAULICI	HYDRAULIC UNION SCREW	VIS POUR RACCORDS HYDRAULIQUE	SCHRAUBE FÜR ANSCHLÜSSE HYDRAULIKLEITUNGEN	TORNILLO PARA CONEXION HIDRAULICA	D02	35
						D03	18
						D04	8
800091695	TUBO SFIATO SERBATOIO	FUEL TANK BREATHER PIPE	TUYAU D'EVENT RESERVOIR	TANK-ENTLÜFTUNGSLEITUNG	TUBO RESPIRADERO TENQUE	E04	10
800091697	VITE M8X30	SCREW M8X30	VIS M8X30	SCHRAUBE M8X30	TORNILLO M8X30	G11	48
800091707	TAPPO	PLUG	BOUCHON	VERSCHLUSS	TAPON	G08	49
800091886	INGRANAGGIO INTERMEDIO	IDLER GEAR	PIGNON INTERMEDIAIRE	ZWISCHEN-ZAHNRAD	ENGRANAJE INTERMEDIO	G14	14
800091895	TENDICATENA	CHAIN TIGHTENER	TENDEUR DE CHAINE	KETTENSANNER	TENSIONADOR DE CADENA	G05	17
800091897	ALBERO MOTORE COMPLETO	DRIVING SHAFT ASSEMBLY	VILEBREQUIN COMPLET	KURBELWELLE KOMPLETT	CIGÜEÑAL COMPLETO	G02	1

INDICE CODICI / DENOMINAZIONI

 CODEX / DESIGNATION INDEX • INDEX CODES / DÉNOMINATIONS
 INHALTSVERZEICHNIS CODE • ÍNDICE CÓDIGOS / DENOMINACIONES

Code	Denominazione	Description	Désignation	Bezeichnung	Descripción	Table	N°
800091898	ALBERO MOTORE	DRIVING SHAFT	VILEBREQUIN	KURBELWELLE	CIGÜEÑAL	G02	2
800091905	MOTORE COMPLETO	ENGINE ASSEMBLY	MOTEUR COMPLET	MOTOR KOMPLETT	MOTOR COMPLETO	G01	59
800091914	UGELLO OLIO PISTONE	PISTON OIL NOZZLE	TUYERE D'HUILE DE PISTON	ÖLDÜSE FÜR KOLBEN	TUBO DEL ACEITE PARA PISTON	G06	34
800091915	ASSIEME UGELLI OLIO PISTONI	PISTON OIL NOZZLES ASSEMBLY	ENSEMBLE TUYERES D'HUILE DE PISTONS	BAUGRUPPE ÖLDÜSEN FÜR KOLBEN	CONJUNTOTUBOS DEL ACEITE PARA PISTONES	G06	33
800091924	DADO M22	NUT M22	ECROU M22	MUTTER M22	TUERCA M22	G09 G10	3 34
800091926	MOZZO PORTADISCHI	DISK HUB	NOIX D'EMBRAYAGE	KUPPLUNGSSCHEIBENNABE	CUBO PORTADISCOS	G09	1
800092185	FANALE TARGA	NUMBER PLATE LIGHT	ECLAIREUR	NUMMERNSCHILDBELEUCHTUNG	LUZ PLACA	F06	23
800092247	FASCETTA IN GOMMA	RUBBER CLAMP	COLLIER EN CAOUTCHOUC	GUMMISCHELLE	CINTA DE GOMA	E05 F03 F04 F05 F06	13 8 4 11 28
800092248	FASCETTA IN GOMMA	RUBBER CLAMP	COLLIER EN CAOUTCHOUC	GUMMISCHELLE	CINTA DE GOMA	D03 D04 D04 F03 F03 F04 G08	36 12 30 9 10 3 63
800092256	FASCETTA CLIC R	CLIC R CLAMP	COLLIER CLIC R	SHELLE CLIC R	ABRAZADERA	G08	52
800092257	TARGHETTA BATTERIA	BATTERY DATA PLATE	PLAQUETTE BATTERIE	BATTERIE-TYPENSCHILD	ETIQUETA BATERIA	A02	2
800092433	SEMICONO PER VALVOLA	COTTERS	DEMI-CLAVETTE DE SOUPAPE	HALBKEGEL FÜR VENTIL	SEMICONO PARA VALVULA	G04	14
800092473	TAPPO	PLUG	BOUCHON	VERSCHLUSS	TAPON	G01	43
800092490	MOLLA	SPRING	RESSORT	FEDER	MUELLE	G11	30
800092630	FERMAGLIO PER CAVI	CABLES CLIP	FIXATION POUR CABLES	KLEMMRING FÜR GASZÜGE	CLIP PARA CABLES	D03	10
800092631	ANTIVIBRANTE	VIBRATION-DAMPER	ANTI-VIBRATIONS	SCHWINGUNGSDÄMPFER	ANTIVIBRANTE	B01	23
800092642	CAVALLETTO POSTERIORE	REAR STAND	BEQUILLE ARRIERE	HINTERER STÄNDER	CABALLETE TRASERO	H01	4
800092652	PATTINO SUPERIORE CATENA	CHAIN UPPER PAD	PATIN SUPERIEUR CHAINE	OBERE KETTENFÜHRUNG	PATIN SUPERIOR CADENA	B01	12
800092658	BUSSOLA	BUSH	BAGUE	HÜLSE	CASQUILLO	A01	33
800092659	VITE M5X8	SCREW M5X8	VIS M5X8	SCHRAUBE M5X8	TORNILLO M5X8	F01	7
800092661	FASCETTA IN NYLON	NYLON CLAMP	COLLIER EN NYLON	NYLONSHELLE	CINTA DE NYLON	F01	33
800092664	DECAL	DECAL	ADHESIF	AUFKLEBER	CALCOMANIA	E04	1
800092667	TARGHETTA REGOLAZIONE CATENA	CHAIN ADJUSTMENT PLATE	PLAQUETTE REGLAGE CHAINE	SCHILD KETTENEINSTELLUNG	ETIQUETA REGULACION CADENA	B01	28
800092668	FASCETTA IN GOMMA	RUBBER CLAMP	COLLIER EN CAOUTCHOUC	GUMMISCHELLE	CINTA DE GOMA	F03 F06 F07	11 25 18
800092670	BUSSOLA	BUSH	BAGUE	HÜLSE	CASQUILLO	B01 E01 E01	37 6 8
800092849	COPRICATENA SUPERIORE	UPPER CHAIN COVER	CARTER DE CHAINE SUPERIEUR	OBERER KETTENSCHUTZ	CUBRECADENA SUPERIOR	B01	24
800092857	CHIAVE GHIERA ECCENTRICO STERZO	STEERING ECCENTRIC RING NUT WRENCH	CLE POUR ECROU DECENTRE DIR.	SCHLÜSSEL GEWINDERING LENKEXZENTER	LLAVE VIROLA EXCENTRICO DIRECCION	J01	3
800092860	ESTRATTORE CUSCINETTI FORCELLONE	FORK BEARING EXTRACTOR	EXTRACTEUR ROULEMENTS BRAS OSC.	AUSZIEHER SCHWINGENLAGER	EXTRACTOR COJINETE HORQUILLA	J01	4
800092861	BOCCOLA ESTRATTORE CUSCINETTI	BEARING EXTRACTOR BUSH	DOUILLE EXTRACTEUR ROULEMENTS	BUCHE LAGERAUSZIEHER	BUJE EXTRACTOR COJINETES	J01	5
800092862	ESTRATTORE CUSCINETTI RUOTA ANTERIORE	FRONT WHEEL BEARING EXTRACTOR	EXTRACTEUR ROULEMENTS ROUE AVANT	AUSZIEHER VORDERRADLAGER	EXTRACTOR COJINETES RUEDA DELANTERA	J01	6
800092863	CHIAVE CPC	CPC WRENCH	CLE CPC	SCHLÜSSEL CPC	LLAVE CPC	J01	7
800092865	ATTREZZO BILANCIAMENTO RUOTA POSTERIORE	REAR WHEEL BALANCING TOOL	OUTIL EQUILIBRAGE ROUE ARRIERE	WERKZEUG AUSWUCHTEN HINTERRAD	UTIL BALANCEAMIENTO RUEDA TRASERA	J01	9
800092866	ATTREZZO PACCO FORCELLONE	FORK PACK TOOL	OUTIL PAQUET BRAS OSCILLANT	WERKZEUG SCHWINGENPAKET	UTIL PAQUETE HORQUILLA	J01	12

**INDICE CODICI / DENOMINAZIONI**

CODEX / DESIGNATION INDEX • INDEX CODES / DÉNOMINATIONS

INHALTSVERZEICHNIS CODE • ÍNDICE CÓDIGOS / DENOMINACIONES

Code	Denominazione	Description	Désignation	Bezeichnung	Descripción	Table	N°
800092867	ATTREZZO PACCO BILANCIERE	EQUALIZER PACK TOOL	OUTIL PAQUET BALANCIER	WERKZEUG SCHWINGHEBELPAKET	UTIL PAQUETE BALANCIN	J02	1
800092868	ATTREZZO CUSCINETTI RUOTA ANTERIORE	FRONT WHEEL BEARINGS TOOL	OUTIL ROULEMENTS ROUE AVANT	WERKZEUG VORDERRADLAGER	UTIL COJINETE RUEDA DELANTERA	J02	2
800092872	CHIAVE PERNO RUOTA ANTERIORE	FRONT WHEEL PIN WRENCH	CLE AXE ROUE AVANT	SCHLÜSSEL LLAVE VORDERRADACHSE	PERNO RUEDA DELANTERA	J01	1
800092882	ROSETTA	WASHER	RONDELLE	UNTERLEGSCHNEIBE	ARANDELA	B01 E01 E01 E01 E02 E02 E04	40 21 22 24 21 22 43
800092886	MOLLA RITEGNO PASTIGLIE	PADS CHECK SPRING	PLAQUETTE D'APPUI	RÜCKHALTEFEDER BREMSBELÄGE	MUELLE RETENCION PASTILLAS	C02	11
800092888	PERNO RUOTA POSTERIORE	REAR WHEEL PIN	AXE ROUE ARRIERE	HINTERRADACHSE	PERNO RUEDA TRASERA	C01	7
800092890	ECCENTRICO REGOLAZ. PEDANA DX	RH FOOTBOARD ADJUSTMENT ECCENTRIC	EXCENTRIQUE DE REGLAGE CALE-PIED D.	EINSTELLUNGSEXZENTER RECHTE FUSSRASTE	EXCENTRICO REGULACION ESTRIBO DERECHO	D02	3
800092891	ECCENTRICO REGOLAZ. PEDANA SX	LH FOOTBOARD ADJUSTMENT ECCENTRIC	EXCENTRIQUE DE REGLAGE CALE-PIED G.	EINSTELLUNGSEXZENTER LINKE FUSSRASTE	EXCENTRICO REGULACION ESTRIBO IZQUIERDO	D01	3
800092894	SEMIGUSCIO SUPERIORE	UPPER HALF BEARING	DEMI-COQUE SUPERIEURE	OBERE SCHALENHÄLFTE	SEMICASCO SUPERIOR	D03	2
800093018	FUSIBILE 40A	FUSE 40A	FUSIBLE 40A	SICHERUNG 40A	FUSIBLE 40A	F05	4
800093297	VITE M5X8	SCREW M5X8	VIS M5X8	SCHRAUBE M5X8	TORNILLO M5X8	D03	6
800093298	LEVA FRIZIONE	CLUTCH LEVER	LEVIER D'EMBRAYAGE	KUPPLUNGSHABEL	PALANCA EMBRAGUE	D04	13
800093299	PERNO PER LEVA	LEVER PIN	AXE DE LEVIER	HEBELBOLZEN	PERNO PARA PALANCA	D03 D04	20 14
800093300	DADO PER LEVA	LEVER NUT	ECROU DE LEVIER	MUTTER FÜR HEBEL	TUERCA PARA PALANCA	D03 D04	21 15
800093302	DIAFRAMMA	DIAPHRAGM	DIAPHRAGME	MEMBRAN	DIAFRAGMA	D03	28
800093303	GUARNIZIONE	GASKET	JOINT	DICHTUNG	EMPAQUE	D03	29
800093306	ANELLO DI TENUTA	GROMMET	BAGUE D'ETANCHEITE	DICHTUNGSRING	RETEN	D03 D04	32 26
800093307	INTERRUTTORE FRIZIONE	CLUTCH SWITCH	CONTACTEUR EMBRAYAGE	KUPPLUNGSSCHALTER	INTERRUPTOR EMBRAGUE	D04	16
800093310	TAPPO	PLUG	BOUCHON	VERSCHLUSS	TAPON	D04	20
800093311	DIAFRAMMA	DIAPHRAGM	DIAPHRAGME	MEMBRAN	DIAFRAGMA	D04	22
800093312	GUARNIZIONE	GASKET	JOINT	DICHTUNG	EMPAQUE	D04	23
800093313	VITE M4X16	SCREW M4X16	VIS M4X16	SCHRAUBE M4X16	TORNILLO M4X16	D03 D04 D04	27 17 21
800093314	LEVA COMANDO FRENO POSTERIORE	REAR BRAKE LEVER	LEVIER DE COMMANDE FREIN ARRIERE	BREMSPEDALHEBEL HINTERRADBREMSE	PALANCA ACCIONAMIENTO FRENO TRASERO	D02	16
800093315	BASE DI STERZO CON PERNO	STEERING BASE WITH PIN	TETE INFERIEUR AVEC AXE	LENKAUFLAGE MIT ZAPPEN	BASE DE LA DIRECCION CON PERNO	B03	3
800093316	FORCELLONE POSTERIORE	REAR FORK	BRAS OSCILLANT	HINTERE SCHWINGE	HORQUILLA TRASERA	B01	1
800093318	SEMIBIELLA SUPERIORE	UPPER HALF SUPPORT	DEMI-BIELLE SUPERIEURE	OBERE SCHUBSTANGENHÄLFTE	SEMIBIELLA SUPERIOR	B02	1
800093319	SEMIBIELLA INFERIORE	LOWER HALF SUPPORT	DEMI-BIELLE INFERIEURE	UNTERE SCHUBSTANGENHÄLFTE	SEMIBIELLA INFERIOR	B02	2
800093320	BILANCIERE COMPLETO	EQUALIZER ASSEMBLY	BALANCIER COMPLET	KIPPHEBEL KOMPLETT	BALANCIN COMPLETO	B02	9
800093323	ANELLO DI TENUTA	GROMMET	BAGUE D'ETANCHEITE	DICHTUNGSRING	RETEN	G12	20
800093324	ANELLO DI TENUTA	GROMMET	BAGUE D'ETANCHEITE	DICHTUNGSRING	RETEN	G12	21
800093335	FANALE POSTERIORE	TAIL LAMP	FEU ARRIERE	RÜCKLICHT	PILOTO TRASERO	F06	2
800093336	TRASPARENTE	GLASS	CABOCHON	BLINKERGLAS	TRASPARENTE	F01 F06	17 13
800093337	TRASPARENTE	GLASS	CABOCHON	BLINKERGLAS	TRASPARENTE	F01 F06	24 19
800093338	CHIAVE GREZZA	VIRGIN IGNITION LOCK KEY	CLE BRUTE	SCHLÜSSELROHLING	LLAVE NO ACABADA	D05	5

INDICE CODICI / DENOMINAZIONI

 CODEX / DESIGNATION INDEX • INDEX CODES / DÉNOMINATIONS
 INHALTSVERZEICHNIS CODE • ÍNDICE CÓDIGOS / DENOMINACIONES

Code	Denominazione	Description	Désignation	Bezeichnung	Descripción	Table	N°
800093339	INTERRUTTORE ACCENSIONE CON CHIAVI	IGNITION LOCK SWITCH WITH KEYS	CONTACTEUR D'ALLUMAGE AVEC CLES	ZÜNDSCHLOSS MIT SCHLÜSSELN	INTERRUPTOR DE ENCENDIDO CON LLAVE	D05	2
800093340	TAPPO SERB. CARBURANTE CON CHIAVI	FILLERCAP WITH KEYS	BOUCHON RES. CARBURANT AVEC CLES	TANKSCHLOSS MIT SCHLÜSSELN	TAPA DEL TANQUE DEL COMBUSTIBLE CON LLAVE	D05	3
800093341	SERRATURA SELLA CON CHIAVI	SADDLE LOCK WITH KEYS	SERRURE DE SELLE AVEC CLES	SITZBANKSCHLOSS MIT SCHLÜSSELN	CERRADURA SILLIN CON LLAVE	D05	4
800093347	ASTA SETTAGGIO SOSPENSIONE POST.	REAR SUSPENSION ADJUSTING ROD	TIGE DE REGLAGE SUSPENSION AR.	EINSTELLSTANGE HINTERRADFEDERUNG	VARILLA AJUSTE SUSPENSION TRASERA	J02	5
800093410	CONVOGLIATORE POMPA BENZINA	FUEL PUMP CONVEYOR	CONVOYEUR POMPE A ESSENCE	ZULEITUNG BENZINPUMPE	TRANSPORTADOR BOMBA GASOLINA	G12	10
800093411	ANELLO DI SICUREZZA	SAFETY RING	JONC	SICHERUNGSRING	ANILLO DE SEGURIDAD	G12	11
800093414	PORTADOCUMENTI	DOCUMENT HOLDER	POCHETTE POUR PAPIERS	DOKUMENTENMAPPE	PORTADOCUMENTOS	H01	7
800093416	VITE AUTOFILETTANTE 2,9X16	TAPPING SCREW 2,9X16	VIS TARAUD 2,9X16	BLECHSCHRAUBE 2,9X16	TORNILLO AUTOENROSCANTE 2,9X16	F01 F01 F06 F06	16 23 15 21
800093852	BASE DI STERZO CON PERNO	STEERING BASE WITH PIN	TETE INFERIEUR AVEC AXE	LENKAUFLAGE MIT ZAPFEN	BASE DE LA DIRECCION CON PERNO	B03	3
800093854	FORCELLONE POSTERIORE	REAR FORK	BRAS OSCILLANT	HINTERE SCHWINGE	HORQUILLA TRASERA	B01	1
800093855	COPRICATENA INFERIORE	LOWER CHAIN COVER	CARTER DE CHAINE INFERIEUR	UNTERER KETTENSCHUTZ	CUBRECADENA INFERIOR	B01	27
800093864	MAGLIA GIUNZIONE CATENA	CHAIN LINK	MAILLON DE JONCTION CHAINE	KETTENSCHLOSS	ESLABON UNION CADENA	C01	2
800094019	TARGHETTA "RETROVISORE"	"REARVIEW" MIRROR DATA PLATE	PLAQUETTE "RETROVISEUR"	SCHILD "RÜCKSPIEGEL"	ETIQUETA "RETROVISORES"	K01	4
800094022	PINZA FRENO ANTERIORE DX	RH FRONT BRAKE CALIPER	ETRIER DE FREIN AVANT D.	VORDERER RECHTER BREMSSATTEL	PINZA FRENO DELANTERA DERECHA	C02	15
800094023	PINZA FRENO ANTERIORE SX	LH FRONT BRAKE CALIPER	ETRIER DE FREIN AVANT G.	VORDERER LINKER BREMSSATTEL	PINZA FRENO DELANTERA IZQUIERDA	C02	9
800094024	COPIA PASTIGLIE FRENO ANTERIORE	FRONT BRAKE PADS	PAIRE DE PLAQUETTES FREIN AVANT	BREMSBELAGPAAR VORDERRADBREMSE	PAR DE PASTILLAS FRENO DELANTERO	C02	10
800094025	POMPA FRENO ANTERIORE	FRONT BRAKE PUMP	MAITRE-CYLINDRE FREIN AVANT	BREMSPUMPE VORDERRADBREMSE	BOMBA FRENO DELANTERO	D03	18
800094030	PROTEZIONE FERMAGLIO	CLIP PROTECTION	PROTECTION	KLEMMRINGSICHERUNG	PROTECCION CLIP	C01	36
800094170	MOLLA	SPRING	RESSORT	FEDER	MUELLE	A02	27
800094171	BUSSOLA ROTAZIONE PEDANA POSTERIORE	REAR FOOTBOARD SWING BUSH	BAGUE ROTATION CALE-PIED ARRIERE	DREHBUCHSE HINTERE FUSSRASTE	CASQUILLO ROTACION ESTRIBO TRASERO	A02	23
800094279	RIVETTO	RIVET	RIVET	NIETE	REMACHE	A02	33
800094318	COPRIMANOPOLA	KNOB COVER	GAINÉ POUR POIGNEES	HANDGRIFFSCHUTZ	CUBRE PUÑO	H01	3
800094505	RITEGNO PER BATTERIA	BATTERY HOLDER	CALE POUR BATTERIE	BEFESTIGUNG FÜR BATTERIE	SUJETADOR PARA BATERIA	E05	18
800094506	FLANGIA PORTATARGA/ CATADIOTTRO	NUMBER PLATE HOLDER/ RETROREFLECTOR	FLASQUE SUPPORT DE PLAQUE/FLANGE REFLECTEUR	BEFESTIGUNGSFLANSCH NUMMERN SCHILDBEFESTI- GUNG/KATZENAUGE	BRIDA PORTAPLACA/ CATAFARROS	A02	14
800094529	TUBO COMANDO GAS CON MANOPOLE	THROTTLE CONTROL PIPE WITH KNOBS	TUBE COMMANDE GAZ AVEC POIGNEES	ROHR GASGRIFF MIT HANDGRIFF	TUBO MANDO GAS CON PUÑO	D03	7
800094626	ANELLO DI TENUTA	GROMMET	BAGUE D'ETANCHEITE	DICHTUNGSRING	RETEN	G01	46
800094628	CERCHIO RUOTA ANTERIORE	FRONT RIM	JANTE ROUE AVANT	VORDERRADFELGE	LLANTA RUEDA DELANTERA	C02	1
800094640	COMANDO GAS COMPLETO	THROTTLE CONTROL ASSEMBLY	COMMANDE GAZ COMPLETE	GASGRIFF KOMPLETT	MANDO GAS COMPLETO	D03	1
800094643	ANELLO ELASTICO	SNAP RING	CIRCLIP	SPRENGRING	ANILLO ELASTICO	D03 D04	34 28
800094792	ATTREZZO MONTAGGIO CAMBIO	CHANGE GEAR ASSEMBLY TOOL	OUTIL MONTAGE BOITE DE VITESSES	WERKZEUG GETRIEBEMONTAGE	UTIL MONTAJE CAMBIO	J03	1
800094794	ATTREZZO SUPPORTO PARASTRAPPI	SPRING DRIVE SUPPORT TOOL	OUTIL SUPPORT FLECTEUR	WERKZEUG HALTERUNG REISSCHUTZ FLEXIBLE	UTIL SOPORTE ACOPLAMIENTO	J03	10
800094795	ATTREZZO RINVIO ALBERO ALTERNATORE	ALTERNATOR SHAFT TRANSMISSION TOOL	OUTIL RENVOI ARBRE ALTERNATEUR	WERKZEUG VORGELEGE LICHTMASCHINENWELLE	UTIL REENVIO EJE ALTERNADOR	J03	9

INDICE CODICI / DENOMINAZIONI

CODEX / DESIGNATION INDEX • INDEX CODES / DÉNOMINATIONS

INHALTSVERZEICHNIS CODE • ÍNDICE CÓDIGOS / DENOMINACIONES

Code	Denominazione	Description	Désignation	Bezeichnung	Descripción	Table	N°
800094796	ATTREZZO MONTA/SMONTA VALVOLE	VALVES ASSEMBLY/ DISASSEMBLY TOOL	OUTIL LEVE-SOUPAPE	WERKZEUG ZUM EIN-/ AUSBAU VENTILE	UTIL MONTAJE DESMONTAJE VALVULA	J03	14
800094797	LASTRA SAGOMATA COPRI TESTA	HEAD COVER SHAPED PLATE	PLAQUE COUVRE-CULASSE	ABDECKSCHABLONE L ZYLINDERKOPF	AMINA PERFILADA CUBRE CULATA	J03	8
800094798	ATTREZZO GOMMINI VALVOLA	VALVE RUBBER RINGS TOOL	OUTIL CAOUTCHOUC SOUPAPE	WERKZEUG VENTILGUMMI	UTIL CAUCHOS VALVULA	J03	11
800094860	LAMPADA	BULB	AMPOULE	LAMPE	LAMPARA	F01	3
800094861	LAMPADA	BULB	AMPOULE	LAMPE	LAMPARA	F01	2
800094890	CAPPUCCIO POLO POSITIVO BATTERIA	BATTERY POSITIVE POLE CAP	CAPUCHON POLE POSITIF BATTERIE	KAPPE PLUSPOL BATTERIE	CAPUCHON POLO POSITIVO BATERIA	F05	8
800094895	TAPPO	PLUG	BOUCHON	VERSCHLUSS	TAPON	B01	36
800094896	CAPPUCCIO	CAP	CAPUCHON	KAPPE	CAPUCHON	G01	37
800095179	ATTREZZO SMONTAGGIO SEMICONI	HALF-CONES DISASSEMBLING TOOL	OUTIL POUR LE DÉMONTAGE DES MOITIÉ-CÔNES	WERKZEUG FÜR DAS HÄLFTE-KEGELAUSEINANDERBAUEN	UTIL PARA EL DESMONTAJE DE LOS MITAD-CONOS	J04	9
800095180	ATTREZZO MONTAGGIO SEMICONI	HALF-CONES ASSEMBLING TOOL	OUTIL POUR LE MONTAGE DES MOITIÉ-CÔNES	WERKZEUG FÜR DAS HÄLFTE-KEGELZUSAMMENBAUEN	UTIL PARA EL MONTAJE DE LOS MITAD-CONOS	J04	10
800095318	TAMPONE PER SEDE VALVOLA SCARICO	PAD FOR EXHAUST VALVE SEAT	TAMPON POUR LE SIÈGE DE SOUPAPE D'ÉCHAPPEMENT	AUFLAGE FÜR AUSLASSVENTILSITZ	COJÍN PARA EL ASIENTO DE LA VÁLVULA DE ESCAPE	J04	11
800095319	TAMPONE PER SEDE VALVOLA ASPIRAZIONE	PAD FOR INTAKE VALVE SEAT	TAMPON POUR LE SIÈGE DE SOUPAPE D'ADMISSION	AUFLAGE FÜR EINLASSVENTILSITZ	COJÍN PARA EL ASIENTO DE LA VÁLVULA DE ADMISION	J04	12
800095366	TARGHETTA BENZINA	FUEL DATA PLATE	PLAQUETTE ESSENCE	SCHILD BENZIN	ETIQUETA GASOLINA	K01	3
800095389	ATTREZZO CATENA	CHAIN TOOL OUTIL	CHAINE	WERKZEUG KETTE	UTIL CADENA	J02	3
800095390	PERNO TAGLIO E RIBADITURA	RIVETING AND CUTTING PIN	AXE COUPE ET RIVETAGE	SCHNITT- UND NIETZAPFEN	PERNO CORTE Y REMACHADO	J02	4
800095396	VERNICE ORO MAGNESIO	GOLD MAGNESIUM PAINT	PEINTURE OR MAGNESIUM	LACK MAGNESIUMGOLD	PINTURA ORO MAGNESIO	J02	13
800095429	TAMPONE CONTROLLO	CONTROL PAD	TAMPON CONTROLE	KONTROLLPUFFER	TAPON CONTROL	J03	16
800095484	CATADIOTTRO	RETROREFLECTOR	REFLECTEUR	KATZENAUGE	CATAFARO	K01	1
800095485	CATADIOTTRO	RETROREFLECTOR	REFLECTEUR	KATZENAUGE	CATA FARO	K01	2
800095486	CATADIOTTRO	RETROREFLECTOR	REFLECTEUR	KATZENAUGE	CATAFARO	K01	8
800095487	CATADIOTTRO	RETROREFLECTOR	REFLECTEUR	KATZENAUGE	CATAFARO	K01	9
800095500	ANTIVIBRANTE	VIBRATION-DAMPER	ANTI-VIBRATIONS	SCHWINGUNGSDÄMPFER	ANTIVIBRANTE	F06	5
800095505	ROSETTA	WASHER	RONDELLE	UNTERLEGSCHIEBE	ARANDELA	G06	18
800095581	PUNZONE MONTAGGIO TENUTE VALVOLA	VALVE SEAL ASSEMBLY TOOL	POUSSOIR MONTAGE JOINTS SOUPAPES	SCHLAGDORN VENTILDICHTUNGEN	MONTAGE PUNZON MONTAJE ESTANQUEIDAD VALVULA	J03	17
800095807	CAVALLETTO ANTERIORE	FRONT STAND	BEQUILLE AVANT	VORDERER STÄNDER	CABALLETE DELANTERO	J02	6
800095808	PERNO CAVALLETTO ANTERIORE	FRONT STAND PIN	AXE BEQUILLE AVANT	VORDERER STÄNDERBOLZEN	PERNO CABALLETE DELANTERO	J02	7
800095828	ANTIVIBRANTE	VIBRATION-DAMPER	ANTI-VIBRATIONS	SCHWINGUNGSDÄMPFER	ANTIVIBRANTE	A02 A02 E01 E02	12 31 17 18
800095842	TARGHETTA MARCE	GEARS DATA PLATE	PLAQUETTE VITESSES	SCHILD GÄNGE	ETIQUETA MARCHAS	K01	5
800095845	SILENZIATORI DI SCARICO	SILENCERS	SILENCIEUX D'ÉCHAPPEMENT	SCHALLDÄMPFER	SILENCIADOR DE ESCAPE	G16	15
800095847	SEMIGUSCIO INFERIORE	LOWER HALF BEARING	DEMI-COQUE INFERIEURE	UNTERE SCHALENHÄLFTE	SEMICASCO INFERIOR	D03	3
800095848	COMANDO GAS COMPLETO	THROTTLE CONTROL ASSEMBLY	COMMANDE GAZ COMPLETE	GASGRIFF KOMPLETT	MANDO GAS COMPLETO	D03	1
800095850	PINZA MONTA/SMONTA FASCETTE CLIC	CLIC CLAMPS ASSEMBLY/ DISASSEMBLY PLIERS	PINCE POUR COLLIERS CLIC	ZANGE EIN-/ AUSBAU SCHELLEN CLIC	PINZA MONTAJE/ DESMONTAJE ABRAZADERAS	J01	10
800095906	CANDELA NGK CR9EB	SPARK PLUG NGK CR9EB	BOUGIE NGK CR9EB	ZÜNDKERZE NGK CR9EB	BUJIA NGK CR9EB	G15	14
800096426	INGRANAGGIO PRIMARIA - ALTERNATORE	MAIN GEAR - ALTERNATOR GEAR	PIGNON PRIMAIRE - ALTERNATEUR	ZAHNRAD ANTRIEBSWELLE - LICHTMASCHINE	ENGRANAJE PRIMARIO - ALTERNADOR	G09	16
800096458	FASCETTA CLIC	CLIC CLAMP	COLLIER CLIC	SHELLE CLIC	ABRAZADERA CLIC	G13 K02 K02	22 15 21
800096565	ROSETTA	WASHER	RONDELLE	UNTERLEGSCHIEBE	ARANDELA	G10	38
800096598	CATENA DISTRIBUZIONE APERTA	OPEN TIMING CHAIN	CHAINE DISTRIBUTION OUVERTE	VENTILSTEUERKETTE OFFEN	CADENA DISTRIBUCION ABIERTA	G05	6
800096747	TAPPO	PLUG	BOUCHON	VERSCHLUSS	TAPON	G01	52

INDICE CODICI / DENOMINAZIONI

 CODEX / DESIGNATION INDEX • INDEX CODES / DÉNOMINATIONS
 INHALTSVERZEICHNIS CODE • ÍNDICE CÓDIGOS / DENOMINACIONES

Code	Denominazione	Description	Désignation	Bezeichnung	Descripción	Table	N°
800097084	CANISTER	CARBON CANISTER	CANISTER	CARBONKANISTER	CANISTER	K02	1
800097088	RACCORDO A 5 VIE	5-WAY FITTING	RACCORD A 5 DIRECTIONS	5-WEISE ANSCHLUSS	RACOR A 5 VIAS	K02	17
800097090	TUBO IN GOMMA	HOSE	DURIT	GUMMISCHLAUCH	TUBO DE GOMA	K02	19
800097101	CRUSCOTTO COMPLETO	DASHBOARD ASSEMBLY	COMBINE DE BORD COMPLET	ARMATURENBRETT KOMPLETT	TABLERO COMPLETO	F01	1
800097112	ANTIVIBRANTE	VIBRATION-DAMPER	ANTI-VIBRATIONS	SCHWINGUNGSDÄMPFER	ANTIVIBRANTE	E02	18
800097113	VITE FISSAGGIO PROIETTORE	HEADLIGHT CLAMP SCREW	VIS DE FIXATION PROJECTEUR	SCHWEINWERFER BEFESTIGUNGSSCHRAUBE	TORNILLO FIJACION PROYECTOR	F02	9
800097121	SERBATOIO OLIO FRENO ANTERIORE	FRONT BRAKE FLUID SUPPLY TANK	RESERVOIR DE LIQUIDE FREIN AVANT	BREMFLÜSSIGKEITSBEHÄLTER VORDERRADBREMSE	DEPOSITO ACEITE FRENO DELANTERO	D03	25
800097122	SERBATOIO OLIO POMPA FRIZIONE	CLUTCH PUMP OIL TANK	RESERV. FLUIDE MAITRE- CYLINDRE EMBRAYAGE	KUPPLUNGSFÜSSIGKEITS- BEHÄLTER	DEPOSITO ACEITE BOMBA EMBRAGUE	D04	19
800097124	PROIETTORE ANTERIORE	HEADLIGHT	PROJECTEUR AVANT	SCHWEINWERFER	PROYECTOR DELANTERO	F02	1
800097126	ASSIEME REGOLAZIONE	ADJUSTMENT ASSEMBLY	GROUPE DE REGLAGE	EINSTELLUNG EINHEIT	GRUPO DE REGULACION	F02	3
800097250	TESTA CILINDRI COMPLETA	CYLINDER HEAD ASSEMBLY	CULASSE COMPLETE	ZYLINDERKOPF KOMPLETT	CULATA COMPLETA	G04	1
800097278	STAFFA ALTERNATORE	ALTERNATOR CLAMP	BRIDE ALTERNATEUR	BEFESTIGUNG LICHTMASCHINE	BRIDA ALTERNADOR	G15	5
800097867	SUPPORTO MOTORE	ENGINE MOUNTING	SUPPORT MOTEUR	MOTORHALTER	SOPORTE MOTOR	J03	19
800097880	SILENZIATORE INFERIORE	LOWER SILENCER	SILENCIEUX INFERIEUR	UNTERER SCHALLDÄMPFER	SILENCIADOR INFERIOR	G16	16
800097881	SILENZIATORE SUPERIORE	UPPER SILENCER	SILENCIEUX SUPERIEUR	OBERER SCHALLDÄMPFER	SILENCIADOR SUPERIOR	G16	12
800097884	GRAFFETTA	CLIP	PLAQUETTE	KLEMME	GRAPA	G08	44
800097886	WORLD DEALER GUIDE	WORLD DEALER GUIDE	WORLD DEALER GUIDE	WELTWEITES HÄNDLERVERZEICHNIS	WORLD DEALER GUIDE	H01	5
800097887	ATTREZZO CUSCINETTO PERNO STERZO	STEERING PIN BEARING TOOL	OUTIL ROULEMENT DIRECTION	WERKZEUG UTIL LENKLAGEZAPFEN	COJINETE PERNO DIRECCION	J02	8
800097888	PIASTRA DI RISCONTRO BASE DI STERZO	STEERING BASE CONTROL PLATE	PLAQUE D'APPUI TE INFERIEUR	AUFLAGEPLATTE LENKBASIS	PLACA DE CONTACTO BASE DIRECCION	J02	9
800097889	ESTRATTORE CUSCINETTO STERZO	STEERING BEARING EXTRACTOR	EXTRACTEUR ROULEMENT DIRECTION	AUSZIEHER LENKLAGER	EXTRACTOR COJINETE DIRECCION	J02	10
800097890	ATTREZZO MONTAGGIO CUSCINETTO STERZO	STEERING BEARING ASSEMBLY TOOL	OUTIL MONT. ROULEMENT DIRECTION	WERKZEUG MONTAGE LENKLAGER	UTIL MONTAJE COJINETE DIRECCION	J02	11
800097899	PIASTRA SX TELAIO	CHASSIS LH PLATE	PLAQUE G. CADRE	LINKE RAHMENPLATTE	PLACA IZQUIERDA BASTIDOR	A01	5
800097900	PIASTRA DX TELAIO	CHASSIS RH PLATE	PLAQUE D. CADRE	RECHTE RAHMENPLATTE	PLACA DERECHA BASTIDOR	A01	6
800097902	POMPA FRENO ANTERIORE	FRONT BRAKE PUMP	MAITRE-CYLINDRE FREIN AVANT	BREMSPUMPE VORDERRADBREMSE	BOMBA FRENO DELANTERO	D03	14
800097903	POMPA FRIZIONE	CLUTCH PUMP	MAITRE-CYLINDRE D'EMBRAYAGE	KUPPLUNGSPUMPE	BOMBA EMBRAGUE	D04	4
800097905	RADIATORE OLIO	OIL COOLER	RADIATEUR D'HUILE	ÖLKÜHLER	RADIADOR ACEITE	G08	33
800097906	GUSCIO INFERIORE AIRBOX	AIRBOX LOWER BEARING	COQUE INFERIEURE AIRBOX	UNTERE AIRBOXSCHALEN	CASCO INFERIOR AIRBOX	E03	6
800097907	GUSCIO SUPERIORE AIRBOX	AIRBOX UPPER BEARING	COQUE SUPERIEURE AIRBOX	OBERE AIRBOXSCHALEN	CASCO SUPERIOR AIRBOX	E03	2
800097908	AIRBOX COMPLETO	AIRBOX ASSEMBLY	AIRBOX COMPLET	AIRBOX KOMPLETT	AIRBOX COMPLETO	E03	1
800097910	GUARNIZIONE	GASKET	JOINT	DICHTUNG	EMPAQUE	E03	12
800097918	VALVOLA (ASPIRAZIONE)	VALVE (INTAKE)	SOUPAPE (ADMISSION)	VENTIL (EINLASS)	VALVULA (ADMISION)	G04	8
800097919	VALVOLA (SCARICO)	VALVE (EXHAUST)	SOUPAPE (ECHAPPEMENT)	VENTIL (AUSLASS)	VALVULA (ESCAPE)	G04	9
800097938	INGRANAGGIO (SCARICO)	GEAR (EXHAUST)	PIGNON (ECHAPPEMENT)	ZAHNRAD (AUSLASS)	ENGRANAJE (ESCAPE)	G05	8
800098021	PISTONE COMPLETO	PISTON ASSEMBLY	PISTON COMPLET	KOLBEN KOMPLETT	PISTON COMPLETO	G03	2
800098023	GRUPPO SEGMENTI PISTONE	PISTON RING ASSEMBLY	GROUPE SEGMENTS PISTON	BAUGRUPPE KOLBENRINGE	CONJUNTO AROS DEL PISTON	G03	3
800098027	SPINOTTO	PISTON PIN	AXE DE PISTON	KOLBENBOLZEN	PERNO DEL PISTON	G03	4
800098028	ANELLO ELASTICO	SNAP RING	CIRCLIP	SPRENGRING	ARO	G03	10
800098149	VITE FISSAGGIO TAMBURO SELETTTORE	SELECTING DRUM CLAMP SCREW	VIS FIXATION TAMBOUR DE SELECTION	BEFESTIGUNGSSCHRAUBE GANGWAHLTROMMEL	TORNILLO FIJACION TAMBOR SELECTOR	G11	21
800098219	VITE M8X95	SCREW M8X95	VIS M8X95	SCHRAUBE M8X95	TORNILLO M8X95	G01	4
800098298	SUPPORTO CENTRALINA SERVIZI	SERVICE POWER UNIT SUPPORT	SUPPORT DE BOITIER DE SERVICES	DIENSTSTEUERUNG- HALTERUNG	SOPORTE CENTRALITA DE SERVICIO	F07	10
800098304	TUBO REGOLATORE	REGULATOR PIPE	TUYAU REGULATEUR	REGLERLEITUNG	TUBO REGULADOR	G12	23
800098305	FILTRO POMPA BENZINA	FUEL PUMP FILTER	FILTRE POMPE A ESSENCE	ENZINPUMPENFILTER	FILTRO BOMBA GASOLINA	G12	13
800098321	PINZA INCLINATA MONTA FASCETTE CLIC	CLIC CLAMPS ASSEMBLY	PLIERS PINCE INCLINEE MONTAGE COLLIERS CLIC	GEBOGENE ZANGE SCHELLEN CLIC	MONTAGE PINZA INCLINADA PARA MONTAR ABRAZADERAS	J01	11

INDICE CODICI / DENOMINAZIONI

CODEX / DESIGNATION INDEX • INDEX CODES / DÉNOMINATIONS

INHALTSVERZEICHNIS CODE • ÍNDICE CÓDIGOS / DENOMINACIONES

Code	Denominazione	Description	Désignation	Bezeichnung	Descripción	Table	N°
800098322	CAVALLOTTO MANUBRIO	HANDLEBAR CLAMP	BRIDE GUIDON	LENKER BEFESTIGUNG	BRIDA MANILLAR	B03	15
800098323	STAFFA	BRACKET	BRIDE	BEFESTIGUNG	BRIDA	G08	24
800098328	SPOILER PARAFANGO	FRONT MUDGUARD	SPOILER GARDE-BOUE	SPOILER VORDERER	SPOILER GUARDBARROS		
	ANTERIORE	SPOILER	AVANT	KOTFLÜGEL	DELANTERO	E01	3
800098329	MANUBRIO	HANDLEBAR	GUIDON	LENKER	MANILLAR	B03	17
800098332	TESTA DI STERZO	STEERING HEAD	TETE SUPERIEUR DIRECTION	LENKKOPF CABEZA	TUBO DIRECCION	B03	12
800098334	PROTEZIONE VENTOLA	COOLER FAN	PROTECTION DU	KÜHLGEBLÄSEABDECKUNG	PROTECCION PARA		
	RADIATORE	PROTECTION	ELECTROVENTILATEUR		ELECTROVENTILADOR	G08	77
800098335	PROTEZIONE LATERALE	SIDE LH WATER COOLER	PROTECTION LATERALE	LINKER SEITEN-	PROTECCION RADIADOR		
	SX RADIATORE ACQUA	PROTECTION	G. DE RADIATEUR D'EAU	KÜHLERABDECKUNG	AGUA LATERAL IZQ.	G08	23
800098336	PROTEZIONE LATERALE	SIDE RH WATER COOLER	PROTECTION LATERALE	RECHTER SEITEN-	PROTECCION RADIADOR		
	DX RADIATORE ACQUA	PROTECTION	D. DE RADIATEUR D'EAU	KÜHLERABDECKUNG	AGUA LATERAL DER.	G08	22
800098404	CUSCINETTO	BEARING	ROULEMENT	LAGER	COJINETE	G01	25
800098405	CUSCINETTO	BEARING	ROULEMENT	LAGER	COJINETE	G01	25
						J03	4
800098440	BASAMENTO COMPLETO	ENGINE BLOCK ASSEMBLY	CARTER MOTEUR COMPLET	KURBELGEHÄUSE KOMPLETT	BASE COMPLETA	G01	1
800098555	PIGNONE CATENA	CHAIN SPROCKET	PIGNON DE CHAINE	KETTENRITZEL	PIÑON CADENA	G10	31
800098670	MOLLA ESTERNA VALVOLA	VALVE OUTER SPRING	RESSORT EXTERIEUR SOUPAPE	ÄUSSERE VENTILFEDER	MUELLE EXTERNO VALVULA	G04	10
800098671	MOLLA INTERNA VALVOLA	VALVE INNER SPRING	RESSORT INTERIEUR SOUPAPE	INNERE VENTILFEDER	MUELLE INTERNO VALVULA	G04	11
800098679	GUARNIZIONE TESTA	HEAD GASKET	JOINT DE CULASSE	ZYLINDERKOPFDICHTUNG	JUNTA CULATA		
	(SP. 1.45)	(THICKNESS 1.45)	(EP. 1.45)	(STÄRKE 1.45)	(SP. 1.45)	G03	8
800098681	PIATTELLO INFERIORE	LOWER CAP	COUPELLE INFERIEURE	UNTERER FEDERTELLER	ASIENTO INFERIOR	G04	13
800098685	TRASMISSIONE	THROTTLE OPENING	TRANSMISSION	GASZUG ÖFFNUNG	TRANSMISION		
	APERTURA GAS	TRANSMISSION	OUVERTURE DES GAZ		ABERTURA GAS	D03	8
800098686	TRASMISSIONE	THROTTLE CLOSING	TRANSMISSION	GASZUG SCHLIESSEN	TRANSMISION		
	CHIUSURA GAS	TRANSMISSION	FERMETURE DES GAZ		CIERRE GAS	D03	9
800098694	PROTEZIONE SUPERIORE	UPPER RH WATER COOLER	PROTECTION SUPERIEUR	OBERER RECHTER	PROTECCION RADIADOR		
	DX RADIATORE ACQUA	PROTECTION	D. DE RADIATEUR D'EAU	KÜHLER ABDECKUNG	AGUA SUPERIOR DER.	G08	19
800098695	PROTEZIONE SUPERIORE	UPPER LH WATER COOLER	PROTECTION SUPERIEUR	OBERER LINKER	PROTECCION RADIADOR		
	SX RADIATORE ACQUA	PROTECTION	G. DE RADIATEUR D'EAU	KÜHLER ABDECKUNG	AGUA SUPERIOR IZQ.	G08	20
800098697	TUBO OLIO FRIZIONE	CLUTCH OIL PIPE	CANALISATION DE LIQUIDE	LEITUNG	TUBO ACEITE EMBRAGUE		
			EMBAYAGE	KUPPLUNGSFLÜSSIGKEIT		D04	7
800098698	STAFFA	BRACKET	BRIDE	BEFESTIGUNG	BRIDA	G08	31
800098704	RETINA FIANCHETTO	AIRBOX RH SIDE NET	GRILLE CACHE D. AIRBOX	RECHTES AIRBOX-SEITENTEIL	REDECILLA LATERAL		
	DX AIRBOX			GITTERNETZ	DERECHO AIRBOX	E04	41
800098705	RETINA FIANCHETTO	AIRBOX LH SIDE NET	GRILLE CACHE G. AIRBOX	LINKES AIRBOX-SEITENTEIL	REDECILLA LATERAL		
	SX AIRBOX			GITTERNETZ	IZQUIERDO AIRBOX	E04	38
800098708	CORONA	GEAR	COURONNE	ZAHNKRANZ	CORONA	C01	28
800098716	PROTEZIONE RADIATORE	WATER COOLER	PROTECTION DE	KÜHLER ABDECKUNG	PROTECCION RADIADOR		
	ACQUA	PROTECTION	RADIATEUR D'EAU		AGUA	G08	11
800098717	STAFFA INTERRUPTORE	IGNITION LOCK SWITCH	BRIDE CONTACTEUR	ZÜNDSCHLOSS-	BRIDA INTERRUPTOR		
	ACCENSIONE	BRACKET	D'ALLUMAGE	BEFESTIGUNG	DE ENCENDIDO	A01	22
800098720	PIASTRINA	PLATE	PLAQUETTE	BLECH	PLACA	E04	34
800098722	SERBATOIO OLIO FRENO	FRONT BRAKE FLUID	RESERVOIR DE LIQUIDE	BREMFLÜSSIGKEITSBEHÄLTER	DEPOSITO ACEITE FRENO		
	ANTERIORE	SUPPLY TANK	FREIN AVANT	VORDERRADBREMSE	DELANTERO	D03	24
800098723	SERBATOIO OLIO POMPA	CLUTCH PUMP OIL TANK	RESERV. FLUIDE MAITRE-	KUPPLUNGSFLÜSSIGKEITS-	DEPOSITO ACEITE BOMBA		
	FRIZIONE		CYLINDRE EMBRAYAGE	BEHÄLTER	EMBRAGUE	D04	18
800098761	SCODELLINO SUPERIORE	UPPER CAP	COUPELLE SUPERIEURE	OBERER FEDERTELLER	TEJUELO SUPERIOR	G04	12
800098769	INGRANAGGIO (ASPIRAZIONE)	GEAR (INTAKE)	PIGNON (ADMISSION)	ZAHNRAD (EINLASS)	ENGRANAJE (ADMISION)	G05	7
800098826	GUARNIZIONE	GASKET	JOINT	DICHTUNG	EMPAQUE	A01	31
800098827	TARGHETTA SX "CRC"	LH "CRC" PLATE	PLAQUETTE "CRC" G.	LINKE "CRC" SCHILD	ETIQUETA "CRC" IZQUIERDA	E04	36
800098828	TARGHETTA DX "CRC"	RH "CRC" PLATE	PLAQUETTE "CRC" D.	RECHTE "CRC" SCHILD	ETIQUETA "CRC" DERECHA	E04	42
800098829	DECAL	DECAL	ADHESIF	AUFKLEBER	CALCOMANIA	E01	13
800098830	DECAL	DECAL	ADHESIF	AUFKLEBER	CALCOMANIA	E05	7
						E05	16
800098834	ANTIVIBRANTE	VIBRATION-DAMPER	ANTI-VIBRATIONS	SCHWINGUNGSDÄMPFER	ANTIVIBRANTE	G08	25

INDICE CODICI / DENOMINAZIONI

 CODEX / DESIGNATION INDEX • INDEX CODES / DÉNOMINATIONS
 INHALTSVERZEICHNIS CODE • ÍNDICE CÓDIGOS / DENOMINACIONES

Code	Denominazione	Description	Désignation	Bezeichnung	Descripción	Table	N°
800098839	SUPPORTO FILTRO OLIO	OIL FILTER SUPPORT	SUPPORT FILTRE A HUILE	ÖLFILTERHALTERUNG	SOPORTE FILTRO ACEITE	G06	26
800098840	VITE SUPPORTO FILTRO OLIO	OIL FILTER SUPPORT SCREW	VIS DE SUPPORT FILTRE A HUILE	ÖLFILTER HALTERUNG SCHRAUBE	TORNILLO PARA SOPORTE FILTRO ACEITE	G06	26
800098841	VITE FASATURA SUPPORTO FILTRO	FILTER SUPPORT TIMING SCREW	VIS DE CALAGE SUPPORT FILTRE	FILTERHALTERUNGSSCHRAUBE PHASENAUSRICHTUNG	TORNILLO PARA FASE SOPORTE FILTRO	G01	20
800098842	RACCORDO TUBI OLIO	OIL PIPES UNION	RACCORD CANALISATIONS D'HUILE	ANSCHLUSS ÖLLEITUNGS	RACOR TUBOS DE ACEITE	G08	41
800098843	PIASTRINA PER CENTRALINA	POWER UNIT PLATE	PLAQUETTE POUR BOITIER	STEUERUNGBLECH	PLACA PARA CENTRALITA	F07	9
800098846	GUARNIZIONE	GASKET	JOINT	DICHTUNG	EMPAQUE	F01	27
800098847	GUARNIZIONE	GASKET	JOINT	DICHTUNG	EMPAQUE	F01	28
800098873	TUBO SFIATO VAPORI OLIO	OIL VAPORS BREATHER PIPE	TUYAU D'EVENT VAPEURS D'HUILE	ÖLDAMPF- ENTLÜFTUNGSLEITUNG	TUBO RESPIRADERO VAPORES DE ACEITE	E03	11
800098943	SERBATOIO ESPANSIONE	EXPANSION TANK	VASE D'EXPANSION	AUSDEHNUNGSGEFÄSS	TANQUE DE EXPANSION	G08	43
800098950	TUBO SCARICO SERBATOIO	FUEL TANK DRAIN PIPE	TUYAU DE VIDANGE RESERVOIR	TANK-ABLASSLEITUNG	TUBO DESCARGA TANQUE	K02	11
800098962	SEPARATORE	SEPARATOR	SEPARATEUR	TRENNVORRICHTUNG	SEPARADOR	D03 D04	30 24
800098964	PROIETTORE ANTERIORE	HEADLIGHT	PROJECTEUR AVANT	SCHEINWERFER	PROYECTOR DELANTERO	F02	1
800098965	PROIETTORE ANTERIORE	HEADLIGHT	PROJECTEUR AVANT	SCHEINWERFER	PROYECTOR DELANTERO	F02	1
800099068	ALBERO A CAMME (ASP.)	CAMSHAFT (INTAKE)	ARBRE A CAMES (ADM.)	NOCKENWELLE (EINLASS)	ARBOL DE LEVAS (ADM.)	G05	5
800099101	COLLETTORE ALIMENTAZIONE	INDUCTION MANIFOLD	COLLECTEUR ALIMENTATION	VERSORGUNGSSTUTZEN	COLECTOR ALIMENTACION	G13	16
800099104	COPERCHIO	COVER	COUVERCLE	DECKEL	TAPA	G01	2
800099105	COPERCHIO	COVER	COUVERCLE	DECKEL	TAPA	G01	38
800099106	COPERCHIO	COVER	COUVERCLE	DECKEL	TAPA	G11	1
800099107	COPERCHIO	COVER	COUVERCLE	DECKEL	TAPA	G11	36
800099110	POMPA ACQUA COMPLETA	WATER PUMP ASSEMBLY	POMPE A EAU COMPLETE	WASSERPUMPE KOMPLETT	BOMBA AGUA COMPLETA	G07	1
800099111	CORPO POMPA ACQUA COMPLETO	WATER PUMP CASING ASSEMBLY	CORPS DE POMPE A EAU COMPLET	WASSERPUMPENGEHÄUSE KOMPLETT	CUERPO BOMBA AGUA COMPLETO	G07	2
800099114	AVVISATORE ACUSTICO	WARNING HOOTER	AVERTISSEUR SONORE	HUPE	CLAXON	F01	11
800099116	SELLA PILOTA	DRIVER'S SADDLE	SELLE PILOTE	FAHRERSITZ	SILLIN PILOTO	E05	19
800099118	SELLA PASSEGGERO	PILLION	SELLE PASSAGER	BEIFAHRSITZ	SILLIN PASAJERO	E05	24
800099120	PORTATARGA	NUMBER PLATE HOLDER	SUPPORT DE PLAQUE	NUMMERNRISCHILDBEFESTIGUNG	PORTAPLACA	A02	11
800099124	BIELLA PER PEDANA	FOOTBOARD SUPPORT	BIELLETTE DE CALE-PIED	STANGE FUSSRASTE	BIELA PARA APOYAPIE	D01 D02	2 2
800099125	CUFFIA	COWLING	PROTECTION	ABDECKUNG	PROTECCION	G08	5
800099126	ANELLO DI TENUTA	GROMMET	BAGUE D'ETANCHEITE	DICHTUNGSRING	RETEN	G06	23
800099127	CONDOTTO MANDATA OLIO	OIL DELIVERY DUCT	CONDUIT REFOULEMENT HUILE	ÖL-ZULEITUNG	CONDUCTO ENVIO ACEITE	G06	15
800099132	PIASTRA SX TELAIO	CHASSIS LH PLATE	PLAQUE G. CADRE	LINKE RAHMENPLATTE	PLACA IZQUIERDA BASTIDOR	A01	5
800099133	DECAL	DECAL	ADHESIF	AUFKLEBER	CALCOMANIA	E02	14
800099134	PANNELLO ANTERIORE DX COMPLETO	FRONT RH SIDE ASSEMBLY	CACHE D. AVANT COMPLETE	RECHTES VORDERE SEITENTEIL KOMPLETT	LATERAL DERECHO DELANTERO COMPLETO	E02	13
800099135	PANNELLO ANTERIORE SX COMPLETO	FRONT LH SIDE ASSEMBLY	CACHE G. AVANT COMPLETE	LINKES VORDERE SEITENTEIL KOMPLETT	LATERAL IZQUIERDO DELANTERO COMPLETO	E01	14
800099136	PROTEZIONE	PROTECTION	PROTECTION	ABDECKUNG	PROTECCION	D02	11
800099141	PIASTRINA	PLATE	PLAQUETTE	BLECH	PLACA	F03	4
800099142	VITE INTERRUPTORE ACCENSIONE	IGNITION LOCK SWITCH SCREW	VIS CONTACTEUR D'ALLUMAGE	SCHRAUBE ZÜNDSCHLOSS	TORNILLO INTERRUPTOR ENCENDIDO	A01	28
800099143	TRASMISSIONE SERRATURA	LOCK TRANSMISSION	TRANSMISSION DE SERRURE	SEILZUG SCHLIESSVORRICHTUNG	TRANSMISION CERRADURA	E05	12
800099159	TUBO MANDATA RADIATORE OLIO	OIL COOLER DELIVERY PIPE	CANALISATION REFOULEMENT RADIATEUR D'HUILE	ÖLKÜHLER ZULEITUNG	TUBO ENVIO RADIADOR ACEITE	G08	39
800099160	TUBO RITORNO RADIATORE OLIO	OIL COOLER RETURN PIPE	CANALISATION DE RETOUR RADIATEUR D'HUILE	ÖLKÜHLER RÜCKLEITUNG	TUBO RETORNO RADIADOR ACEITE	G08	40
800099243	RADIATORE ACQUA	WATER COOLER	RADIATEUR D'EAU	KÜHLER	RADIADOR AGUA	G08	7
800099245	SUPPORTO ELETTOVENTOLA	HEATER FAN SUPPORT	SUPPORT D'ELECTROVENTILATEUR	KÜHLGEBLÄSEHALTERUNG	SOPORTE ELECTROVENTILADOR	G08	2

INDICE CODICI / DENOMINAZIONI

CODEX / DESIGNATION INDEX • INDEX CODES / DÉNOMINATIONS

INHALTSVERZEICHNIS CODE • ÍNDICE CÓDIGOS / DENOMINACIONES

Code	Denominazione	Description	Désignation	Bezeichnung	Descripción	Table	N°
800099247	ELETTOVENTOLA	HEATER FAN	ELECTROVENTILATEUR	KÜHLGEBLÄSE	ELECTROVENTILADOR	G08	1
800099249	ANTIVIBRANTE	VIBRATION-DAMPER	ANTI-VIBRATIONS	SCHWINGUNGSDÄMPFER	ANTIVIBRANTE	G08	12
800099250	TUBO RADIATORE/POMPA	RADIATOR/PUMP PIPE	CANALISATION RADIATEUR/ POMPE	LEITUNG KÜHLER/ PUMPE	TUBO RADIADOR /BOMBA	G08	56
800099251	SUPPORTO	SUPPORT	SUPPORT	HALTERUNG	SOPORTE	F01	5
800099263	TELAJETTO POSTERIORE	REAR FRAME	CADRE ARRIERE	HINTERER KLEINER RAHMEN	CHASIS TRASERO	A02	1
800099267	GRUPPO PRINCIPALE CAVI	MAIN CABLES SET	FAISCEAU PRINCIPAL	HAUPTKABELSTRANG	GRUPO CABLES PRINCIPALES	F01	34
800099268	CAVO TELERUTTORE/ MOTORINO AVVIAMENTO	BATTERY/STARTER CABLE	CABLE TELERUPTEUR/ DEMARREUR	KABEL BATTERIE/ ANLASSERMOTOR	CABLE TELERRUPTOR/ MOTOR DE ARRANQUE	F03	1
800099269	CAVO TELERUTTORE/ BATTERIA	BATTERY/ELECTROMAGNETIC SWITCH CABLE	CABLE TELERUPTEUR/ BATTERIE	KABEL BATTERIE/ FERNRELAIS	CABLE TELERRUPTOR/ BATERIA	F05	10
800099270	CENTRALINA INIEZIONE	INJECTION POWER UNIT	BOITIER DE CONTROLE INIECTION	EINSPRITZ-STEUERUNG	CENTRALITA INYECCION	F07	1
800099272	EPROM	EPROM	EPROM	EPROM	EPROM	F07	2
800099276	PIASTRINA	PLATE	PLAQUETTE	BLECH	PLACA	F05	5
800099277	SUPPORTO PROIETTORE	HEADLIGHT SUPPORT	SUPPORT DE PROJECTEUR	SCHWEINWERFER HALTERUNG	SOPORTE PROYECTOR	F01	26
800099278	ROSETTA	WASHER	RONDELLE	UNTERLEGSCHIBE	ARANDELA	G08	17
800099281	PIASTRINA	PLATE	PLAQUETTE	BLECH	PLACA	F01	13
800099282	PIASTRINA	PLATE	PLAQUETTE	BLECH	PLACA	F01	31
800099283	COPRI INTERRUPTORE ACCENSIONE	IGNITION LOCK SWITCH COVER	CACHE CONTACTEUR D'ALLUMAGE	ZÜNDSCHLOSS- ABDECKUNG	CUBRE INTERRUPTOR DE ENCENDIDO	A01	29
800099284	FIANCHETTO DX AIRBOX	AIRBOX RH SIDE	CACHE D. AIRBOX	RECHTES AIRBOX-SEITENTEIL	LATERAL DERECHO AIRBOX	E04	40
800099285	FIANCHETTO SX AIRBOX	AIRBOX LH SIDE	CACHE G. AIRBOX	LINKES AIRBOX-SEITENTEIL	LATERAL IZQUIERDO AIRBOX	E04	37
800099286	FIANCHETTO DX CODINO	TAIL RH SIDE FAIRING	CACHE D. COQUE ARRIERE	RECHTE HECKTEIL- VERKLEIDUNG	LATERAL DERECHO COLA	E05	14
800099287	FIANCHETTO SX CODINO	TAIL LH SIDE FAIRING	CACHE G. COQUE ARRIERE	LINKE HECKTEIL- VERKLEIDUNG	LATERAL IZQUIERDO COLA	E05	5
800099288	CODINO	TAIL	COQUE ARRIERE	HECKTEIL	COLA	E05	1
800099289	PERNO	PIN	AXE	WELLE	PERNO	E02	3
						E02	8
800099290	MOLLA	SPRING	RESSORT	FEDER	MUELLE	E02	5
						E02	10
800099291	DADO M8	NUT M8	ECROU M8	MUTTER M8	TUERCA M8	E02	6
						E02	11
800099292	TAPPO DX	RH PLUG	BOUCHON D.	RECHTER VERSCHLUSS	TAPON DERECHO	E02	7
800099293	RETINA	NET	GRILLE	GITTERNETZ	REDECILLA	G08	35
800099294	PROTEZIONE RADIATORE OLIO	OIL COOLER PROTECTION	PROTECTION DE RADIATEUR D'HUILE	ÖLKÜHLER ABDECKUNG	PROTECCION RADIADOR ACEITE	G08	34
800099322	TAMPONE	PAD	TAMPON	PUFFER	TAPON	G08	36
800099323	COPERTURA CRUSCOTTO	DASHBOARD COVER	COUVRE-COMBINE DE BORD	ARAMTURENBRETTDECKEL	TAPA TABLERO	E01	11
800099324	PROTEZIONE SERBATOIO	FUEL TANK PROTECTION	PROTECTION DERESERVOIR	BENZINTANK ABDECKUNG	PROTECCION PARA DEPOSITO	E04	14
800099325	SERBATOIO BENZINA	FUEL TANK	RESERVOIR D'ESSENCE	BENZINTANK	DEPOSITO GASOLINA	E04	6
800099326	ANTIVIBRANTE	VIBRATION-DAMPER	ANTI-VIBRATIONS	SCHWINGUNGSDÄMPFER	ANTIVIBRANTE	E04	31
800099327	STAFFA SERBATOIO	FUEL TANK BRACKET	BRIDE DE RESERVOIR	BEFESTIGUNG BENZINTANK	BRIDA DEPOSITO GASOLIN	A01	25
800099331	FILTRO ARIA	AIR FILTER	FILTRE A AIR	LUFTFILTER	FILTRO AIRE	E03	13
800099336	MOLLETTA DX PER AIRBOX	RH SPRING FOR AIRBOX	PINCE D. POUR AIRBOX	RECHTE KLAMMER FÜR AIRBOX	NUELE DER. PARA AIRBOX	E03	16
800099337	MOLLETTA SX PER AIRBOX	LH SPRING FOR AIRBOX	PINCE G. POUR AIRBOX	LINKE KLAMMER FÜR AIRBOX	NUELE IZQ. PARA AIRBOX	E03	4
800099339	CONDOTTO ARIA SX	LH AIR DUCT	CONDUIT AIRE G.	LINKER LUFTSTUTZEN	CONDUCTO AIRE IZQUIERDO	E03	3
800099340	CONDOTTO ARIA DX	RH AIR DUCT	CONDUIT AIRE D.	RECHTER LUFTSTUTZEN	CONDUCTO AIRE DERECHO	E03	14
800099341	PIASTRINA	PLATE	PLAQUETTE	BLECH	PLACA	D02	37
800099343	COLLETTORE USCITA CILINDRI 1-2	CYLINDERS 1-2 OUTPUT MANIFOLD	COLLECTEUR ECH. CYLINDRES 1-2	ABGASKRÜMMER ZYLLINDER 1-2	COLACTOR SALIDA CILINDROS 1-2	G16	2
800099344	COLLETTORE USCITA CILINDRI 3-4	CYLINDERS 3-4 OUTPUT MANIFOLD	COLLECTEUR ECH. CYLINDRES 3-4	ABGASKRÜMMER ZYLLINDER 3-4	COLACTOR SALIDA CILINDROS 3-4	G16	3

INDICE CODICI / DENOMINAZIONI

 CODEX / DESIGNATION INDEX • INDEX CODES / DÉNOMINATIONS
 INHALTSVERZEICHNIS CODE • ÍNDICE CÓDIGOS / DENOMINACIONES

Code	Denominazione	Description	Désignation	Bezeichnung	Descripción	Table	N°
800099345	COMPENSATORE DI SCARICO	EXHAUST COMPENSATOR	COMPENSATEUR D'ÉCHAPPEMENT	AUSPUFFKOMPENSATOR	COMPENSADOR DE ESCAPE	G16	10
800099346	SUPPORTO COMPENSATORE	COMPENSATOR SUPPORT	SUPPORT DU COMPENSATEUR	KOMPENSATOR HALTERUNG	SOPORTE COMPENSADOR	G16	11
800099347	PIASTRINA	PLATE	PLAQUETTE	BLECH	PLACA	G16	20
800099348	BUSSOLA	BUSH	BAGUE	HÜLSE	CASQUILLO	G16	25
800099349	PROTEZIONE SUPERIORE	UPPER PROTECTION	PROTECTION SUPERIEUR	OBERE ABDECKUNG	PROTECCION SUPERIOR	G16	17
800099351	BORSA ATTREZZI COMPLETA	TOOLS KIT	TROUSSE A OUTILS COMPLETE	WERKZEUGTASCHE KOMPLETT	BOLSA HERRAMIENTAS COMPLETA	H01	2
800099358	LIBRETTO USO E MANUTENZIONE (I)	USE AND MAINTENANCE HANDBOOK (I)	LIVRET UTILISATION ET ENTRETIEN (I)	BEDIENUNGSANLEITUNG (I)	MANUAL DE MANTENIMIENTO (I)	H01	6
800099359	CATALOGO RICAMBI	SPARE PARTS CATALOGUE	CATALOGUE PIECES DETACHEES	ERSATZTEILKATALOG	CATALOGO RECAMBIO	H01	1
800099360	MANUALE OFFICINA MOTOTELAIO (I)	ENGINE OVERHAUL HANDBOOK (I)	MANUEL D'ATELIER MECANIQUE GEN. (I)	WERKSTATT HANDBUCH MOTORRADRAHMEN (I)	MANUAL PARA TALLERES VEHICULO (I)	H01	10
800099361	OWNER'S MANUAL (USA)	OWNER'S MANUAL (USA)	OWNER'S MANUAL (USA)	OWNER'S MANUAL (USA)	OWNER'S MANUAL (USA)	H01	6
800099362	TELO COPRIMOTO	MOTORCYCLE COVER	BACHE ABDECKPLANE	FÜR MOTORRAD	LONA CUBREMOTO	H01	9
800099376	DISTANZIALE	SPACER	ENTRETOISE	ABSTANDHALTER	DISTANCIADOR	F01	19
800099378	TARGHETTA "EMISSIONI"	"EMISSIONS" DATA PLATE	PLAQUETTE "EMISSIONS"	SCHILD "ABGASWERTE"	ETIQUETA "EMISIONES"	K01	6
800099379	TARGHETTA "RUMORE"	"NOISE" DATA PLATE	PLAQUETTE "BRUIT"	SCHILD "GERÄUSCHBELASTUNG"	ETIQUETA "RUIDOS"	K01	7
800099383	GUARNIZIONE SCARICO	EXHAUST GASKET	JOINT D'ÉCHAPPEMENT	AUSPUFFDICHTUNG	EMPAQUE ESCAPE	G16	1
800099391	GUIDA CAVI	CABLES GUIDE	GUIDE DES CABLES	KABELFÜHRUNG	GUIAS DE CABLES	F06	10
800099397	TAMPONE	PAD	TAMPON	PUFFER	TAPON	A01	27
800099398	TAMPONE	PAD	TAMPON	PUFFER	TAPON	A01	26
800099401	BUSSOLA	BUSH	BAGUE	HÜLSE	CASQUILLO	E04	26
800099403	PROTEZIONE INFERIORE	LOWER PROTECTION	PROTECTION INFERIEUR	UNTERE ABDECKUNG	PROTECCION INFERIOR	G16	15
800099405	DECAL	DECAL	ADHESIF	AUFKLEBER	CALCOMANIA	F01	29
800099406	CHIUSURA POSTERIORE DX CILINDRI	CYLINDERS REAR RH COVER	COUVERCLE ARRIERE D. DE CYLINDRES	HINTERE RECHTE ZYLINDERDECKEL	TAPA TRASERA DERECHA CILINDROS	E02	17
800099407	CHIUSURA POSTERIORE SX CILINDRI	CYLINDERS REAR LH COVER	COUVERCLE ARRIERE G. DE CYLINDRES	HINTERE LINKE ZYLINDERDECKEL	TAPA TRASERA IZQUIERDA CILINDROS	E01	18
800099410	DECAL	DECAL	ADHESIF	AUFKLEBER	CALCOMANIA	B03	14
800099419	ANTIVIBRANTE	VIBRATION-DAMPER	ANTI-VIBRATIONS	SCHWINGUNGSDÄMPFER	ANTIVIBRANTE	A01	35
800099426	CAPPUCCIO	CAP	CAPUCHON	KAPPE	CAPUCHON	A01	23
800099428	COPRI INTERRUPTORE ACCENSIONE	IGNITION LOCK SWITCH COVER	CACHE CONTACTEUR D'ALLUMAGE	ZÜNDSCHLOSS- ABDECKUNG	CUBRE INTERRUPTOR DE ENCENDIDO	A01	29
800099429	FIANCHETTO SX AIRBOX	AIRBOX LH SIDE	CACHE G. AIRBOX	LINKES AIRBOX-SEITENTEIL	LATERAL IZQUIERDO AIRBOX	E04	37
800099430	FIANCHETTO DX AIRBOX	AIRBOX RH SIDE	CACHE D. AIRBOX	RECHTES AIRBOX-SEITENTEIL	LATERAL DERECHO AIRBOX	E04	40
800099431	CODINO	TAIL	COQUE ARRIERE	HECKTEIL	COLA	E05	1
800099432	PROTEZIONE RADIATORE OLIO	OIL COOLER PROTECTION	PROTECTION DE RADIATEUR D'HUILE	ÖLKÜHLER ABDECKUNG	PROTECCION RADIADOR ACEITE	G08	34
800099433	COPERTURA CRUSCOTTO	DASHBOARD COVER	COUVRE-COMBINE DE BORD	ARAMTURENBRETTDECKEL	TAPA TABLERO	E01	11
800099447	SUPPORTO PEDANA ANTERIORE SX	LH FRONT FOOTBOARD SUPPORT	SUPPORT DE CALE-PIED AVANT GAUCHE	HALTERUNG VORDERE LINKE FUSSRASTE	SOPORTE ESTRIBO APOYAPIE DEL. IZQUIERDO	D01	21
800099448	SUPPORTO PEDANA ANTERIORE DX	RH FRONT FOOTBOARD SUPPORT	SUPPORT DE CALE-PIED AVANT DROITE	HALTERUNG VORDERE RECHTE FUSSRASTE	SOPORTE ESTRIBO APOYAPIE DEL. DERECHO	D02	40
800099453	PIASTRINA	PLATE	PLAQUETTE	BLECH	PLACA	G08	46
800099476	VITE M8X130	SCREW M8X130	VIS M8X130	SCHRAUBE M8X130	TORNILLO M8X130	G01	7
800099812	PIASTRINA	PLATE	PLAQUETTE	BLECH	PLACA	G15	17
8000A0105	COPERCHIO TESTA	HEAD COVER	COUVRE-CULASSE	ZYLINDERKOPFDECKEL	TAPA CULATA	G04	16
8000A0120	CATENA DI DISTRIBUZIONE CHIUUSA	CLOSED TIMING CHAIN	CHAINE DISTRIBUTION FERMEE	VENTILSTEUERKETTE GESCHLOSSEN	CADENA DISTRIBUCION CERRADA	G05	6
8000A0370	BUSSOLA	BUSH	BAGUE	HÜLSE	BUJE	G10	5
						G10	10
						G10	17
						G10	23
						G10	28

INDICE CODICI / DENOMINAZIONI

CODEX / DESIGNATION INDEX • INDEX CODES / DÉNOMINATIONS

INHALTSVERZEICHNIS CODE • ÍNDICE CÓDIGOS / DENOMINACIONES

Code	Denominazione	Description	Désignation	Bezeichnung	Descripción	Table	N°
8000A0515	GOMMINO	RUBBER COVER	CAOUTCHOUC	GUMMI	GOMA	G15	16
8000A0711	BOBINA COMPLETA	IGNITION COIL ASSEMBLY	BOBINE D'ALLUMAGE COMPLETE	ZÜNDSPULEN KOMPLETT	BOBINA COMPLETA	G15	15
8000A0817	ANELLO DI TENUTA	GROMMET	BAGUE D'ETANCHEITE	DICHTUNGSRING	RETEN	B04	27
						B05	27
8000A0826	ANELLO DI TENUTA	GROMMET	BAGUE D'ETANCHEITE	DICHTUNGSRING	RETEN	B04	5
						B05	5
8000A0841	VITE M12X30	SCREW M12X30	VIS M12X30	SCHRAUBE M12X30	TORNILLO M12X30	B04	1
						B05	1
8000A0901	ROSETTA	WASHER	RONDELLE	UNTERLEGSCHIEBE	ARANDELA	G11	14
8000A0903	TAMPONE PER SERBATOIO	FUEL TANK PAD	TAMPON DE RESERVOIR	BENZINTANKPUFFER	TAPON DEPOSITO GASOLINA	E04	35
8000A0920	COMMUTATORE DX	RH SWITCH	COMODO D.	RECHTER WECHSELSCHALTER	CONMUTADOR DER.	D03	16
8000A0922	COMMUTATORE SX	LH SWITCH	COMODO G.	LINKER WECHSELSCHALTER	CONMUTADOR IZQUIERDO	D04	6
8000A0923	COPERCHIO CENTRALINA	SERVICE POWER UNIT COVER	COUVERCLE DU BOITIER	STEUERUNGDECKEL	TAPA CENTRALITA	F07	12
8000A0924	DECAL	DECAL	ADHESIF	AUFKLEBER	CALCOMANIA	F07	13
8000A0965	SUPPORTO SERBATOIO BENZINA	FUEL TANK SUPPORT	SUPPORT DU RESERVOIR D'ESSENCE	BENZINTANK-HALTERUNG	SOPORTE DEPOSITO GASOLINA	J04	2
8000A0973	ROSETTA	WASHER	RONDELLE	UNTERLEGSCHIEBE	ARANDELA	G10	4
						G10	9
8000A0975	ANELLO ELASTICO	SNAP RING	CIRCLIP	SPRENGRING	ANILLO ELASTICO	G10	7
						G10	39
8000A0980	ALBERO SECONDARIO	TRANSMISSION SHAFT	ARBRE SECONDAIRE	VORGELEGEWELLE	ARBOL SECUNDARIO	G10	16
8000A0982	ROSETTA	WASHER	RONDELLE	UNTERLEGSCHIEBE	ARANDELA	G10	19
						G10	22
8000A0987	ROSETTA	WASHER	RONDELLE	UNTERLEGSCHIEBE	ARANDELA	G10	27
						G10	40
8000A0990	ANELLO ELASTICO	SNAP RING	CIRCLIP	SPRENGRING	ANILLO ELASTICO	G10	20
8000A1009	TUBO SERBATOIO/ POMPA FRENO	FUEL TANK/BRAKE PUMP PIPE	CANALISATION RESERVOIR/ MAITRE-CYLINDRE	LEITUNG BREMSFLÜSSIGKEITS- BEHÄLTER/ BREMSPUMPE	TUBO TANQUE/ BOMBA FRENO	D02	34
8000A1038	PARAFANGO- PORTABATTERIA	MUDGUARD- BATTERY SUPPORT	GARDE-BOUE/ PORTE-BATTERIE	KOTFLÜGEL- BATTERIEHALTERUNG	GUARDABARROS- PORTABATERIA	A02	5
8000A1039	ATTREZZO PARAPOLVERE E PARAOLIO	DUST COVER AND OIL SEAL TOOL	OUTIL JOINT-POUSSIÈRE ET JOINT A LEVRE	WERKZEUG STAUBSCHUTZRINGE UND ÖLDICHRINGE ACEITE	UTIL GUARDAPOLVO Y RETEN DE	J01	13
8000A1040	ROSETTA	WASHER	RONDELLE	UNTERLEGSCHIEBE	ARANDELA	E02	4
8000A1072	ALBERO SECONDARIO	TRANSMISSION SHAFT	ARBRE SECONDAIRE	VORGELEGEWELLE	ARBOL SECUNDARIO	G10	16
8000A1079	PIASTRINA	PLATE	PLAQUETTE	BLECH	PLACA	A02	34
8000A1086	CUSCINETTO	BEARING	ROULEMENT	LAGER	COJINETE	G11	4
8000A1087	CUSCINETTO	BEARING	ROULEMENT	LAGER	COJINETE	G01	30
						J03	3
8000A1234	ROSETTA	WASHER	RONDELLE	UNTERLEGSCHIEBE	ARANDELA	G10	38
8000A1239	MOLLA	SPRING	RESSORT	FEDER	MUELLE	G16	6
						G16	13
8000A1245	DECAL	DECAL	ADHESIF	AUFKLEBER	CALCOMANIA	E02	14
8000A1262	PANNELLO ANTERIORE DX COMPLETO	FRONT RH SIDE ASSEMBLY	CACHE D. AVANT COMPLETE	RECHTES VORDERE SEITENTEIL KOMPLETT	LATERAL DERECHO DELANTERO COMPLETO	E02	13
8000A1295	VITE PER SEPARATORE	SEPARATOR SCREW	VIS DE SEPARATEUR	SCHRAUBE FÜR TRENNVORRICHTUNG	TORNILLO PARA SEPARADOR	D03	31
						D04	25
8000A1400	SONDA RISERVA CARBURANTE	LOW FUEL PROBE	SONDE DE RESERVE CARBURANT	BENZINSTANDGEBER RESERVE	CAPTADOR RESERVA COMBUSTIBLE	G12	7
8000A1402	CONTRAPPESO	COUNTERWEIGHT	CONTREPOIDS	GEGENGEWICHT	CONTRAPESO	D03	11
						D04	1
8000A1409	GUIDA TRASMISSIONE GAS	THROTTLE TRANSMISSION GUIDE	GUIDE DE TRANSMISSION DES GAZ	GASZUG FÜHRUNG	GUIAS TRANSMISION GAS	G08	15
8000A1432	ATTREZZO MONTAGGIO PISTONI	PISTON ASSEMBLY TOOL	OUTIL MONTAGE PISTONS	WERKZEUG KOLBENMONTAGE	UTIL MONTAJE DEL PISTON	J03	23

INDICE CODICI / DENOMINAZIONI

 CODEX / DESIGNATION INDEX • INDEX CODES / DÉNOMINATIONS
 INHALTSVERZEICHNIS CODE • ÍNDICE CÓDIGOS / DENOMINACIONES

Code	Denominazione	Description	Désignation	Bezeichnung	Descripción	Table	N°
8000A1440	KIT INIETTORE	INJECTOR KIT	KIT INJECTEUR	UMBAUSATZ EINSPRITZDÜSE	KIT INYECTOR	G13	10
8000A1442	KIT COLLETTORE BENZINA	FEED MANIFOLD KIT	KIT COLLECTEUR D'ESSENCE	UMBAUSATZ VERSORGUNGSSTUTZEN	KIT COLECTOR DE GASOLINA	G13	15
8000A1453	STAFFA BOWDEN	BOWDEN BRACKET	BRIDE BOWDEN	BOWDEN BEFESTIGUNG	BRIDA BOWDEN	G13	23
8000A1455	KIT VITE REGOLAZIONE	ADJUSTMENT SCREW KIT	KIT VIS DE REGLAGE	UMBAUSATZ EINSTELLUNGSSCHRAUBE	KIT TORNILLO DE REGULACION	G13	24
8000A1487	TARGHETTA PNEUMATICI	TYRES DATA PLATE	PLAQUETTE PNEUMATIQUES	SCHILD REIFEN	ETIQUETA NEUMATICOS	A01	34
8000A1488	FASCETTA CON VITE	CLAMP WITH SCREW	COLLIER AVEC VIS	SHELLE MIT SCHRAUBE	CINTA CON TORNILLO	G06	36
8000A1500	GAMBA DX COMPLETA	RH LEG ASSEMBLY	BRAS D. COMPLET	RECHTES BEIN KOMPLETT	PATA HORQUILLA DERECHA COMPLETA	B03	1
8000A1501	GAMBA SX COMPLETA	LH LEG ASSEMBLY	BRAS G. COMPLET	LINKES BEIN KOMPLETT	PATA HORQUILLA IZQUIERDA COMPLETA	B03	2
8000A1558	TUBO RITORNO BENZINA	FUEL RETURN PIPE	CANALISATION DE RETOUR ESSENCE	BENZIN-RÜCKLEITUNG	TUBO RETORNO GASOLINA	G13	8
8000A1592	MANUALE OFFICINA MOTORE (I)	ENGINE OVERHAUL HANDBOOK (I)	MANUEL D'ATELIER MOTEUR (I)	WERKSTATTHANDBUCH MOTOR (I)	MANUAL PARA TALLERES MOTOR (I)	H01	11
8000A1680	PIASTRINA SUPPORTO CANISTER	CANISTER SUPPORT PLATE	PLAQUETTE DE SUPPORT DU CANISTER	CARBONKANISTER- HALTERUNG	PLACA DE SOPORTE CANISTER	K02	6
8000A1681	PIASTRINA ANTERIORE CANISTER	FRONT CANISTER PLATE	PLAQUETTE AVANT DU CANISTER	VORDERER CARBON- KANISTERBLECH	PLACA DELANTERA CANISTER	K02	2
8000A1682	PIASTRINA POSTERIORE CANISTER	REAR CANISTER PLATE	PLAQUETTE ARRIERE DU CANISTER	HINTERER CARBON- KANISTERBLECH	PLACA TRASERA CANISTER	K02	3
8000A1763	TAPPO SX	LH PLUG	BOUCHON G.	LINKER VERSCHLUSS	TAPON IZQUIERDO	E02	12
8000A1770	CORPO PROIETTORE	HEADLIGHT CASING	CORPS DE PROJECTEUR	SCHWEINWERFERGEHÄUSE	CUERPO PROYECTOR	F02	2
8000A1771	GRUPPO OTTICO	OPTICAL UNIT	GROUPE OPTIQUE	OPTISCHE EINHEIT	GRUPO OPTICO	F02	4
8000A1772	CAVI PROIETTORE ANTERIORE	HEADLIGHT CABLES	CABLES DU PROJECTEUR AVANT	SCHWEINWERFERKABEL	CABLES PROYECTOR DELANTERO	F02	5
8000A1773	LAMPADA	BULB	AMPOULE	LAMPE	LAMPARA	F02	7
8000A1774	LAMPADA	BULB	AMPOULE	LAMPE	LAMPARA	F02	7
8000A1763	TAPPO SX	LH PLUG	BOUCHON G.	LINKER VERSCHLUSS	TAPON IZQUIERDO	E02	12
8000A1785	GRUPPO OTTICO	OPTICAL UNIT	GROUPE OPTIQUE	OPTISCHE EINHEIT	GRUPO OPTICO	F02	4
8000A1786	GRUPPO OTTICO	OPTICAL UNIT	GROUPE OPTIQUE	OPTISCHE EINHEIT	GRUPO OPTICO	F02	4
8000A1825	FLANGIA PORTATARGA/ CATADIOTTRI	NUMBER PLATE HOLDER/ RETROREFLECTORS FLANGE	FLASQUE SUPPORT DE PLAQUE/REFLECTEURS	BEFESTIGUNGSFLANSCH NUMMERN SCHILDBEFESTI- GUNG/KATZENAUGE	BRIDA PORTAPLACA/ CATAFARROS	K01	10
8000A1839	BICCHIERINO PER VALVOLA	VALVE CUP	GODET POUR SOUPAPE	VENTILBECHER	TAZA PARA VALVULA	G05	20
8000A1857	STELO SX COMPLETO	LH STEM ASSEMBLY	TUBE G. COMPLET	LINKER SCHAFT KOMPLETT	VASTAGO IZQ. COMPLETO	B05	4
8000A1858	STELO DX COMPLETO	RH STEM ASSEMBLY	TUBE D. COMPLET	RECHTER SCHAFT KOMPLETT	VASTAGO DER. COMPLETO	B04	4
8000A1859	GRUPPO VITE DI REGOLAZIONE	ADJUSTING SCREW SET	GROUPE VIS DE REGLAGE	EINSTELLUNGSSCHRAUBE EINHEIT	GRUPO TORNILLO DE REGULACIÓN	B04 B05	7 7
8000A1860	BOCCOLA	BUSH	BAGUE	HÜLSE	CASQUILLO	B04 B05	8 8
8000A1861	CARTUCCIA	CARTRIDGE	CARTOUCHE	PATRONE	CARTUCHO	B04 B05	15 15
8000A1862	ASSIEME PACCO COMPRESSIONE	COMPRESSION PACK ASSEMBLY	ENSEMBLE PAQUET COMPRESSION	BAUGRUPPE KOMPRESSIONSPAKET	CONJUNTO PAQUETE COMPRESION	B04 B05	18 18
8000A1863	PARAPOLVERE	DUST COVER	JOINT-POUSSIERE	STAUBSCHUTZRING	GUARDAPOLVO	B04 B05	19 19
8000A1864	PIEDINO DX COMPLETO	RH FOOT ASSEMBLY	BASE D. COMPLETE	RECHTER FUSS KOMPLETT	PIE' DERECHO COMPLETO	B04	20
8000A1865	PIEDINO SX COMPLETO	LH FOOT ASSEMBLY	BASE G. COMPLETE	LINKER FUSS KOMPLETT	PIE' IZQUIERDO COMPLETO	B05	20
8000A1866	DISTANZIALE E BOCCOLA	SPACER AND BUSH	ENTRETOISE ET BAGUE	ABSTANDHALTER UND HÜLSE	DISTANCIADOR Y CASQUILLO	B04 B05	21 21
8000A1867	ROSETTA	WASHER	RONDELLE	UNTERLEGSCHEIBE	ARANDELA	B04 B05	23 23

INDICE CODICI / DENOMINAZIONI

CODEX / DESIGNATION INDEX • INDEX CODES / DÉNOMINATIONS

INHALTSVERZEICHNIS CODE • ÍNDICE CÓDIGOS / DENOMINACIONES

Code	Denominazione	Description	Désignation	Bezeichnung	Descripción	Table	N°
8000A1868	DISTANZIALE	SPACER	ENTRETOISE	ABSTANDHALTER	DISTANCIADOR	B04	24
						B05	24
8000A1869	FODERO	SLEEVE	FOURREAU	HÜLSE	ENVOLTURA	B04	25
						B05	25
8000A1870	ANELLO DI TENUTA	GROMMET	BAGUE D'ETANCHEITE	DICHTUNGSRING	RETEN	B04	26
						B05	26
8000A1871	TAPPO COMPLETO	PLUG ASSEMBLY	BOUCHON COMPLET	VERSCHLUSS KOMPLETT	TAPON COMPLETO	B04	28
						B05	28
8000A1872	DECAL	DECAL	ADHESIF	AUFKLEBER	CALCOMANIA	B04	29
						B05	29
8000A1873	BUSSOLA	BUSH	BAGUE	HÜLSE	CASQUILLO	F06	6
8000A1874	ATTREZZATURA SUPPORTO SERBATOIO BENZINA	FUEL TANK SUPPORT TOOL	OUTIL SUPPORT DU RESERVOIR D'ESSENCE	WERKZEUG BENZINTANK- HALTERUNG	UTIL SOPORTE DEPOSITO GASOLINA	J04	1
8000A1875	TUBO RITORNO BENZINA	FUEL RETURN PIPE	CANALISATION DE RETOUR ESSENCE	BENZIN-RÜCKLEITUNG	TUBO RETORNO GASOLINA	J04	5
8000A1876	CABLAGGIO ELETTRICO	ELECTRIC CABLES	ÉLECTRIQUE CABLES	ELEKTRISCHE GASZÜGE	CABLES ELÉCTRICOS	J04	3
8000A1878	CHIAVE SILENT-BLOCK AIRBOX	AIRBOX VIBRATION- DAMPERS SPANNER	CLE ANTI-VIBRATIONS DE AIRBOX	AIRBOX SCHWINGUNGS- DÄMPFER SCHLÜSSEL	LLAVE ANTIVIBRANTES DE AIRBOX	J02	12
8000A1952	BUSSOLA	BUSH	BAGUE	HÜLSE	CASQUILLO	G16	28
8000A1953	PERNO PER ALBERO DI CENTRAGGIO	PIN FOR CENTERING SHAFT	AXE POUR ARBRE DE CENTRAGE	BOLZEN FÜR ZENTRIERWELLE	PERNO PARA EJE DE CENTRAJE	J01	8
8000A1956	INGRANAGGIO 6°	6th GEAR	PIGNON 6°	ZAHNRAD 6. GANG	ENGRANAJE 6°	G10	11
8000A1957	INGRANAGGIO 6°	6th GEAR	PIGNON 6°	ZAHNRAD 6. GANG	ENGRANAJE 6°	G10	21
8000A2039	MOLLA	SPRING	RESSORT	FEDER	MUELLE	B04	22
						B05	22
8000A2180	ANELLO DI TENUTA	GROMMET	BAGUE D'ETANCHEITE	DICHTUNGSRING	RETEN	D03	38
8000A2181	ANELLO DI TENUTA	GROMMET	BAGUE D'ETANCHEITE	DICHTUNGSRING	RETEN	D03	37
8000A2279	ANTIVIBRANTE	VIBRATION-DAMPER	ANTI-VIBRATIONS	SCHWINGUNGSDÄMPFER	ANTIVIBRANTE	F06	26
8000A2280	ATTREZZO CHIUSURA CATENA DISTRIBUZIONE	TIMING CHAIN MOUNTING TOOL	OUTIL MONTAJE CHAINE DISTRIBUTION	WERKZEUG VENTIL- STEUERKETTENBAU	UTIL MONTAJE CADENA DE LA DISTRIBUCION	J03	20
8000A2281	ATTREZZO APERTURA CATENA DISTRIBUZIONE	TIMING CHAIN CUTTING TOOL	OUTIL COUPE CHAINE DISTRIBUTION	WERKZEUG VENTIL- STEUERKETTENSCHNITT	UTIL CORTE CADENA DE LA DISTRIBUCION	J03	21
8000A2306	GUIDA VALVOLA COMPLETO	VALVE GUIDE ASSEMBLY	GUIDE DE SOUPAPE COMPLETE	VENTILFÜHRUNG KOMPLETT	GUIA VALVOLA COMPLETA	G04	25
8000A2318	CUSCINETTO	BEARING	ROULEMENT	LAGER	COJINETE	G11	3
8000A2319	DISTANZIALE	SPACER	ENTRETOISE	ABSTANDHALTER	DISTANCIADOR	G10	32
8000A2385	TAMPONE MONTAGGIO GUIDA	GUIDE ASSEMBLY PAD	TAMPON MONTAGE GUIDE	PUFFER MONTAGE FÜHRUNG	TAPON MONTAJE GUIAS	J03	18
8000A2530	ALBERO PRIMARIO	MAIN SHAFT	ARBRE PRIMAIRE	HAUPTANTRIEBSWELLE	ARBOL PRIMARIO	G10	1
8000A2531	ALBERO SECONDARIO	TRANSMISSION SHAFT	ARBRE SECONDAIRE	VORGELEGEWELLE	ARBOL SECUNDARIO	G10	15
8000A2532	INGRANAGGIO 6°	6th GEAR	PIGNON 6°	ZAHNRAD 6. GANG	ENGRANAJE 6°	G10	11
8000A2625	BROCCIA PER GUIDA VALVOLE	BROACH FOR VALVE GUIDE	BROCHE POUR GUIDE DE SOUPAPE	VENTILFÜHRUNGGRÄUMEN	MANDRIL PARA GUIA VALVOLA	J03	22
8000A2629	ALBERO PRIMARIO COMPLETO	MAIN SHAFT ASSEMBLY	ARBRE PRIMAIRE COMPLET	HAUPTANTRIEBSWELLE KOMPLETT	ARBOL PRIMARIO COMPLETO	G10	2
8000A2630	INGRANAGGIO 5°	5th GEAR	PIGNON 5°	ZAHNRAD 5. GANG	ENGRANAJE 5°	G10	6
8000A2631	INGRANAGGIO 3°-4°	3rd-4th GEAR	PIGNON 3°-4°	ZAHNRAD 3. GANG-4. GANG	ENGRANAJE 3°-4°	G10	8
8000A2633	INGRANAGGIO 2°	2nd GEAR	PIGNON 2°	ZAHNRAD 2. GANG	ENGRANAJE 2°	G10	12
8000A2635	INGRANAGGIO 2°	2nd GEAR	PIGNON 2°	ZAHNRAD 2. GANG	ENGRANAJE 2°	G10	18
8000A2637	INGRANAGGIO 3°	3rd GEAR	PIGNON 3°	ZAHNRAD 3. GANG	ENGRANAJE 3°	G10	24
8000A2638	INGRANAGGIO 4°	4th GEAR	PIGNON 4°	ZAHNRAD 4. GANG	ENGRANAJE 4°	G10	25
8000A2639	INGRANAGGIO 5°	5th GEAR	PIGNON 5°	ZAHNRAD 5. GANG	ENGRANAJE 5°	G10	26
8000A2640	INGRANAGGIO 1°	1st GEAR	PIGNON 1°	ZAHNRAD 1. GANG	ENGRANAJE 1°	G10	29
8000A2643	ALBERO PRIMARIO	MAIN SHAFT	ARBRE PRIMAIRE	HAUPTANTRIEBSWELLE	ARBOL PRIMARIO	G10	1
8000A2644	ALBERO PRIMARIO COMPLETO	MAIN SHAFT ASSEMBLY	ARBRE PRIMAIRE COMPLET	HAUPTANTRIEBSWELLE KOMPLETT	ARBOL PRIMARIO COMPLETO	G10	2
8000A2645	INGRANAGGIO 2°	2nd GEAR	PIGNON 2°	ZAHNRAD 2. GANG	ENGRANAJE 2°	G10	12

INDICE CODICI / DENOMINAZIONI

 CODEX / DESIGNATION INDEX • INDEX CODES / DÉNOMINATIONS
 INHALTSVERZEICHNIS CODE • ÍNDICE CÓDIGOS / DENOMINACIONES

Code	Denominazione	Description	Désignation	Bezeichnung	Descripción	Table	N°
8000A2646	ALBERO SECONDARIO	TRANSMISSION SHAFT	ARBRE SECONDAIRE	VORGELEGEWELLE	ARBOL SECUNDARIO	G10	15
8000A2650	INGRANAGGIO 2°	2nd GEAR	PIGNON 2°	ZAHNRAD 2. GANG	ENGRANAJE 2°	G10	18
8000A2733	TAPPO	PLUG	BOUCHON	VERSCHLUSS	TAPON	A02	36
8000A2734	DECAL	DECAL	ADHESIF	AUFKLEBER	CALCOMANIA	B01	38
8000A2761	ROSETTA	WASHER	RONDELLE	UNTERLEGSCHIEBE	ARANDELA	E02	9
8000A2781	FASCETTA	CLAMP	COLLIER	SCHELLE	CINTA	F07	17
8000A2934	ROSETTA	WASHER	RONDELLE	UNTERLEGSCHIEBE	ARANDELA	G01	54
8000A3099	CD-ROM MANUALE OFFICINA MOTORE	ENGINE OVERHAUL HANDBOOK CD-ROM	CD-ROM MANUEL D'ATELIER MOTEUR	WERKSTATTHANDBUCH MOTOR CD-ROM	CD-ROM MANUAL PARA TALLERES MOTOR	H01	13
8000A3178	GAMBA DX COMPLETA	RH LEG ASSEMBLY	BRAS D. COMPLET	RECHTES BEIN KOMPLETT	PATA HORQUILLA DERECHA COMPLETA	B03	1
8000A3179	GAMBA SX COMPLETA	LH LEG ASSEMBLY	BRAS G. COMPLET	LINKES BEIN KOMPLETT	PATA HORQUILLA IZQUIERDA COMPLETA	B03	2
8000A3226	ANTIVIBRANTE	VIBRATION-DAMPER	ANTI-VIBRATIONS	SCHWINGUNGSDÄMPFER	ANTIVIBRANTE	A02	7
8000A3227	BATTERIA	BATTERY	BATTERIE	BATTERIE	BATERIA	F05	9
8000A3281	ANELLO DI TENUTA	GROMMET	BAGUE D'ETANCHEITE	DICHTUNGSRING	RETEN	G06	37
8000A3406	ATTREZZO MISURA SPORGENZA PISTONI	PISTON PROJECTION MEASURING TOOL	OUTIL MESURE DEPASSEMENT PISTONS	WERKZEUG ZUM MESSEN KOLBENÜBERSTAND	UTIL PARA MEDIR SOBRESALIDA DEL PISTON	J03	7
8000A3445	MOTORE COMPLETO	ENGINE ASSEMBLY	MOTEUR COMPLET	MOTOR KOMPLETT	MOTOR COMPLETO	G01	59
8000A3448	BASAMENTO COMPLETO	ENGINE BLOCK ASSEMBLY	CARTER MOTEUR COMPLET	KURBELGEHÄUSE KOMPLETT	BASE COMPLETA	G01	1
8000A3474	ROSETTA	WASHER	RONDELLE	UNTERLEGSCHIEBE	ARANDELA	A01	36
8000A3486	ROSETTA	WASHER	RONDELLE	UNTERLEGSCHIEBE	ARANDELA	G05	23
8000A3551	PIASTRA PORTAPINZA	CALIPER PLATE	SUPPORT D'ETRIER	BREMSSATTELHALTER	PLACA PORTAPINZA	C01	14
8000A3702	KIT FILTRO OLIO	OIL FILTER KIT	KIT FILTRE A HUILE	UMBAUSATZ ÖLFILTER	KIT FILTRO DE AC EITE	G06	20
8000A3732	SCODELLINO SUPERIORE	UPPER CAP	COUPELLE SUPERIEURE	OBERER FEDERTELLER	TEJUELO SUPERIOR	G04	12
8000A3733	PIATTELLO INFERIORE	LOWER CAP	COUPELLE INFERIEURE	UNTERER FEDERTELLER	ASIENTO INFERIOR	G04	13
8000A3754	CUSCINETTO	BEARING	ROULEMENT	LAGER	COJINETE	G11	3
8000A3812	PARASTRAPPI ALTERNATORE	ALTERNATOR SPRING DRIVE	FLECTEUR ALTERNATEUR	REISSSCHUTZ LICHTMASCHINE	ACOPLAMIENTO FLEXIBLE ALTERNADOR	G14	8
8000A3823	LEVA FRENO ANTERIORE	FRONT BRAKE LEVER	LEVIER DE FREIN AVANT	VORDERRADBREMSEHEBEL	PALANCA FRENO DELANTERO	D03	39
8000A3824	COMPENSATORE DI SCARICO CON CATALIZZATORE	EXHAUST COMPENSATOR WITH CATALYST	COMPENSATEUR D'ECHAPPEMENT AVEC CATALYSEUR	AUSPUFFKOMPENSATOR MIT KATALYSATOR	COMPENSADOR DE ESCAPE CON CATALIZADOR	G16	10
8000A3980	TESTA CILINDRI COMPLETA	CYLINDER HEAD ASSEMBLY	CULASSE COMPLETE	ZYLINDERKOPF KOMPLETT	CULATA COMPLETA	G04	1
8000A3983	INGRANAGGIO (ASPIRAZIONE)	GEAR (INTAKE)	PIGNON (ADMISSION)	ZAHNRAD (EINLASS)	ENGRANAJE (ADMISION)	G05	7
8000A3984	INGRANAGGIO (SCARICO)	GEAR (EXHAUST)	PIGNON (ECHAPPEMENT)	ZAHNRAD (AUSLASS)	ENGRANAJE (ESCAPE)	G05	8
8000A3985	ALBERO MOTORE COMPLETO	DRIVING SHAFT ASSEMBLY	VILEBREQUIN COMPLET	KURBELWELLE KOMPLETT	CIGÜEÑAL COMPLETO	G02	1
8000A3996	TUBO OLIO FRENO ANTERIORE	FRONT BRAKE OIL PIPE	CANALISATION DE LIQUIDE FREIN AVANT	BREMSLEITUNG VORDERRADBREMSE	TUBO ACEITE FRENO DELANTERO	D03	17
8000A3997	AMMORTIZZATORE POST.	REAR SHOCK ABSORBER	AMORTISSEUR ARRIERE	HINTERER STOSSDÄMPFER	AMORTIGUADOR TRASERO	B02	17
8000A4000	TARGHETTA PNEUMATICI	TYRES DATA PLATE	PLAQUETTE PNEUMATIQUES	SCHILD REIFEN	ETIQUETA NEUMATICOS	A01	34
8000A4020	LIBRETTO USO E MANUTENZIONE (I)	USE AND MAINTENANCE HANDBOOK (I)	LIVRET UTILISATION ET ENTRETIEN (I)	BEDIENUNGSANLEITUNG (I)	MANUAL DE MANTENIMIENTO (I)	H01	6
8000A4021	OWNER'S MANUAL (USA)	OWNER'S MANUAL (USA)	OWNER'S MANUAL (USA)	OWNER'S MANUAL (USA)	OWNER'S MANUAL (USA)	H01	6
8000A4196	ROSETTA	WASHER	RONDELLE	UNTERLEGSCHIEBE	ARANDELA	G10	19
						G10	22
8000A4317	ATTREZZO PER FILTRO OLIO	OIL FILTER TOOL	OUTIL POUR FILTRE A HUILE	WERKZEUG FÜR ÖLFILTER	UTIL PARA FILTRO ACEITE	J04	6
8000A4508	REGISTRO	REGISTER	ECROU DE REGLAGE	EINSTELLVORRICHTUNG	REGULADOR	B02	3
8000A4539	TAPPO	PLUG	BOUCHON	VERSCHLUSS	TAPON	B01	41
8000A4580	TARGHETTA REGOLAZIONE CATENA	CHAIN ADJUSTMENT PLATE	PLAQUETTE REGLAGE CHAINE	SCHILD KETTENEINSTELLUNG	ETIQUETA REGULACION CADENA	B01	28
8000A4581	COPRICATENA INFERIORE	LOWER CHAIN COVER	CARTER DE CHAINE INFERIEUR	UNTERER KETTENSCHUTZ	CUBRECADENA INFERIOR	B01	27
8000A4686	ATTREZZATURA CONTROLLO CO	CO CONTROL TOOL ASSEMBLY	OUTIL CONTROLE DU CO	CO-KONTROLLEHALTERUNG	UTIL CONTROL CO	J04	7
8000A4690	PARAPOLVERE	DUST COVER	JOINT-POUSSERIE	STAUBSCHUTZRING	GUARDAPOLVO	B04	9
						B05	9

INDICE CODICI / DENOMINAZIONI

CODEX / DESIGNATION INDEX • INDEX CODES / DÉNOMINATIONS

INHALTSVERZEICHNIS CODE • ÍNDICE CÓDIGOS / DENOMINACIONES

Code	Denominazione	Description	Désignation	Bezeichnung	Descripción	Table	N°
8000A4691	ASSIEME PACCO COMPRESSIONE	COMPRESSION PACK ASSEMBLY	ENSEMBLE PAQUET COMPRESSION	BAUGRUPPE KOMPRESSIONSPAKET	CONJUNTO PAQUETE COMPRESION	B04	18
						B05	18
8000A4692	CARTUCCIA	CARTRIDGE	CARTOUCHE	PATRONE	CARTUCHO	B04	15
						B05	15
8000A4693	TAPPO COMPLETO	PLUG ASSEMBLY	BOUCHON COMPLET	VERSCHLUSS KOMPLETT	TAPON COMPLETO	B04	28
						B05	28
8000A4780	ROSETTA	WASHER	RONDELLE	UNTERLEGSCHEIBE	ARANDELA	G10	40
8000A4827	CORPO FARFALLATO	THROTTLE BODY	CORPS DE PAPILLON	DROSSELKÖRPER	CUERPO CON VALVULA DE MARIPOSA	G13	9
8000A4891	SILENZIATORE SUPERIORE	UPPER SILENCER	SILENCIEUX SUPERIEUR	OBERER SCHALLDÄMPFER	SILENCIADOR SUPERIOR	G16	12
8000A4892	SILENZIATORE INFERIORE	LOWER SILENCER	SILENCIEUX INFERIEUR	UNTERER SCHALLDÄMPFER	SILENCIADOR INFERIOR	G16	16
8000A5018	KIT GUARNIZIONE TESTA	HEAD GASKET KIT	KIT DES JOINTS DE CULASSE	ZYLINDERKOPFDICHTUNG- BAUSATZ	KIT DE JUNTAS CULATA	J04	13
8000A5019	KIT GUARNIZIONE TESTA	HEAD GASKET KIT	KIT DES JOINTS DE CULASSE	ZYLINDERKOPFDICHTUNG- BAUSATZ	KIT DE JUNTAS CULATA	J04	14
8000A5183	PROTEZIONE SERBATOIO	FUEL TANK PROTECTION	PROTECTION DERESERVOIR	BENZINTANK ABDECKUNG	PROTECCION PARA DEPOSITO	E04	14
8000A5184	SERBATOIO BENZINA	FUEL TANK	RESERVOIR D'ESSENCE	BENZINTANK	DEPOSITO GASOLINA	E04	6
8000A5235	VITE FISSAGGIO BIELLA	CONNECTING ROD CLAMP SCREW	VIS DE FIXATION	BIELLE PLEUEL BEFESTIGUNGSSCHRAUBE	TORNILLO FIJACION BIELLA	G02	4
8000A5236	BIELLA COMPLETA	CONNECTING ROD ASSEMBLY	BIELLE COMPLETE	PLEUEL KOMPLETT	BIELLA COMPLETA	G02	3
8000A5237	VITE FISSAGGIO BIELLA	CONNECTING ROD CLAMP SCREW	VIS DE FIXATION	BIELLE PLEUEL BEFESTIGUNGSSCHRAUBE	TORNILLO FIJACION BIELLA	G02	4
8000A5238	BIELLA COMPLETA	CONNECTING ROD ASSEMBLY	BIELLE COMPLETE	PLEUEL KOMPLETT	BIELLA COMPLETA	G02	3
8000A5239	DECAL	DECAL	ADHESIF	AUFKLEBER	CALCOMANIA	E01	25
8000A5241	PARAFANGO ANTERIORE	FRONT MUDGUARD	GARDE-BOUE AVANT	VORDERER KOTFLÜGEL	GUARDABARRAS DELANTERO	E01	1
8000A5350	TELERUTTORE AVVIAMENTO	SOLENOID STARTER	TELERUPTEUR DU DEMARREUR	ANLASSER FERNRELAIS	TELERRUPTOR DE ARRANQUE	F05	3
8000A5353	AGGIORNAMENTO SOFTWARE DIAGNOSTICA	DIAGNOSTIC SOFTWARE UPDATE	MISE A JOUR LOGICIEL DIAGNOSTIC	AKTUALISIERUNG DIAGNOSE-SOFTWARE	ACTUALIZACION SOFTWARE DIAGNOSTICA	J03	24
8000A5393	CAVO INTERFACCIA	INTERFACE CABLE	CABLE D'INTERFACE	INTERFACE KABEL	CABLE DE INTERFAZ	J03	25
8000A5394	SOFTWARE DIAGNOSTICA	DIAGNOSTIC SOFTWARE	LOGICIEL DIAGNOSTIC	DIAGNOSE-SOFTWARE	SOFTWARE DIAGNOSTICA	J03	6
8000A6106	COPRICATENA SUPERIORE	UPPER CHAIN COVER	CARTER DE CHAINE SUPERIEUR	OBERER KETTENSCHUTZ	CUBRECADENA SUPERIOR	B01	24
8000A6180	CD-ROM MANUALE OFFICINA MOTOTELAIO	CHASSIS OVERHAUL HANDBOOK CD-ROM	CD-ROM MANUEL MECANIQUE GENERALE	WERKSTATTHANDBUCH MOTORRADRAHMEN CD-ROM	CD-ROM MANUAL PARA TALLERES VEHICULO	H01	12
8000A9300	CENTRALINA SERVIZI	SERVICE POWER UNIT	BOITIER DE SERVICES	DIENST-STEUERUNG	CENTRALITA DE SERVICIO	F07	11
8000A9317	SUPPORTO	SUPPORT	SUPPORT	HALTERUNG	SOPORTE	E05	25
8000A9615	CENTRALINA SERVIZI	SERVICE POWER UNIT	BOITIER DE SERVICES	DIENST-STEUERUNG	CENTRALITA DE SERVICIO	F07	11
8000A9616	COPERCHIO CENTRALINA	SERVICE POWER UNIT COVER	COUVERCLE DU BOITIER	STEUERUNGDECKEL	TAPA CENTRALITA	F07	12
8000B2143	MOZZO ECCENTRICO	ECCENTRIC HUB	MOYEU DECENTRE	EXZENTERNABE	CUBO EXCENTRICO	C01	4
8000B2149	DISTANZIALE	PACER	ENTRETOISE	ABSTANDHALTER	DISTANCIADOR	C01	6
8000B2859	TUBO	PIPE	TUYAU	LEITUNG	TUBO	J03	26
8000B3392	PERNO RUOTA POSTERIORE	REAR WHEEL PIN	AXE ROUE ARRIERE	HINTERRADACHSE	PERNO RUEDA TRASERA	C01	7
8000B3584	PIASTRINA AGGANCIO MOLLA SPRING FIXING BRACKET	INNER SPRING	PLAQUETTE D'ACCROCHEMENT DU RESSORT	FEDERANLENKUNG INNENFEDER	MUELLE INT.	A01	22
8000B3986	MOLLA INTERNA	INNER SPRING	RESSORT INT.	INNENFEDER	MUELLE INT.	A01	39
8000B3987	MOLLA ESTERNA	OUTER SPRING	RESSORT EXT.	AUSSENFEDER	MUELLE EXT.	A01	38
8000B4782	PIASTRA	PLATE	PLAQUE	PLATTE	PLACA	A01	15
8000B4954	KIT MOZZO- PERNO- DISTANZIALE	HUB-PIN-SPACER KIT	KIT MOYEU-AXE- ENTRETOISE	BAUSATZ NABE-ACHSE- ABSTANDHALTER	KIT CUBO-PERNO- DISTANCIADOR	C01	37
8000B4955	DISTANZIALE	SPACER	ENTRETOISE	ABSTANDHALTER	DISTANCIADOR	C01	31
80A047053	VITE M4X8	SCREW M4X8	VIS M4X8	SCHRAUBE M4X8	TORNILLO M4X8	A02	19
80A053546	PERNO PEDANA	FOOTBOARD PIN	AXE DE CALE-PIED	FUSSRASTENBOLZEN	PERNO ESTRIBO	A02	22
80A053548	PERNO LEVA FRENO POSTERIORE	REAR BRAKE LEVER PIN	AXE LEVIER FREIN ARRIERE	BOLZEN BREMSPEDALHEBEL HINTERRADBREMSE	PERNO PALANCA FRENO TRASERO	D02	27
80A055757	FORCELLA POMPA FRENO POSTERIORE	REAR BRAKE PUMP FORK	FOURCHETTE MAITRE-CYL. FREIN ARRIERE	GABEL BREMSPUMPE HINTERRADBREMSE	HORQUILLA BOMBA FRENO TRASERO	D02	25

INDICE CODICI / DENOMINAZIONI

 CODEX / DESIGNATION INDEX • INDEX CODES / DÉNOMINATIONS
 INHALTSVERZEICHNIS CODE • ÍNDICE CÓDIGOS / DENOMINACIONES

Code	Denominazione	Description	Désignation	Bezeichnung	Descripción	Table	N°
80A063228	VITE AUTOFILETTANTE 2,5X9,5	TAPPING SCREW 2,5X9,5	VIS TARAUD 2,5X9,5	BLECHSCHRAUBE 2,5X9,5	TORNILLO AUTORROSCANTE 2,5X9,5	A02	35
80A081478	CILINDRO COMANDO FRIZIONE	CLUTCH CONTROL CYLINDER	CYLINDRE RECEPTEUR DEBRAYAGE	KUPPLUNGZYLINDER	CILINDRO ACCIONAMIENTO EMBRAGUE	G09	13
80A084901	SPINA	PIN	GOUJON	STIFT	PERNO	C01	8
80A086728	COPERCHIO	COVER	COUVERCLE	DECKEL	TAPA	G01	45
80A087761	COPERCHIO TERMOSTATO	THERMOSTAT COVER	COUVERCLE DU THERMOSTAT	THERMOSTATDECKEL	TAPA TERMOSTATO	G08	67
80A089405	RACCORDO ENTRATA POMPA ACQUA	WATER PUMP INLET UNION	RACCORD D'ENTREE POMPE A EAU	ANSCHLUSS EINLASS WASSERPUMPE	RACOR ENTRADA BOMBA AGUA	G07	18
80A089412	COPERCHIO POMPA ACQUA	WATER PUMP COVER	COUVERCLE DE POMPE A EAU	WASSERPUMPENDECKEL	TAPA BOMBA AGUA	G07	12
80A090431	PERNO	PIN	AXE	ZAPFEN	PERNO	A01	17
80A090432	DADO M8	NUT M8	ECROU M8	MUTTER M8	TUERCA M8	A01	18
80A090925	TERMINALE DI INNESTO	COUPLER	RACCORD	VERBINDUNGSTEIL	TERMINAL DE CONEXION	G12	4
80A091661	PEDANA SX	LH FOOTBOARD	CALE-PIED G.	LINKE FUSSRASTE	ESTRIBO IZQUIERDO	A02	24
80A091662	PEDANA DX	RH FOOTBOARD	CALE-PIED D.	RECHTE FUSSRASTE	ESTRIBO DERECHO	A02	29
80A091923	COLLETTORE ENTRATA ACQUA	WATER INLET MANIFOLD	COLLECTEUR ENTREE D'EAU	WASSERFÄNGER	COLECTOR ENTRADA AGUA	G08	74
80A092469	COPPA OLIO	OIL PAN	CARTER D'HUILE	ÖLWANNE	CARTER ACEITE	G01	47
80A092494	COPERCHIO CATENA	CHAIN COVER	COUVERCLE DE CHAINE	KETTENSCHUTZ	TAPA CADENA	G11	41
80A092671	COPRICATENA SUPERIORE	UPPER CHAIN COVER	CARTER DE CHAINE SUPERIEUR	OBERER KETTENSCHUTZ	CUBRECADENA SUPERIOR	B01	24
80A093317	COPRICATENA INFERIORE	LOWER CHAIN COVER	CARTER DE CHAINE INFERIEUR	UNTERER KETTENSCHUTZ	CUBRECADENA INFERIOR	B01	27
80A094169	SUPPORTO PEDANA POSTERIORE SX	LH REAR FOOTBOARD SUPPORT	SUPPORT DE CALE-PIED ARRIERE G.	HALTERUNG HINTERE LINKE FUSSRASTE	SOPORTE ESTRIBO TRASERO IZQUIERDO	A02	21
80A094632	CERCHIO RUOTA ANTERIORE	FRONT RIM	JANTE ROUE AVANT	VORDERRADFELGE	LLANTA RUEDA DELANTERA	C02	1
80A097904	TELAIO	CHASSIS	CADRE	RAHMEN	BASTIDOR	A01	1
80A098020	GRUPPO CILINDRI	CYLINDERS ASSEMBLY	GROUPE CYLINDRES	ZYLINDEREINHEIT	CONJUNTO CILINDROS	G03	1
80A098313	FIANCHETTO SX SERBATOIO	FUEL TANK LH SIDE	CACHE G. RESERVOIR	LINKE TANK- SEITENVERKLEIDUNG	LATERAL IZQUIERDO DEPOSITO	E04	5
80A098314	FIANCHETTO DX SERBATOIO	FUEL TANK RH SIDE	CACHE D. RESERVOIR	RECHTE TANK- SEITENVERKLEIDUNG	LATERAL DERECHO DEPOSITO	E04	3
80A098338	RETROVISORE DX	RH REARVIEW MIRROR	RETROVISEUR D.	RECHTER RÜCKSPIEGEL	RETROVISOR DERECHO	E02	1
80A098339	RETROVISORE SX	LH REARVIEW MIRROR	RETROVISEUR G.	LINKER RÜCKSPIEGEL	RETROVISOR IZQUIERDO	E02	2
80A098699	SUPPORTO SX RADIATORE OLIO	LH OIL COOLER SUPPORT	SUPPORT DE RADIATEUR D'HUILE G.	LINKE ÖLKÜHLER- HALTERUNG	SOPORTE IZQUIERDO RADIADOR ACEITE	G08	26
80A098700	SUPPORTO DX RADIATORE OLIO	RH OIL COOLER SUPPORT	SUPPORT DE RADIATEUR D'HUILE D.	RECHTE ÖLKÜHLER- HALTERUNG	SOPORTE DERECHO RADIADOR ACEITE	G08	26
80A098721	SUPPORTO PEDANA POSTERIORE DX	RH REAR FOOTBOARD SUPPORT	SUPPORT DE CALE-PIED ARRIERE D.	HALTERUNG HINTERE RECHTE FUSSRASTE	SOPORTE ESTRIBO TRASERO DERECHO	A02	28
80A098830	DECAL	DECAL	ADHESIF	AUFKLEBER	CALCOMANIA	E05	7
80A098831	DECAL	DECAL	ADHESIF	AUFKLEBER	CALCOMANIA	E05	15
80A098832	DECAL	DECAL	ADHESIF	AUFKLEBER	CALCOMANIA	E04	7
80A098835	SUPPORTO FILTRO OLIO	OIL FILTER SUPPORT	SUPPORT FILTRE A HUILE	ÖLFILTERHALTERUNG	SOPORTE FILTRO DEL ACEITE	G06	22
80A098837	FLANGIA SUPPORTO TUBI OLIO	OIL PIPES SUPPORT FLANGE	FLASQUE DE SUPPORT DES CANALISATIONS D'HUILE	ÖLLEITUNGSHALTERUNG- FLANSCH	BRIDA DE SOPORTE TUBOS DEL ACEITE	G01	31
80A098856	FIANCHETTO DX SERBATOIO	FUEL TANK RH SIDE	CACHE D. RESERVOIR	RECHTE TANK- SEITENVERKLEIDUNG	LATERAL DERECHO DEPOSITO	E04	3
80A098857	FIANCHETTO SX SERBATOIO	FUEL TANK LH SIDE	CACHE G. RESERVOIR	LINKE TANK- SEITENVERKLEIDUNG	LATERAL IZQUIERDO DEPOSITO	E04	5
80A098862	CHIUSURA POSTERIORE DX CILINDRI	CYLINDERS REAR RH COVER	COUVERCLE ARRIERE D. DE CYLINDRES	HINTERE RECHTE ZYLINDERDECKEL	TAPA TRASERA DERECHA CILINDROS	E02	17
80A098863	CHIUSURA POSTERIORE SX CILINDRI	CYLINDERS REAR LH COVER	COUVERCLE ARRIERE G. DE CYLINDRES	HINTERE LINKE ZYLINDERDECKEL	TAPA TRASERA IZQUIERDA CILINDROS	E01	18
80A099116	SELLA PILOTA	DRIVER'S SADDLE	SELLE PILOTE	FAHRERSITZ	SILLIN PILOTO	E05	19
80A099118	SELLA PASSEGGERO	PILLION	SELLE PASSAGER	BEIFAHRSERSITZ	SILLIN PASAJERO	E05	24

INDICE CODICI / DENOMINAZIONI

CODEX / DESIGNATION INDEX • INDEX CODES / DÉNOMINATIONS

INHALTSVERZEICHNIS CODE • ÍNDICE CÓDIGOS / DENOMINACIONES

Code	Denominazione	Description	Désignation	Bezeichnung	Descripción	Table	N°
80A099139	STAFFA SILENZIATORI	SILENCERS CLAMP	BRIDE SILENCIEUX D'ÉCHAPPEMENT	BEFESTIGUNG SCHÄLLDAMPFER	BRIDA SILENCIADOR DE ESCAPE	G16	24
80A099286	FIANCHETTO DX CODINO	TAIL RH SIDE FAIRING	CACHE D. COQUE ARRIERE	RECHTE HECKTEIL- VERKLEIDUNG	LATERAL DERECHO COLA	E05	14
80A099287	FIANCHETTO SX CODINO	TAIL LH SIDE FAIRING	CACHE G. COQUE ARRIERE	LINKE HECKTEIL- VERKLEIDUNG	LATERAL IZQUIERDO COLA	E05	5
80A099325	SERBATOIO BENZINA	FUEL TANK	RESERVOIR D'ESSENCE	BENZINTANK	DEPOSITO GASOLINA	E04	6
80A099431	CODINO	TAIL	COQUE ARRIERE	HECKTEIL	COLA	E05	1
80A099433	COPERTURA CRUSCOTTO	DASHBOARD COVER	COUVRE-COMBINE DE BORD	ARAMTURENBRETTDECKEL	TAPA TABLERO	E01	11
80A0A1500	GAMBA DX COMPLETA	RH LEG ASSEMBLY	BRAS D. COMPLET	RECHTES BEIN KOMPLETT	PATA HORQUILLA DERECHA COMPLETA	B03	1
80A0A1501	GAMBA SX COMPLETA	LH LEG ASSEMBLY	BRAS G. COMPLET	LINKES BEIN KOMPLETT	PATA HORQUILLA IZQUIERDA COMPLETA	B03	2
80A0A1558	TUBO MANDATA BENZINA	FUEL DELIVERY PIPE	CANALISATION REFOULEMENT ESSENCE	BENZIN-ZULEITUNG	TUBO ENVIO GASOLINA	G13	7
80A0A1857	STELO SX COMPLETO	LH STEM ASSEMBLY	TUBE G. COMPLET	LINKER SCHAFT KOMPLETT	VASTAGO IZQ. COMPLETO	B05	4
80A0A1858	STELO DX COMPLETO	RH STEM ASSEMBLY	TUBE D. COMPLET	RECHTER SCHAFT KOMPLETT	VASTAGO DER. COMPLETO	B04	4
80A0A1875	TUBO MANDATA BENZINA	FUEL DELIVERY PIPE	CANALISATION REFOULEMENT ESSENCE	BENZIN-ZULEITUNG	TUBO ENVIO GASOLINA	J04	4
80A0A5183	PROTEZIONE SERBATOIO	FUEL TANK PROTECTION	PROTECTION DERESERVOIR	BENZINTANK ABDECKUNG	PROTECCION PARA DEPOSITO	E04	14
80A0A5184	SERBATOIO BENZINA	FUEL TANK	RESERVOIR D'ESSENCE	BENZINTANK	DEPOSITO GASOLINA	E04	6
80A0A6107	COPRICATENA SUPERIORE	UPPER CHAIN COVER	CARTER DE CHAINE SUPERIEUR	OBERER KETTENSCHUTZ	CUBRECADENA SUPERIOR	B01	24
80A0B3583	CAVALLETTO LATERALE	SIDE STAND	BEQUILLE LATERALE	SEITENSTÄNDER	CABALLETE LATERAL	A01	16
80A0B4781	KIT CAVALLETTO LATERALE	SIDE STAND KIT	KIT BEQUILLE LATERALE	BAUSATZ STÄNDER	KIT CABALLETE LATERAL	A01	40
80B043928	DADO M8	NUT M8	ECROU M8	MUTTER M8	TUERCA M8	A02	4
						G16	27
80B073832	CATADIOTTRO	RETROREFLECTOR	REFLECTEUR	KATZENAUGE	CATAFARO	K01	11
80B090316	DECAL	DECAL	ADHESIF	AUFKLEBER	CALCOMANIA	E01	10
						E05	2
80B090321	DECAL	DECAL	ADHESIF	AUFKLEBER	CALCOMANIA	E04	29
80B097904	TELAIO	CHASSIS	CADRE	RAHMEN	BASTIDOR	A01	1
80B098831	DECAL	DECAL	ADHESIF	AUFKLEBER	CALCOMANIA	E05	6
						E05	15
80B098832	DECAL	DECAL	ADHESIF	AUFKLEBER	CALCOMANIA	E04	7
80B099116	SELLA PILOTA	DRIVER'S SADDLE	SELLE PILOTE	FAHRERSITZ	SILLIN PILOTO	E05	19
80B099118	SELLA PASSEGGERO	PILLION	SELLE PASSAGER	BEIFAHRSITZ	SILLIN PASAJERO	E05	24
80B099286	FIANCHETTO DX CODINO	TAIL RH SIDE FAIRING	CACHE D. COQUE ARRIERE	RECHTE HECKTEIL- VERKLEIDUNG	LATERAL DERECHO COLA	E05	14
80B099287	FIANCHETTO SX CODINO	TAIL LH SIDE FAIRING	CACHE G. COQUE ARRIERE	LINKE HECKTEIL- VERKLEIDUNG	LATERAL IZQUIERDO COLA	E05	5
80C098832	DECAL	DECAL	ADHESIF	AUFKLEBER	CALCOMANIA	E04	7
80D090321	DECAL	DECAL	ADHESIF	AUFKLEBER	CALCOMANIA	E04	29
80E0A5240	PARAFANGO ANTERIORE	FRONT MUDGUARD	GARDE-BOUE AVANT	VORDERER KOTFLÜGEL	GUARDABARRO DELANTERO	E01	1
80G0A5240	PARAFANGO ANTERIORE	FRONT MUDGUARD	GARDE-BOUE AVANT	VORDERER KOTFLÜGEL	GUARDABARRO DELANTERO	E01	1
80H0A5240	PARAFANGO ANTERIORE	FRONT MUDGUARD	GARDE-BOUE AVANT	VORDERER KOTFLÜGEL	GUARDABARRO DELANTERO	E01	1
8A0018246	LAMPADA	BULB	AMPOULE	LAMPE	LAMPARA	F06	3
8A0021774	CUSCINETTO	BEARING	ROULEMENT	LAGER	COJINETE	G11	13
8A0023120	ANELLO DI TENUTA	GROMMET	BAGUE D'ÉTANCHEITE	DICHTUNGSRING	RETEN	G01	44
8A0025044	CUSCINETTO	BEARING	ROULEMENT	LAGER	COJINETE	G10	10
8A0025082	ANELLO DI TENUTA	GROMMET	BAGUE D'ÉTANCHEITE	DICHTUNGSRING	RETEN	G04	20
8A0028855	ANELLO DI TENUTA	GROMMET	BAGUE D'ÉTANCHEITE	DICHTUNGSRING	RETEN	G07	3
						G11	37
8A0031106	ANELLO DI TENUTA	GROMMET	BAGUE D'ÉTANCHEITE	DICHTUNGSRING	RETEN	G01	34
8A0036022	ROSETTA	WASHER	RONDELLE	UNTERLEGSCHIBE	ARANDELA	G11	12

INDICE CODICI / DENOMINAZIONI

 CODEX / DESIGNATION INDEX • INDEX CODES / DÉNOMINATIONS
 INHALTSVERZEICHNIS CODE • ÍNDICE CÓDIGOS / DENOMINACIONES

Code	Denominazione	Description	Désignation	Bezeichnung	Descripción	Table	N°
8A0051549	BOCCOLA	BUSH	PION	BUCHSE	CASQUILLO	G01	13
8A0061070	VITE M6X8	SCREW M6X8	VIS M6X8	SCHRAUBE M6X8	TORNILLO M6X8	G16	14
						G16	18
8A0066531	VITE M5X25	SCREW M5X25	VIS M5X25	SCHRAUBE M5X25	TORNILLO M5X25	D05	6
8A0066778	VITE AUTOFILETTANTE 3,9X13	TAPPING SCREW 3,9X13	VIS TARAUD 3,9X13	BLECHSCHRAUBE 3,9X13	TORNILLO AUTORROSCANTE 3,9X13	G08	45
8A0067545	VITE M6X35	SCREW M6X35	VIS M6X35	SCHRAUBE M6X35	TORNILLO M6X35	D02	33
						G01	5
						G07	20
8A0067997	VITE M5X16	SCREW M5X16	VIS M5X16	SCHRAUBE M5X16	TORNILLO M5X16	E05	23
						K02	8
8A0081228	GUIDA VALVOLA	VALVE GUIDE	GUIDE DE SOUPAPE	VENTILFÜHRUNG	GUIA VALVULA	G04	3
8A0081315	SEMICUSCINETTO DI BIELLA (BLU)	BIG END HALF BEARING (BLUE)	DEMI-COUSSINET DI BIELLE (BLEU)	PLEUELLAGERHÄLFTE (BLAU)	SEMICOJINETE DE BIELA (AZUL)	G02	5
8A0081316	SEMICUSCINETTO DI BANCO (BLU)	CRANKSHAFT HALF BEARING (BLUE)	DEMI-COUSSINET DE PALIER (BLU)	KURBELWELLEN- LAGERHÄLFTE (BLAU)	SEMICOJINETE PRINCIPAL (AZUL)	G01	17
8A0081317	SEMICUSCINETTO DI BANCO (BLU)	CRANKSHAFT HALF BEARING (BLUE)	DEMI-COUSSINET DE PALIER (BLU)	KURBELWELLEN- LAGERHÄLFTE (BLAU)	SEMICOJINETE PRINCIPAL (AZUL)	G01	16
8A0081387	ALTERNATORE	ALTERNATOR	ALTERNATEUR	LICHTMASCHINE	ALTERNADOR	G15	1
8A0081466	DISTANZIALE	SPACER	ENTRETOISE	ABSTANDHALTER	DISTANCIADOR	G10	32
8A0081517	ROSETTA	WASHER	RONDELLE	UNTERLEGSCHEIBE	ARANDELA	G09	18
8A0081584	FORCELLA INNESTO MARCE	SHIFTING FORK	FOURCHETTE DE SELECTION	SCHALTGABEL	HORQUILLA ENGRANE MARCHA	G11	17
8A0082759	DISCO FRENO ANTERIORE	FRONT BRAKE DISK	DISQUE FREIN AV.	BREMSSCHEIBE VORDERRADBREMSE	DISCO FRENO DELANTERO	C02	5
8A0084182	PASTIGLIA REGOLAZIONE GIOCO (SP.1.65)	CLEARANCE ADJUSTING PAD (THICKNESS 1.65)	PASTILLE DE CALAGE (EP.1.65)	EINSTELLPLÄTTCHEN VENTILSPIEL (STÄRKE 1.65)	PASTILLA REGULACION JUEGO (SP.1.65)	G05	21
8A0084857	BUSSOLA FISSAGGIO MOTORE	ENGINE FIXING BUSH	BAGUE ANCRAGE MOTEUR	MOTOR- BEFESTIGUNGSBUCHSE	BUJE FIJACION MOTOR	A01	10
8A0086407	LIMITATORE STERZATA	STEERING LIMITING DEVICE	LIMITEUR ANGLE DE BRAQUAGE	LENKBEGRENZER	LIMITADOR DE VIRAJE	B03	5
8A0087313	DISTANZIALE	SPACER	ENTRETOISE	ABSTANDHALTER	DISTANCIADOR	G09	19
8A0089299	BUSSOLA	BUSH	BAGUE	HÜLSE	CASQUILLO	G16	22
8A0089416	ALBERO COMANDO FORCELLE	FORK CONTROL SHAFT	BARILLET DE SELECTION	STEUERWELLE SCHALTGABELN	EJE ACCIONAMIENTO HORQUILLA	G11	11
8A0089628	TARGHETTA CENTRALINA	POWER UNIT DATA PLATE	PLAQUETTE DE BOITIER DE CONTROLE	SCHILD FÜR STEUERUNG	ETIQUETA PARA CENTRALITA	F07	3
8A0089786	VITE M6X12	SCREW M6X12	VIS M6X12	SCHRAUBE M6X12	TORNILLO M6X12	A01	24
						B01	26
						E04	28
						F01	10
						G08	21
8A0090280	GHIERA	RING NUT	ECROU	GEWINDERING	VIROLA	B03	11
8A0090372	INDICATORE DI DIREZIONE POSTERIORE DX	RH REAR TURN INDICATOR	FEU CLIGNOTANT ARRIERE D.	HINTERER RECHTER BLINKER	INDICADOR DE DIRECCION TRASERO DERECHO	F01	14
8A0090373	INDICATORE DI DIREZIONE POSTERIORE SX	LH REAR TURN INDICATOR	FEU CLIGNOTANT ARRIERE G.	HINTERER LINKER BLINKER	INDICADOR DE DIRECCION TRASERO IZQUIERDO	F01	21
8A0090424	VITE M5X8	SCREW M5X8	VIS M5X8	SCHRAUBE M5X8	TORNILLO M5X8	E03	5
8A0090901	VITE M4X13,7	SCREW M4X13,7	VIS M4X13,7	SCHRAUBE M4X13,7	TORNILLO M4X13,7	B01	30
						E01	9
						E01	16
						E01	19
						E02	15
						E02	19
						G08	14
						G08	18
8A0090940	TUBO IN GOMMA	HOSE	DURIT	GUMMISCHLAUCH	TUBO DE GOMA	K02	14
8A0090944	TAPPO	PLUG	BOUCHON	VERSCHLUSS	TAPON	G08	48

INDICE CODICI / DENOMINAZIONI

CODEX / DESIGNATION INDEX • INDEX CODES / DÉNOMINATIONS

INHALTSVERZEICHNIS CODE • ÍNDICE CÓDIGOS / DENOMINACIONES

Code	Denominazione	Description	Désignation	Bezeichnung	Descripción	Table	N°
8A0091634	FASCETTA A MOLLA	SPRING CLAMP	COLLIER A RESSORT	FEDERSCHELLE	CINTA ELASTICA	G13 K02	6 18
8A0091693	GUARNIZIONE	GASKET	JOINT	DICHTUNG	EMPAQUE	A01	30
8A0091697	VITE M8X60	SCREW M8X60	VIS M8X60	SCHRAUBE M8X60	TORNILLO M8X60	G01 G01	8 56
8A0092256	FASCETTA CLIC R	CLIC R CLAMP	COLLIER CLIC R	SHELLE CLIC R	ABRAZADERA CLIC R	K02	16
8A0094186	TUBO CARICAMENTO RADIATORE	RADIATOR FILLING PIPE	CANALISATION DE REPLISSAGE RADIATEUR	ZULEITUNG KÜHLER	TUBO CARGA RADIADOR	G08	60
8A0094275	FLANGIA INFERIORE SERBATOIO	FUEL TANK LOWER FLANGE	PLATEAU INFERIEUR DU RESERVOIR	UNTERE TANKFLANSCH	SOPORTE INFERIOR DEPOSITO	G12	1
8A0094792	ATTREZZO MONTAGGIO CAMBIO	CHANGE GEAR ASSEMBLY TOOL	OUTIL MONTAGE BOITE DE VITESSES	WERKZEUG GETRIEBEMONTAGE	UTIL MONTAJE CAMBIO	J03	1
8A0096565	ROSETTA	WASHER	RONDELLE	UNTERLEGSCHIBE	ARANDELA	G10	38
8A0097089	TUBO IN GOMMA	HOSE	DURIT	GUMMISCHLAUCH	TUBO DE GOMA	K02	13
8A0097109	TUBO RADIATORE/POMPA	COOLER/PUMP PIPE	CANALISATION RADIATEUR/ POMPE	LEITUNG KÜHLER/PUMPE	TUBO RADIADOR/BOMBA	G08	57
8A0097739	TAMBURO SELETTOR MARCE	GEARS SELECTING DRUM	TAMBOUR DE SELECTION	GANGWAHLTROMMEL	TAMBOR SELECTOR MARCHA	G11	20
8A0098679	GUARNIZIONE TESTA (SP. 1.3)	HEAD GASKET (THICKNESS 1.3)	JOINT DE CULASSE (EP. 1.3)	ZYLINDERKOPFDICHTUNG (STÄRKE 1.3)	JUNTA CULATA (SP. 1.3)	G03	8
8A0098714	TUBO IN GOMMA	HOSE	DURIT	GUMMISCHLAUCH	TUBO DE GOMA	K02	12
8A0098841	VITE DI FASATURA	TIMING SCREW	VIS DE CALAGE	SCHRAUBE PHASENAUSRICHTUNG	TORNILLO PARA FASE	G06	19
8A0099270	CENTRALINA INIEZIONE (F)	INJECTION POWER UNIT (F)	BOITIER DE CONTROLE INIECTION (F)	EINSPRITZ-STEUERUNG (F)	CENTRALITA INJECCION (F)	F07	1
8A0099272	EPROM (F)	EPROM (F)	EPROM (F)	EPROM (F)	EPROM (F)	F07	2
8A0099358	LIBRETTO USO E MANUTENZIONE (GB)	USE AND MAINTENANCE HANDBOOK (GB)	LIVRET UTILISATION ET ENTRETIEN (GB)	BEDIENUNGSANLEITUNG (GB)	MANUAL DE MANTENIMIENTO (GB)	H01	6
8A0099360	MANUALE OFFICINA MOTOTELAIO (GB)	ENGINE OVERHAUL HANDBOOK (GB)	MANUEL D'ATELIER MECANIQUE GEN. (GB)	WERKSTATTHANDBUCH MOTORRADRAHMEN (GB)	MANUAL PARA TALLERES VEHICULO (GB)	H01	10
8A00A1234	ROSETTA	WASHER	RONDELLE	UNTERLEGSCHIBE	ARANDELA	G10	38
8A00A1592	MANUALE OFFICINA MOTORE (GB)	ENGINE OVERHAUL HANDBOOK (GB)	MANUEL D'ATELIER MOTEUR (GB)	WERKSTATTHANDBUCH MOTOR (GB)	MANUAL PARA TALLERES MOTOR (GB)	H01	11
8A00A2306	GUIDA VALVOLA COMPLETO	VALVE GUIDE ASSEMBLY	GUIDE DE SOUPAPE COMPLETE	VENTILFÜHRUNG KOMPLETT	GUIA VALVULA COMPLETA	G04	25
8A00A4020	LIBRETTO USO E MANUTENZIONE (GB)	USE AND MAINTENANCE HANDBOOK (GB)	LIVRET UTILISATION ET ENTRETIEN (GB)	BEDIENUNGSANLEITUNG (GB)	MANUAL DE MANTENIMIENTO (GB)	H01	6
8A00B2859	TUBO	PIPE	TUYAU	LEITUNG	TUBO	J03	26
8AA090279	CANNOTTO DI STERZO	STEERING TUBE	COLONNE DE DIRECTION	LENKROHR	TUBO DE LA DIRECCION	B03	8
8AA090353	CERCHIO RUOTA POSTERIORE	REAR RIM	JANTE ROUE ARRIERE	HINTERRADFELGE	LLANTA RUEDA TRASERA	C01	1
8AB090983	CERCHIO RUOTA POSTERIORE	REAR RIM	JANTE ROUE ARRIERE	HINTERRADFELGE	LLANTA RUEDA TRASERA	C01	1
8B0036022	ROSETTA	WASHER	RONDELLE	UNTERLEGSCHIBE	ARANDELA	G11	12
8B0047859	GUARNIZIONE	GASKET	JOINT	DICHTUNG	EMPAQUE	A02	6
8B0057196	TAPPO	PLUG	BOUCHON	VERSCHLUSS	TAPON	G05	22
8B0067545	VITE M6X55	SCREW M6X55	VIS M6X55	SCHRAUBE M6X55	TORNILLO M6X55	G01	6
8B0069056	VITE M8X15	SCREW M8X15	VIS M8X15	SCHRAUBE M8X15	TORNILLO M8X15	D02	39
8B0070695	TAPPO	PLUG	BOUCHON	VERSCHLUSS	TAPON	A01	25
8B0081228	GUIDA VALVOLA	VALVE GUIDE	GUIDE DE SOUPAPE	VENTILFÜHRUNG	GUIA VALVULA	G04	3
8B0081315	SEMICUSCINETTO DI BIELLA (GIALLO)	BIG END HALF BEARING (YELLOW)	DEMI-COUSSINET DI BIELLE (JAUNE)	PLEUELLAGERHÄLFTE (GELB)	SEMICOJINETE DE BIELA (AMARILLO)	G02	5
8B0081316	SEMICUSCINETTO DI BANCO (GIALLO)	CRANKSHAFT HALF BEARING (YELLOW)	DEMI-COUSSINET DE PALIER (JAUNE)	KURBELWELLENLAGERHÄLFTE (GELB)	SEMICOJINETE PRINCIPAL (AMARILLO)	G01	17
8B0081317	SEMICUSCINETTO DI BANCO (GIALLO)	CRANKSHAFT HALF BEARING (YELLOW)	DEMI-COUSSINET DE PALIER (JAUNE)	KURBELWELLENLAGERHÄLFTE (GELB)	SEMICOJINETE PRINCIPAL (AMARILLO)	G01	16
8B0084182	PASTIGLIA REGOLAZIONE GIOCO (SP.1.70)	CLEARANCE ADJUSTING PAD (THICKNESS 1.70)	PASTILLE DE CALAGE (EP.1.70)	EINSTELLPLÄTTCHEN VENTILSPIEL (STÄRKE 1.70)	PASTILLA REGULACION JUEGO (SP.1.70)	G05	21
8B0084926	CORONA	GEAR	COURONNE	ZAHNKRANZ	CORONA	C01	28

INDICE CODICI / DENOMINAZIONI

 CODEX / DESIGNATION INDEX • INDEX CODES / DÉNOMINATIONS
 INHALTSVERZEICHNIS CODE • ÍNDICE CÓDIGOS / DENOMINACIONES

Code	Denominazione	Description	Désignation	Bezeichnung	Descripción	Table	N°
8B0089299	BUSSOLA	BUSH	BAGUE	HÜLSE	CASQUILLO	G16	8
8B0089516	CAPPUCCIO CONNETTORE DIAGNOSTICA	DIAGNOSTIC CONNECTOR CAP	CAPUCHON DU CONNECTEUR DIAGNOSTIC	DIAGNOSESTECKERKAPPE	CAPUCHON CONECTADOR DE LA DIAGNOSTICA	F03	12
8B0090369	FANALE POST. COMPLETO	TAIL LAMP ASSEMBLY	FEU ARRIERE COMPLET	RÜCKLICHT KOMPLETT	PILOTO TRASERO COMPLETO	F06	1
8B0090901	VITE M4X8	SCREW M4X8	VIS M4X8	SCHRAUBE M4X8	TORNILLO M4X8	E04	39
						F06	11
8B0091037	TUBO IN GOMMA	HOSE	DURIT	GUMMISCHLAUCH	TUBO DE GOMA	G13	18
						K02	20
8B0091687	FASCETTA A VITE	SCREW CLAMP	COLLIER A VIS	SCHRAUBENSHELLE	ABRAZADERA CON ROSCA	E04	9
8B0091696	PORTALAMPADA	LAMP HOLDER	DOUILLE D'AMPOULE	LAMPENHALTERUNG	PORTALAMPARA	F06	4
8B0091697	VITE M8X65	SCREW M8X65	VIS M8X65	SCHRAUBE M8X65	TORNILLO M8X65	G11	49
8B0092249	FASCETTA CLIC R	CLIC R CLAMP	COLLIER CLIC R	SHELLE CLIC R	ABRAZADERA CLIC R	G08	75
8B0092874	MANUALE OFFICINA MOTOTELAIO (F)	CHASSIS OVERHAUL HANDBOOK (F)	MANUEL D'ATELIER MECANIQUE GEN. (F)	WERKSTATTHANDBUCH MOTORRADRAHMEN (F)	MANUAL PARA TALLER VEHICULO (F)	H01	1
8B0096565	ROSETTA	WASHER	RONDELLE	UNTERLEGSCHEIBE	ARANDELA	G10	38
8B0098679	GUARNIZIONE TESTA (SP. 1.2)	HEAD GASKET (THICKNESS 1.2)	JOINT DE CULASSE (EP. 1.2)	ZYLINDERKOPFDICHTUNG (STÄRKE 1.2)	JUNTA CULATA (SP. 1.2)	G03	8
8B0099358	LIBRETTO USO E MANUTENZIONE (F)	USE AND MAINTENANCE HANDBOOK (F)	LIVRET UTILISATION ET ENTRETIEN (F)	BEDIENUNGSANLEITUNG (F)	MANUAL DE MANTENIMIENTO (F)	H01	6
8B0099360	MANUALE OFFICINA MOTOTELAIO (F)	CHASSIS OVERHAUL HANDBOOK (F)	MANUEL D'ATELIER MECANIQUE GEN. (F)	WERKSTATTHANDBUCH MOTORRADRAHMEN (F)	MANUAL PARA TALLERES VEHICULO (F)	H01	10
8B00A1234	ROSETTA	WASHER	RONDELLE	UNTERLEGSCHEIBE	ARANDELA	G10	38
8B00A1592	MANUALE OFFICINA MOTORE (F)	ENGINE OVERHAUL HANDBOOK (F)	MANUEL D'ATELIER MOTEUR (F)	WERKSTATTHANDBUCH MOTOR (F)	MANUAL PARA TALLER MOTOR (F)	H01	11
8B00A4020	LIBRETTO USO E MANUTENZIONE (F)	USE AND MAINTENANCE HANDBOOK (F)	LIVRET UTILISATION ET ENTRETIEN (F)	BEDIENUNGSANLEITUNG (F)	MANUAL DE MANTENIMIENTO (F)	H01	6
8BA084658	VITE AUTOFILETTANTE 5X25	TAPPING SCREW 5X25	VIS TARAUD 5X25	BLECHSCHRAUBE 5X25	TORNILLO AUTOENRROSCANTE 5X25	E03	7
8C0019590	RULLINO D5X15	NEEDLE D5X15	PION D5X15	STIFT Ø 5X15	RODILLO D5X15	G01	41
8C0036022	ROSETTA	WASHER	RONDELLE	UNTERLEGSCHEIBE	ARANDELA	G11	12
8C0037003	ROSETTA	WASHER	RONDELLE	UNTERLEGSCHEIBE	ARANDELA	F01	32
8C0069056	VITE M8X30	SCREW M8X30	VIS M8X30	SCHRAUBE M8X30	TORNILLO M8X30	J03	13
8C0084182	PASTIGLIA REGOLAZIONE GIOCO (SP.1.75)	CLEARANCE ADJUSTING PAD (THICKNESS 1.75)	PASTILLE DE CALAGE (EP.1.75)	EINSTELLPLÄTTCHEN VENTILSPIEL (STÄRKE 1.75)	PASTILLA REGULACION JUEGO (SP.1.75)	G05	21
8C0085071	VITE M6X16	SCREW M6X16	VIS M6X16	SCHRAUBE M6X16	TORNILLO M6X16	G05	9
8C0090424	VITE M5X12	SCREW M5X12	VIS M5X12	SCHRAUBE M5X12	TORNILLO M5X12	G08	50
						G13	3
8C0090426	VITE M8X16	SCREW M8X16	VIS M8X16	SCHRAUBE M8X16	TORNILLO M8X16	C02	6
8C0091697	VITE M8X70	SCREW M8X70	VIS M8X70	SCHRAUBE M8X70	TORNILLO M8X70	G15	3
8C0092249	FASCETTA CLIC R	CLIC R CLAMP	COLLIER CLIC R	SHELLE CLIC R	ABRAZADERA CLIC R	G08	65
8C0092256	FASCETTA CLIC R	CLIC R CLAMP	COLLIER CLIC R	SHELLE CLIC R	ABRAZADERA CLIC R	E04	30
8C0099270	CENTRALINA INIEZIONE (JPN)	INJECTION POWER UNIT (JPN)	BOITIER DE CONTROLE INIECTION (JPN)	EINSPRITZ-STEUERUNG (JPN)	CENTRALITA INJECCION (JPN)	F07	1
8C0099272	EPROM (JPN)	EPROM (JPN)	EPROM (JPN)	EPROM (JPN)	EPROM (JPN)	F07	2
8C0099274	FUSIBILE 5 A	FUSE 5 A	FUSIBLE 5 A	SICHERUNG 5 A	FUSIBLE 5 A	F07	14
8C0099358	LIBRETTO USO E MANUTENZIONE (D)	USE AND MAINTENANCE HANDBOOK (D)	LIVRET D'UTILISATION ET ENTRETIEN (D)	BEDIENUNGSANLEITUNG (D)	MANUAL DE MANTENIMIENTO (D)	H01	6
8C0099360	MANUALE OFFICINA MOTOTELAIO (D)	CHASSIS OVERHAUL HANDBOOK (D)	MANUEL D'ATELIER MECANIQUE GEN. (D)	WERKSTATTHANDBUCH MOTORRADRAHMEN (D)	MANUAL PARA TALLERES VEHICULO (D)	H01	10
8C00A1592	MANUALE OFFICINA MOTORE (D)	ENGINE OVERHAUL HANDBOOK (D)	MANUEL D'ATELIER MOTEUR (D)	WERKSTATTHANDBUCH MOTOR (D)	MANUAL PARA TALLERES MOTOR (D)	H01	11
8C00A4020	LIBRETTO USO E MANUTENZIONE (D)	USE AND MAINTENANCE HANDBOOK (D)	LIVRET D'UTILISATION ET ENTRETIEN (D)	BEDIENUNGSANLEITUNG (D)	MANUAL DE MANTENIMIENTO (D)	H01	6
8D0009408	ROSETTA	WASHER	RONDELLE	UNTERLEGSCHEIBE	ARANDELA	G06	11
8D0066531	VITE M5x14	SCREW M5x14	VIS M5x14	SCHRAUBE M5x14	TORNILLO M5x14	E04	2

INDICE CODICI / DENOMINAZIONI

CODEX / DESIGNATION INDEX • INDEX CODES / DÉNOMINATIONS

INHALTSVERZEICHNIS CODE • ÍNDICE CÓDIGOS / DENOMINACIONES

Code	Denominazione	Description	Désignation	Bezeichnung	Descripción	Table	N°
8D0067997	VITE M5X8	SCREW M5X8	VIS M5X8	SCHRAUBE M5X8	TORNILLO M5X8	F01	9
						F07	8
						G04	23
						G11	45
8D0081569	ROSETTA	WASHER	RONDELLE	UNTERLEGSCHIEBE	ARANDELA	G10	13
8D0084182	PASTIGLIA REGOLAZIONE GIOCO (SP.1.80)	CLEARANCE ADJUSTING PAD (THICKNESS 1.80)	PASTILLE DE CALAGE (EP.1.80)	EINSTELLPLÄTTCHEN VENTILSPIEL (STÄRKE 1.80)	PASTILLA REGULACION JUEGO (SP.1.80)	G05	21
8D0090424	VITE M5X14	SCREW M5X14	VIS M5X14	SCHRAUBE M5X14	TORNILLO M5X14	A01	32
						F07	5
8D0090425	VITE M6X14	SCREW M6X14	VIS M6X14	SCHRAUBE M6X14	TORNILLO M6X14	E01	7
8D0099270	CENTRALINA INIEZIONE	INJECTION POWER UNIT	BOITIER DE CONTROLE INIECTION	EINSPRITZ-STEUERUNG	CENTRALITA INJECCION	F07	1
8D0099272	EPROM	EPROM	EPROM	EPROM	EPROM	F07	2
8D0099274	FUSIBILE 7,5 A	FUSE 7,5 A	FUSIBLE 7,5 A	SICHERUNG 7,5 A	FUSIBLE 7,5 A	F07	16
8D0099358	LIBRETTO USO E MANUTENZIONE (E)	USE AND MAINTENANCE HANDBOOK (E)	LIVRET D'UTILISATION ET ENTRETIEN (E)	BEDIENUNGSANLEITUNG (E)	MANUAL DE MANTENIMIENTO (E)	H01	6
8D0099360	MANUALE OFFICINA MOTOTELAIO (E)	CHASSIS OVERHAUL HANDBOOK (E)	MANUEL D'ATELIER MECANIQUE GEN. (E)	WERKSTATTHANDBUCH MOTORRADRAHMEN (E)	MANUAL PARA TALLERES VEHICULO (E)	H01	10
8D00A1592	MANUALE OFFICINA MOTORE (E)	ENGINE OVERHAUL HANDBOOK (E)	MANUEL D'ATELIER MOTEUR (E)	WERKSTATTHANDBUCH MOTOR (E)	MANUAL PARA TALLERES MOTOR (E)	H01	11
8D00A4020	LIBRETTO USO E MANUTENZIONE (E)	USE AND MAINTENANCE HANDBOOK (E)	LIVRET D'UTILISATION ET ENTRETIEN (E)	BEDIENUNGSANLEITUNG (E)	MANUAL DE MANTENIMIENTO (E)	H01	6
8DA084658	VITE AUTOFILETTANTE 5X35	TAPPING SCREW 5X35	VIS TARAUD 5X35	BLECHSCHRAUBE 5X35	TORNILLO AUTOENROSCANTE 5X35	E03	8
8E0067997	VITE M5X10	SCREW M5X10	VIS M5X10	SCHRAUBE M5X10	TORNILLO M5X10	G13	11
						K02	4
8E0084182	PASTIGLIA REGOLAZIONE GIOCO (SP.1.85)	CLEARANCE ADJUSTING PAD (THICKNESS 1.85)	PASTILLE DE CALAGE (EP.1.85)	EINSTELLPLÄTTCHEN VENTILSPIEL (STÄRKE 1.85)	PASTILLA DE REGULACION JUEGO (SP.1.85)	G05	21
8E0087431	TUBO BENZINA	FUEL PIPE	CANALISATION ESSENCE	BENZINLEITUNG	TUBO GASOLINA	G12	16
8E0090425	VITE M6X16	SCREW M6X16	VIS M6X16	SCHRAUBE M6X16	TORNILLO M6X16	B03	6
8E0090426	VITE M8 X 20	SCREW M8 X 20	VIS M8 X 20	SCHRAUBE M8 X 20	TORNILLO M8 X 20	C01	26
8E0092249	FASCETTA CLIC R	CLIC R CLAMP	COLLIER CLIC R	SHELLE CLIC R	ABRAZADERA CLIC R	G08	59
8E0099270	CENTRALINA INIEZIONE (F)	INJECTION POWER UNIT (F)	BOITIER DE CONTROLE INIECTION (F)	EINSPRITZ-STEUERUNG (F)	CENTRALITA INJECCION (F)	F07	1
8E0099272	EPROM (F)	EPROM (F)	EPROM (F)	EPROM (F)	EPROM (F)	F07	2
8F0084182	PASTIGLIA REGOLAZIONE GIOCO (SP.1.90)	CLEARANCE ADJUSTING PAD (THICKNESS 1.90)	PASTILLE DE CALAGE (EP.1.90)	EINSTELLPLÄTTCHEN VENTILSPIEL (STÄRKE 1.90)	PASTILLA REGULACION JUEGO (SP.1.90)	G05	21
8F0090426	VITE M8x22	SCREW M8x22	VIS M8x22	SCHRAUBE M8x22	TORNILLO M8x22	A01	20
						D01	14
						D02	14
						D02	24
8F0092249	FASCETTA CLIC R	CLIC R CLAMP	COLLIER CLIC R	SHELLE CLIC R	ABRAZADERA CLIC R	G08	71
						G08	73
8F0099274	FUSIBILE 15 A	FUSE 15 A	FUSIBLE 15 A	SICHERUNG 15 A	FUSIBLE 15 A	F07	15
8G0004551	ROSETTA	WASHER	RONDELLE	UNTERLEGSCHIEBE	ARANDELA	G11	34
8G0048590	ROSETTA	WASHER	RONDELLE	UNTERLEGSCHIEBE	ARANDELA	G10	13
8G0070266	TUBO SERBATOIO/ POMPA FRENO	FUEL TANK/BRAKE PUMP PIPE	CANALISATION RESERVOIR/ MAITRE-CYLINDRE	LEITUNG BREMSFLÜSSIGKEITS- BEHÄLTER/ BREMSPUMPE	TUBO TANQUE/ BOMBA FRENO	D02	22
8G0084182	PASTIGLIA REGOLAZIONE GIOCO (SP.1.95)	CLEARANCE ADJUSTING PAD (THICKNESS 1.95)	PASTILLE DE CALAGE (EP.1.95)	EINSTELLPLÄTTCHEN VENTILSPIEL (STÄRKE 1.95)	PASTILLA REGULACION JUEGO (SP.1.95)	G05	21
8G0090425	VITE M6X20	SCREW M6X20	VIS M6X20	SCHRAUBE M6X20	TORNILLO M6X20	B02	4
						D01	19
						D01	20
						D02	19
						E03	9
						G16	21

INDICE CODICI / DENOMINAZIONI

 CODEX / DESIGNATION INDEX • INDEX CODES / DÉNOMINATIONS
 INHALTSVERZEICHNIS CODE • ÍNDICE CÓDIGOS / DENOMINACIONES

Code	Denominazione	Description	Désignation	Bezeichnung	Descripción	Table	N°
8G0090426	VITE M8x25	SCREW M8x25	VIS M8x25	SCHRAUBE M8x25	TORNILLO M8x25	A02	30
						B03	13
						D01	13
						D02	13
8G0092249	FASCETTA CLIC R	CLIC R CLAMP	COLLIER CLIC R	SCHELLE CLIC R	ABRAZADERA CLIC R	G08	55
						G08	66
8G0099270	CENTRALINA INIEZIONE (JPN)	INJECTION POWER UNIT (JPN)	BOITIER DE CONTROLE INIECTION (JPN)	EINSPRITZ-STEUERUNG (JPN)	CENTRALITA INJECCION (JPN)	F07	1
8G0099272	EPROM (JPN)	EPROM (JPN)	EPROM (JPN)	EPROM (JPN)	EPROM (JPN)	F07	2
8H0067545	VITE M6X12	SCREW M6X12	VIS M6X12	SCHRAUBE M6X12	TORNILLO M6X12	A02	15
						F01	12
						G16	19
8H0082751	VITE M10X26	SCREW M10X26	VIS M10X26	SCHRAUBE M10X26	TORNILLO M10X26	C02	17
8H0084182	PASTIGLIA REGOLAZIONE GIOCO (SP.2.00)	CLEARANCE ADJUSTING PAD (THICKNESS 2.00)	PASTILLE DE CALAGE (EP.2.00)	EINSTELLPLÄTTCHEN VENTILSPIEL (STÄRKE 2.00)	PASTILLA REGULACION JUEGO (SP.2.00)	G05	21
8H0087431	TUBO BENZINA	FUEL PIPE	CANALISATION ESSENCE	BENZINLEITUNG	TUBO GASOLINA	G12	17
8H0090424	VITE M5X22	SCREW M5X22	VIS M5X22	SCHRAUBE M5X22	TORNILLO M5X22	F03	5
8H0090425	VITE M6X22	SCREW M6X22	VIS M6X22	SCHRAUBE M6X22	TORNILLO M6X22	B03	7
						D03	4
8J0084182	PASTIGLIA REGOLAZIONE GIOCO (SP.2.05)	CLEARANCE ADJUSTING PAD (THICKNESS 2.05)	PASTILLE DE CALAGE (EP.2.05)	EINSTELLPLÄTTCHEN VENTILSPIEL (STÄRKE 2.05)	PASTILLA REGULACION JUEGO (SP.2.05)	G05	21
8J0090425	VITE M6X25	SCREW M6X25	VIS M6X25	SCHRAUBE M6X25	TORNILLO M6X25	D03	15
						D04	5
						F06	9
8J0090426	VITE M8X30	SCREW M8X30	VIS M8X30	SCHRAUBE M8X30	TORNILLO M8X30	A02	3
						B03	16
8J0099270	CENTRALINA INIEZIONE (JPN)	INJECTION POWER UNIT (JPN)	BOITIER DE CONTROLE INIECTION (JPN)	EINSPRITZ-STEUERUNG (JPN)	CENTRALITA INJECCION (JPN)	F07	1
8J0099272	EPROM (JPN)	EPROM (JPN)	EPROM (JPN)	EPROM (JPN)	EPROM (JPN)	F07	2
8K0084182	PASTIGLIA REGOLAZIONE GIOCO (SP.2.10)	CLEARANCE ADJUSTING PAD (THICKNESS 2.10)	PASTILLE DE CALAGE (EP.2.10)	EINSTELLPLÄTTCHEN VENTILSPIEL (STÄRKE 2.10)	PASTILLA REGULACION JUEGO (SP.2.10)	G05	21
8L0082751	VITE M10X31	SCREW M10X31	VIS M10X31	SCHRAUBE M10X31	TORNILLO M10X31	B01	22
						C02	16
8L0084182	PASTIGLIA REGOLAZIONE GIOCO (SP.2.15)	CLEARANCE ADJUSTING PAD (THICKNESS 2.15)	PASTILLE DE CALAGE (EP.2.15)	EINSTELLPLÄTTCHEN VENTILSPIEL (STÄRKE 2.15)	PASTILLA REGULACION JUEGO (SP.2.15)	G05	21
8L0090425	VITE M6X30	SCREW M6X30	VIS M6X30	SCHRAUBE M6X30	TORNILLO M6X30	G16	7
8L0092249	FASCETTA CLIC R	CLIC R CLAMP	COLLIER CLIC R	SCHELLE CLIC R	ABRAZADERA CLIC R	G08	73
8M0066179	TUBO IN GOMMA	HOSE	DURIT	GUMMISCHLAUCH	TUBO DE GOMA	G08	40
8M0084182	PASTIGLIA REGOLAZIONE GIOCO (SP.2.20)	CLEARANCE ADJUSTING PAD (THICKNESS 2.20)	PASTILLE DE CALAGE (EP.2.20)	EINSTELLPLÄTTCHEN VENTILSPIEL (STÄRKE 2.20)	PASTILLA REGULACION JUEGO (SP.2.20)	G05	21
8M0088581	CENTRALINA INIEZIONE (F)	INJECTION POWER UNIT (F)	BOITIER DE CONTROLE INJECTION (F)	EINSPRITZ-STEUERUNG (F)	CENTRALITA INJECCION (F)	F06	13
8M0090425	VITE M6X35	SCREW M6X35	VIS M6X35	SCHRAUBE M6X35	TORNILLO M6X35	E01	5
						E04	27
						F01	20
8M0092249	FASCETTA CLIC R	CLIC R CLAMP	COLLIER CLIC R	SCHELLE CLIC R	ABRAZADERA CLIC R	G12	14
8N0084182	PASTIGLIA REGOLAZIONE GIOCO (SP.2.25)	CLEARANCE ADJUSTING PAD (THICKNESS 2.25)	PASTILLE DE CALAGE (EP.2.25)	EINSTELLPLÄTTCHEN VENTILSPIEL (STÄRKE 2.25)	PASTILLA REGULACION JUEGO (SP.2.25)	G05	21
8P0082751	VITE M10X45	SCREW M10X45	VIS M10X45	SCHRAUBE M10X45	TORNILLO M10X45	B02	7
8P0084182	PASTIGLIA REGOLAZIONE GIOCO (SP.2.30)	CLEARANCE ADJUSTING PAD (THICKNESS 2.30)	PASTILLE DE CALAGE (EP.2.30)	EINSTELLPLÄTTCHEN VENTILSPIEL (STÄRKE 2.30)	PASTILLA REGULACION JUEGO (SP.2.30)	G05	21
8PA067545	VITE M6X22	SCREW M6X22	VIS M6X22	SCHRAUBE M6X22	TORNILLO M6X22	G13	20
8Q0092249	FASCETTA CLIC R	CLIC R CLAMP	COLLIER CLIC R	SCHELLE CLIC R	ABRAZADERA CLIC R	G08	61
8R0082751	VITE M10X50	SCREW M10X50	VIS M10X50	SCHRAUBE M10X50	TORNILLO M10X50	B02	19

INDICE CODICI / DENOMINAZIONI

 CODEX / DESIGNATION INDEX • INDEX CODES / DÉNOMINATIONS
 INHALTSVERZEICHNIS CODE • ÍNDICE CÓDIGOS / DENOMINACIONES

Code	Denominazione	Description	Désignation	Bezeichnung	Descripción	Table	N°
8R0084182	PASTIGLIA REGOLAZIONE GIOCO (SP.2.35)	CLEARANCE ADJUSTING PAD (THICKNESS 2.35)	PASTILLE DE CALAGE (EP.2.35)	EINSTELLPLÄTTCHEN VENTILSPIEL (STÄRKE 2.35)	PASTILLA REGULACION JUEGO (SP.2.35)	G05	21
8S0082751	VITE M10X55	SCREW M10X55	VIS M10X55	SCHRAUBE M10X55	TORNILLO M10X55	B02	18
8S0084182	PASTIGLIA REGOLAZIONE GIOCO (SP.2.40)	CLEARANCE ADJUSTING PAD (THICKNESS 2.40)	PASTILLE DE CALAGE (EP.2.40)	EINSTELLPLÄTTCHEN VENTILSPIEL (STÄRKE 2.40)	PASTILLA REGULACION JUEGO (SP.2.40)	G05	21
8S0090425	VITE M6X55	SCREW M6X55	VIS M6X55	SCHRAUBE M6X55	TORNILLO M6X55	F01	3
8S0092249	FASCETTA CLIC R	CLIC R CLAMP	COLLIER CLIC R	SHELLE CLIC R	ABRAZADERA CLIC R	G12	15
8SA067545	VITE M6X8	SCREW M6X8	VIS M6X8	SCHRAUBE M6X8	TORNILLO M6X8	F03	3
						F05	6
						F05	7
8T0084182	PASTIGLIA REGOLAZIONE GIOCO (SP.2.45)	CLEARANCE ADJUSTING PAD (THICKNESS 2.45)	PASTILLE DE CALAGE (EP.2.45)	EINSTELLPLÄTTCHEN VENTILSPIEL (STÄRKE 2.45)	PASTILLA REGULACION JUEGO (SP.2.45)	G05	21
8U0084182	PASTIGLIA REGOLAZIONE GIOCO (SP.2.50)	CLEARANCE ADJUSTING PAD (THICKNESS 2.50)	PASTILLE DE CALAGE (EP.2.50)	EINSTELLPLÄTTCHEN VENTILSPIEL (STÄRKE 2.50)	PASTILLA REGULACION JUEGO (SP.2.50)	G05	21
8U0092249	FASCETTA CLIC R	CLIC R CLAMP	COLLIER CLIC R	SHELLE CLIC R	ABRAZADERA CLIC R	G08	54
8V0067545	VITE M6X135	SCREW M6X135	VIS M6X135	SCHRAUBE M6X135	TORNILLO M6X135	G01	9
8V0084182	PASTIGLIA REGOLAZIONE GIOCO (SP.2.55)	CLEARANCE ADJUSTING PAD (THICKNESS 2.55)	PASTILLE DE CALAGE (EP.2.55)	EINSTELLPLÄTTCHEN VENTILSPIEL (STÄRKE 2.55)	PASTILLA REGULACION JUEGO (SP.2.55)	G05	21
8V0092249	FASCETTA CLIC R	CLIC R CLAMP	COLLIER CLIC R	SHELLE CLIC R	ABRAZADERA CLIC R	G08	58
8W0084182	PASTIGLIA REGOLAZIONE GIOCO (SP.2.60)	CLEARANCE ADJUSTING PAD (THICKNESS 2.60)	PASTILLE DE CALAGE (EP.2.60)	EINSTELLPLÄTTCHEN VENTILSPIEL (STÄRKE 2.60)	PASTILLA REGULACION JUEGO (SP.2.60)	G05	21



A series of horizontal dotted lines for writing, spanning the width of the page.



A series of horizontal dotted lines for writing, arranged in approximately 25 rows across the page.



MV AGUSTA S.p.A. - Servizio Assistenza Tecnica
Via Giovanni Macchi, 144 - 21100 Varese (VA) ITALY
Tel. (Italia) 800.36.44.06 - (estero) ++39 0332 254.712
Fax ++39 0332 329.379 - sito web "www.mvagusta.it"
Part. N. 800099359 Edizione N° 6